

# YAMAHA PX-3

*Natural Sound Linear Tracking Quartz Locked Stereo Turntable*  
*Optimum Mass, Minimum Resonance, Symmetrical Straight Tonearm*  
*Direct Drive, Coreless, Hall Element Motor*  
*Full Cartridge Interchangeability*  
*Light-Touch LSI Logic Controlled Automatic Operation*  
*High-Density, Feedback Resistant BMC Base*



# Linear Tracking Comes Into Its Own

That a linear tracking tonearm is the only way to achieve ideal disc reproduction has long been an accepted fact. Since records are originally produced or "mastered" using a linear cutting head, a linear playback system is obviously a necessity in achieving truly accurate reproduction. Several linear tracking turntables have appeared on the market in the past few years, some of which boast very fancy design and features. They didn't impress serious audiophiles, however, who stayed with traditional offset tonearm designs. Why? Because the new models failed to live up to the linear tracking ideal. They just weren't backed up by the advanced technology necessary to precisely recreate the movement of the recording lathe's cutting head. Yamaha's remarkable PX-2 was the first turntable to actually break the linear tracking barrier with stunning reproduction performance and outstanding reliability. Now Yamaha offers the PX-3 linear tracking turntable with essentially the same superior reproduction as the PX-2 as well as an unbeatable cost/performance ratio. A product of Yamaha's vast technological know-how and commitment to producing the very finest audio components, the PX-3 takes full advantage of the linear tracking design to deliver truly natural music reproduction. One measure of the PX-3's sophistication is that its tonearm has been critically designed to let you use virtually any cartridge (MC or MM) while maintaining ideal mass and minimum resonance characteristics. In fact, impressive sophistication extends to all aspects of the PX-3: the tonearm, motor, servo system, fully automatic operation, base, even the exterior design. Your first look will tell you, repeated listening will convince you: the PX-3 delivers everything other turntables have only promised.

## OPERATION AND PERFORMANCE THAT LEAVE NOTHING TO BE DESIRED

### THE AUDIBLE ADVANTAGES OF YAMAHA'S LINEAR TRACKING SYSTEM

The linear tracking design offers several distinct advantages, and Yamaha's superior system ensures that you enjoy their full benefits. Most important are the elimination of tracking error and inside force, as explained below.

#### Tracking Error Virtually Eliminated

When a record is mastered, the cutting stylus remains at precisely the same angle in relation to the disc from the outer to inner groove. When this same disc is played back with a conventional offset tonearm, however, the angle between the stylus and groove varies continuously as the arm swings out across the record. This variation from the correct angle is known as tracking error, and is one of the primary causes of harmonic distortion in disc reproduction. Despite all efforts to minimize this problem, even the best offset arms will have a tracking error which varies from  $-1$  to  $+2.5^\circ$ .

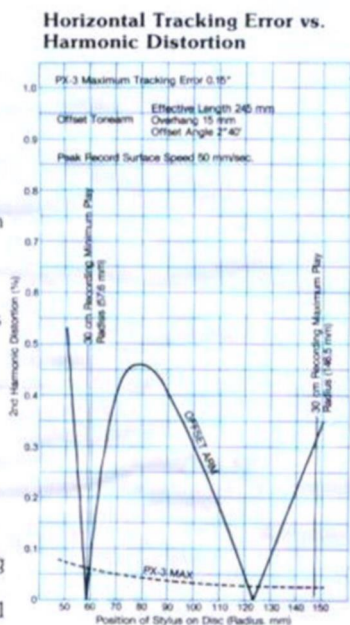

The PX-3's linear tracking system, however, ensures no more than  $0.15^\circ$  tracking error at any point across the record, so harmonic distortion is virtually eliminated.

#### Zero Inside Force

Conventional tonearms also suffer from inside force, which pulls the stylus and tonearm toward the center of the record. This results in uneven tracking force, causing uneven wear on records and stylus, as well as intermodulation distortion. Although most offset arms have an "anti-skating control" to reduce the problem, they cannot eliminate it entirely. The PX-3 linear tracking tonearm, however, maintains the ideal relationship between arm support, stylus, and record surface movement

throughout the entire tracking path, so inside force cannot occur. This means greatly reduced intermodulation distortion, minimum crosstalk, precise left/right balance and exceptional stereo imaging. It all adds up to incomparable reproduction performance.

#### Sophisticated Engineering Makes it all Possible

All these advancements in disc reproduction quality are the result of Yamaha's sophisticated linear tracking mechanism. The tonearm is driven in its path across the record by a precision-engineered, high torque coreless motor coupled to the tonearm carriage via a pulley and idler system and a noise-damping belt. The motor itself is encased in neoprene rubber to minimize transmission of mechanical noise. And for further insurance against noise reaching the stylus, the tonearm carriage is precision-machined from a heavy metal alloy, and travels on accurately ground rollers and guide rails. Tonearm position is controlled by a

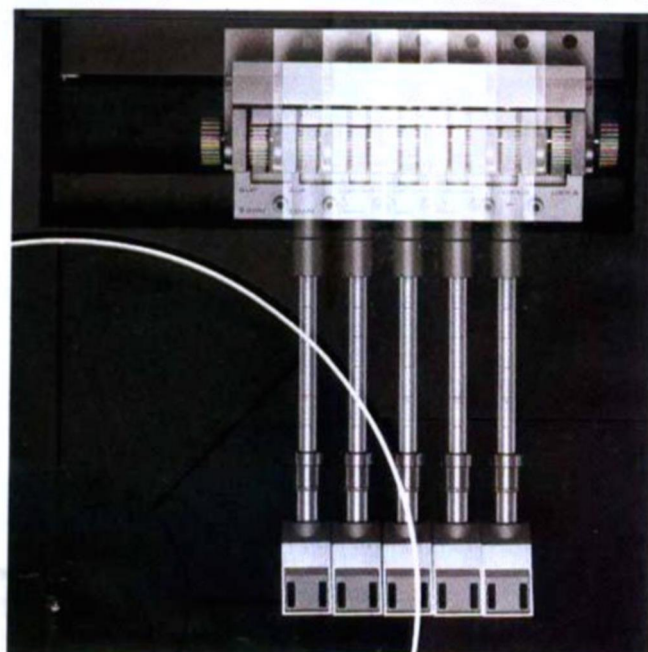

#### Tracking Error Sensor

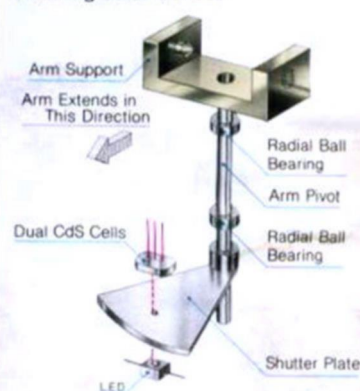

# Yamaha: Dedication to Musical Excellence

Today the world's largest manufacturer of musical instruments is also a leader in audio fidelity. For nearly a hundred years Yamaha craftsmen have been designing full, natural sound into our renowned pianos, organs, wind and string instruments—a rich musical tradition that makes us unique in the audio world. Part of the reason is our generations of musical sensitivity. But it's also due to our immense technological and production capabilities—built over decades of supplying fine musical instruments to the world.

## The Basics

Audio performance depends on a wide range of technologies. While Yamaha's computer-controlled circuit design and testing is second to none, our music instrument experience has given us expertise in many other crucial fields. The Yamaha factories which produce semiconductors for our renowned electronic music instruments are also important in the development of advanced semiconductors for many of our audio amplifiers. They are also responsible for our unique vapor-deposited beryllium speaker domes. Our experience with metallurgy for brass instruments and diecast piano frames is behind the special alloys used in our powerful speaker magnets and acoustically ideal turntable platters. And Yamaha wood-crafting skill is reflected in our speaker enclosures and component cabinetry.

All these

advanced technologies blend together in Yamaha audio components to provide you with perfectly balanced, natural sound reproduction, unexcelled reliability and the finest in convenience control features.

## In-House

Every crucial part of every Yamaha audio component is Yamaha made. That's how we set our own quality standards. And that's how we can afford to innovate every step of the way: When a part or material doesn't do justice to the music we simply develop one that does.

## The Payoff

When you have musicians and audio engineers speaking the same language the result is full natural sound fidelity, plus innovative features which translate directly into improved tonal quality or operating convenience. Yamaha's insistence on total musical performance, not just isolated specs, is behind a revolutionary new approach to audio component design.



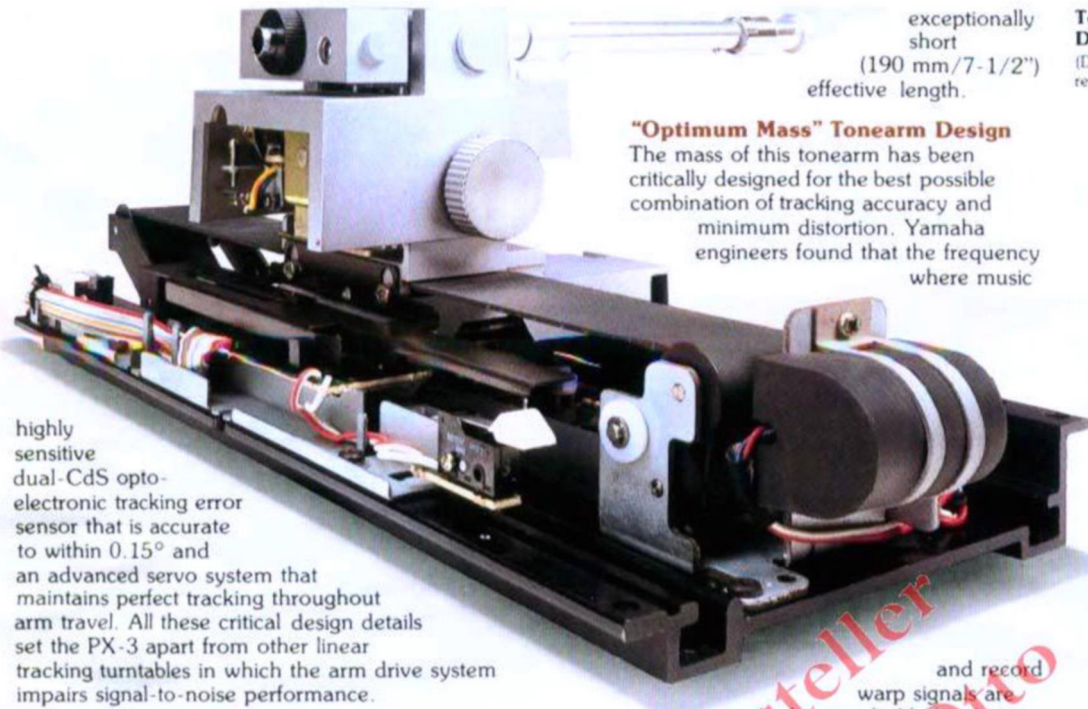

exceptionally short  
(190 mm / 7-1/2")  
effective length.

### "Optimum Mass" Tonearm Design

The mass of this tonearm has been critically designed for the best possible combination of tracking accuracy and minimum distortion. Yamaha engineers found that the frequency where music

### Tonearm Resonance & Intermodulation Distortion

(Dotted line = overall response. Solid line = single frequency response.  $f_0$  = tonearm resonant frequency,  $f_s$  = single frequency.)

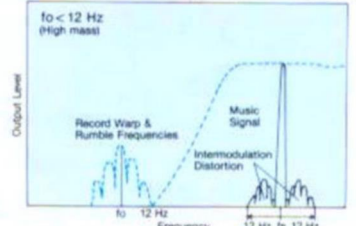

Tonearm resonance in recent warp & rumble range causes intermodulation distortion.

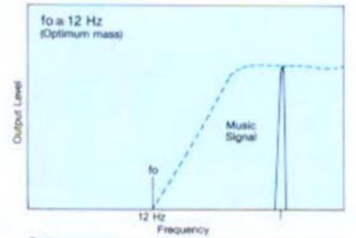

Optimum mass tonearm causes no intermodulation distortion.

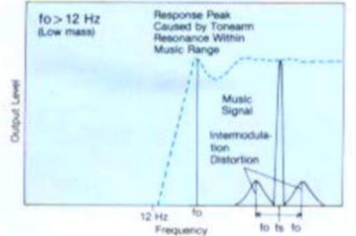

highly sensitive dual-CdS opto-electronic tracking error sensor that is accurate to within  $0.15^\circ$  and an advanced servo system that maintains perfect tracking throughout arm travel. All these critical design details set the PX-3 apart from other linear tracking turntables in which the arm drive system impairs signal-to-noise performance.

### THE YAMAHA STRAIGHT, PERFECTLY SYMMETRICAL TONEARM

#### Higher Stability for Minimum Distortion

The PX-3's straight tonearm is the result of in-depth research and extensive experimentation into every detail of tonearm design. It offers the audio enthusiast greatly improved disc reproduction performance in a number of important areas. The straight, perfectly symmetrical, tubular configuration is inherently more stable than conventional tonearm designs, and is highly resistant to resonance and oscillation. Many tonearms are particularly sensitive to "twist-mode" oscillation, or the tendency of a curved tonearm to twist about its axis causing intermodulation distortion. This sound-degrading oscillation is virtually eliminated in the Yamaha tonearm by the natural rigidity of the straight tubular design. To further reduce the possibility of this type of oscillation occurring, Yamaha engineers replaced the conventional round counter-weight with a large, rectangular type located as close as possible to the rear of the tonearm pivot. The relatively high mass of the weight effectively dampens most tonearm oscillation. In addition, the pivot span has been made much wider than normal for even greater stability. Other forms of resonance (bending mode) are minimized by the use of a double tonearm wall extending 30 mm (1-1/4") from the front of tonearm housing, and by the arm's

and record warp signals are both at negligible levels, i.e. where resonance has the least effect on reproduction quality, is about 12 Hz.

#### Spectral analysis graph of a typical direct-cut disc

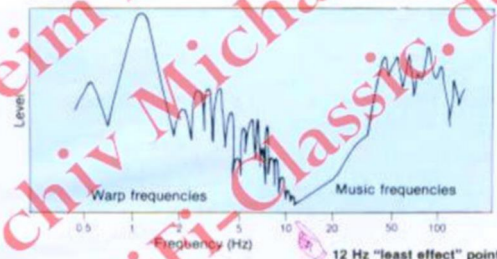

#### Resonant Frequency of Yamaha Straight Tonearm with Various Cartridges

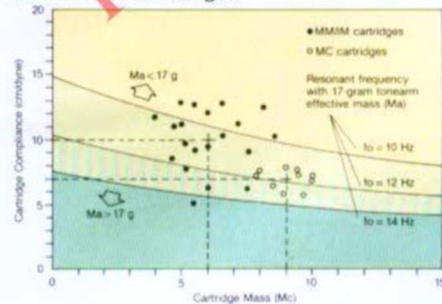

They then designed the tonearm so that in combination with the greatest possible percentage of compatible cartridges the arm's resonant frequency would fall within very close tolerance of the critical 12 Hz point. The result is that you can select just about any cartridge from the wide range available and still get the outstanding performance this unique tonearm is designed to provide.

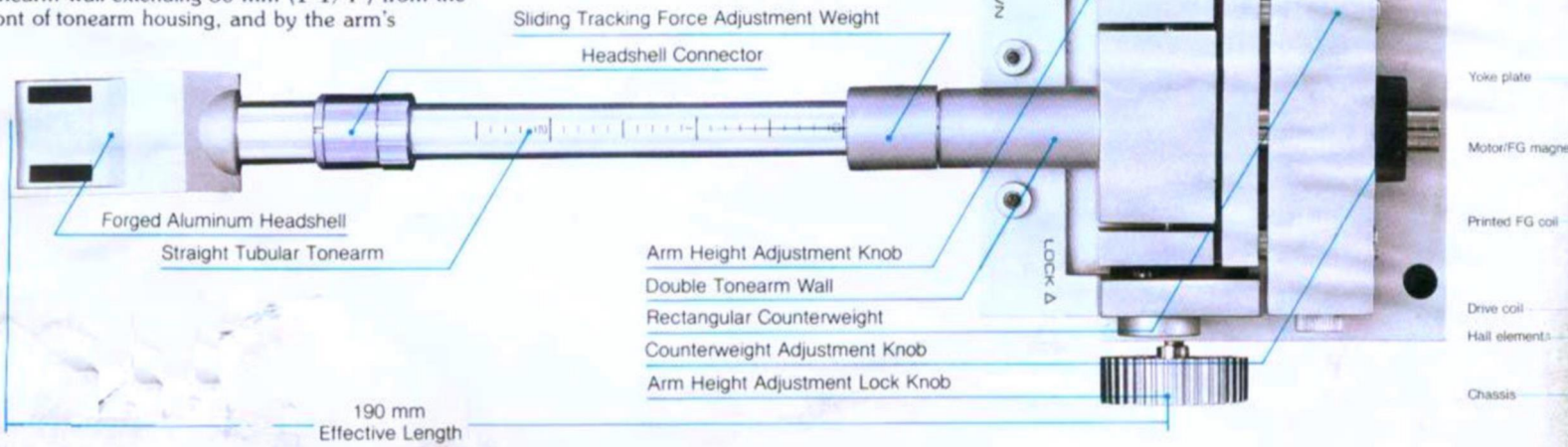
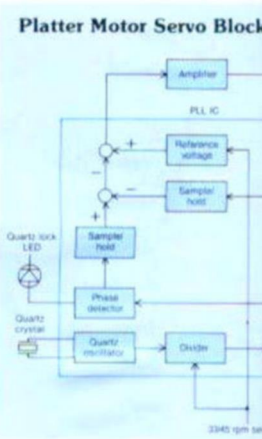

# PX-3

Natural Sound Linear Tracking Quartz Locked Stereo Turntable

A glance at the accompanying graph shows that almost all popular cartridges fall within the range acceptable for use with the PX-3. And note the MC cartridges—they are grouped closely around the optimum 12 Hz line. This means that your high performance MC cartridge will sound its best with the PX-3 tonearm—because Yamaha engineers planned it that way.

## Tonearm Height Adjustment

Complementing this wide range of cartridge compatibility is a tonearm height control. The tonearm can easily be adjusted for perfect horizontality with any size cartridge, an important factor in maintaining vertical tracking accuracy. No matter what cartridge you use, you're assured of obtaining the outstanding performance the tonearm was designed to provide.

## SUPERIOR MOTOR WITH QUARTZ LOCK PLL SERVO CONTROL

Since the PX-3 has such a superlative tonearm and linear tracking system, Yamaha engineers took great care to ensure that overall performance would not be degraded by the platter drive system. They installed an extensively-tested, high precision, coreless, slotless Hall-element motor to drive the platter directly. This top performance motor in combination with the heavy platter provides a high moment of inertia to eliminate high-frequency flutter, and ensures that transient load disturbances will have little or no effect on rotational speed. The speed of the motor is precisely controlled by a quartz lock PLL (phase-locked loop) servo system. Motor speed is constantly monitored via an FG (frequency generator) feedback system and compared with a reference fre-

quency derived from a perfectly accurate quartz crystal oscillator. If the speed of the motor varies, even slightly, the error is immediately detected by the phase comparator and the servo circuitry goes into action to restore proper platter speed. All this happens within a fraction of a second so platter speed remains constant even under varying load or temperature. And since the motor is a slotless,

## A PLEASURE TO OPERATE

### Advanced Automatic Control Features

The PX-3 incorporates a specially developed Yamaha logic LSI which provides extensive control convenience and flexibility. And all control buttons are located on the front panel outside the dust cover so all operations can be carried out with the dust cover lowered. Two Play/Disc Size selectors let you initiate automatic lead-in, cue and play with 17 or 30 cm (7" or 12") records. An opto-electronic disc access control sensor built into the tonearm carriage base positions the stylus precisely over the lead-in groove of the selected record. Speed selection (45 or 33-1/3 rpm) is done with a single button. When the tonearm reaches the record's lead-out groove and speeds up, a velocity sensor activates the mechanism which raises the arm and returns it to its original position. If the play button is accidentally depress-

ed when a record is not on the platter, pushing the cut or cueing buttons will ensure that the arm does not lower onto the platter. Most other linear tracking turntables do not have this feature—switching them off in time is your only hope of avoiding stylus damage.

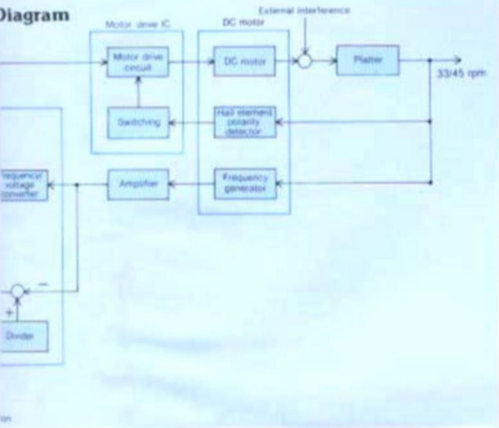
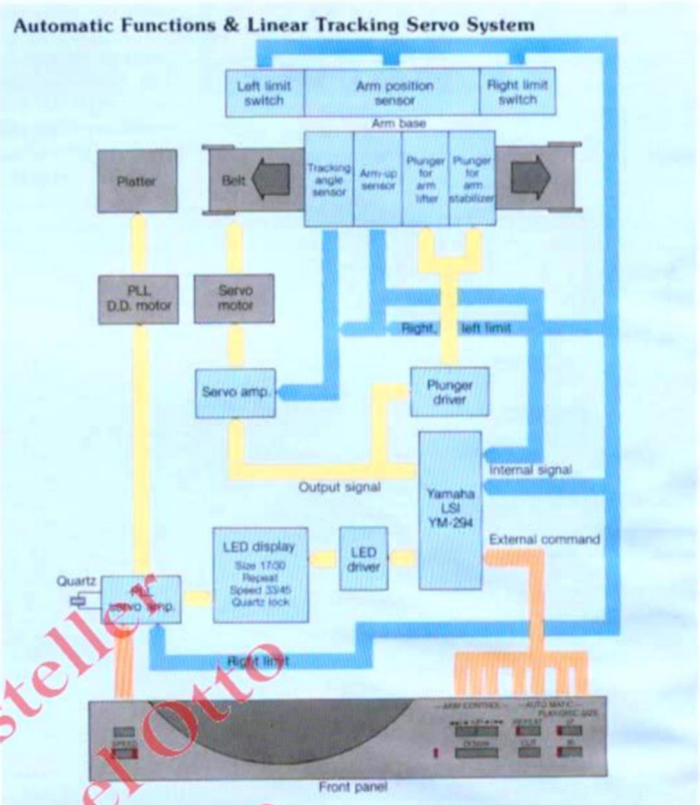

## Drive Motor Construction

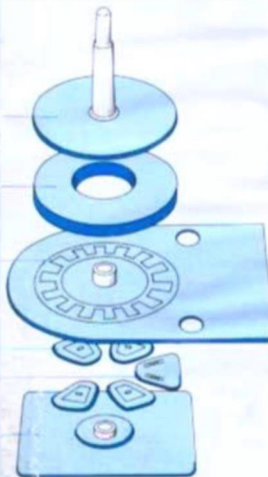

quency derived from a perfectly accurate quartz crystal oscillator. If the speed of the motor varies, even slightly, the error is immediately detected by the phase comparator and the servo circuitry goes into action to restore proper platter speed. All this happens within a fraction of a second so platter speed remains constant even under varying load or temperature. And since the motor is a slotless,

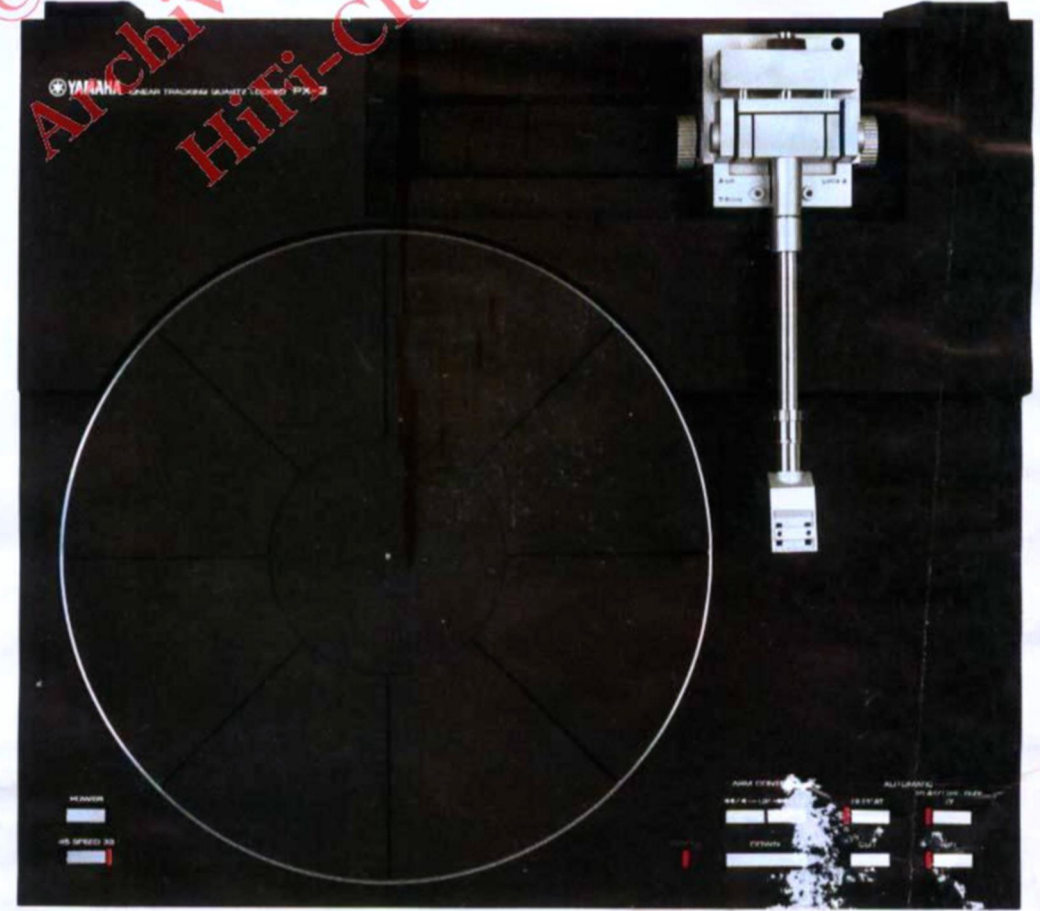

# PX-3

Natural Sound Linear Tracking Quartz Locked Stereo Turntable

## 2-Speed Tonearm Positioning

Tonearm cueing and lateral movement are controlled by three buttons. One cues the arm down onto the record, while the other two cause it to lift and move to the left or right. In addition you have the choice of two speeds: firmly pressing either the left or right button moves the arm rapidly in that direction, while a light touch causes it to travel slowly for accurate positioning. Other convenient functions are a repeat mode, which directly repositions the tonearm at the record's lead-in groove after the last track has been played, and a cut button for interrupting play and returning the arm to its rest. The tonearm is also automatically raised when the power is switched off, preventing possible stylus damage. For easy visual reference, LEDs indicate when each mode is in an operational state.

## THE FINEST QUALITY THROUGHOUT

### High Density BMC Base

Since any vibration in the turntable can be picked up and reproduced by the stylus, causing intermodulation distortion and degrading reproduction quality, the PX-3 uses a Yamaha-developed high density BMC (bulk-moulding compound) base that virtually eliminates the possibility of vibration occurring within the turntable itself. External vibrations (such as sound from speakers) are also prevented from being transmitted through the base to the stylus, which would cause annoying feedback.

And unique Yamaha insulator feet incorporating a dual spring/rubber damping system and height adjustment provide an extra measure of protection against outside disturbances.

### Forged Aluminum Headshell

Like the rest of the PX-3, the headshell is designed and constructed for optimum reproduction performance. It is forged of solid aluminum for high rigidity so no resonance can interfere with sound quality, and the cartridge is attached with two bolts and a solid aluminum crossbar rather than the conventional bolts and individual nuts. And since the headshell is electrically conductive, its hum rejection characteristics are ideal.



## Top Quality Cable with Gold-Plated Connectors

Even the PX-3 connector cables are special. They are high quality, low impedance types that ensure maximum signal transmission efficiency and accuracy. And the phono connectors are plated with gold so they cannot corrode and cause increased contact resistance.

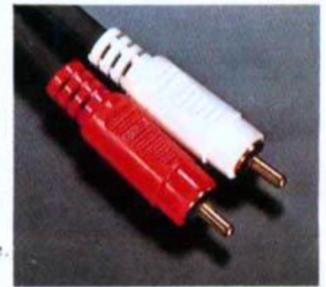

## Styled to Match Performance

The PX-3's overall performance is best described as sophisticated, and the same word applies to its styling. Sleek, clean, uncomplicated—all the design elegance you associate with a Yamaha component is embodied in the PX-3. The pleasure you derive from its sound can only be enhanced by its handsome appearance in your listening room.

## Other Features

- 1.1 kg, 4-mm thick acrylic dust cover with sloping front for accurate, easy visual monitoring of tonearm positioning.
- Accurate sliding tracking force adjustment weight.

## PX-3 SPECIFICATIONS

### TURNTABLE

Drive System	Quartz PLL/FG (Full Periphery Integration) Servo Direct Drive
Motor	4-Phase 8-Pole Coreless DC Hall-Effect Motor
Platter	Aluminum Diecast, 30 cm (12-1/2"), 1.6 kg (3 lbs. 8 oz.) Including Rubber Mat
Platter Moment of Inertia	210 kg cm <sup>2</sup> (Including Rubber Mat)
Speeds	33-1/3 and 45 rpm

### TONEARM

Type	Linear Tracking, Straight, Tubular
Drive System	Opto-Electronic Tracking Error Sensor and Coreless DC Servo Motor
Overall/Effective Length	236/190 cm (9-1/4"/7-1/2")
Tracking Force	Static Balance, Sliding Weight 0—2.5 g, 0.1 g increments
Suitable Cartridge Weight	5—11 g (10—16 g with Subweights)
Effective Mass	Tracking Force Proportional, 16.0—18.0 g
Tangential Tracking Error	± 0.15° maximum
Arm Lifter	Electronic, Oil Damped
Arm Height Adjustment	± 4 mm (± 1/6")
Headshell	Forged Aluminum EIA Type, 8.0 g, Gold-Plated Connectors
PU Cable	Low-Impedance Neglex 2496

Resistance	1 ohm, Connectors to Pin Plugs/Pin Plugs to Connectors
Capacitance	130 pF

### CONTROL FUNCTIONS

Automatic	Lead-In, Return, Repeat, Arm Up at Power Off
Size Selectors	17 cm (7"), 30 cm (12")
Manual	Arm Up, Arm Down, Cut, 2-Speed Arm Positioning

### CABINET

Base	High Density BMC Black Finish
Dust Cover	4 mm Acryl, 1.1 kg (2 lbs. 9 oz.) Removable, Free-Stop Hinges
Insulators	Spring/Rubber

### PERFORMANCE

Signal-to-Noise Ratio	77 dB (DIN B/IEC 98A, Weighted)
Wow and Flutter	0.015% WRMS (FG Direct Measurement)

### GENERAL

Power Supplies	Matched to supply voltage and frequency of each area
Power Consumption	27 W
Dimensions (W x H x D)	469 x 149 x 428 mm (18-1/2" x 5-7/8" x 16-7/8")
Weight	12 kg (26 lbs. 6 oz.)

Specifications subject to change without notice.

For details please contact:

SINCE 1887



# YAMAHA

NIPPON GAKKI CO., LTD. HAMAMATSU, JAPAN