

# YAMAHA PX-2

*Linear Tracking Quartz Locked Stereo Turntable, No-Contact Optical Tracking Error Sensor System, Tangent-Error-Free Linear Tracking System with 80-dB S/N, Minimum Resonance Optimum Mass Symmetrical Straight Tonearm, Tonearm Height Adjustment and Full Cartridge Interchangeability, 0.01% Wow & Flutter with Quartz PLL Servo and Coreless Hall Element Motor, Fully Automatic Operation and Electronic Front Panel Controls, Total Human Engineering in Base and Dust Cover Design, 2-Speed Tonearm Positioning Control, Heavy Feedback-Resistant Diecast Aluminum Base and Acrylic Dust Cover*

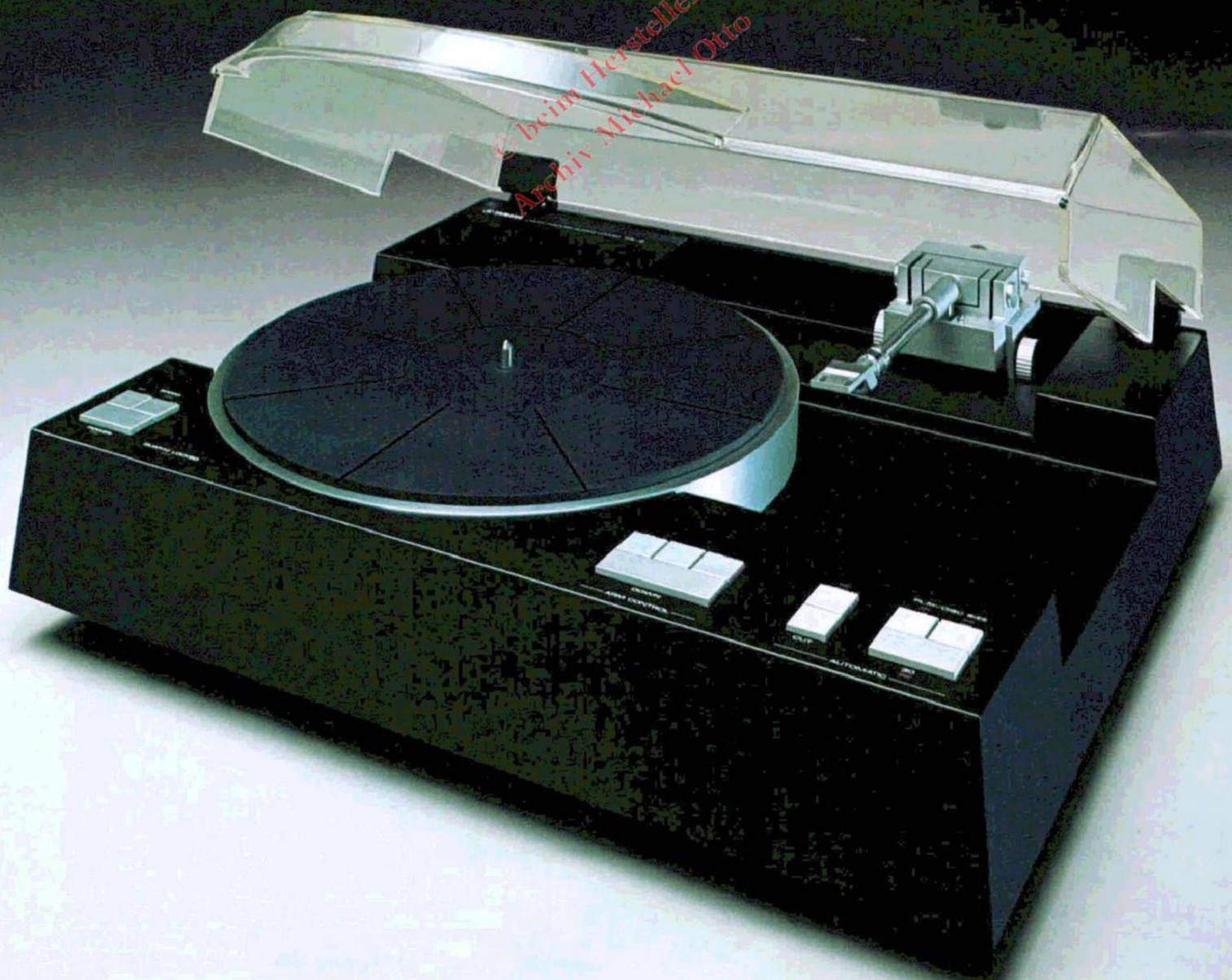

# Yamaha: Dedication to Musical Excellence

Today the world's largest manufacturer of musical instruments is also a leader in audio fidelity. For nearly a hundred years Yamaha craftsmen have been designing full, natural sound into our renowned pianos, organs, wind and string instruments—a rich musical tradition that makes us unique in the audio world. Part of the reason is our generations of musical sensitivity. But it's also due to our immense technological and production capabilities—built over decades of supplying fine musical instruments to the world.

## The Basics

Audio performance depends on a wide range of technologies. While Yamaha's computer-controlled circuit design and testing is second to none, our music instrument experience has given us expertise in many other crucial fields. The Yamaha factories which produce semiconductors for our renowned electronic music instruments are also important in the development of advanced semiconductors for many of our audio amplifiers. They are also responsible for our unique vapor-deposition beryllium speaker domes. Our experience with metallurgy for brass instruments and diecast piano frames is behind the special alloys used in our powerful speaker magnets and acoustically ideal turntable platters. And Yamaha woodcrafting skill is reflected in our speaker enclosures and component cabinetry.

## In-House

Every crucial part of every Yamaha audio component is Yamaha made. That's how we set our own quality standards. And that's how we can afford to innovate every step of the way: When a part or material doesn't do justice to the music we simply develop one that does.

## The Payoff

When you have musicians and audio engineers speaking the same language the result is full natural sound fidelity, plus innovative features which translate directly into improved tonal quality or operating convenience. Yamaha's insistence on total musical performance, not just isolated specs, is behind a revolutionary new approach to audio component design.

# PX-2: Realization of the Disc Reproduction Ideal

## Linear Tracking

The fact that a linear tracking tonearm is the ideal system for optimum disc reproduction performance has been known for a long time.

Virtually since the beginning of electronic phono reproduction. Since records are originally produced on a lathe with a linear cutting head, a linear tracking tonearm for playback is obviously the only way to achieve truly accurate reproduction.

Although several linear tracking turntables have appeared on the market in the past, serious audiophiles have stayed with the traditional offset tonearm designs.

The reason for this is simply that previous linear tracking systems did not provide the kind of performance they promised. It was just not technologically feasible to produce a linear tracking mechanism that could precisely recreate the movement of the recording lathe's cutting head.

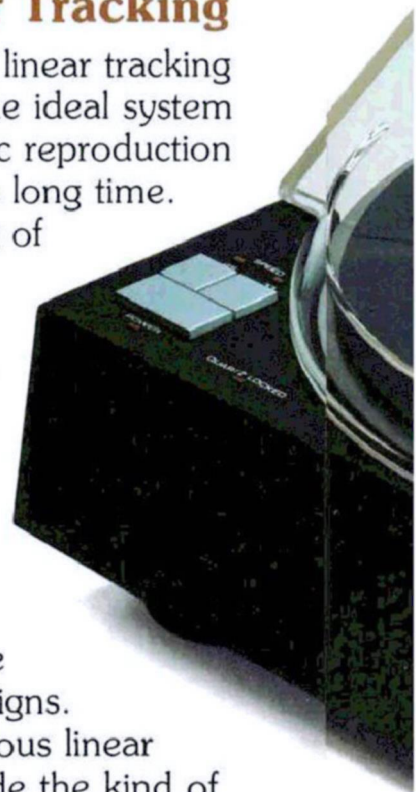

© bein-Hersteller  
Archiv-Michael Otto

# PX-2

Natural Sound Linear Tracking Turntable

## The Yamaha PX-2

At last, true linear tracking has arrived. Yamaha engineers pooled all their resources and experience to produce the finest turntable ever. The PX-2 Linear Tracking Turntable is the culmination of vast technological know-how, extensive research and development, and highly sophisticated design. The PX-2 offers more than just ultimate sound reproduction performance, however. It incorporates many unique features that make operation fast and convenient. And, above all, the PX-2 is extremely reliable and durable.

It will provide top performance for many years of the ultimate in high-fidelity listening.



# An Uncompromising Combination of Vast Technologies

## Linear Tracking Benefits

When a record is originally cut, the cutting head and stylus remain at precisely the same angle in relation to the disc from the extreme outer to the inner groove. When this same disc is played back with a conventional offset tonearm, however, the angle between the reproduction stylus and modulated groove varies continuously as the tonearm swings out across the record surface. This variation from the correct angle is known as "tracking error," and is one of the primary causes of harmonic distortion in disc reproduction. As the tracking error increases and decreases throughout an offset tonearm's curved tracking path, the harmonic distortion level increases and decreases accordingly. Despite all efforts to minimize tracking error, even the best offset tonearms can cover a tracking angle range as wide as  $-1$  to  $+2.5^\circ$ . The harmonic distortion that results at the extremes is too severe to be overlooked by the serious audiophile.

The PX-2's unique linear tracking system, however, ensures no more than  $0.15^\circ$  tracking error at any point across the record, so harmonic distortion is virtually eliminated.

Horizontal Tracking Error vs. Harmonic Distortion

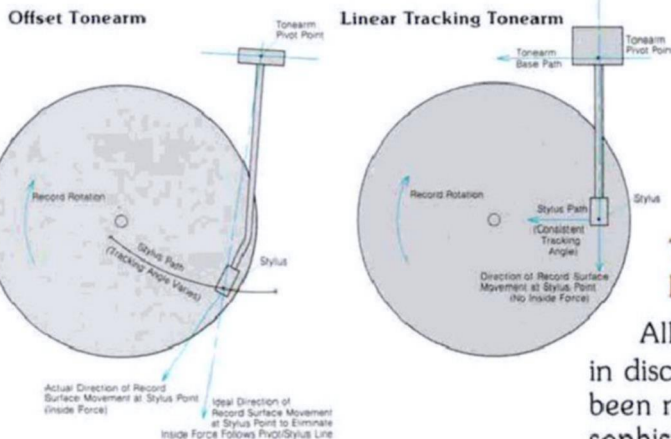
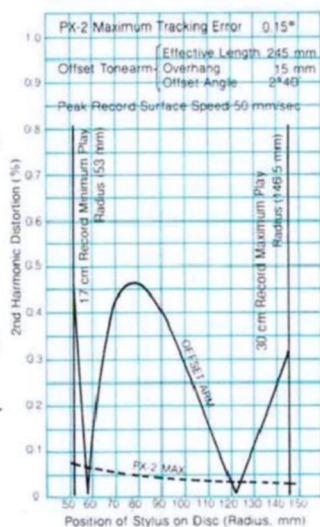

## Tonearm Cutaway Diagram

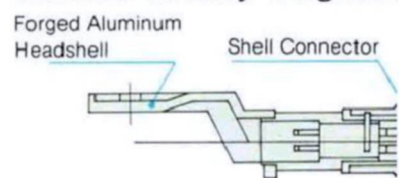

## The Technology Behind the Ideal

All these incredible advancements in disc reproduction quality have been made possible by a highly sophisticated linear tracking mechanism. The tonearm is driven in its path across the record

uneven wear on records and stylus, and intermodulation distortion. Also, since the stylus is constantly being pulled inward in relation to the cartridge, irregularities in reproduction linearity and increased crosstalk are common. Although almost all offset tonearms feature an "inside force canceller" or "anti-skating" control that reduces these problems to reasonable levels, these devices cannot eliminate inside force entirely. The PX-2 linear tracking tonearm, however, maintains the ideal relationship between arm support, stylus and record surface movement throughout its entire tracking path so inside force cannot occur.

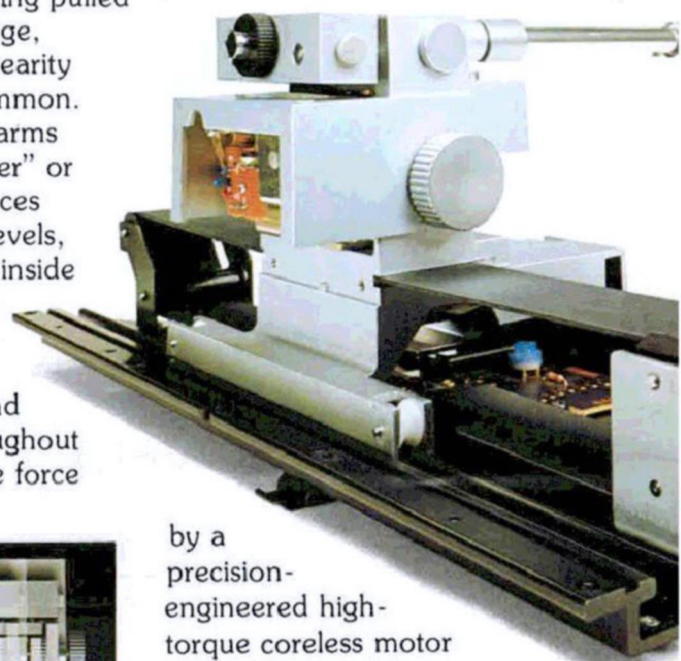

by a precision-engineered high-torque coreless motor coupled to the tonearm carriage via a gear and pulley system and a noise-damping belt. The motor itself is encased in neoprene and supported on a butyl base to minimize transmission of mechanical noise, while the belt, formed of specially selected materials, further dampens mechanical noise so it transmits only smooth power to the tonearm carriage. For absolute insurance against mechanical noise reaching the tonearm and stylus,

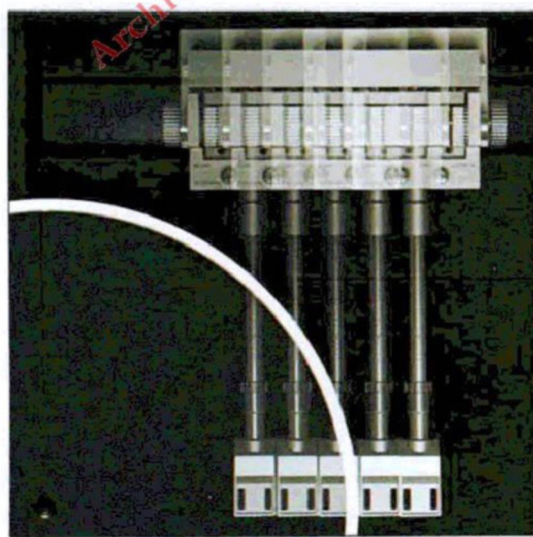

This means that, in addition to negligible tracking error and harmonic distortion, you get incomparable reproduction performance with dramatically reduced intermodulation distortion, minimum crosstalk, precise left/right balance and exceptional stereo imaging.

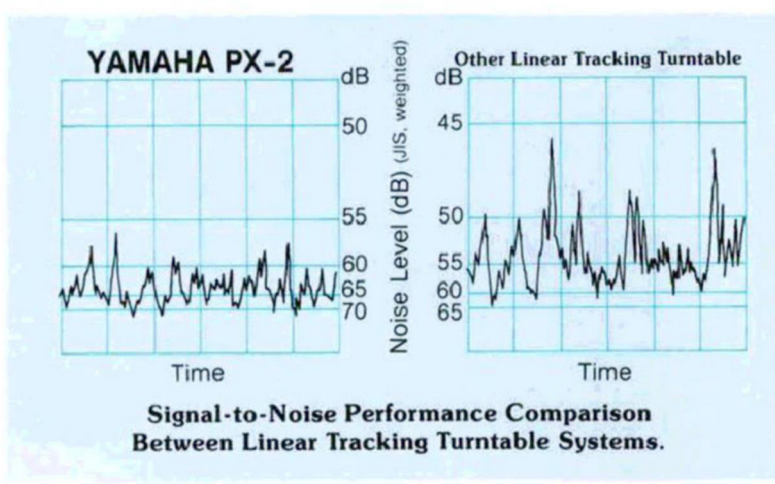

## Inside Force Eliminated

In conventional offset tonearms, many of the design features incorporated to reduce tracking error—including offset angle and overhang—combine with the tonearm's inherently curved tracking path to cause a phenomenon known as "inside force." That is, the direction of record surface movement at the point where the stylus rests falls along a different vector than would be obtained by drawing a line directly between the tonearm support or "pivot point" and the stylus, in effect "pulling" the stylus and tonearm toward the center of the record. This results in a number of reproduction problems including uneven tracking force that can cause

# Expertise, Human Engineering and Fine Craftsmanship

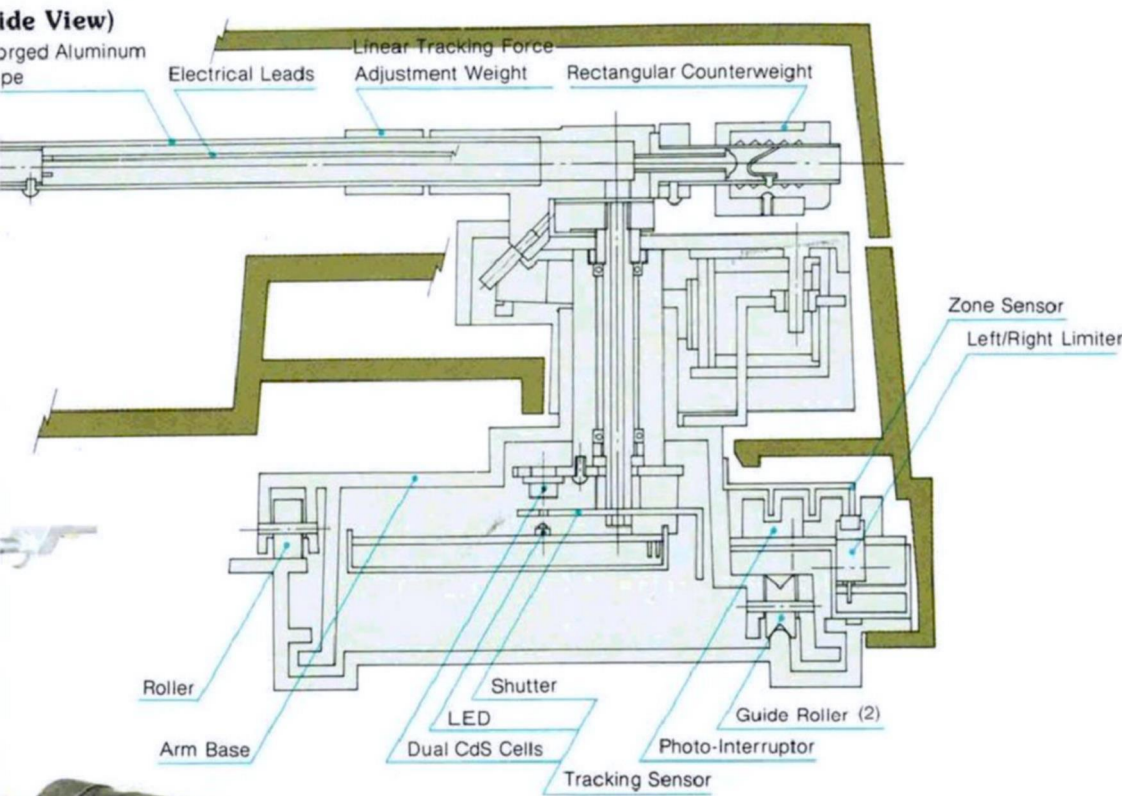

maximum tracking speed (3 times higher than standard lead out groove speed) to eliminate the possibility of damage to records or stylus when playing records with an unusually fast-moving lead-out or "tail" groove.

## Symmetrically Balanced Optimum Mass Tonearm

In addition to the exclusive performance benefits provided by the PX-2 linear tracking system, the tonearm itself offers several pleasant surprises. Since the tonearm is a perfectly symmetrical straight tubular design, "twist-mode" oscillation, or the tendency of a tonearm to twist about its axis causing intermodulation distortion, is virtually eliminated. And because of its exceptionally short effective length (190 mm), "bending-mode" oscillation is also vastly reduced.

Further, this unusually short, straight tonearm has much lower effective mass than conventional designs, permitting accurate vertical tracing even on warped records so tracing distortion is negligible. Yamaha engineers were also careful to make sure that the tonearm's resonant frequency would fall within very close

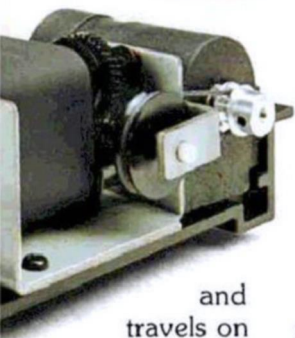

the tonearm carriage is precision-machined from a heavy metal alloy, Tracking Error Sensor

turntables in which the arm drive system impairs signal-to-noise performance. Tonearm position is controlled by a highly sensitive dual-CdS optoelectronic tracking error sensor that is accurate to within  $0.15^\circ$  and an advanced servo system that maintains perfect tracking throughout arm travel.

and travels on accurately ground rollers and guide rails. All these critical design details contribute to the PX-2's outstanding 80-dB

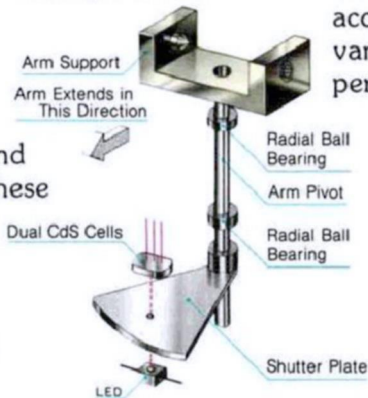

The servo system also features a specially designed "dead zone" that prevents backwards tonearm travel that can degrade sound quality with off-center records. As an added safety feature, the tonearm servo system is designed with a relatively high

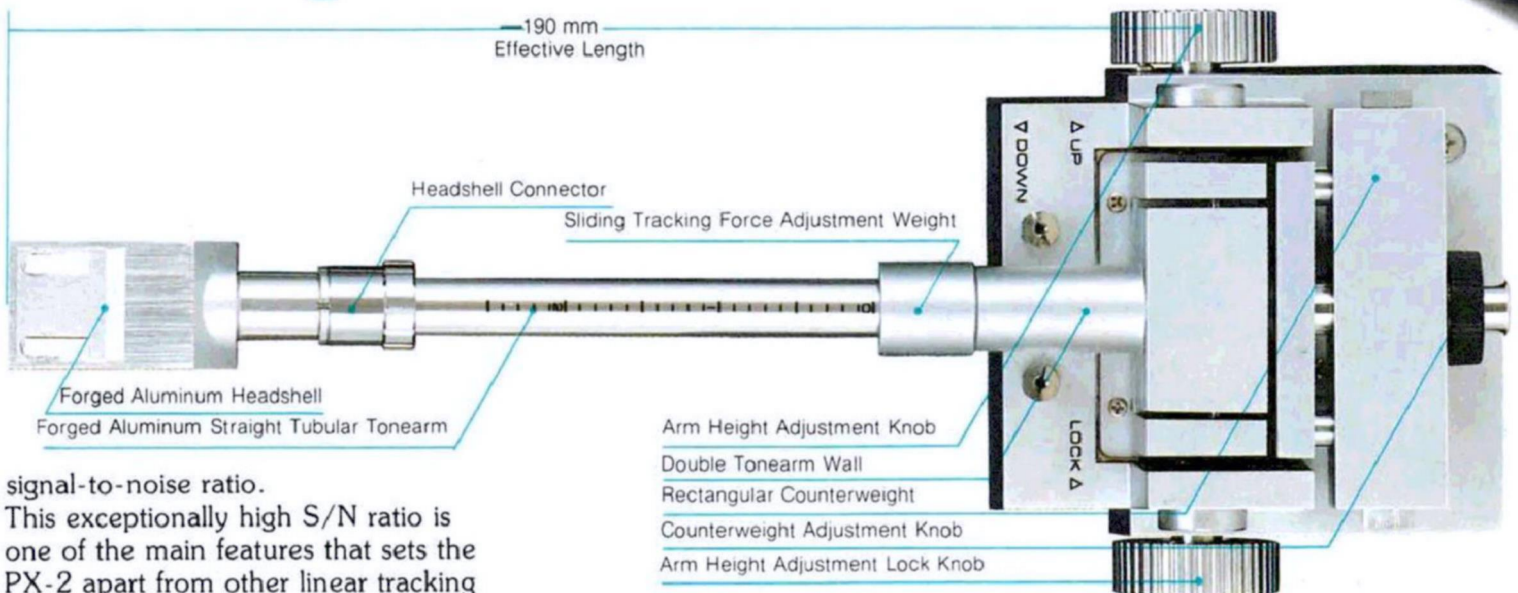

signal-to-noise ratio. This exceptionally high S/N ratio is one of the main features that sets the PX-2 apart from other linear tracking

tolerance of 12 Hz—the frequency where both music and record warp induced frequencies are at negligible levels—with virtually any cartridge you choose, so unavoidable tonearm resonance will have virtually no effect on reproduced sound quality.

### Tonearm Height Adjustment

The PX-2 tonearm can easily be adjusted for perfect horizontality with just about any cartridge. This means that any size cartridge can be used with no loss in vertical tracking accuracy so you always get the

equally outstanding turntable performance. The PX-2 platter is directly driven by a high-precision coreless, slotless Hall element motor with exceptionally high 1 kg·cm starting torque. This top performance

### Direct Drive Motor Construction

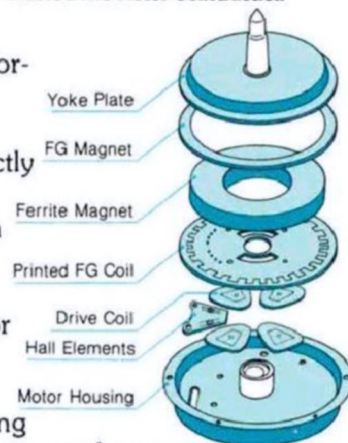

motor in combination with the massive 31 cm (12-1/4"), 2.1 kg platter has

### Turntable Servo System Block Diagram

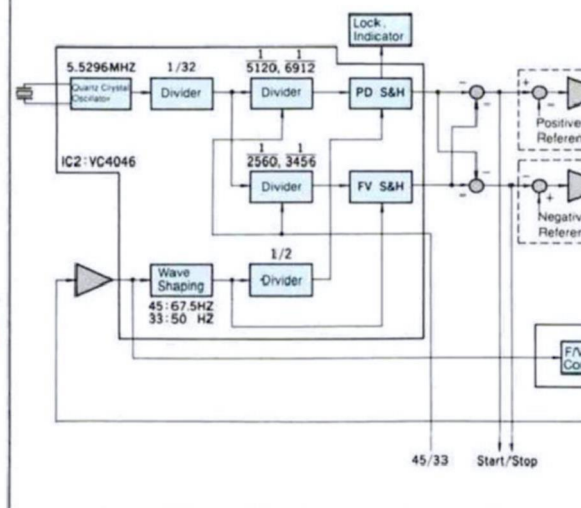

disturbances will have little or no effect on rotational speed. The speed of the motor is precisely controlled by a unique double servo system incorporating both quartz PLL and FG governing techniques. The reason for employing

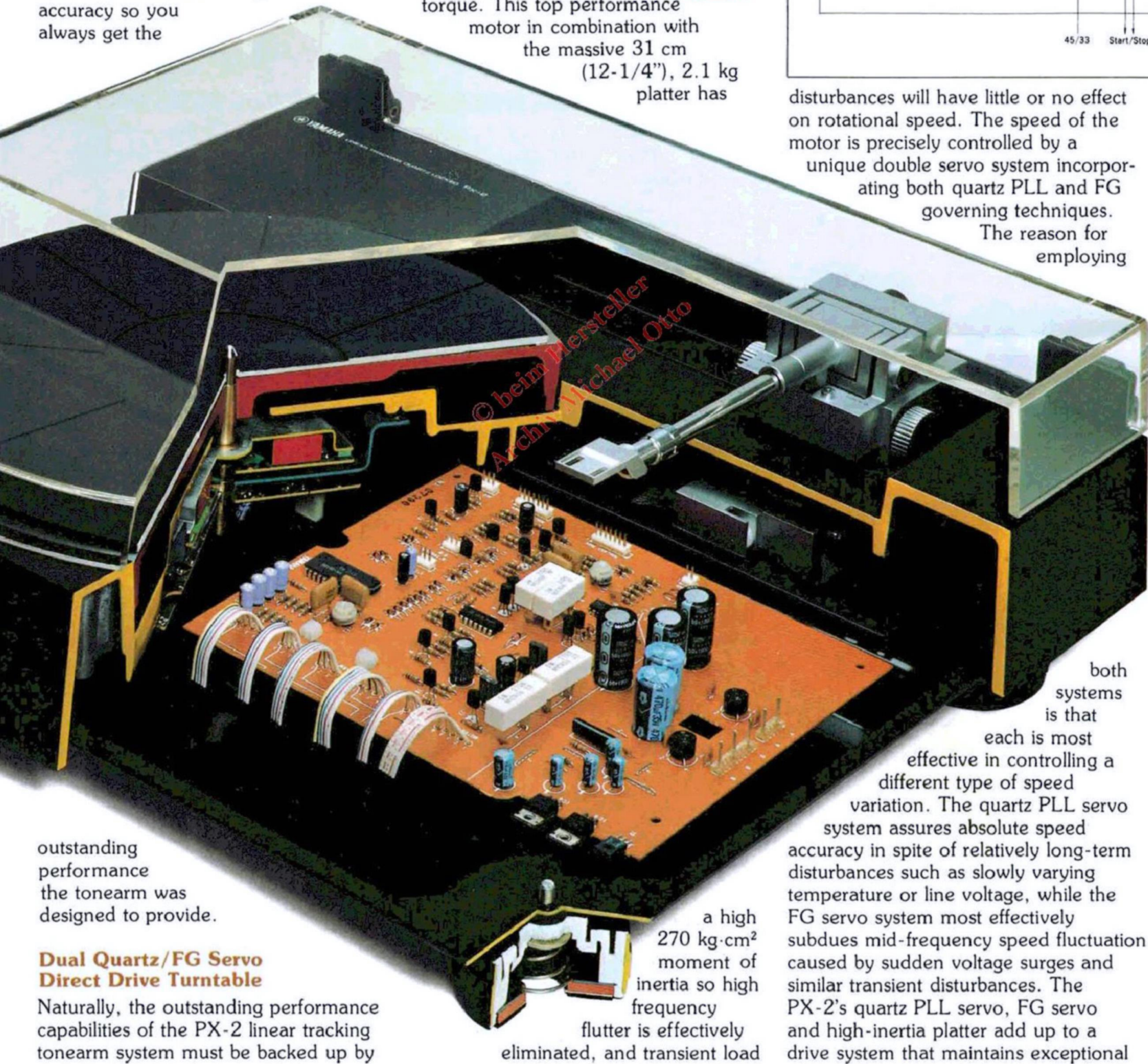

outstanding performance the tonearm was designed to provide.

### Dual Quartz/FG Servo Direct Drive Turntable

Naturally, the outstanding performance capabilities of the PX-2 linear tracking tonearm system must be backed up by

© beim Hersteller  
Archiv Michael Otto

a high 270 kg·cm<sup>2</sup> moment of inertia so high frequency flutter is effectively eliminated, and transient load

both systems is that each is most effective in controlling a different type of speed variation. The quartz PLL servo system assures absolute speed accuracy in spite of relatively long-term disturbances such as slowly varying temperature or line voltage, while the FG servo system most effectively subdues mid-frequency speed fluctuation caused by sudden voltage surges and similar transient disturbances. The PX-2's quartz PLL servo, FG servo and high-inertia platter add up to a drive system that maintains exceptional

# PX-2

Natural Sound Linear Tracking Turntable

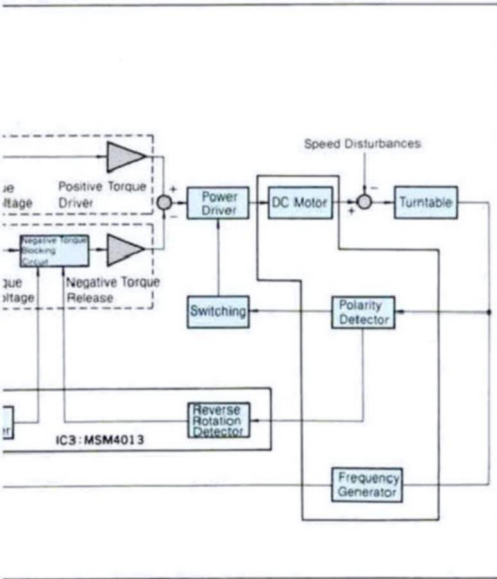

speed stability under virtually any conditions.

The servo system also features a braking system that brings the platter to a quick halt when the tonearm return is activated so changing records is fast and easy.

## Fully Automatic Front Panel Control

A specially developed Yamaha logic IC permits extensive control convenience and flexibility in the PX-2. And all con-

selector matrix lets you initiate automatic lead-in, cue and play with 17 (7"), 25 (10") or 30 cm (12") discs. An opto-electronic disc access control sensor built into the tonearm carriage

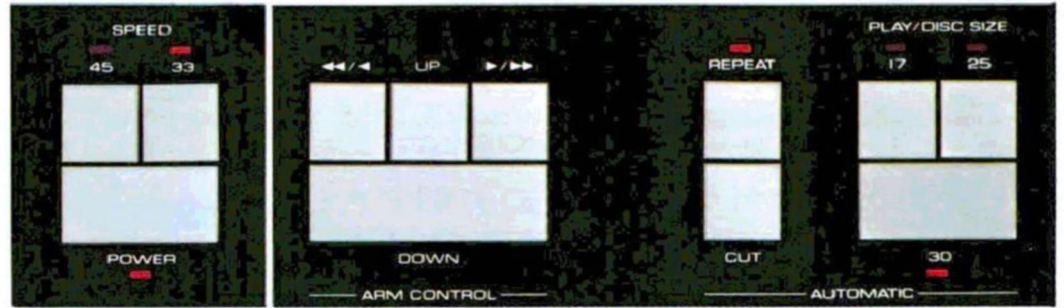

base positions the stylus precisely over the lead-in groove of the selected record. When the record ends, the tonearm automatically raises and returns to its ready position. A Repeat function is also provided that permits automatic repeat playing of a record. Play can be interrupted and the arm automatically returned to its ready position at any time by pressing the Cut button. A manual tonearm control matrix is also provided which permits cueing and manual positioning of the tonearm. The left and right manual tonearm positioning buttons feature two-speed operation: pressing either button firmly causes the tonearm

preventing possible stylus damage due to accidentally dropping the tonearm. Other front panel controls include 33 and 45 rpm speed controls and the power switch.

## Total Human Engineering

All PX-2 control features have been carefully engineered for optimum

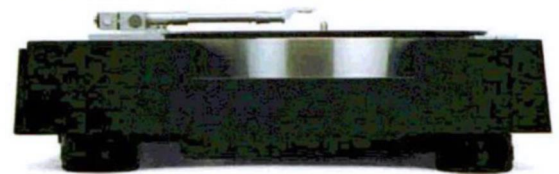

operation ease and minimum chance of operation error. The front panel controls are arranged in an easy-

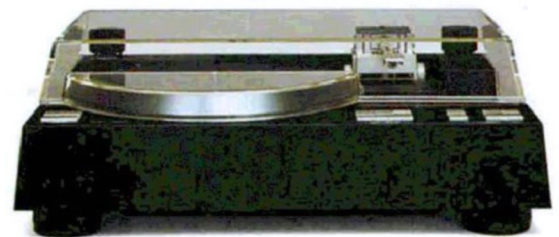

operation layout for fast, error-free activation of all functions, and the dust cover features a sloping front for accurate, easy visual monitoring of tonearm positioning. The tonearm base has a specially designed cutaway, providing fast access for changing records.

## Control System Block Diagram

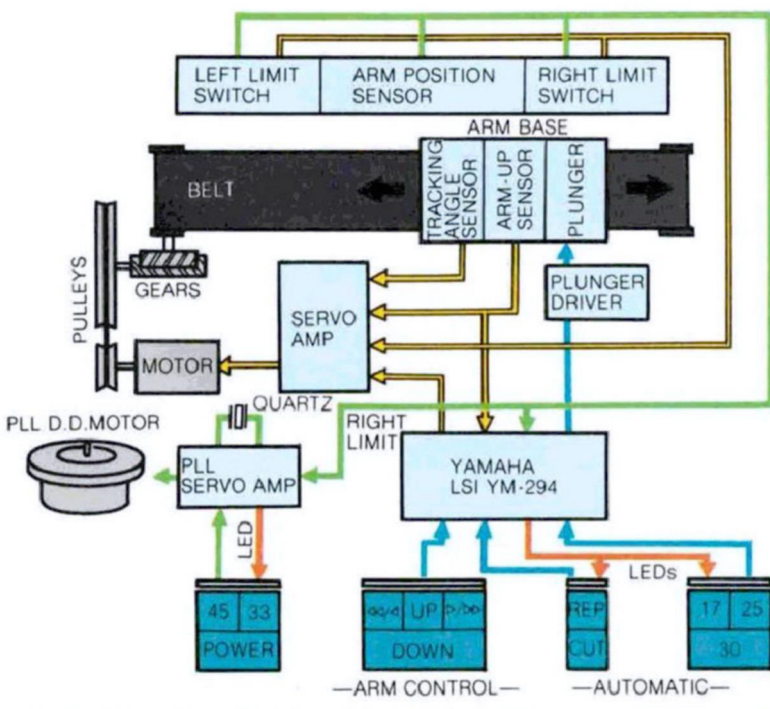

to travel rapidly in the selected direction, and pressing either button lightly causes the tonearm to travel more slowly for accurate positioning. Up and Down cueing buttons activate the electronic tonearm cueing plunger. For convenience, the Up cueing function is

## Sturdy, Resonance-Resistant Construction

The PX-2 turntable base is formed of 5-mm thick diecast aluminum for maximum resistance to both internal and external vibration. Even the dust cover is formed of 5-mm thick acrylic resin and weighs a hefty 1.3 kg. All this solidity and weight guarantees resonance-free performance so inter-modulation distortion and feedback due to external disturbances (such as sound from the speakers reaching the stylus via the turntable base and platter) cannot occur. Unique Yamaha insulator feet incorporating both spring and rubber vibration damping systems provide an extra measure of protection against external disturbances.

control buttons are located on the front panel outside the dust cover so all operations (other than changing records) can be carried out with the dust cover lowered. A Play/Disc Size

is automatically activated if either manual tonearm positioning button is pressed during a play operation. The tonearm is also automatically raised when the power is switched off,

## Forged Aluminum Headshell

Like the rest of the PX-2, the headshell is designed and constructed for

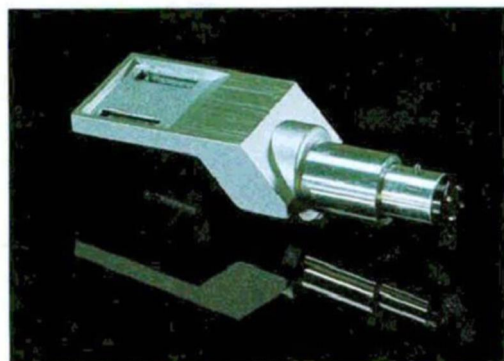

optimum reproduction performance. The headshell is forged of solid aluminum for high rigidity so no resonance can interfere with sound quality, and the cartridge is attached with two bolts and a solid aluminum crossbar rather than the conventional bolts and individual nuts. And since the headshell is electrically conductive, its hum-rejection characteristics are ideal.

## Top-Quality Cable with Gold-Plated Connectors

Even the PX-2 connector cables are special. They are high quality low im-

pedance types that ensure maximum signal transmission efficiency and accuracy. And the phono connectors are plated with gold so they cannot corrode to cause increased contact resistance.

## Other Features

- Accurate sliding tracking force adjustment weight
- LED PLL servo lock indicator
- LED record size and repeat function indicators
- Resonance-damping turntable mat
- Elegant matte black finish

## PX-2 SPECIFICATIONS

TURNTABLE	
Drive System	Quartz PLL/FG (Full Periphery Integration) Servo with Electronic Braking, Direct Drive
Motor	4-Phase, 8-Pole Coreless DC Hall-Effect Motor
Platter	Aluminum Diecast, 31 cm (12-1/2"), 2.1 kg (4 lbs. 10 oz.) Including Rubber Mat
Platter Moment of Inertia	270 kg-cm <sup>2</sup> (Including Rubber Mat)
Start-Up Torque	Greater than 1 kg-cm
Lock-In Torque	450 g-cm
Speeds	33-1/3 and 45 rpm
TONEARM	
Type	Linear Tracking, Straight, Tubular
Drive System	Opto-Electronic Tracking Error Sensor and Coreless DC Servo Motor
Overall/Effective Length	236/190 cm (9-1/4"/7-1/2")
Tracking Force	Static Balance, Sliding Weight 0—2.5 g, 0.1 g increments
Suitable Cartridge Weight	5—11 g (10—16 g with Subweights)
Effective Mass	Tracking Force Proportional, 16.0—18.0 g
Tangential Tracking Error	±0.15° maximum (Stylus Tip Displacement: ±0.5 mm)
Arm Lifter	Electronic, Oil Damped

Arm Height Adjustment	± 4 mm (± 1/6")
Headshell	Forged Aluminum EIA Type, 8.0 g, Gold-Plated Connectors
PU Cable	Low-Impedance Neglex 2496
Resistance	Less than 1 ohm, Connectors to Pin Plugs/Pin Plugs to Connectors
Capacitance	Less than 130 pF

## CONTROL FUNCTIONS

Automatic	Lead-In, Return, Repeat, Arm Up at Power Off
Size Selectors	17 cm (7"), 25 cm (10"), 30 cm (12")
Manual	Arm Up, Arm Down, Cut, 2-Speed Arm Positioning

## CABINET

Base	5 mm Aluminum Diecast, Black Finish
Dust Cover	5 mm Acryl, 1.3 kg (2 lbs. 14 oz.), Removable, Free-Stop Hinges
Insulators	Spring/Rubber

## PERFORMANCE

Signal-to-Noise Ratio	80 dB (DIN B/IEC 98A, Weighted)
Wow and Flutter	0.01% WRMS (FG Direct Measurement)

## GENERAL

Power Supplies	Available for All Areas
Power Consumption	25 W (22 W for General Model)
Dimensions (W x H x D)	493 x 156 x 428 mm (19-3/8" x 6-1/8" x 16-7/8")
Weight	17 kg (37 lbs. 8 oz.)

Specifications subject to change without notice.

For details please contact:

SINCE 1887



# YAMAHA

NIPPON GAKKI CO., LTD. HAMAMATSU, JAPAN