

YAMAHA CT7000

FM STEREO TUNER WITH CERAMIC BLOCK IF FILTER



The CT-7000: distortion characteristics so negligible even the most sensitive testing equipment can't measure them.

Gone are the days when the FM tuner was the weak link in a top-of-the-line stereo system. With the CT-7000 Yamaha gives you clear, distortion-free FM stereo response that measures up to

(and probably surpasses!) every other part of your stereo system. Even if you don't fully understand the technical details of this radically new design you can hear the difference—because the CT-7000

provides studio-like FM stereo even in the most difficult reception areas, with the lowest distortion of any tuner in the world.

Negative Feedback Switching in FM Stereo Decoder Circuit

Widely used in amplifiers for lower distortion and better linearity (same response from bass through treble frequencies), the negative feedback technology in the CT-7000 multiplex circuit is the world's first (patents pending).

This design also prevents intermodulation beat interference, as well as interference from the SCA band. That let us do away with distortion-causing special SCA filters. The result: distortion so low we can't even measure it. The most we can tell you is that at 400Hz, for example, MPX distortion is an incredibly low 0.02%—and even that figure includes the distortion introduced by the measuring instrument itself.

MODULATION RATE VS. TOTAL HARMONIC DISTORTION

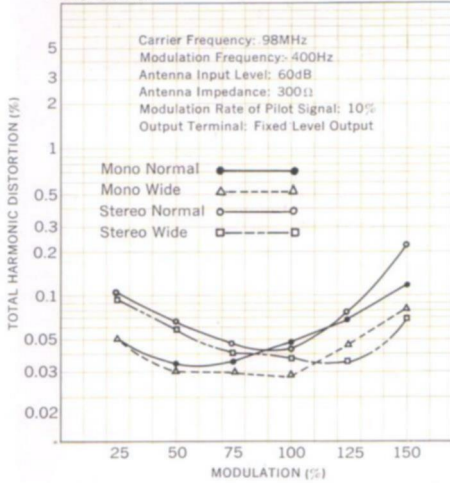

MODULATION FREQUENCY VS. TOTAL HARMONIC DISTORTION

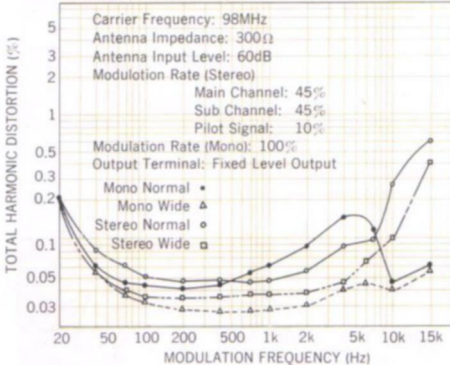

FREQUENCY RESPONSE and STEREO SEPARATION

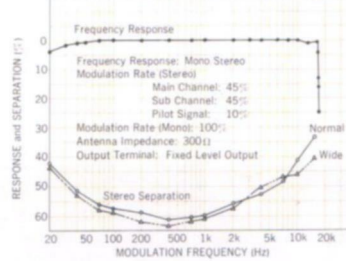

Phase Lock Loop Type MPX Decoder

The PLL circuit in the MPX decoder locks onto the phase of the 38kHz sub-carrier and the 19kHz pilot signal for better phase accuracy, clearer stereo channel separation and lower distortion. It also eliminates the LC type tuning circuit, resulting in better stability despite temperature fluctuations and ageing.

ANTENNA INPUT vs. OUTPUT LEVEL, STEREO SEPARATION and S/N RATIO

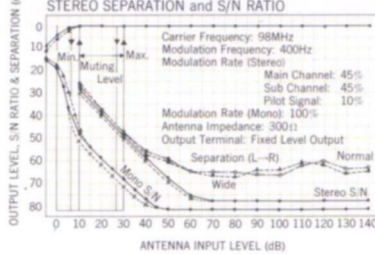

FM IF Stage: Seven-Stage Differential Amplification, Ceramic Block Filter, Discriminator Circuit

Selectivity (the ability to pick a desired signal and reject others on the same frequency band) is usually gained at the expense of higher distortion. But the CT-7000 uses the world's first block of ceramic and LC filters to raise selectivity and cut distortion at the same time (patents pending). Complemented by a new linear phase minimum differential gain deviation discriminator with high-frequency transistor drive (pat. pend.), this section boasts unmeasurably low distortion, in spite of over 85dB alternate channel selectivity and within 1.0dB capture radio. Another reason why the CT-7000 assures brilliant stereo response in any signal area.

CAPTURE RATIO

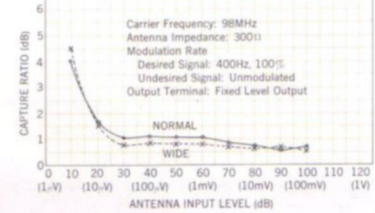

SELECTIVITY

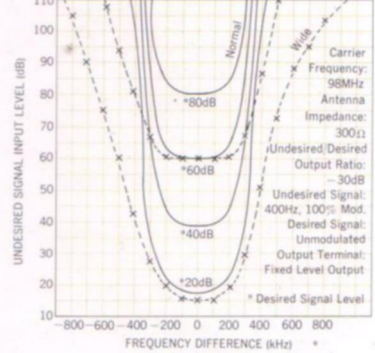

Front End: Dual-Gate MOS Type FET and World's First 7-Gang Tuning Capacitor

A radical new Yamaha design that means excellent sensitivity (ability to receive weak signals), plus amazing IF interference rejection and 120dB (IHF) spurious signal rejection—characteristics so outstanding that they exceeded test instrument capabilities. To make the most of this breakthrough, the CT-7000 mixer stage is completely redesigned, providing immunity to overload, oscillator pulling and intermodulation distortion in high signal strength areas—even up to an astounding 140dB antenna input signal (nearly ten times stronger than normal). That means the same steady, sure reception even if you live practically next door to a strong FM station.

ANTENNA INPUT vs. TOTAL HARMONIC DISTORTION

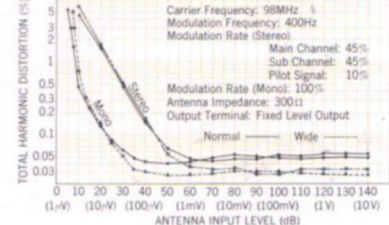

INTERMODULATION CHARACTERISTICS

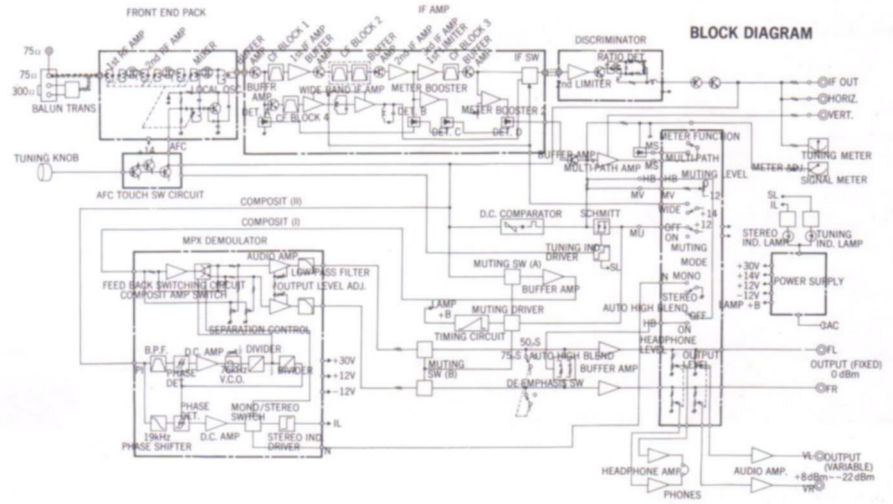
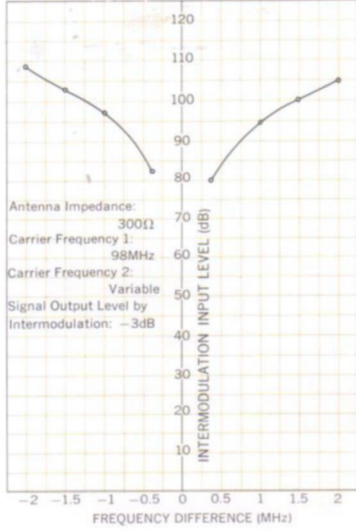

YAMAHA NATURAL SOUND FM STEREO TUNER CT-7000

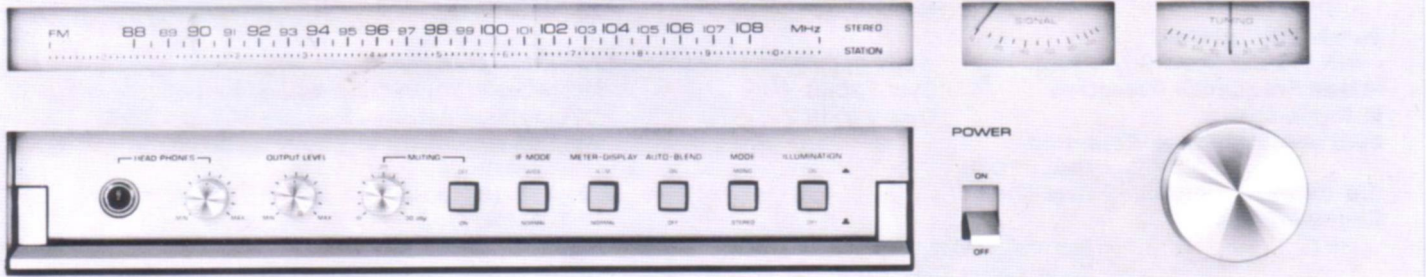

Ultra-Effective Low Pass Filter

Another Yamaha breakthrough. Its all-new design assures almost complete elimination of switching and carrier signals from the output for clear, undistorted response throughout the whole frequency range.

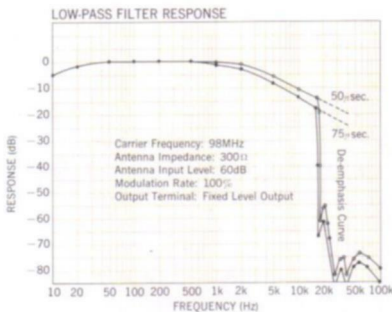

Auto High-Blend Circuit

Blending the stereo channel signals in the high frequencies only can reduce noise accompanying a weak signal without completely destroying the stereo effect. This circuit works in two stages, depending upon signal strength, automatically blending the required amount of high-frequency stereo.

Double FM Muting Circuit

One stage at the MPX input section, another at the output side. This eliminates interstation noise and also cuts shock noise when a station is reached, or when the CT-7000 is switched on or off. The muting effect is continuously variable, to match the reception area.

Two Meters, Three Functions

The signal strength meter has an extra-wide range to show up to 100dB antenna input with no peak-out. Flick the selector switch and it becomes a signal minus multipath meter—it shows how “clean” the received signal is, for precise antenna positioning. The center tuning meter helps you tune right on the station.

Unique Yamaha Auto-Touch Tuning

When you touch the knob a special circuit shuts off the AFC. Then, when the station is tuned, release the knob and the AFC comes on automatically.

AFC Station Indicator

Tune across the dial and the lamp will glow softly in the area of an FM station. Once you have tuned in and released the knob, the lamp will glow brightly to show that the AFC circuit is operating.

Sophisticated Low-Distortion OTL Headphone Amp

Connectors for 300Ω Feeder and 75Ω Coaxial Cable

Top-Performance Low-Distortion Audio Amp

Output Level Control

Slide Rule Dial/Pointer System

With switchable dial illumination.





Build a Full System

Match the CT-7000's superb performance and styling with a full Yamaha stereo system: CA-1000 stereo amplifier, YP-800 stereo turntable and TB-700 cassette deck with Dolby recording & playback.



SPECIFICATIONS

Specifications subject to change without notice.

	Guaranteed	Typical
Tuning Range	88-108 MHz	
Sensitivity (mono)		
IHF	Normal: better than 2.5 μ V Wide: better than 3.2 μ V	2.0 μ V 2.5 μ V
DIN (40 kHz Dev.; S/N 26dB)	Normal: better than 1.6 μ V Wide: better than 2.5 μ V	
Sensitivity (stereo)		
DIN (40 kHz Dev.; S/N 46dB)	50 μ V	
Image Frequency Rejection	Over 120dB	
IF Rejection	Over 120dB	
Spurious Response Rejection	Over 120dB	
AM Rejection (IHF)	Over 60dB	
Capture Ratio		
1mV	Normal: better than 1.3dB Wide: better than 1.0dB	1.0dB 0.7dB
10 μ V	Normal: better than 2.0dB Wide: better than 3.0dB	
100mV	Normal: better than 1.0dB Wide: better than 1.0dB	0.7dB 0.6dB
Selectivity		
IHF (75 kHz Dev.)	Normal: over 80dB Wide: over 18dB	85dB
DIN (\pm 300Hz; 40kHz Dev.)	Normal: over 65dB Wide: over 10dB	
\pm 500kHz	Normal: over 90dB Wide: over 35dB	40dB
Signal/Noise Ratio (mono)		
IHF (75kHz Dev.)	Over 78dB	
DIN (40kHz Dev.)	Over 72dB	
Signal/Noise Ratio (stereo)		
IHF (75kHz Dev.)	Over 75dB	
DIN (40kHz Dev.)	Over 69dB	
Total Harmonic Distortion (antenna level: 1mV)		
Mono		
IHF (400Hz; 75kHz Dev.)	Normal: less than 0.08% Wide: less than 0.08%	0.06% 0.04%
DIN (1kHz; 40kHz Dev.)	Normal: less than 0.08% Wide: less than 0.08%	0.06% 0.04%
IHF (50-10,000Hz; 75kHz Dev.)	Normal: less than 0.3% Wide: less than 0.15%	0.2% 0.08%
DIN (50-10,000Hz; 40kHz Dev.)	Normal: less than 0.3% Wide: less than 0.15%	0.2% 0.08%
Stereo		
IHF (400Hz; 75kHz Dev.)	Normal: less than 0.08% Wide: less than 0.08%	0.06% 0.04%

	Guaranteed	Typical
75kHz Dev.)	Wide: less than 0.08%	0.04%
DIN (1kHz; 40kHz Dev.)	Normal: less than 0.08% Wide: less than 0.08%	0.06% 0.04%
IHF (50-10,000Hz; 75kHz Dev.)	Normal: less than 0.5% Wide: less than 0.2%	0.3% 0.15%
DIN (50-10,000Hz; 40kHz Dev.)	Normal: less than 0.5% Wide: less than 0.2%	0.3% 0.15%
Stereo Separation		
IHF (400Hz; 75kHz Dev.)	Normal & wide: 50dB	
DIN (1kHz; 40kHz Dev.)	Normal & wide: 50dB	
IHF (50-10,000Hz; 75kHz Dev.)	Normal: 35dB Wide: 40dB	
DIN (50-10,000Hz; 40kHz Dev.)	Normal: 35dB Wide: 40dB	
Frequency Response		
50-10,000Hz	\pm 0.3dB	
30-15,000Hz	+0.5dB, -1.0dB	
Sub-Carrier Suppression	Over 70dB	
Muting Override Signal Level	3-30 μ V	
Stereo Level	3-30 μ V	
Auto Blend Level	I: 100 μ V, II: 1mV	

GENERAL

Transistors	108
FETs	12 (dual-gate MOS: 3, junction: 9)
Diodes	33
Zener Diodes	9
ICs	7
Two-Element Ceramic Filter	1
Four-Element Ceramic Filter	1
Two-Element Ceramic Block Filters	2
Headphone Output	4-16 Ω
Fixed Output	775mV
Variable Output	2V~70mV variable
Antenna Input Impedance	300 Ω (balanced), 75 Ω (unbalanced)
Power Source	AC 117V, 50/60Hz
Power Consumption	23W (illum. off: 13W)
AC Outlet	1 (unswitched, 500W)
Cabinet	American walnut
Front Panel	Hairline brushed aluminum
Dimensions (W×H×D)	436×144×352mm (17.2"×5.7"×13.9")
Weight	13kg (28.6 lbs.)

For details please contact:

SINCE 1887  **YAMAHA**
NIPPON GAKKI CO., LTD. HAMAMATSU, JAPAN