

YAMAHA NATURAL SOUND SEPARATE COMPONENTS

C-45/C-65/C-85/M-45/M-65/M-85/T-85

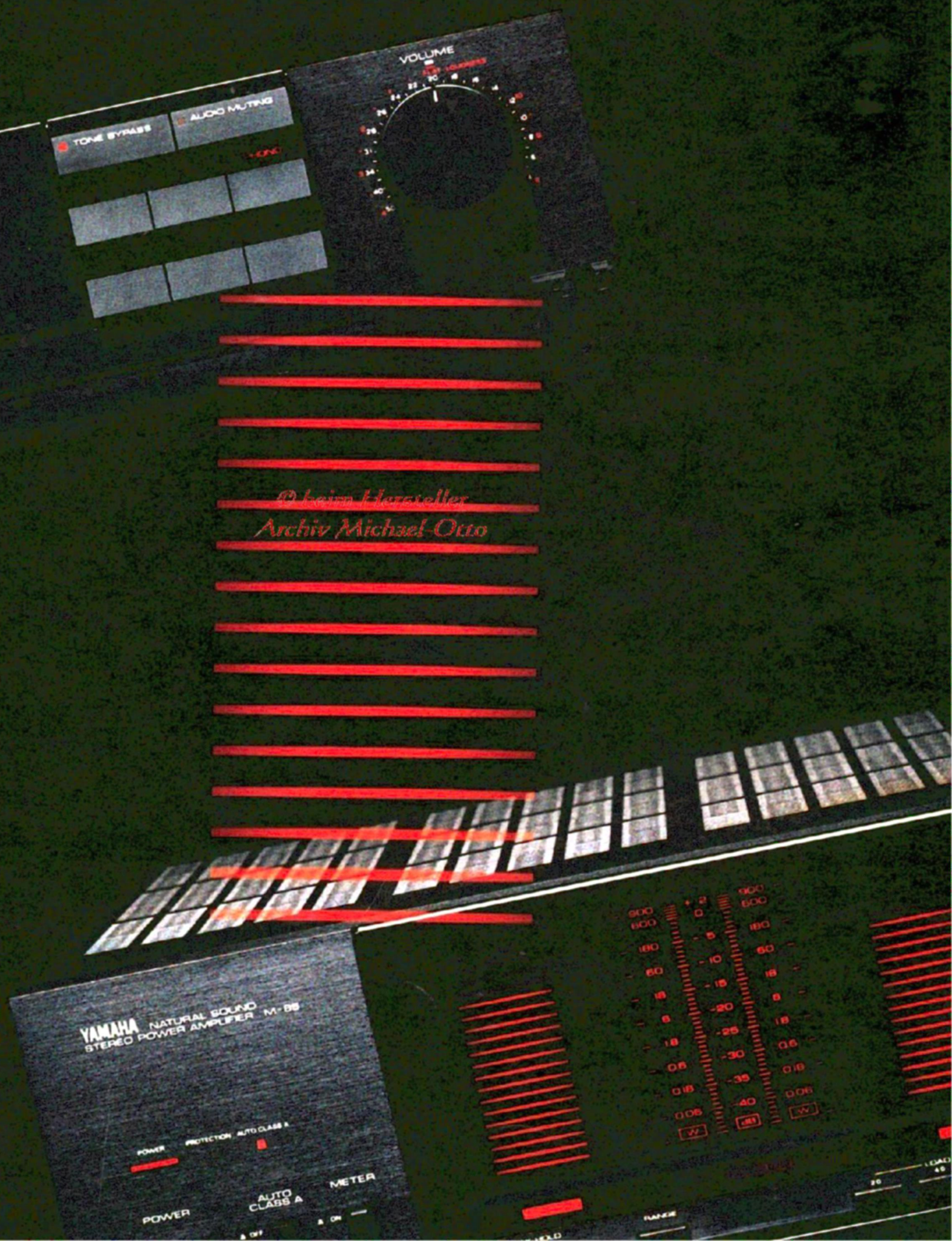

*© beim Hersteller
Archiv Michael-Otto*

THE ULTIMATE IN AUDIO SOPHISTICATION



Our C-85 Stereo Control Amplifier and M-85 Stereo Power Amplifier offer an incredible combination of power and musical clarity. No effort has been spared to make these models the finest of their type. The M-85, with 250 watts of peak power per channel, and its companion the C-85, with a host of unique convenience features, will surpass your every expectation.

C-85 Natural Sound Stereo Control Amplifier

The C-85 incorporates all of the technological refinements found in our C-45 and C-65 models, and additional performance features. The C-85 utilizes a Zero Distortion Rule MC head amplifier for clarity and precision across the audible spectrum. The phono EQ stage also includes Zero Distortion Rule, DC Servo circuitry, Current Noise Suppression circuitry, and the Extended Rolloff Equalizer for unparalleled

phono reproduction purity. The C-85 is a wonder of convenience, with our New Continuously Variable Loudness Control, switchable MM/MC phono amplifier gain, Rec Out selector, MM/MC cartridge load selector, backlit input selector indicators, Tone Bypass switch, and a subsonic filter. A special two-band parametric equalizer provides response control to suit room acoustics and listening tastes.

Those who seek the ultimate in audio sophistication will appreciate the Yamaha C-85. It is the new standard in stereo control amplifiers.

M-85 Natural Sound Stereo Power Amplifier

The M-85 is Yamaha's finest Natural Sound power amplifier, offering massive output power and extreme reproduction purity for the



*© beim Hersteller
Archiv Michael-Otto*

discriminating audiophile. It delivers an astounding 250 watts of power per channel into an 8 ohm load with a mere 0.003% THD. In short, the M-85 offers power to suit any listening requirement. Further, Auto Class A Power and Zero Distortion Rule circuitry make this one of the cleanest sounding amplifiers available. Regardless of the type of music you enjoy—rock, jazz, classical, or anything in between—the M-85 responds with dynamic power on demand, making the most of today's dynamic audio sources. It is capable of driving up to three speaker pairs independently, simultaneously, or in any combination of two. You'll appreciate its heavy-duty speaker connection terminals, wide-range LED peak power level meters, meter display load selector, meter Peak Hold and Range selectors, and full overload protection circuitry. The M-85 is an outstanding achievement in power amplifier design.

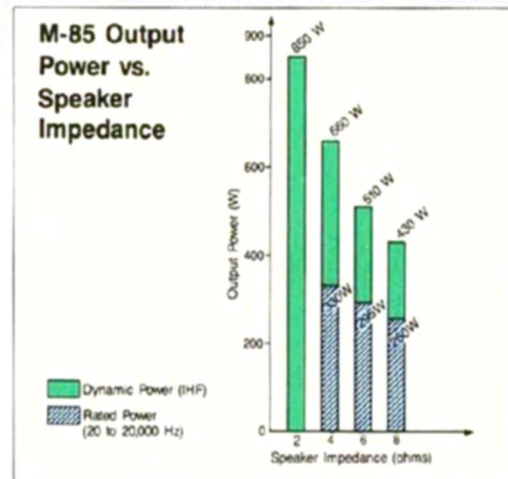

C-85 SPECIFICATIONS

Input Sensitivity/Impedance

Phono MC 100 μ V/100 ohms
 Phono MM 2.5 mV/100 ohms,
 47 k-ohms (220, 330 pF)

CD/Video/Tape/Tuner 150 mV/47 k-ohms

Input Sensitivity (New IHF)

Phono MC/MM 33 μ V/0.83 mV
 CD/Video/Tape/Tuner 50 mV

Maximum Input Level (1 kHz, 0.01% THD)

Phono MC/MM 20 mV/500 mV

Output Level/Impedance

Pre Out 1.5 V/47 ohms
 Rec Out 150 mV/600 ohms

Headphone Output Level/Impedance

(1 kHz, 0.01% THD) 6 V/100 ohms

Total Harmonic Distortion (3 V)

Phono MC to Rec Out 0.001%

Phono MM to Pre Out 0.001%

CD/Video/Tape/Tuner to Pre Out 0.001%

Intermodulation Distortion

CD/Video/Tape/Tuner, 5 V Output,
 Tone Bypass On 0.002%

Frequency Response (Tone Bypass On)

CD/Video/Tape/Tuner

(20 to 20,000 Hz) +0, -0.2 dB

RIAA Deviation (Phono MC/MM)

20 to 20,000 Hz \pm 0.2 dB/ \pm 0.2 dB

10 to 100,000 Hz \pm 0.5 dB/ \pm 0.5 dB

Signal-to-Noise Ratio (IHF-A-Network)

Phono MC

(500 μ V, Input Shorted) 91 dB

Phono MM

(50 mV, Input Shorted) 95 dB

Video/Tape/Tuner

(150 mV, Input Shorted) 106 dB

CD/Video/Tape/Tuner 106 dB

Phono MC/MM 81 dB/83 dB

CD/Video/Tape/Tuner 103 dB

Channel Separation

Phono MM, Input Shorted

(40 Hz/1 kHz/10 kHz) 85/80/70 dB

Video/Tape, 5.1 k-ohms

(40 Hz/1 kHz/10 kHz) 85/70/50 dB

Parametric Equalizer Characteristics

Frequency Control

(Low) 31.5 to 800 Hz

(High) 800 to 20,000 Hz

Level Control (Low/High) \pm 12 dB

Bandwidth Control

(Low/High) Q; 0.3 to 3.0

Filter Characteristics

Low (Subsonic) 15 Hz, -12 dB/oct

Audio Muting -20 dB

Power Consumption 30 W

Dimensions

(W x H x D) 435 x 95 x 380 mm

(17-1/8" x 3-3/4" x 14-15/16")

Weight 6.8 kg (15 lbs.)

M-85 SPECIFICATIONS

Minimum RMS Output Power per Channel

(8 ohms) 260 Watts

from 20 to 20,000 Hz at no more than

0.003% Total Harmonic Distortion

(6 ohms) 295 Watts

from 20 to 20,000 Hz at no more than

0.007% Total Harmonic Distortion

(4 ohms) 330 Watts*

from 20 to 20,000 Hz at no more than

0.02% Total Harmonic Distortion

*Europe, Britain and Australia 340 W

Auto Class A Operating Range

(8 ohms) 30 W

Dynamic Power per Channel (1 kHz)

8 ohms 430 W

6 ohms 510 W

4 ohms 660 W

2 ohms 850 W

Dynamic Headroom

8 ohms 2.18 dB

6 ohms 2.38 dB

4 ohms 3.11 dB

Power Bandwidth (8 ohms)

(Half Rated Power) 10 to 60,000 Hz

Damping Factor (8 ohms, 1 kHz) 230

Input Sensitivity/Impedance

(Main In) 1.55 V/20 k-ohms

Frequency Response (Main In)

(20 to 20,000 Hz) +0, -0.2 dB

Signal-to-Noise Ratio (IHF-A-Network)

Input Shorted 128 dB

5.1 k-ohms 122 dB

Residual Noise (IHF-A-Network) 16 μ V

Total Harmonic Distortion (Main In)

(8 ohms, Half Rated Power) 0.002%

Intermodulation Distortion

Aux/Tape/Tune

(8 ohms, Half Rated Power) 0.003%

Channel Separation (Input Shorted)

1 kHz/10 kHz 89 dB/76 dB

Power Consumption

U.S.A. 600 W

Canada 1100 W/1300 VA

Europe and Australia 1700 W

Other Areas 850 W

Dimensions

(W x H x D) 435 x 165 x 425 mm

(17-1/8" x 6-1/2" x 16-3/4")

Weight 23 kg (50 lbs. 10 oz.)

Specifications subject to change without notice.

C-85 Gold-Plated Input Terminals

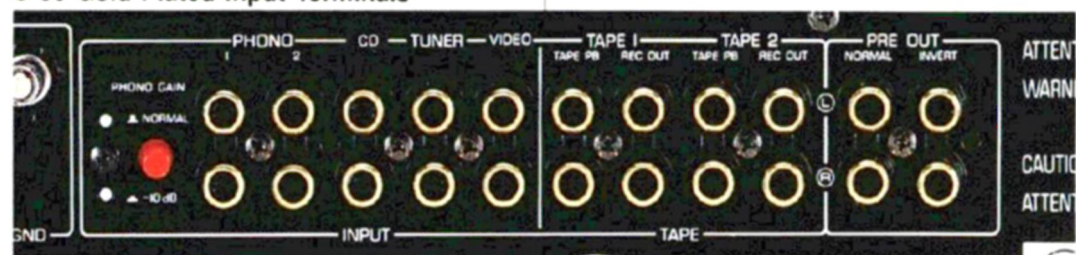

MAXIMUM TUNING PURITY UNDER ALL CONDITIONS

Unlike direct music sources such as records, tape and Compact Disc, a broadcast signal is subject to varying conditions before it reaches the listener's receiving equipment. Because of this the requirements for top tuner performance are particularly severe. In addition to providing pure, distortion- and noise-free signal processing, a truly fine tuner must be able to handle signals of widely varying strength and quality, with minimal variation in output sound quality. Yamaha tuner technology achieves this to the highest degree, giving you uncompromising music reproduction quality under any reception conditions.

The New Computer Servo Lock (CSL) Tuning System

While a number of different tuning methods are employed in today's tuners, no single method is ideally suited to all reception conditions. A tuner may perform flawlessly when receiving relatively weak signals, but will exhibit a significant increase in distortion—and thus a loss of audio quality—when faced with strong local signals. For this reason the Yamaha Computer Servo Lock (CSL) Tuning System incorporates two separate reception modes: PLL synthesized tuning and voltage servo tuning. Just having these two modes available would be enough for many listeners, but Yamaha has gone one step further by incorporating a microprocessor which chooses the appropriate

tuning mode automatically. Initially the PLL mode is engaged so that the tuner can precisely lock onto even the faintest broadcast signals. Then, once the desired station has been located, the microprocessor analyzes the incoming signal in terms of its strength and interference levels. If the received signal is found to be weak or high in interference, the PLL mode is automatically selected to ensure optimum reception quality. If, however, the signal is determined to be of sufficiently high quality—it is strong with little interference—the voltage servo tuning mode is selected, allowing for optimum performance with this type of signal.

The following chart compares the performance of the PLL and voltage servo tuning systems:

© beim Hersteller
Archiv Michael Otto

| | PLL |
|---------------------------|--------------|
| No-signal point tuning | Possible |
| Weak-signal reception | Possible |
| Signal drift tracking | Not possible |
| Reception freq. stability | Excellent |
| Signal-to-noise ratio | Good |
| Total harmonic distortion | Good |

| | Voltage Servo |
|---------------------------|---------------|
| No-signal point tuning | Not possible |
| Weak-signal reception | Possible |
| Signal drift tracking | Excellent |
| Reception freq. stability | Good |
| Signal-to-noise ratio | Excellent |
| Total harmonic distortion | Excellent |

Digital Fine Tuning

Despite the incredible sophistication of digital synthesizer tuning, the lack of manual control over the

tuning process eliminates fine tuning capability, often desirable when trying to "tune out" interference from strong adjacent signals. Yamaha restores this important measure of control with manual digital fine tuning capability. An Up/Down rocker type tuning panel allows you to tune in fine increments of 0.01 MHz for FM broadcasts (1 kHz for AM), beyond a station's fundamental frequency. This is useful when trying to tune a relatively weak signal interfered with by an adjacent strong signal. By moving in successive fine increments away from the desired station's fundamental frequency, you can manually pinpoint the exact point on the signal's selectivity curve to effectively minimize the influence of the interfering signal while maintaining optimum stereo reception with low distortion characteristics. When tuning in areas where the band is crowded with stations close together on the dial, or where local interference introduces reception problems, this added tuning precision provides a marked improvement in reception quality.

Zero Intermodulation Mixer

Front-end intermodulation distortion caused by spurious signal interference is eliminated with this advanced circuit configuration. The Zero IM Mixer effectively cancels spurious interference, dramatically reducing cross modulation and intermodulation distortion. It also delivers the quality of optimum-signal-strength reception even with exceptionally strong (120 dBf) signals.

RF Servo Gain Control

When the RF signal is free from interference and is not too strong, the highest quality reception is obtained with the RF stage operating at full gain for maximum sensitivity. But when the frequency of an interference signal is

New Computer Servo Lock Tuning System Block Diagram

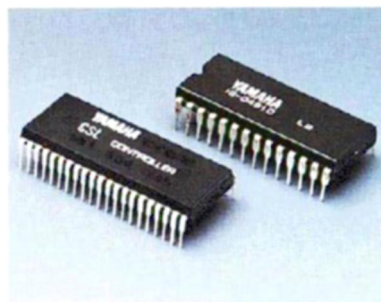
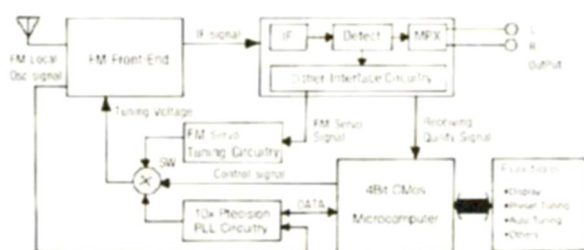

New CSL ICs

close to that of the RF signal, or if the signal is excessively strong, intermodulation distortion and saturation of the RF stage can result. RF servo gain control is employed to adjust the amount of gain automatically so that interference is rejected. This reduces intermodulation distortion dramatically, and provides the optimum balance of sensitivity, signal-to-noise ratio, and high sound quality.

Selectable Normal or Direct RF Modes

An extremely strong RF signal can actually result in degraded reproduction performance due to saturation and distortion of the first RF amplifier stage. The T-85 offers a way to avoid this problem with a front-panel switch that actually bypasses the RF amplifier, feeding the signal directly to the mixer stage. Although the RF Servo Gain Control system means that an extremely wide range of signal strength can be handled with no problem, the RF Mode Normal/Direct switch is provided—just in case you're faced with an unusually strong signal.

Four IF Modes, Automatic or Manual Selection

IF selectivity, or reception bandwidth, is a significant factor influencing reception quality with a broad variety of signals. A broad bandwidth, for example, provides optimum reception quality with signals that are relatively free from interference, while a narrow bandwidth is ideal for rejecting interfer-

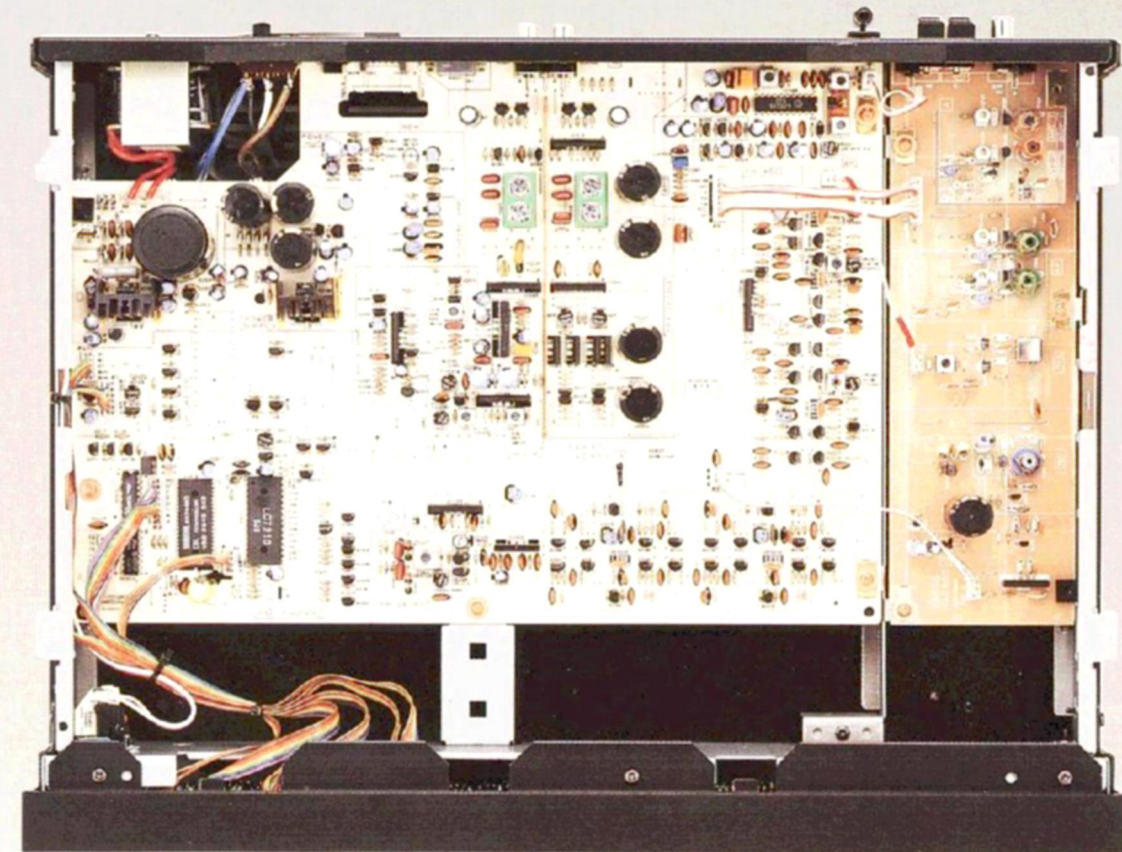

ence and achieving optimum quality with stations in crowded areas of the broadcast band. The latest Yamaha system provides a choice of four IF modes: super-wide, wide, narrow and super-narrow. The listener can select the mode that provides the best quality manually, or engage the auto-selection feature which will make the choice automatically. Further, the selected IF mode (including manual or auto selection) is programmed into the T-85's 20-station random-access preset memory along with the station frequency, so that ideal reception quality is achieved whenever that station is selected.

Low-Distortion High-Separation Pure Stereo MPX Demodulator

The multiplex demodulator is a critical stage in any tuner. It is here that the left- and right-channel audio signals are finally separated from the RF signal, so any inaccuracies in the demodulation process lead to degraded sound quality. The new Yamaha Low-Distortion High-Separation Pure Stereo MPX Demodulator ensures uncompromising demodulation performance by multiplying a pure sine wave with the detector output signal. This eliminates the need for "anti-birdy" filters, so output audio frequency response is not limited. The MPX circuitry can handle signals with extended range and perfectly flat frequency response with virtually no 38 kHz high-frequency interference in the audible range. The perfectly flat phase characteristics achieved by this system mean exceptionally high separation throughout all bands. Further, the relatively simple circuitry of the low-noise high-linearity MPX section, incorporating high-speed amplifiers and an anti-interference PLL circuit, means high-frequency beat distortion is eliminated for all-band low-distortion performance.

38 kHz Harmonic Modulation Response Characteristics

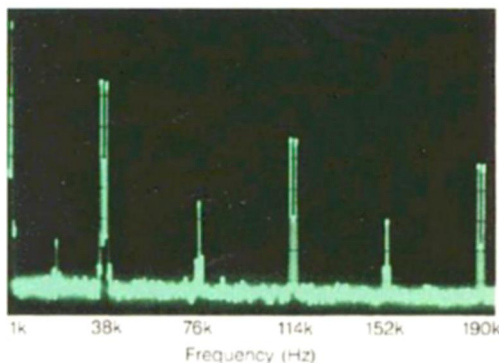

With conventional switching type MPX demodulators, considerable 38 kHz harmonic modulation is present.

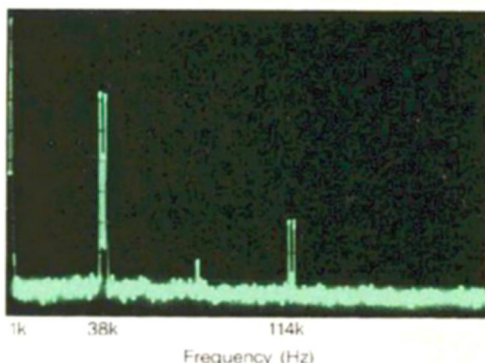

The Yamaha Pure Stereo MPX Demodulator greatly reduces 38 kHz harmonic modulation, contributing to low distortion and high separation in all bands.

UNCOMPROMISING PERFORMANCE FOR THE PURIST

T-85 Natural Sound AM/FM Stereo Tuner

The T-85 Natural Sound AM/FM Stereo Tuner incorporates the most advanced Yamaha tuner technology, making it the uncompromising choice for truly discriminating audio enthusiasts. The T-85 combines a number of proven Yamaha technologies and original features with sophisticated innovations that make it a reference standard in terms of sound quality, reception accuracy and operating ease. Naturally, the T-85 is carefully designed to match the new separate control and power amplifiers in both electrical performance and styling. The T-85 is a must-see-and-hear model for the high-performance separates enthusiast who will accept nothing less than the very best.

CSL Achieves Exceptional Linearity and Low Noise Throughout Entire Band

The New Computer Servo Lock Tuning (CSL) system described on the preceding pages achieves stunning levels of performance in the T-85. First and foremost, it provides ideal reception performance under virtually any signal conditions. Also, the design of this system ensures that the tuning voltage itself is completely unaffected by noise from the PLL stage, so the signal-to-noise ratio of the local oscillator depends only on the inherent noise characteristics of the parts making up the local oscillator circuitry. These, of course, have been painstakingly selected to ensure an absolute minimum of noise. The overall result is a remarkably high signal-to-noise ratio across the entire 87.5 MHz to 108.0 MHz band (98 dB mono, 90 dB stereo),

with unprecedented linearity throughout the same range.

Four Different Tuning Modes

The T-85 offers auto-search and manual tuning in addition to the preset and fine tuning functions. In the Auto Search mode, the tuner scans the band in the specified Up or Down direction until a strong station is found. In the Manual mode, single-step tuning makes it possible to tune to a station's exact frequency for easy tuning of even weak broadcasts.

20-Station Random Access Preset Tuning

Up to 20 different station frequencies can be stored in memory for instant, accurate tuning at the touch of a button. Any combination of AM and FM stations can be programmed. To tune in a preset station, simply touch the appropri-

ate button and the station will be precisely tuned immediately, for real operating ease and convenience. Station frequency indicator cards are supplied, so you can label your presets for faster, easier station selection.

Station Status Memory

When you enter a particular station into the T-85's preset memory, a few more factors than just the station's frequency are memorized. The tuner remembers whether the Auto Stereo or Mono mode was set, whether the Dynamic Auto Blend function was on or off, whether the Direct or Normal RF mode was selected, whether any manual fine tuning was employed, and which of the four possible IF modes was selected. That way, all necessary parameters for optimum station reception are recalled simultaneously with the station's frequency whenever the preset memory is used.

Last Channel Memory

This handy feature eliminates the need to retune your favorite station each time you turn the power on. When power to the T-85

is switched on, the last station tuned in before the power was turned off is automatically re-selected.

12-Segment Signal Quality Meter

This easy-to-read meter provides an accurate reading of overall signal quality, making it easy to achieve the best possible reception with the manual and digital fine tuning functions. This metering system provides a truly meaningful indication of not just signal strength, but actual signal quality, so that the highest display reading shows the optimum blend of signal strength and signal purity. This is especially helpful when tuning manually with the digital fine tuning control, since it gives a visual indication of the desired tuning point in addition to confirmation by ear.

Dynamic Auto Blend Circuit

When signal quality is low, stereo programs tend to lose quality and suffer increased distortion and noise more than monaural programs do. This special circuit compensates for this by automatically blending the left and right channels of a stereo program when signal quality drops below the limit of acceptable sound quality. The result is greatly reduced noise and distortion with enhanced intelligibility on programs that would otherwise be unlistenable. This circuit is "dynamic," too, automatically providing the optimum degree of blend for the prevailing signal conditions.

Other T-85 Features

- * High/Normal Line Out Terminals
- * One-Touch F Type Connector
- * Low-Impedance AM Loop Antenna
- * Large, Bright Digital Frequency Display

T-85 SPECIFICATIONS

| | |
|--|------------------------|
| FM SECTION | |
| 50 dB Quietening Sensitivity (IHF, 75 ohms, Super Narrow) | |
| Mono | 1.6 μ V (15.3 dBf) |
| Stereo | 20 μ V (37.2 dBf) |
| Image Rejection Ratio 95 dB | |
| IF Rejection Ratio 115 dB | |
| Spurious Rejection Ratio 110 dB | |
| AM Suppression Ratio 70 dB | |
| Capture Ratio (Super Wide) 1.2 dB | |
| Alternate Channel Selectivity (Super Narrow) 90 dB | |
| Signal-to-Noise Ratio (IHF) | |
| Mono/Stereo | 98 dB/90 dB |
| Harmonic Distortion (1 kHz) | |
| Mono | 0.03%/0.02% |
| Wide/Super Wide | 0.04%/0.03% |
| Stereo Separation (1 kHz, Super Wide) 68 dB | |
| Frequency Response | |
| 50 Hz to 10 kHz | +0.2, -0.3 dB |
| 20 Hz to 15 kHz | +0.2, -0.5 dB |
| Sub-Carrier Product Ratio 65 dB | |
| AM SECTION | |
| Sensitivity 250 μ V/m | |
| Selectivity (1 kHz, Super Wide) 30 dB | |
| Signal-to-Noise Ratio (400 Hz) 55 dB | |
| Harmonic Distortion (400 Hz) 0.2% | |
| AUDIO SECTION | |
| Output Level/Impedance | |
| FM (100% mod., 1 kHz) | |
| Normal | 0.5 V/2.6 k-ohms |
| High Level | 1 V/1 k-ohms |
| AM (30% mod., 400 Hz) | |
| Normal | 0.15 V/2.6 k-ohms |
| High Level | 0.3 V/1 k-ohms |
| GENERAL | |
| Power Consumption 17 W | |
| Dimensions (W x H x D) 435 x 93.5 x 357 mm (17-1/8" x 3-5/8" x 14") | |
| Weight 5.0 kg (11 lbs.) | |

Specifications subject to change without notice.



PERFECTION IN AUDIO DESIGN

Yamaha Natural Sound stereo components are the pinnacle of audio component design. This is of course intentional; audio perfection is never accidental. Our C-Series Stereo Control Amplifiers and M-Series Stereo Power Amplifiers are the result of intensive research and an absolute commitment to quality. From the beginning, our goal was to invest them with unsurpassable performance, versatility, and reliability. We built them for those in search of uncompromising musical reproduction.

Dramatic technical innovations made famous in our digital musical instruments are further refined and incorporated into our C and M-Series amplifiers. It is then not surprising that they perform perfectly in tandem arrangements. The C-85 and M-85, for instance, will reproduce phono, cassette, and digital audio source signals with unprecedented power and clarity. Yamaha Zero Distortion Rule circuitry and Auto Class A Power achieve virtually distortion-free sound and ample peak power at all listening levels. Low-impedance multi-speaker drive capability, heavy-duty speaker terminals, and switchable LED power level meters assure reliable performance and operational

ease. Feature for feature, these components are a perfect combination.

Innovation in the Yamaha Tradition

The C-Series Stereo Control Amplifiers are a major breakthrough in audio technology. Regardless of the music source—phonograph, tape, digital audio, or video—the C-Series amplifiers deliver optimum audio fidelity. Zero Distortion Rule circuitry, ERE (Extended Rolloff Equalizer), Current Noise Suppression circuitry, and New Continuously Variable Loudness Control are innovations that really work.

Yamaha chose to develop the new C-Series amplifiers according to time-honored principles, and with the very latest technology. Given the amazing reproduction purity afforded by our Zero Distortion Rule, we devoted the same care to the most minute structural details. Even the input and Phones jack terminals are gold-plated.

Zero Distortion Rule

Zero Distortion Rule is incorporated in the phono EQ stages of each control amplifier presented here. It is also found in the MC

head amplifiers of the C-65 and C-85, providing the highest phono reproduction purity available in an audio amplifier.

Conceptually, Zero Distortion Rule is quite simple. As the name implies, it reproduces the input signal with total accuracy. This can only be achieved if the music signal waveform at the amplifier's output is identical to the music signal waveform at the amplifier's input. This is accomplished in a remarkably effective manner. Essentially, the Zero Distortion Rule system consists of the amplification stage, a detector circuit, and a summer. The distortion detector derives a signal from any and all distortion originating in the amplifier by "comparing" the shape of the input waveform to that of the output waveform. Any inconsistencies are perceived as a pure distortion signal. Since this system compares the input and output waveforms, all forms of distortion, i.e. non-linearity in transistors, capacitors, resistors, and all other circuit components, are detected. This "pure distortion signal" is isolated, inverted to a "negative distortion signal," and is fed back into the original audio/distortion signal by the summer. As the distortion signal reapplied to the amplifier's input is 180 degrees out of phase with the distortion occurring within the amplifier, the distortion is completely cancelled. This leaves the original audio signal distortion-free at the output stage. There is simply no more effective anti-distortion system available.

ERE (Extended Rolloff Equalizer)

Today's low-level, flat-response amplifiers achieve virtually distortion-free response up to more than 100 kHz. Conventional RIAA-standard equalizer amplifiers, however, cannot approach this level of performance. The Yamaha Extended Rolloff Equalizer meets this performance standard by eliminating phase

Basic ZDR Circuit Operation

The ZDR distortion detector separates the distortion components from the output audio signal and adds these back into the input signal out of phase, thereby cancelling the distortion.

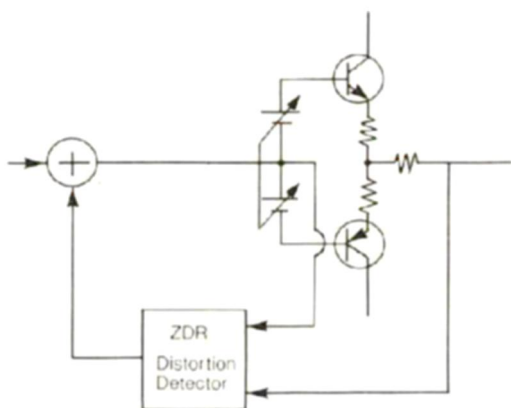

A: No ZDR applied.
Desired signal plus distortion waveform.

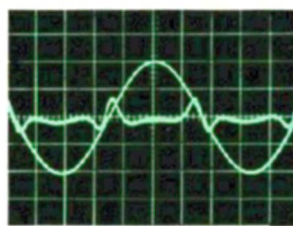

B: Normal application of ZDR.
Distortion waveform cancelled.

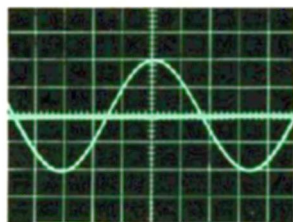

variation beyond the range where conventional equalizers begin to deviate from the RIAA curve. Due to high-frequency instabilities, this type of extended equalizer accuracy was previously impossible to attain. The Yamaha ERE eliminates this instability while providing an accurately extended high-frequency curve, permitting greater fidelity than before possible.

The Yamaha ERE circuit makes a significant difference in phono reproduction. It's a difference you'll appreciate when you rediscover the dynamics and nuance in your favorite recordings.

Extended Rolloff Equalizer and Current Noise Suppression Block Diagram

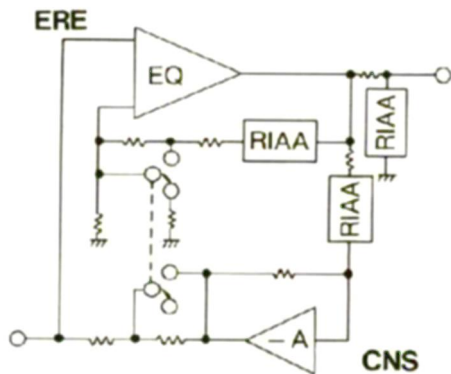

Current Noise Suppression Circuitry

When a phono cartridge is connected to the inputs of an amplifier, the interaction between the cartridge itself and the load presented by the amplifier generates "current noise." This means that an amplifier's phono input signal-to-noise performance will deteriorate when a cartridge is connected. The Yamaha Current Noise Suppression circuit incorporated in the phono EQ stages of the C-65 and C-85 minimizes current noise generation for an exceptionally high phono S/N ratio.

New Continuously Variable Loudness Control

The renowned Yamaha Continuously Variable Loudness Control compensates for the human ear's loss of low- and high-frequency sensitivity at reduced listening levels by attenuating the midrange frequencies accordingly. Unlike conventional On/Off loudness switches, the Yamaha control facilitates accurate subjective tonal response

New Continuously Variable Loudness Control Characteristics

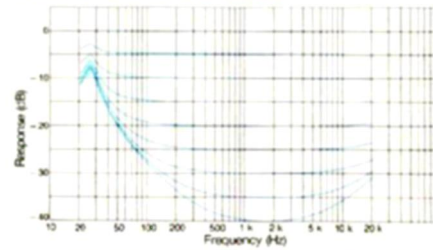

at any listening level. The New Continuously Variable Loudness Control covers a maximum range of 40 dB for use even at very high listening levels. Further, the level-related equalization curve employed in our new version has been redesigned to more accurately match the auditory characteristics of the human ear. This in turn results in the most natural response characteristics attainable.

4-Gang Volume Control

In most preamplifiers, the signal-to-noise ratio deteriorates as volume is reduced. This occurs when the amplifier's residual noise level becomes proportionately larger in relation to the reduced audio signal. Yamaha's four-gang volume control reduces the amplifier's residual noise as well as the audio signal level, and thereby maintains an extremely high signal-to-noise ratio all the way to the lowest listening level. No matter how low you set the volume, musical detail will not be obscured by unwanted noise.

Dual High/Low Power Supplies

The overall performance and broad dynamic range of our control amplifiers is greatly enhanced by the use of entirely separate power supplies for the low-level input stage and high-level output stage amplifiers. This results in outstanding power supply regulation and peak handling capacity. Most important, you'll experience the smooth musical reproduction available only in a Yamaha.

2-Band Parametric Equalizer

Parametric equalization is undoubtedly the most comprehensive means of tonal response tailoring available. Although it is a fairly recent development in the audio reproduction field, the parametric equalizer is found in every profes-

sional recording studio. The C-85 Stereo Control Amplifier features two-band parametric equalization for independently variable control over frequency, bandwidth, and level. That is, you can set any center frequency for a range of frequencies you wish to equalize; set the bandwidth to precisely cover the frequency range to be equalized; and precisely set the desired amount of boost or cut in the frequency range determined by the frequency and bandwidth settings.

Two bands of equalization are provided: one covers a frequency range from 31.5 Hz to 800 Hz; the other a frequency range from 800 Hz to 20 kHz. Parametric equalization provides continuously variable control over the width of each frequency band ($Q = 0.3$ to 3), and 12 dB boost/cut control in each band.

Parametric Equalizer Tone Control Characteristics (Level Control)

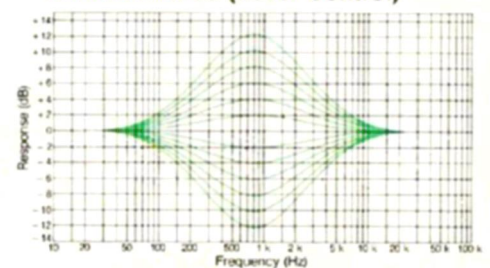

Tone Control Characteristics (Bandwidth Control)

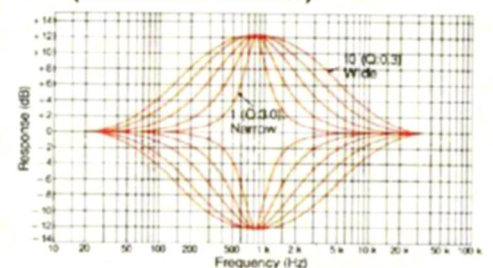

Tone Control Characteristics (Center Frequency Control)

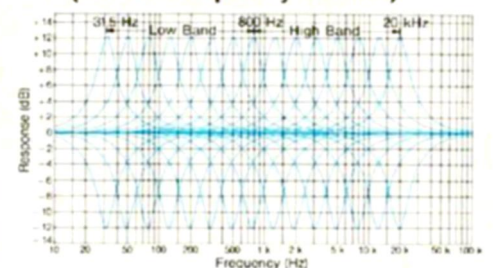

Optional EIA Standard Rack Mount Adaptors
(for C-85 and C-65)



THE PEAK OF AUDIO POWER AND PERFORMANCE

Yamaha's new M-Series Natural Sound Stereo Power Amplifiers offer an exciting blend of amplifier power and tonal purity. The incorporation of original Yamaha amplifier circuit innovations—Auto Class A Power and Zero Distortion Rule—are your assurance of unsurpassed audio performance. Auto Class A Power represents a significant breakthrough in amplifier circuit design, permitting pure Class A power amplification without power limitations or inefficient operation. Zero Distortion Rule, successfully introduced in recent Yamaha amplifiers, effectively eliminates all distortion in the power amplifier stage, making Auto Class A Power possible with absolutely no distortion by-products. Our new M-Series models offer peak performance in any listening environment.

Class A Versus Class AB Power

Class A power has long been the ideal in power amplification systems because of the reproduction purity it offers. Class AB power, however, has long been favored for its higher operating efficiency.

In a Class A circuit, the entire input signal waveform is amplified

continuously. In theory, the output signal will be identical to the original input signal. However, the transistors amplifying the input waveform are constantly "open," drawing large amounts of current even in the absence of a music signal. This places limits on the total output power that can be generated by a Class A circuit. It is also extremely inefficient, wasting large amounts of power in the form of dissipated heat. Despite the extreme reproduction purity offered by Class A power, these problems have prevented its widespread use as a power amplification system.

In a Class AB circuit, the input signal waveform is divided into its positive and negative waveform components. Separate transistors are employed to amplify these components independently. In a Class AB circuit, these transistors switch on and off continuously at the point where the signal waveform crosses from positive to negative, and vice versa. The two signals are recombined at the amplifier's output to form a composite music signal. Since the separate transistors amplify only half the input signal, and are switched off in the absence of a signal waveform or waveform component, Class AB operation is

extremely efficient. The inherent problems of Class AB circuitry, however, are switching distortion and crossover distortion induced into the signal as the transistors switch on and off. Switching distortion has been largely eliminated by biasing the transistors so they never shut off completely. Crossover distortion, however, cannot be completely eliminated in Class AB operation with conventional circuitry. Efficiency is achieved at the expense of tonal purity.

Auto Class A for Purity and Efficiency

Yamaha's new Auto Class A Power amplification system resolves the conflict between operating efficiency and reproduction purity. Extensive research has shown that with virtually all music sources—from hard rock to chamber music—almost 95% of the music signal requires low power, even at very high listening levels. High power is needed only for transient musical peaks. Pure Class A power, then, is suitable for all sources, and the efficiency of Class AB power is needed only for transient peaks.

In the Auto Class A power circuit, pure Class A power is provided for those portions of the music input signal that require average power levels (almost 95% of the source). When music peaks demand transient high power levels, operation is shifted to Class AB power for the duration of the transient peak, and ample power is applied to avoid clipping distortion. Zero Distortion Rule eliminates the problems of crossover distortion during Class AB operation. This also eliminates the problem of distortion arising from transistor non-linearity, a problem common to both Class A and Class AB power. The result is the amazingly pure sound reproduction of Class A operation, and sufficient power for high level peaks without the

Basic ZDR Circuit Operation

The ZDR distortion detector separates the distortion components from the output audio signal and adds these back into the input signal out of phase, thereby cancelling the distortion.

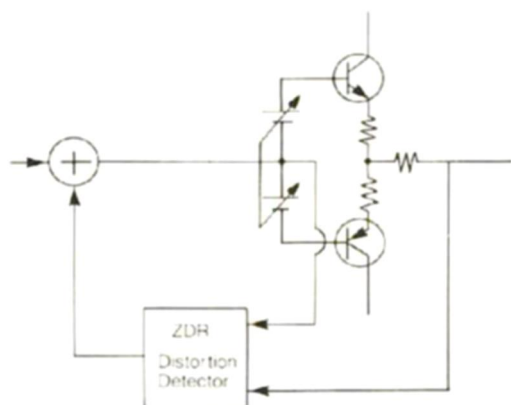

A. No ZDR applied
Desired signal plus distortion waveform.

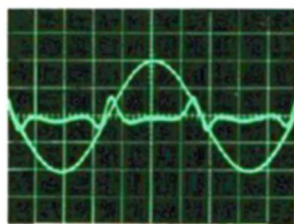

B: Normal application of ZDR.
Distortion waveform cancelled.

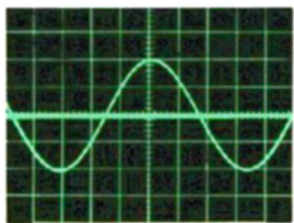

inherent distortion problems of conventional Class AB amplifiers.

Zero Distortion Rule Amplification: The Key to Clarity

Zero Distortion Rule amplification completely eliminates crossover and switching distortion problems inherent in conventional Class AB operation, thus making transient Class AB power within Auto Class A operation 100% pure and distortion-free. Further, Zero Distortion Rule eliminates distortion caused by semiconductor non-linearity with both Class A and Class AB operation. This results in exceptionally pure signal reproduction, and audibly superior imaging.

Switchable Wide Range Peak Hold LED Power Level Meters

20-segment LED power level meters are provided for an accurate display of how much power is actually being fed to your speakers. A load selector permits adjustment of meter readout to accurately match a 2, 4, or 8 ohm speaker load impedance. With the M-85, a Peak Hold function is provided so you can easily see the highest peak levels encountered in a program, and a 10x meter range function makes it easier to read low-power levels. Additionally, a Meter On/Off switch allows you to defeat the LED functions when desired.

Dynamic Power on Demand

The M-Series power amplifiers are capable of massive power output on demand. They will in fact exceed peak transient requirements at any listening level. High-capacity electrolytic capacitors and heavy-duty circuitry throughout provide fantastic power reserves, making them ideal for use with today's high-energy, dynamic digital audio sources.

Multi-Speaker, Low-Impedance Drive Capability

The M-Series components are carefully designed to drive a low-impedance load without danger of overload distortion or activation of protective shut-off circuitry. The M-85, M-65, and M-45 will each drive a 2-ohm load comfortably

Basic Operation of Class AB/A Output Stage

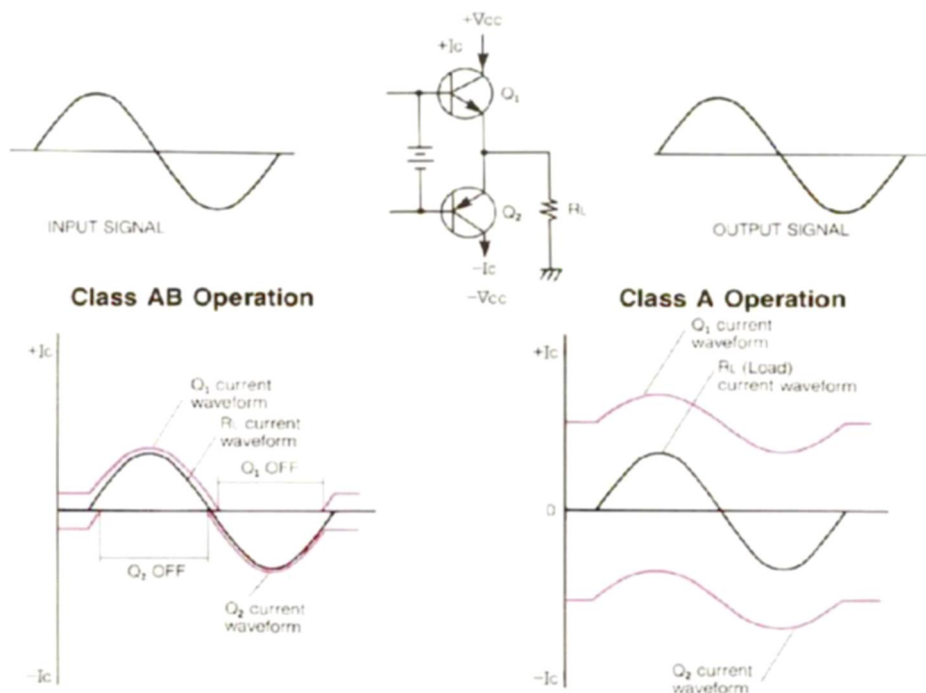

Actual Music Waveform Samples Showing Power Content

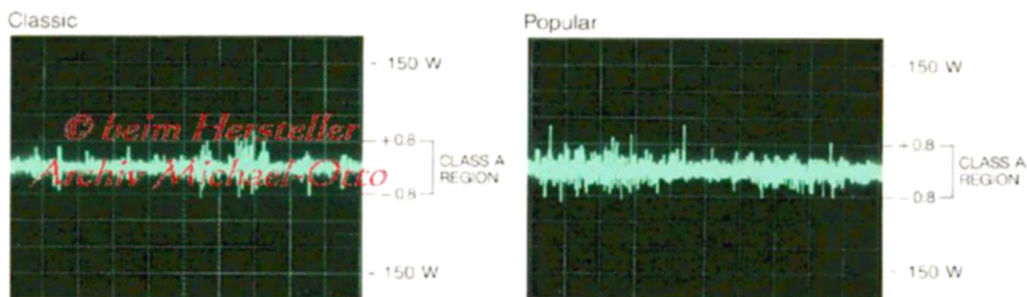

with plenty of dynamic power and not a trace of distortion, meeting the needs of audiophiles with low-impedance speakers or multiple speaker-pair systems.

Terminals and speaker selectors are provided to drive three pairs of speakers independently, simultaneously, or in any paired combination. Independent level controls for the left and right speakers also permit maximum power level setting for each speaker, making it possible to preset speaker balance for optimum stereo imaging within your listening environment.

Heavy-Duty Two-Way Speaker Connection Terminals

To ensure that every link in the audio system contributes to reproduction purity, many audiophiles prefer heavy-duty speaker cable for speaker connection. The M-85 and M-65 feature new, heavy-duty two-

way speaker connection terminals that make heavy-gauge cable connection fast and simple, without the need for twisting and soldering. Standard-gauge speaker wire can also be connected to the same terminal without adjustments.

Overload Protection Circuitry

Yamaha's M-Series power amplifiers are thoroughly protected against speaker overload, protecting both speakers and amplifier with automatic shut-off in the event of excessive power levels or speaker shorting.

Optional EIA Standard Rack Mount Adaptors (for M-85, M-65 and M-45)



VALUE WITH AN EMPHASIS ON PERFORMANCE

Step up to Yamaha quality with our new, refined C-45 Stereo Control Amplifier and M-45 Stereo Power Amplifier. Used in tandem, these outstanding components will reveal the power and nuance in your favorite recordings. With both you get reliable performance and convenient operation.

C-45 Natural Sound Stereo Control Amplifier

The C-45 offers stereo fidelity and control sophistication to meet the needs of today's demanding audiophile. An emphasis on vital performance features, notably our Extended Rolloff Equalizer in the phono stage, results in exceptionally pure reproduction. MM/MC

cartridge switching allows the use of both cartridge types without the need for a separate MC cartridge step-up transformer. A differential amplifier circuit is incorporated into the MC head amp and the MM equalizer sections for dramatically reduced distortion. Multiple audio source inputs, including five audio source inputs and an audio input for one video source, make this a versatile performer, too. The C-45's comprehensive tone control section has separate bass, treble, and mid-range frequency adjustments, a Tone Bypass function, a switchable subsonic filter, and our unique New Continuously Variable Loudness Control for superb clarity and presence at any listening level. A head-

phone amplifier is included for excellent reproduction using your favorite headphones.

M-45 Natural Sound Stereo Power Amplifier

The M-45 offers an exciting combination of brute power and tonal purity for the same low price as its predecessor, the M-40. Auto Class A Power and Zero Distortion Rule are at the heart of the M-45, which provides a substantial 125 watts of power per channel with an amazingly low 0.003% THD into 8 ohms. The M-45 is specially designed to deliver massive transient power output on demand, and will drive a low-impedance load without danger of overload distortion or activation

*© beim Hersteller
Archiv Michael-Otto*



of protective shut-off circuitry. Switchable LED power level meters, A-B speaker selector, heavy-duty speaker connection terminals, and two speaker-pair drive capability make the M-45 an ideal companion to the C-45 Stereo Control Amplifier.

M-45 Output Power vs. Speaker Impedance

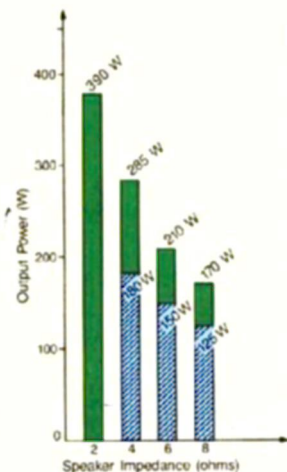

Tone Control Characteristics

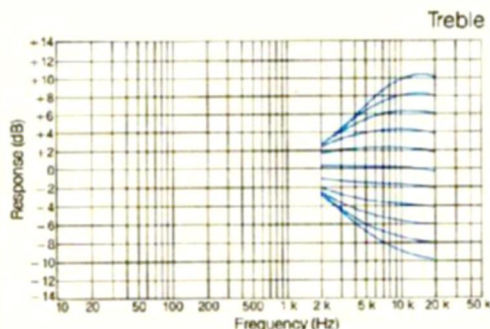
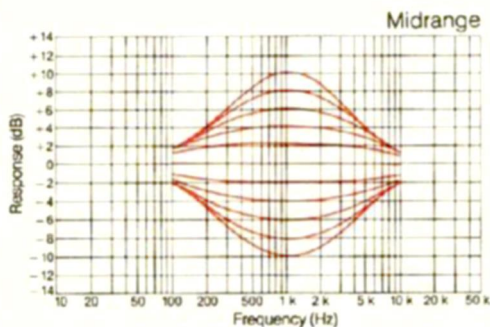
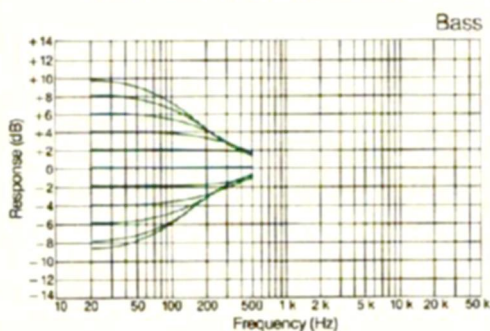

C-45 SPECIFICATIONS

Input Sensitivity/Impedance

Phono MC 100 μ V/100 ohms
 Phono MM 2.5 mV/47 k-ohms
 Video/Tape/Tuner 150 mV/47 k-ohms

Input Sensitivity (New IHF)

Phono MC 33 μ V
 Phono MM 0.83 mV
 Video/Tape/Tuner 50 mV

Maximum Input Level (1 kHz)

Phono MC (0.03% THD) 7 mV
 Phono MM (0.01% THD) 170 mV

Output Level/Impedance

Pre Out 1.5 V/47 ohms
 Rec Out 150 mV/330 ohms

Headphone Output Level/Impedance

(0.1% THD, 150 ohms) 4.2 V/82 ohms

Total Harmonic Distortion (3 V)

Phono MC to Rec Out 0.002%
 Phono MM to Pre Out 0.002%
 Video/Tape/Tuner to Pre Out 0.002%

Intermodulation Distortion

Video/Tape/Tuner, Rated Power,
 8 ohms 0.002%

Frequency Response (Tone Bypass On)

Video/Tape/Tuner
 20 to 20,000 Hz +0, -0.2 dB

RIAA Deviation

20 to 20,000 Hz
 (Phono MC/MM) ± 0.2 dB/ ± 0.3 dB
 10 to 100,000 Hz
 (Phono MM) ± 0.5 dB

20 to 100,000 Hz
 (Phono MC) ± 0.5 dB

Signal-to-Noise Ratio (IHF-A-Network)

Phono MC
 (500 μ V, Input Shorted) 84 dB
 Phono MM
 (5.0 mV, Input Shorted) 94 dB
 Video/Tape/Tuner
 (150 mV, Input Shorted) 106 dB

Signal-to-Noise Ratio (New IHF)

Phono MC 79 dB
 Phono MM 80 dB
 Video/Tape/Tuner 92 dB

Channel Separation (Vol. Max.)

Phono MC/MM, Input Shorted
 (40 Hz/1 kHz/10 kHz) 83/80/70 dB
 Video/Tape, 51 k-ohms
 (40 Hz/1 kHz/10 kHz) 82/68/48 dB

Tone Control Characteristics

Bass (boost/cut) ± 10 dB (20 Hz)
 Treble (boost/cut) ± 10 dB (20 kHz)
 Mid (boost/cut) ± 10 dB

Turnover Frequency

Bass/Treble 350 Hz/3.5 kHz

Filter Characteristics

Low (Subsonic) 15 Hz, -12 dB/oct

Power Consumption

30 W

Dimensions

(W x H x D) 435 x 83 x 298 mm
 (17-1/8" x 3-1/4" x 11-11/16")

Weight

4.2 kg (9 lbs. 4 oz.)

M-45 SPECIFICATIONS

Minimum RMS Output Power per Channel

(8 ohms) 125 Watts
 from 20 to 20,000 Hz at no more than
 0.003% Total Harmonic Distortion

(6 ohms) 150 Watts
 from 20 to 20,000 Hz at no more than
 0.007% Total Harmonic Distortion

(4 ohms) 180 Watts
 from 20 to 20,000 Hz at no more than
 0.02% Total Harmonic Distortion

Auto Class A Operating Range

(8 ohms) 5 W

Dynamic Power per Channel (1 kHz)

8 ohms 170 W

6 ohms 210 W

4 ohms 285 W

2 ohms 390 W

Dynamic Headroom

8 ohms 1.34 dB

6 ohms 1.46 dB

4 ohms 2.12 dB

Power Bandwidth (8 ohms, 0.03% THD)

Half Rated Power 10 to 60,000 Hz

Damping Factor (8 ohms, 1 kHz)

70

Input Sensitivity/Impedance

(Main In) 1.14 V/20 k-ohms

Frequency Response (Main In)

20 to 20,000 Hz +0, -0.3 dB

Signal-to-Noise Ratio (IHF-A-Network)

Input Shorted 123 dB

5.1 k-ohms 119 dB

Residual Noise (IHF-A-Network)

16 μ V

Total Harmonic Distortion

(8 ohms, Half Rated Power) 0.002%

Intermodulation Distortion

(8 ohms, Half Rated Power) 0.003%

Channel Separation (Input Shorted)

1 kHz/10 kHz 89 dB/70 dB

Power Consumption

U.S.A. 500 W

Canada 500 W/660 VA

Europe, U.K. and Australia 650 W

Other Areas 500 W

Dimensions

(W x H x D) 435 x 165 x 420 mm

(17-1/8" x 6-1/2" x 16-1/2")

Weight

12.5 kg (30 lbs. 13 oz.)

Specifications subject to change without notice.

THE HEART OF AN AUDIOPHILE SYSTEM



Our C-65 and M-65 models are designed for uncompromising performance. Match the incredible power of the M-65 Stereo Power Amplifier to the C-65's extensive control functions, and you have a pairing worthy of the most demanding audio enthusiast.

C-65 Natural Sound Stereo Control Amplifier

The C-65, like the C-45 and C-85, incorporates our most refined technology to deliver the ultimate in control amplifier performance. Yamaha's Zero Distortion Rule, DC Servo circuitry, and the Extended Rolloff Equalizer system are included in the phono EQ stage. The C-65

also utilizes Zero Distortion Rule circuitry in the MC head amplifier stage, resulting in exceptionally precise MC cartridge reproduction. This outstanding control amplifier features multiple audio source inputs, MM/MC cartridge load selector, continuously variable tone control turnover frequencies, backlit input selector indicators, and a subsonic filter.

Exhaustive attention to the critical elements of circuit design, componentry, and construction produce in the C-65 outstanding clarity and tonal quality.

M-65 Natural Sound Stereo Control Amplifier

The M-65 incorporates the

*© beim Hersteller
Archiv Michael-Otto*



technological advances featured in the M-45, including Auto Class A Power and Zero Distortion Rule circuitry. The M-65, however, offers even more power: an amazing 170 watts per channel with an unbelievably low 0.003% THD into an 8 ohm load. And, while most competitive models are built to drive no more than two speaker pairs, the M-65 will drive three pairs independently, simultaneously, or in any combination of two. It also provides the convenience of large LED power level meters and a meter display load selector. Like the M-45, the M-65 features huge dynamic power reserves, low-impedance drive capability, heavy-duty two-way connection terminals for up to three pairs of speakers, and full overload protection circuitry. For high-power performance in an audiophile component system, the M-65 is the ideal choice.

C-65 SPECIFICATIONS

Input Sensitivity/Impedance

| | |
|---------------------|---|
| Phono MC | 100 μ V/100 ohms |
| Phono MM | 2.5 mV/100 ohms, 47 k-ohms (220, 330 pF) |
| CD/Video/Tape/Tuner | 150 mV/47 k-ohms |

Input Sensitivity (New IHF)

| | |
|---------------------|------------|
| Phono MC | 33 μ V |
| Phono MM | 0.83 mV |
| CD/Video/Tape/Tuner | 50 mV |

Maximum Input Level

| | |
|----------|--------|
| Phono MC | 20 mV |
| Phono MM | 500 mV |

Output Level/Impedance

| | |
|---------|-----------------|
| Pre Out | 1.5 V/47 ohms |
| Rec Out | 150 mV/600 ohms |

Headphone Output Level/Impedance

| | |
|--------------------|--------------|
| (1 kHz, 0.01% THD) | 6 V/100 ohms |
|--------------------|--------------|

Total Harmonic Distortion (3 V)

| | |
|--------------------------------|--------|
| Phono MC to Rec Out | 0.002% |
| Phono MM to Pre Out | 0.001% |
| CD/Video/Tape/Tuner to Pre Out | 0.001% |

Intermodulation Distortion

| | |
|--|--------|
| CD/Video/Tape/Tuner, 5 V Output, Tone Bypass On | 0.002% |
|--|--------|

Frequency Response (Tone Bypass On)

| | |
|--|-------------|
| CD/Video/Tape/Tuner (20 to 20,000 Hz) | +0, -0.2 dB |
|--|-------------|

RIAA Deviation (Phono MC/MM)

| | |
|------------------|----------------------------|
| 20 to 20,000 Hz | ± 0.2 dB/ ± 0.2 dB |
| 10 to 100,000 Hz | ± 0.5 dB/ ± 0.5 dB |

Signal-to-Noise Ratio (IHF-A-Network)

| | |
|---|--------|
| Phono MC (500 μ V, Input Shorted) | 90 dB |
| Phono MM (5.0 mV, Input Shorted) | 95 dB |
| CD/Video/Tape/Tuner (150 mV, Input Shorted) | 106 dB |

Signal-to-Noise Ratio (New IHF)

| | |
|------------------|--------|
| Phono MC | 81 dB |
| Phono MM | 83 dB |
| Video/Tape/Tuner | 103 dB |

Channel Separation

| | |
|---|-------------|
| Phono MM, Input Shorted (40 Hz/1 kHz/10 kHz) | 85/80/70 dB |
| Video, Tape, 5.1 k-ohms (40 Hz/1 kHz/10 kHz) | 85/70/50 dB |

Tone Control Characteristics

| | |
|--------------------|-------------|
| Bass (boost/cut) | ± 10 dB |
| Treble (boost/cut) | ± 10 dB |

Turnover Frequency

| | |
|--------|---------------|
| Bass | 100 to 500 Hz |
| Treble | 1 to 5 kHz |

Filter Characteristics

| | |
|----------------|-------------------|
| Low (Subsonic) | 15 Hz, -12 dB/oct |
|----------------|-------------------|

Audio Muting

| | |
|--|--------|
| | -20 dB |
|--|--------|

Power Consumption

| | |
|--|------|
| | 30 W |
|--|------|

Dimensions

| | |
|-------------|-------------------|
| (W x H x D) | 435 x 95 x 380 mm |
|-------------|-------------------|

| | |
|--|--------------------------------|
| | (17-1/8" x 3-3/4" x 14-15/16") |
|--|--------------------------------|

| | |
|--------|------------------|
| Weight | 6.8 kg (15 lbs.) |
|--------|------------------|

M-65 SPECIFICATIONS

Minimum RMS Output Power per Channel

| | |
|--|-----------|
| (8 ohms) | 170 Watts |
| from 20 to 20,000 Hz at no more than 0.003% Total Harmonic Distortion | |

| | |
|--|-----------|
| (6 ohms) | 195 Watts |
| from 20 to 20,000 Hz at no more than 0.007% Total Harmonic Distortion | |

| | |
|---|-----------|
| (4 ohms) | 230 Watts |
| from 20 to 20,000 Hz at no more than 0.02% Total Harmonic Distortion | |

Auto Class A Operating Range

| | |
|----------|------|
| (8 ohms) | 20 W |
|----------|------|

Dynamic Power per Channel (1 kHz)

| | |
|--------|-------|
| 8 ohms | 255 W |
|--------|-------|

| | |
|--------|-------|
| 6 ohms | 315 W |
|--------|-------|

| | |
|--------|-------|
| 4 ohms | 380 W |
|--------|-------|

| | |
|--------|-------|
| 2 ohms | 450 W |
|--------|-------|

Dynamic Headroom

| | |
|--------|---------|
| 8 ohms | 1.76 dB |
|--------|---------|

| | |
|--------|---------|
| 6 ohms | 2.08 dB |
|--------|---------|

| | |
|--------|---------|
| 4 ohms | 2.18 dB |
|--------|---------|

Power Bandwidth (8 ohms)

| | |
|--------------------|-----------------|
| (Half Rated Power) | 10 to 60,000 Hz |
|--------------------|-----------------|

Damping Factor (8 ohms, 1 kHz)

| | |
|--|-----|
| | 130 |
|--|-----|

Input Sensitivity/Impedance

| | |
|-----------|------------------|
| (Main In) | 1.28 V/20 k-ohms |
|-----------|------------------|

Frequency Response (Main In)

| | |
|-------------------|-------------|
| (20 to 20,000 Hz) | +0, -0.3 dB |
|-------------------|-------------|

Signal-to-Noise Ratio (IHF-A-Network)

| | |
|---------------|--------|
| Input Shorted | 127 dB |
|---------------|--------|

| | |
|------------|--------|
| 5.1 k-ohms | 120 dB |
|------------|--------|

Residual Noise (IHF-A-Network)

| | |
|--|------------|
| | 16 μ V |
|--|------------|

Total Harmonic Distortion (Main In)

| | |
|----------------------------|--------|
| (8 ohms, Half Rated Power) | 0.002% |
|----------------------------|--------|

Intermodulation Distortion

| | |
|--|--------|
| Aux/Tape/Tuner (8 ohms, Half Rated Power) | 0.003% |
|--|--------|

Channel Separation (Input Shorted)

| | |
|--------------|-------------|
| 1 kHz/10 kHz | 89 dB/70 dB |
|--------------|-------------|

Power Consumption

| | |
|--------|--------------|
| U.S.A. | 520 W/680 VA |
|--------|--------------|

| | |
|--------|--------------|
| Canada | 650 W/800 VA |
|--------|--------------|

| | |
|----------------------|--------|
| Europe and Australia | 1150 W |
|----------------------|--------|

| | |
|-------------|-------|
| Other Areas | 520 W |
|-------------|-------|

Dimensions

| | |
|-------------|--------------------|
| (W x H x D) | 435 x 165 x 425 mm |
|-------------|--------------------|

| | |
|--|------------------------------|
| | (17-1/8" x 6-1/2" x 16-3/4") |
|--|------------------------------|

| | |
|--------|-----------------|
| Weight | 15 kg (33 lbs.) |
|--------|-----------------|

Specifications subject to change without notice.

M-65 Output Power vs. Speaker Impedance

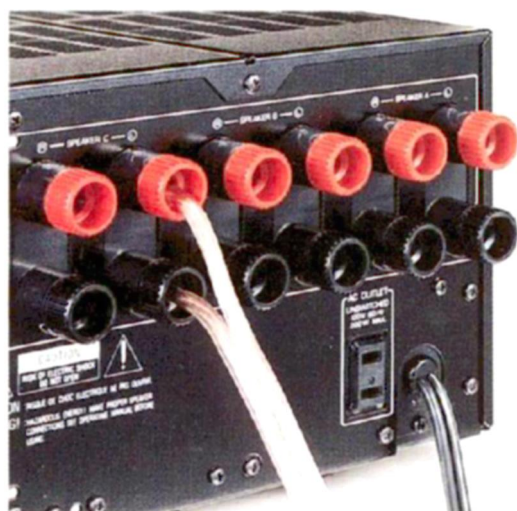
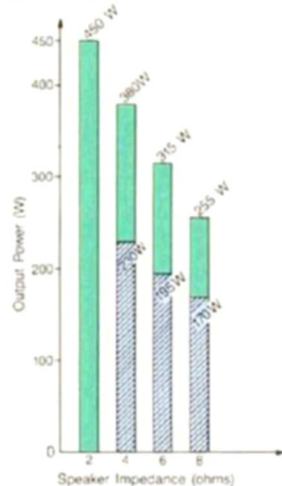

Heavy-Duty 2-Way Speaker Terminals

Only in a Yamaha

The reproduction of sound is a commitment that begins and ends with music. A challenge that is met not only in the laboratory, but in the recreation of human feeling and emotion that prove the ultimate test of music.

At Yamaha, we take the commitment seriously. It's why we're a specialist in contemporary technologies. We custom design and manufacture I.S.I.s that are the standard of quality for digital sound in electronic musical instruments and compact disc players alike. We develop new metals and synthetic materials that recreate the rich, acoustic properties of more traditional materials, meeting the stringent requirements of high-performance electronics. And we draw on the skills of quality craftsmanship acquired over a century of experience in making fine musical instruments to ensure a special standard of quality in both sound and styling. A standard of quality found only in a Yamaha.

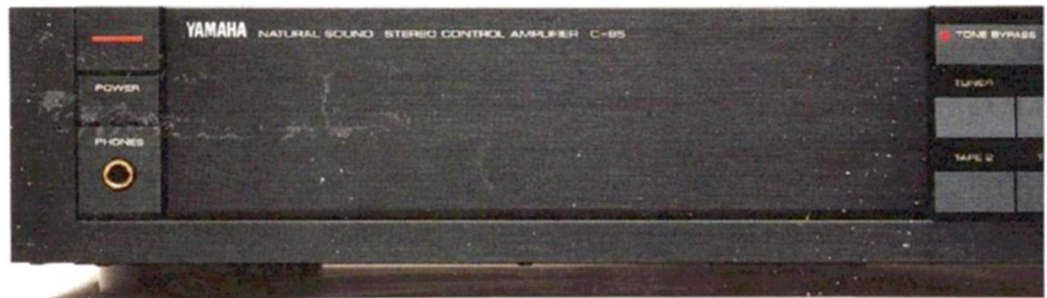

For details please contact:

SINCE 1887



YAMAHA

NIPPON GAKKI CO., LTD. HAMAMATSU, JAPAN