

dbx Model 165

INSTRUCTION MANUAL

dbx



Dear dbx customer:

Your new model 165A is identical to the old model 165 except for a special feature called PeakStop. Until a new manual is produced, this memo has all of the necessary PeakStop information and is intended to supplement the accompanying 165 manual.

The PeakStop feature allows you to control the maximum peak levels at the output of the 165A irrespective of any other control. PeakStop comes after the compression and other circuitry, including the output gain, so it lets an absolute limit be put on the peak-to-peak excursions of the output. PeakStop works instantaneously; you are able to apply moderate amounts of dbx's Over Easy compression and will still be protected from large transients, other short-term overloads, and overmodulation.

Technically, PeakStop consists of a sophisticated voltage-controlled clipper that produces a minimum of audible distortion. It rounds the corners of a peak rather than cutting it off sharply, as the word "clipping" usually implies. By making a signal's leading and trailing edges curved instead of sharp corners, it reduces the amount of higher odd-order, offensive-sounding harmonics that conventional clipping causes. The level at which PeakStop is activated is adjustable from -2 to +24 dBm. Note that small signal excursions above the set value of PeakStop are possible, to allow the rounding to take place; therefore, for any applications where you must not exceed a given ceiling, set the PeakStop control 1-2 dB below it to be sure.

The red PeakStop LED flashes whenever peaks attempt to exceed PeakStop level and get reduced in amplitude. To disable the PeakStop function altogether, simply set the control to +24 dBm (which is the maximum output level of the 165A anyway).

In use, the PeakStop function can prevent an amplifier from being driven into hard clipping, where it can lose control over the speaker system. PeakStop is a smooth, well-controlled clipper whose behavior is sonically similar to the gentleness of Over Easy compression; its clipping is much preferable to a power amp's. As mentioned, control of speaker overexcursion, broadcast overmodulation, and harsh electronics clipping are all applications of PeakStop. With it and Over Easy, you have the best of both worlds: virtually inaudible rms compression and peak protection downstream at the end.

Sincerely,

dbx Inc.
Professional Products

INDEX

BRIEF OPERATING INSTRUCTIONS	3
Front Panel	3
Rear Panel	4
INTRODUCTION	5
More About Separate Level Detector Access	5
More About Over Easy™ Compression	5
SIGNAL CONNECTIONS	6
Input Connection	6
Level Detector Input Connection	6
Output Connection	7
Grounding	7
Stereo Coupler Cable	7
Input Impedance & Terminations	7
OPERATION & APPLICATIONS	8
Compression Control	8
Threshold Adjustment & LED Indicators	8
Auto Switch & Auto Attack/Release LED Indicator	8
Attack Rate & Release Rate Controls	8
Where To Set Attack & Release Controls	8
Meter Calibration & Use	8
Use of an Equalizer in the Level Detector Circuit for Frequency Weighted Compression, De-essing, or Increasing Sustain	8
Use of a Filter in the Level Detector Circuit	9
Use of a Time Delay Line in the Signal Path but not in the Level Detector Circuit for Zero or Negative Attack & Release Times	9
The 165 As A Line Amplifier	9
SPECIFICATIONS	10
dbx PRODUCT WARRANTY & FACTORY SERVICE	10
BLOCK DIAGRAM	11
SCHEMATIC	12
dbx GLOSSARY	I

**WARNING: TO PREVENT FIRE OR SHOCK HAZARD,
DO NOT EXPOSE THIS APPLIANCE TO RAIN OR MOISTURE.**

BRIEF OPERATING INSTRUCTIONS

Fig. 1 – Front Panel

Threshold Indicators There are three LED's which indicate the relationship of the input signal level to the threshold of compression. The green LED is ON when the signal is below threshold, the red LED is ON when the signal is above threshold, and the amber LED is ON when the signal is in the Over Easy threshold range.* (Refer to Figure 4.) Since the LED's indicate the contents of the gain control signal, their response time will be affected by the selection of automatic or manual operation, and by the attack/release rates selected in manual operation.

NOTE: Even though no input signal is applied, it is normal for the Above Threshold and Over Easy™ LED indicators to flicker ON when the power is turned ON or OFF.

Power ON/OFF Switch Engage this switch to apply AC power to the unit. The LED (Light Emitting Diode) indicator above will be illuminated when the power is ON. No signal flows when the power is OFF, unless the System Bypass button is engaged.

Meter Function Switches These three interlocking pushbuttons determine whether the meter displays Input level, Output level or the amount of Gain Change. Input level metering is useful in deciding how much compression may be needed. Output level metering is useful as a check to ensure that the levels are not exceeding the desired maximum and the over-all gain of the 165 is set properly. Input and output levels are displayed on an RMS basis, with fixed time constants which are unaffected by the front panel attack and release controls. Gain change metering provides a more precise indication of how much of the program is being compressed than can be determined from the Threshold Indicator LED's. The meter, when displaying gain change, indicates the contents of the gain control signal, so its response time will be affected by the setting of the front panel manual/automatic switch and, in manual mode, by the attack and release rate controls. (Fixed gain changes commanded by the output gain control are not displayed by the meter's gain change function.)

Compression Control Clockwise rotation of this control increases the maximum amount of compression from 1:1 (unity gain) up to infinity. The unit can be considered to be a limiter at compression settings of 10:1 or higher, especially with a fast attack rate (above 100 dB/mS).

Auto Attack/Release Indicator This LED is illuminated when the 165 is in Auto Attack/Release mode.

Meter The meter is factory set so that 0 VU is equivalent to +4 dB input or output level, as selected with the Meter Function switch. The nominal 0 VU level may be changed to anywhere from -10 dB to +10 dB by adjusting the rear panel Meter Calibration trimmer. In Gain Change mode, the meter pointer moves down scale from 0 VU to indicate how many dB of compression the 165 is providing.

NOTE: The screw beneath the meter face is a zero-set adjustment to assure the needle rests at 0 VU when the unit is OFF; it is not intended for calibration. See page 8 for meter recalibration instructions.

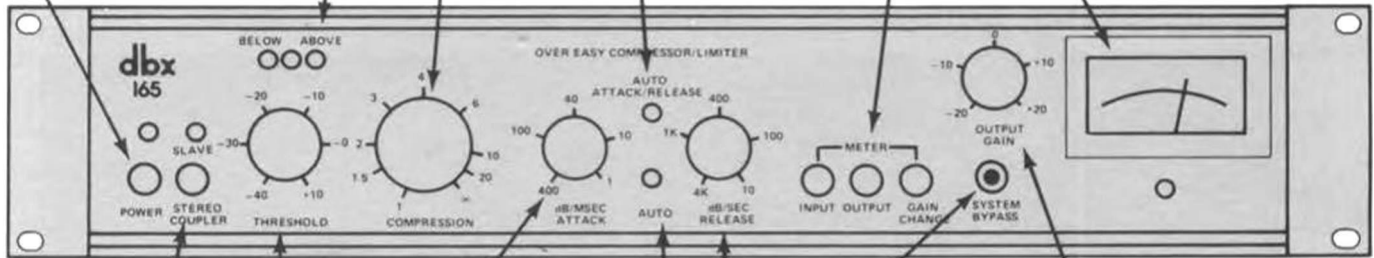

Stereo Coupler For single-channel (monaural) operation, this switch determines whether the unit will be the master (controlling unit) or the slave. The unit becomes a slave when the button is pressed IN, and the LED above the button turns ON to indicate the slave status. In stereo operation, all gain, attack/release, compression and threshold adjustments are made with the Master unit's controls. The Slave follows the Master's commands with the exceptions of Meter switching, System Bypass switching and Power switching which remain independent and must be done on both units.

Attack Rate Control Clockwise rotation of this control adjusts the maximum attack rate from 400 dB per millisecond to 1 dB per millisecond. The control setting only affects the 165's operation when the unit is in manual mode; it has no effect when the 165 is in Auto Attack/Release mode.

Auto Switch Engage this switch to place the 165 in the Auto Attack/Release mode. The compressor's attack rate and release rate then automatically vary to suit the volume envelope of the input signal. The attack and release characteristics may be set manually with the adjacent front panel controls when the switch is not engaged.

Threshold Control Adjust this knob to set the threshold of compression from -40 dB (7.8 mV) to +10 dB (2.45 V).** The threshold of compression is defined as the approximate middle of the Over Easy™ region.

Release Rate Control Clockwise rotation of this control adjusts the maximum release rate from 4,000 dB per second to 10 dB per second. The control setting only affects the 165's operation when the unit is in manual mode; it has no effect when the 165 is in Auto Attack/Release mode.

Output Gain Control This control adjusts the amount of gain in the 165's output amplifier stage. The signal can be attenuated or boosted by a full 20 dB relative to a "0" center setting (unity gain). This control is independent of the threshold of compression.

Because 20 dB of gain can be added at the 165 output, it is possible to cause clipping even when the input level is within the specified range. Especially when the COMPRESSION RATIO is set at a low number (a low "factor"), extreme clockwise rotation of the OUTPUT GAIN may cause the 165 output stage to clip program peaks. Therefore, for normal operation we suggest setting OUTPUT GAIN at "0 dB" (12 o'clock position). Where the circuit fed by the 165 has a high input sensitivity, lowering the 165's OUTPUT GAIN setting can avoid the need for an attenuation pad.

System Bypass Switch Engaging this button creates a hard-wired bypass of the 165's circuitry by connecting the input directly to the output. The Bypass is useful for A-B comparisons of the compressed and the "straight" program, or for rapid restoration of signal flow in the event of a 165 circuit problem.

NOTE: Since the system output is normally single-ended, in normal operation the (+) output carries the signal, while the (-) output is connected to ground. In the System Bypass mode, the (+) signal input is directly connected to the (+) signal output, and the (-) signal input is directly connected to the (-) system output. Thus, in Bypass mode, the output is single-ended when the input is single-ended, and balanced when the input connection is balanced.

**"Threshold" is defined as the point of 6 dB gain reduction when the unit is set for a maximum (infinite) compression ratio.
**0 dB is referenced to 0.775 V RMS.

Fig. 2 — Rear Panel

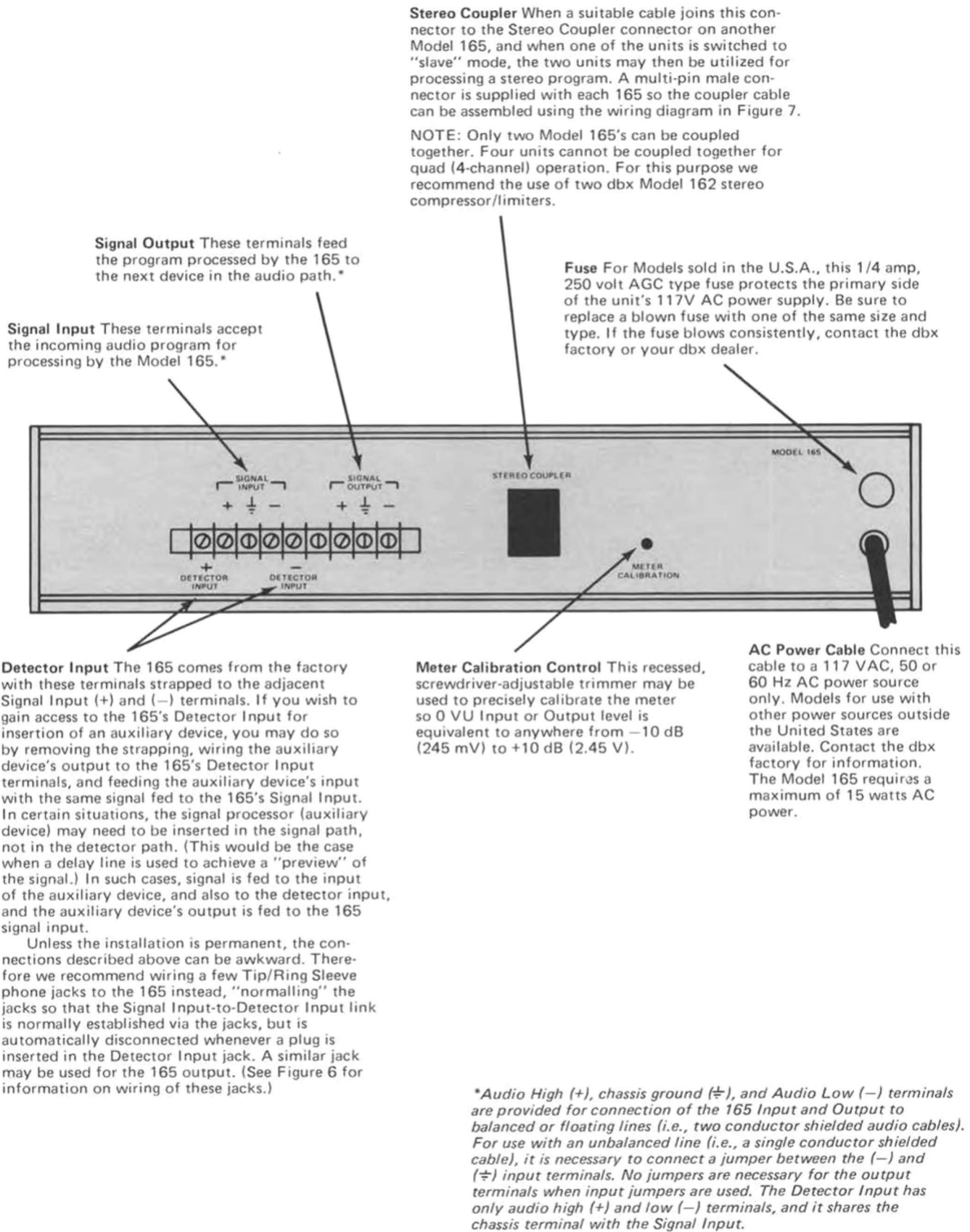

INTRODUCTION

The dbx Model 165 is a professional single channel compressor/limiter that features the new dbx Over Easy compression curve. The dbx Over Easy compression curve permits extremely smooth, almost inaudible compression due to the gradual change of compression ratio around the threshold, instead of the customary sharp threshold. This curve, plus dbx's true RMS level detector coupled to a wide-range voltage controlled amplifier in a feed-forward circuit, makes it possible to achieve larger amounts of compression without adverse audible side effects.

The RMS level detector is separately accessible, allowing various signal conditioners — equalizers, filters, delay lines, etc. — to be inserted in either the level detector or signal path independently. This feature aids in the compression of certain difficult types of material, as well as in the creation of special effects. In addition to dbx's automatically variable attack and release time circuitry (as on the Models 160, 161, 162, 163 and 164), a front panel switch and controls provide for manually adjustable attack and release rates over a very wide range.

The Model 165 also features stereo coupling for two 165's (at the touch of a front panel button), LED indicators showing whether the signal is at, above or below the threshold of compression, a 30 dB dynamic range meter (indicating input, output and gain change levels), and a rear panel zero VU calibration adjustment. A hard-wired bypass switch, also located on the front panel, is convenient for checking the effect of the compression, and assures failsafe flow of audio through the unit. The maximum input level is +24 dB (12.3 V RMS) and maximum output level is +23 dBm. The output amplifiers have a source impedance of 47 ohms and will drive input loads of 600 ohms or greater impedance. Output gain is also adjustable over a very wide range (± 20 dB), so the Model 165 is compatible with virtually all professional sound and creative audio equipment.

Perhaps the most flexible and useful compressor/

limiter ever offered, the dbx Model 165 is well suited to a wide range of applications including: tape recording, disc mastering, radio and TV production and broadcast, live concert sound reinforcement, and theatrical production.

More About Separate Level Detector Access

Because auxiliary sound equipment can be used to process the level detector signal but not the main audio input signal (or vice-versa), the 165 offers the user an opportunity to create many unusual effects. By connecting it to additional signal processors, such as a parametric equalizer, the Model 165 can be converted to a de-esser, a vocal stresser or a level-sensitive filter. Certain musical or vocal elements in a program can be suppressed without affecting others. In addition to these signal conditioning functions, many creative special effects are possible.

More About Over Easy Compression

Conventional compressor/limiters have a sharp knee at the threshold point (see Figure 3A). That is, when the input signal is below the threshold, the gain remains fixed (1:1 ratio or no compression), but when the input signal goes above the threshold, the gain abruptly decreases according to the compression ratio for which the unit is adjusted (several fixed compression ratios are shown in Figure 3A). This abrupt change in gain in a conventional compressor/limiter is often audible and therefore undesirable to the user.

The dbx Over Easy approach utilizes a soft knee at the threshold of compression (see Figure 3B). The Over Easy compressor/limiter gradually increases its compression ratio from 1:1 towards the set compression ratio as the input signal rises through the threshold region. Thus an age old dream can be realized . . . dynamic range restriction without audible, abrupt gain changes. When properly operated, the Model 165 is a highly effective compressor/limiter that you don't hear working.

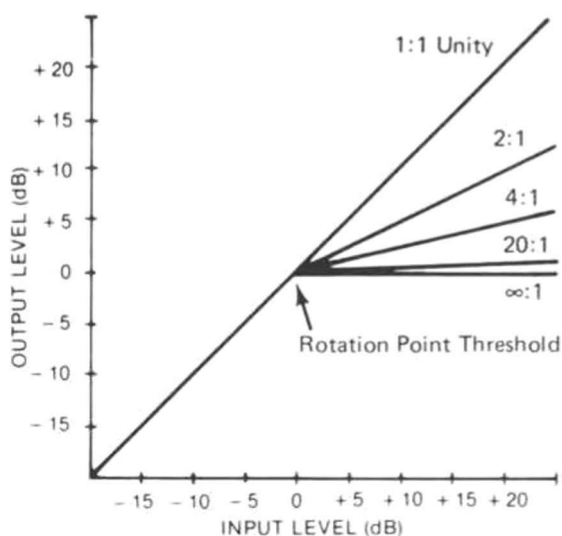

3A — Conventional Compressor/Limiter

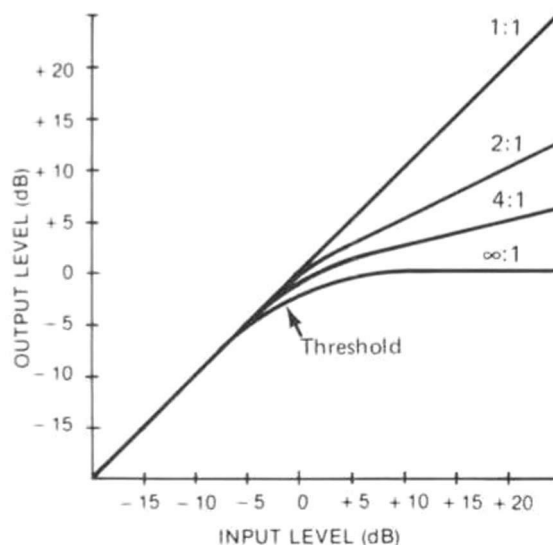

3B — Over Easy Compressor/Limiter

Fig. 3 — Over Easy™ Versus Conventional Compression

SIGNAL CONNECTIONS

Since dbx Over Easy compressor/limiters have no distinct point at which the gain changes, the threshold on such units is defined differently from conventional units. We define the threshold to occur approximately mid way between the fixed gain portion of the curve and the point where the curve "levels off" at the selected compression ratio. At an infinite compression setting, threshold is defined as the level at which 6 dB gain reduction is realized. At this setting, the maximum permissible output level is 5 dB above the threshold. At lower compression settings, the threshold represents somewhat less gain reduction. (In contrast, a conventional compressor/limiter yields 0 dB of gain reduction at the threshold; gain reduction begins just above the threshold.) To see how the 165's Threshold indicator LEDs correlate with the compression curves, refer to Figure 4.

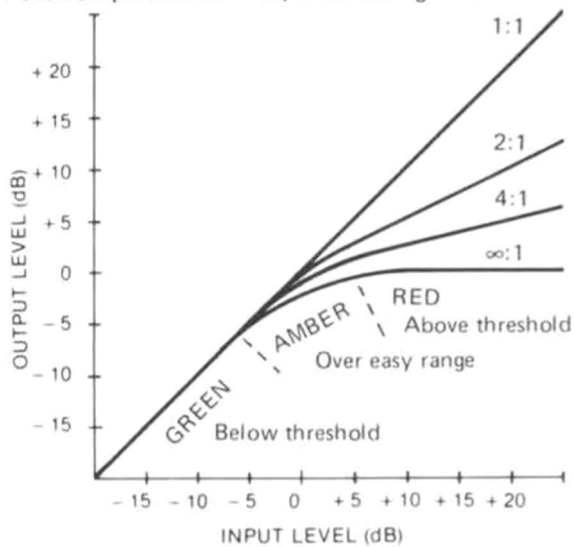

Fig. 4 — How The 165 Threshold Indicator LED's Correlate With The Compression Curve

Make input and output connections to the barrier strip on the rear panel (Figures 5 and 6).

Input Connection

For balanced or floating lines, connect the signal leads to the (+) and (-) terminals, and the shield to the chassis ground (\varnothing) terminal. For unbalanced lines, connect the signal high lead to the (+) terminal, and jumper the (-) and chassis ground (\varnothing) together for connection of the shield. When using an unbalanced connection, reversing the (+) and (-) input terminals will cause the output signal to be 180° out of phase (reverse polarity) relative to the input signal.

Level Detector Input Connection

For normal compressor operation, leave the factory-installed straps connected between the Detector (+) and the Input Signal (+) terminals and the Detector (-) and Input Signal (-) terminals. (Refer to Figure 5.) If you wish to gain access to the 165's Detector Input for insertion of an auxiliary device, you may do so by removing the strapping, wiring the auxiliary device's output to the 165's Detector Input terminals, and feeding the auxiliary device's input with the same signal fed to the 165's Signal Input. In certain situations, the auxiliary device may need to be inserted in the signal path, not in the detector path. In such cases, signal is fed to the input of that device, and also to the detector input, and the auxiliary device's output is fed to the 165 signal input. Unless the installation is permanent, this connection can be awkward. Therefore, we recommend wiring a few Tip/Ring/Sleeve phone jacks to the 165 instead, and using the jacks for Signal and Detector Inputs as well as for the Signal Output. (Refer to Figure 6.)

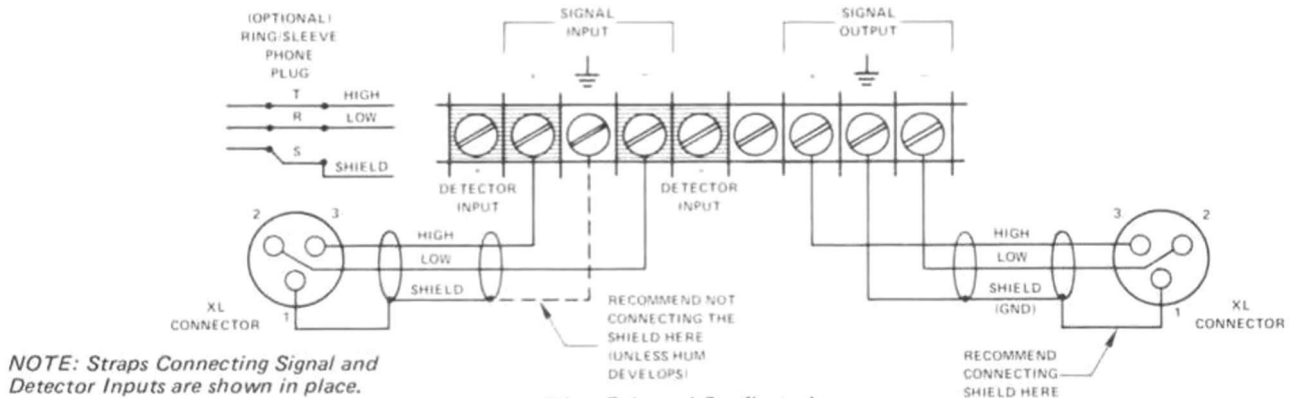

5A — Balanced Configuration

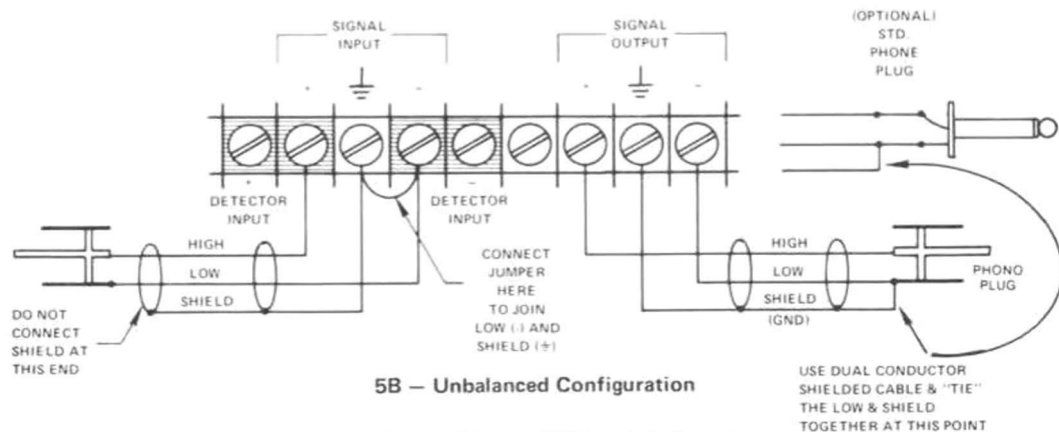

5B — Unbalanced Configuration

Fig. 5 — Typical Signal Connections to 165 Input & Output

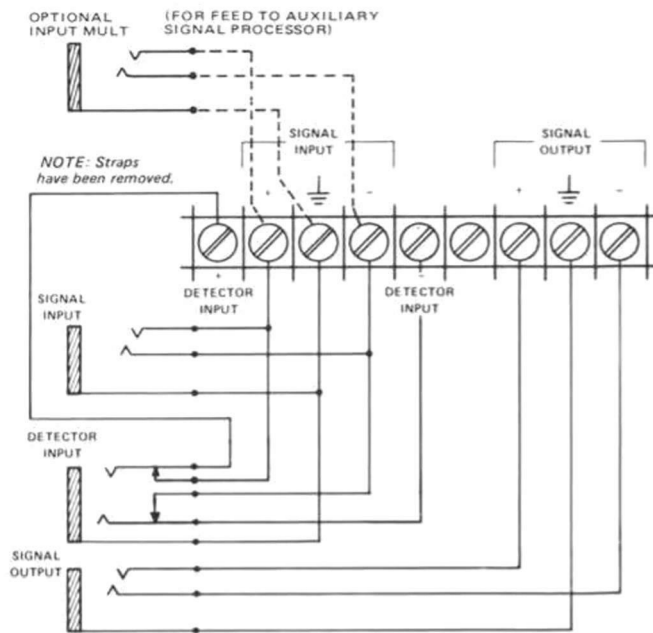

Fig. 6 – Signal Input & Output Jacks With A Normalling Jack For The Detector Input Dotted lines indicate location of optional mult jack (parallel wired) for feeding input of auxiliary device with same program as 165 Signal Input.

Output Connection

The output of the dbx 165 is designed to feed balanced or unbalanced 600 ohm or greater loads. The output stage is single ended, so that in normal operation, the (–) signal output terminal is internally connected to the (\neq) terminal. When the system bypass switch is engaged, the signal inputs are directly connected to the signal outputs (so a balanced input would produce a balanced output).

Grounding

For maximum hum rejection, avoid common grounding at the input and output (i.e., double grounding). One method that usually works is to ground the shield at the 165's output Ground (\neq) terminal and also ground it at the input of the following device. Do not connect the shield at the 165's input Ground terminal; leave the input shield connected only to the output of the device feeding the 165.

Stereo Coupler Cable

When you wish to link two Model 165's for processing a stereo program, a cable must be constructed to join the Stereo Coupler connectors on the two units. Use the mating connectors supplied with each Model 165, and wire the cable according to Figure 7. Use connectors supplied with units, or equivalent (Cinch-Jones P-312–CCT). The cable should be 6-pair, twisted 24 ga. wire with shield (Belden 9506).

Once the cable is connected to the two 165's, it may be left in place at all times. When both units' Stereo Coupler switches are placed in "master" mode (button OUT), the 165's operate completely independently; stereo operation is achieved simply by switching one of the two units to "slave" mode (button IN, Slave LED ON).

Input Impedance & Terminations

There is sometimes a misunderstanding regarding the nature of matching and bridging inputs, the use of terminating resistors, and the relationship between actual input impedance and nominal source impedance. Most electronic outputs work well when "terminated"

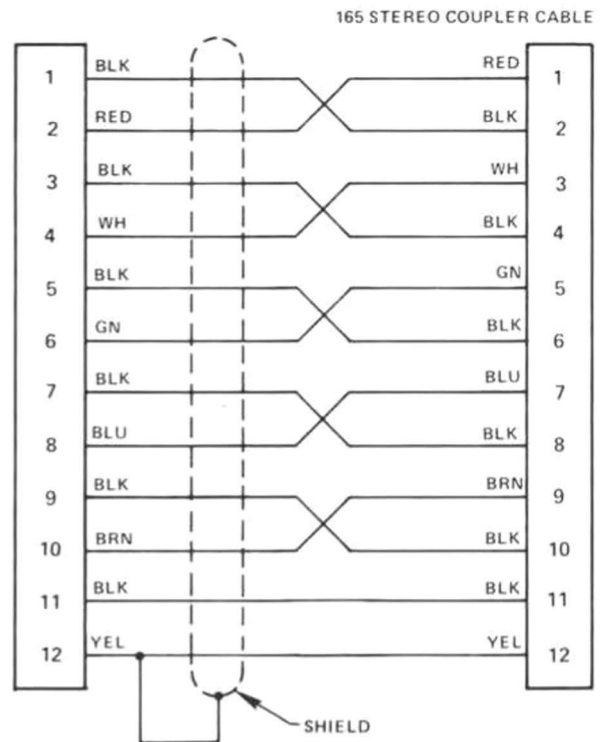

Fig. 7 – Stereo Coupler Cable

NOTE: The cable for the dbx Model 162 is not compatible with the Model 165.

by an input (connected to an input) having the same or a higher actual impedance. Outputs are usually overloaded when terminated by an impedance that is lower than the source impedance. When the input impedance is nearly the same impedance as the source, it is known as a "matching" input. When an input is 10 times the source impedance, or more, the input is considered to be a "bridging" input.

The dbx Model 165 signal input has an actual impedance of 22,000 ohms in balanced configuration or 11,000 ohms in unbalanced (it has a high-Z* input). This makes the 165 signal input suitable for use with virtually any nominal source impedance, low or high. The dbx signal input will bridge 150-ohm or 600-ohm (low-Z) lines.

The dbx 165 detector input has an actual impedance of 600,000 ohms in balanced configuration or 300,000 ohms unbalanced. This very high impedance means the level detector will bridge virtually any nominal source impedance. It also means that when the jumper connectors link the detector and signal inputs, the detector has a negligible effect on the 165's input impedance as "seen" by the source device. The very high impedance of the detector does suggest, however, that cables from an external processor to the detector input be kept as short as practical to reduce susceptibility to hum and RFI.

Terminating resistors are not needed for the dbx 165 signal or detector inputs to operate correctly, but may be required at these inputs when they are fed from devices (such as passive equalizers) designed for a specified load impedance.

The dbx 165 output is capable of driving loads of 600 ohms or greater. While it may be terminated by a low impedance, such termination is not required.

*"Z" is an abbreviation for "impedance."

OPERATION & APPLICATIONS

Additional Information on the Setting and Function of Certain Controls.

Compression Control

This control is continuously adjustable from a compression ratio of 1:1 to infinite compression (that is, no change in output level regardless of changes in input level above the set threshold). High compression (settings greater than 6) significantly level out program materials. Infinite compression virtually stops music levels from exceeding the threshold setting. Lower compression settings (below 4) still permit dynamic range to exist. They are used to tighten up the sound of a bass guitar, lead guitar, snare drum, kick drum and vocals. Moderate overall compression is typically used during stereo mixdowns. Here a variety of settings could be used.

While any compression ratio can be set with this control, remember that the Over Easy curve causes that ratio to be approached gradually as the input signal level rises through the threshold. Only when the input signal is considerably above the threshold does the 165 closely approach the set ratio of compression. (See Figure 3.)

Threshold Adjustment & LED Indicators

The Threshold control sets the level at which the 165 begins to compress the signal (i.e., it sets the point where the Over Easy compression curve intersects the input signal). The control has a wide range so that the desired results can be obtained with any line level input signal. When the Threshold control is set too low, the 165 will compress most if not all of the input signal (red LED ON most of the time). At low compression ratios, the very low threshold setting can be used to gently reduce the overall dynamic range of the program. Low threshold settings (-20 to -40) are used when program materials are to be compressed. Low settings, with high input levels, cause the 165 to "work" all or more of the time than with lower input levels. The major portion of program material *is processed* with a low threshold setting. Normal compression and "leveling" of vocals and instruments typically use lower settings. Compression of the whole program, however, may not sound natural, especially at compression ratios of 10:1 or greater. High threshold settings (-10 to +10) are used for limiting program levels or where only peaks are to be compressed. The major portion of the program material *is not processed* with a high threshold setting. Speaker protection and peak overload prevention are just two applications.

NOTE: Whenever threshold level and compression ratio settings are made, it is important to watch the LED's and meter for reference and confirmation. Remember that a compressor/limiter is a tool that can provide desirable effects when used properly. When used to excess, the results can sound unusual, and may be of value only for special effects.

With the Compression control set for the desired maximum compression ratio (or an approximation thereof), rotate the Threshold control counterclockwise until the desired sound, special effect, or amount of gain reduction is achieved.

Auto Switch & Auto Attack/Release LED Indicator

When the Auto switch is IN (Auto Mode), the LED indicator will be illuminated and the Model 165 will automatically adjust its attack rate and release time to suit the program envelope. (This Auto Mode sets the Model 165 for the same attack and release characteristics as dbx Models 160, 161, 162, 163 and 164 compressor/

limiters.) When the Auto switch is OUT (manual mode), the LED indicator above it turns OFF, and the front panel Attack and Release rate controls determine the maximum rate of gain change and the behavior of the level detector circuitry (see below).

Attack Rate & Release Rate Controls

The Model 165 is the first dbx compressor/limiter to offer a choice of automatic or user adjustable attack and release characteristics. In Auto Mode, the 165 utilizes the patented dbx RMS level detector with its program dependent attack/release characteristics to obtain natural-sounding compression or limiting. For special effects and certain signal situations, however, it is often desirable to set fixed attack and release characteristics. Manual mode affords this capability. The Auto Mode is recommended for vocals as well as instruments. When determining separate attack and release rate control settings, it provides a good starting point. Because the Auto Mode has a variable attack rate, the 165 may compress or limit some program materials smoother than in the manual mode which has a fixed rate of attack. This is especially true on vocals.

Where To Set Attack & Release Controls

There is no "right" way to set the Attack and Release controls. Generally, one would want a slow enough Release to avoid "pumping" or "breathing" sounds caused when background sounds are audibly modulated by the dominant signal energy, yet the release must be fast enough to avoid suppression of the desired signal after a sudden transient or a loud note has decayed. Depending on the desired effect, one might want a very slow Attack so that percussive or transient sounds are not restricted, but average volume levels are held within the desired range.

A very fast attack setting (control maximum counterclockwise) will cause the 165 to act like a peak limiter even though RMS detection circuitry is used. Slower attack settings cause the 165 to act like an RMS or averaging detecting compressor/limiter. Don't forget, attack and release controls operate together and with the compression ratio control. Changing any one control may necessitate changing the other settings.

Meter Calibration & Use

The meter in the 165 is factory calibrated to indicate "0" when the signal level is +4 dB (1.23 V) at either the input or output of the 165, depending on the meter function switch position. (When the meter is in Gain Change mode, "0" indicates no gain change; the meter calibration control does not affect this mode.)

To recalibrate the meter, engage the Input meter function switch and feed a 1 kHz signal at the selected nominal operating level (the level desired for a "0 VU" meter indication) to the 165's signal input. Then adjust the rear panel METER CALIBRATION control until the meter indicates "0 dB".

Use of an Equalizer in the Level Detector Circuit for Frequency Weighted Compression, De-essing, or Increasing Sustain

It is possible to "separate" certain instruments from a mix by frequency weighted compression. This function is created by inserting an equalizer ahead of the Model 165's level detector input, but not in the main signal input path. Peaking the equalizer in a certain frequency range will tend to suppress any frequencies (notes) in that register. A relatively high threshold setting can allow normal sounds to be unaffected while solo or very

loud sounds are held back. Of course, when compression does occur, the level of the entire program is affected. For this reason, it may be more useful to reserve this combined EQ/compression technique for isolated sound sources, such as a single channel of vocal or a single instrument in a multi-track program. Unlike overall program equalization, EQ of the level detector will take effect only when signals are above threshold (or when those frequencies affected fall above the set threshold). Depending on the threshold setting, lower-level fundamentals or harmonics will not cause compression, and the program is not subject to the phase shift normally caused by program equalization.

For example, consider a single channel carrying the preamplified signal from a microphone placed near a cymbal and a tom-tom. Set up the 165 with an equalizer in the level detector path, as depicted in Figure 8. The equalizer can be adjusted for boost with a peak at about 5 kHz, causing the cymbal to be compressed on a very loud crash, preventing tape saturation at high frequencies where there is less headroom. However, gentle tapping of a drumstick or brushing of the cymbal will not be held back. Assuming the tom-tom is a lower frequency instrument, and can be better tolerated by the tape, there is less need for compression on it. The equalization in the detector circuit means that the compressor will not be triggered as readily by a loud tom beat as by an equally loud cymbal crash.

Another application for this type of EQ boost in the level detector is for increasing the sustain of a guitar, bass, etc; this requires EQ boost in the dominant frequency range of the instrument, along with a fairly low threshold and a moderate compression ratio.

Still another related application involves de-essing of vocals (reduction of sibilance). Use a parametric equalizer in the level detector circuit and set it for high frequency boost in the specific frequency range where the vocal "hiss" or lisp occurs. This pre-emphasizes the already "hissy" vocal input to the detector. Used in conjunction with a moderate to high threshold and compression ratio, this arrangement greatly attenuates the "essing" without affecting the basic sound quality or balance of the voice. While it is true that all frequencies are lowered in level when the compressor is triggered, generally the "sss" sound occurs alone, before or after the dominant tone in the voice. (If this seems unlikely, just try to hum and hiss at the same time.)

The converse of the above EQ techniques may be used; dipping the equalizer will cause any sound in the affected register to pull the level up because it will seem to require less compression than the other frequencies.

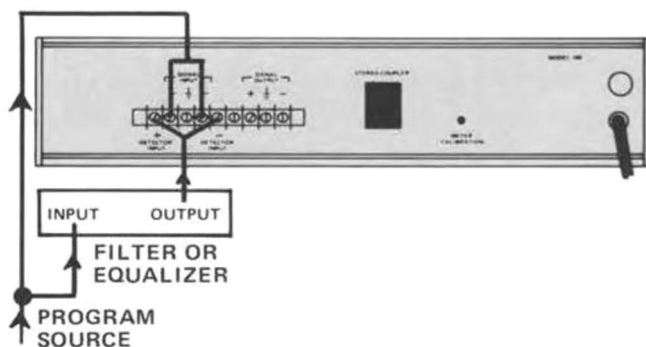

Fig. 8 – Equalizer or Filter Used with the Level Detector Input

Use of a Filter in the Level Detector Circuit

The results of inserting a filter in the level detector circuit are basically the same as obtained with an equalizer, as previously described. Those frequencies passed by the filter are subject to compression (or at least they are subject to considerably more compression than those frequencies outside the passband). Because a passive filter can have insertion loss, it may be necessary to lower the 165's Threshold setting to maintain a given amount of gain reduction within the filter passband; this can be determined, as usual, by monitoring the 165's threshold indicator LEDs.

Use of a Time Delay Line in the Signal Path but not in the Level Detector Circuit for Zero or Negative Attack & Release Times

While the Model 165 can be set for incredibly fast attack times, there will always be some small transient that "gets past" the level detector. In some cases — such as maximum modulation broadcasting — it may be desirable to preserve the sonic quality obtained with a slower attack time, yet it may not be permissible for even the slightest overshoot to get past the compressor/limiter. A delay line (digital or analog) can be used in this instance. By feeding the program directly to the 165's detector input, but delaying the feed to the 165's signal input, the unit can "anticipate" the need for a gain change. (Refer to Figure 9.) With some experimentation, the effect can be that of "zero" attack time.

Additional signal delays beyond the "zero" time established above would then cause the compressor to finish changing gain before the leading edge of the loud passage enters the signal input, suppressing program which is not above threshold. Also, the 165 would begin to recover from compression (release) before the input signal has dropped back to the set threshold, causing the output to surge higher in level as the note or passage is decaying. This special effect obtained with the time delay might sound akin to reverse playback of a tape recording.

Access to the 165's level detector makes possible a whole range of effects not normally available. The more you think about it and experiment, the more useful this capability can become.

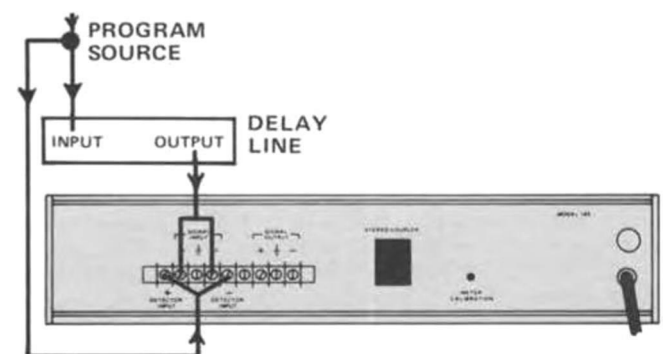

Fig. 9 – Delay Line Used With The Signal Input

The 165 As A Line Amplifier

To use the 165 as a line amplifier, adjust the COMPRESSION RATIO control to fully counterclockwise (1:1 position), THRESHOLD to full clockwise position (+10) and OUTPUT GAIN to whatever setting is required for the application. Remember that, as with any amplifier, excessive gain may lead to output clipping of high level signals. To add compression, adjust the COMPRESSION RATIO and the THRESHOLD controls to the desired settings.

SPECIFICATIONS

Input Characteristics

IMPEDANCE

Signal: 22 kohms, balanced; 11 kohms, unbalanced
Detector: 600 kohms, balanced; 300 kohms, unbalanced

LEVEL

Signal: > +24 dB (12.3 V) maximum
Detector: > +28 dB (18.6 V) maximum

Output Characteristics

IMPEDANCE

Less than 47 ohms (active low Z output)

LEVEL

> +23 dBm (11 V) into a 600 ohm or higher Z termination

Performance Characteristics

DISTORTION

2nd harmonic, 0.05%
3rd harmonic, 0.2% (Auto or Manual with Attack & Release Controls Centered)

NOTE: Distortion figures are typical at infinite compression, 1 kHz, 0 dBm (0.775 V) input and output. 2nd harmonic is relatively unaffected by compression ratio, time constants and frequency while 3rd harmonic decreases with slower time constants, higher frequency and lower compression ratio.

EQUIVALENT INPUT NOISE

Less than -90dBm, 20 Hz to 20 kHz

ATTACK RATE* (63% dB reduction in Signal Level)

Auto Mode: 15 mS for 10 dB level change, 5 mS for 20 dB level change, 3 mS for 30 dB level change

Manual Mode: Continuously variable from 1 to 400 dB per millisecond.

RELEASE RATE*

Auto Mode: 120 dB/second

Manual Mode: Continuously variable from 10 to 4000 dB per second.

FREQUENCY RESPONSE

+0, -1 dB from 20 Hz to 20 kHz

Controls

THRESHOLD

Continuously variable from -40 dB (7.8 mV) to +10 dB (2.45 V)

COMPRESSION RATIO

Continuously variable from 1:1 to infinity:1

ATTACK RATE

Continuously variable from 400 dB per millisecond to 1 dB per millisecond

RELEASE RATE

Continuously variable from 4,000 dB per second to 10 dB per second

OUTPUT GAIN

Continuously variable from -20 dB to +20 dB

Metering

RANGE

30 dB (from -20 to +10 VU)

FUNCTION

Switchable for input level, output level or gain change

CALIBRATION

Factory preset at 0 VU = +4 dB (1.23 V); rear panel potentiometer sets 0 VU for any level from -10 dB (7.8 mV) to +10 dB (2.45 V).

Connectors

SIGNAL

Jones type barrier strip for signal input, signal output, and detector input.

STEREO COUPLER

12 pin Cinch-Jones J-312-CCT connector for strapping two 165's together to process a stereo program.

General

POWER REQUIREMENTS

117 V AC \pm 10%, 50 or 60 Hz; 234 V AC, 50 or 60 Hz available on special order for use outside the U.S.

DIMENSIONS

19" wide x 3-1/2" high x 10-1/8" deep
(48.3 cm x 8.9 cm x 25.7 cm); suitable for rack mounting

NET WEIGHT

8 Pounds (3.6 kg)

*Measured in the infinite compression region of the over easy curve.

dbx PRODUCT WARRANTY & FACTORY SERVICE

All dbx products are covered by a limited warranty. Consult your warranty card or your local dealer for full details.

The dbx Customer Service Department is prepared to give additional assistance in the use of this product. All questions regarding interfacing dbx equipment with your system, service information or information on special applications will be answered. You may call during normal business hours — Telephone: 617-964-3210, Telex: 92-2522, or write to:

dbx, Inc.
71 Chapel Street
Newton, MA 02195
Attn: Customer Service Department

Should it become necessary to have your equipment factory serviced:

1. Please repack the unit, including a note describing the problem along with the day, month and year of purchase.

2. Send the unit freight prepaid to:

dbx, Inc.
224 Calvary Street
Waltham, MA 02154
Attn: Repair Department

3. We recommend that you insure the package and send it via United Parcel Service wherever possible.

4. Please direct all inquiries to dbx Customer Service Department.

Outside the U.S.A. — contact your nearest dbx dealer for the name and address of the nearest authorized repair center.

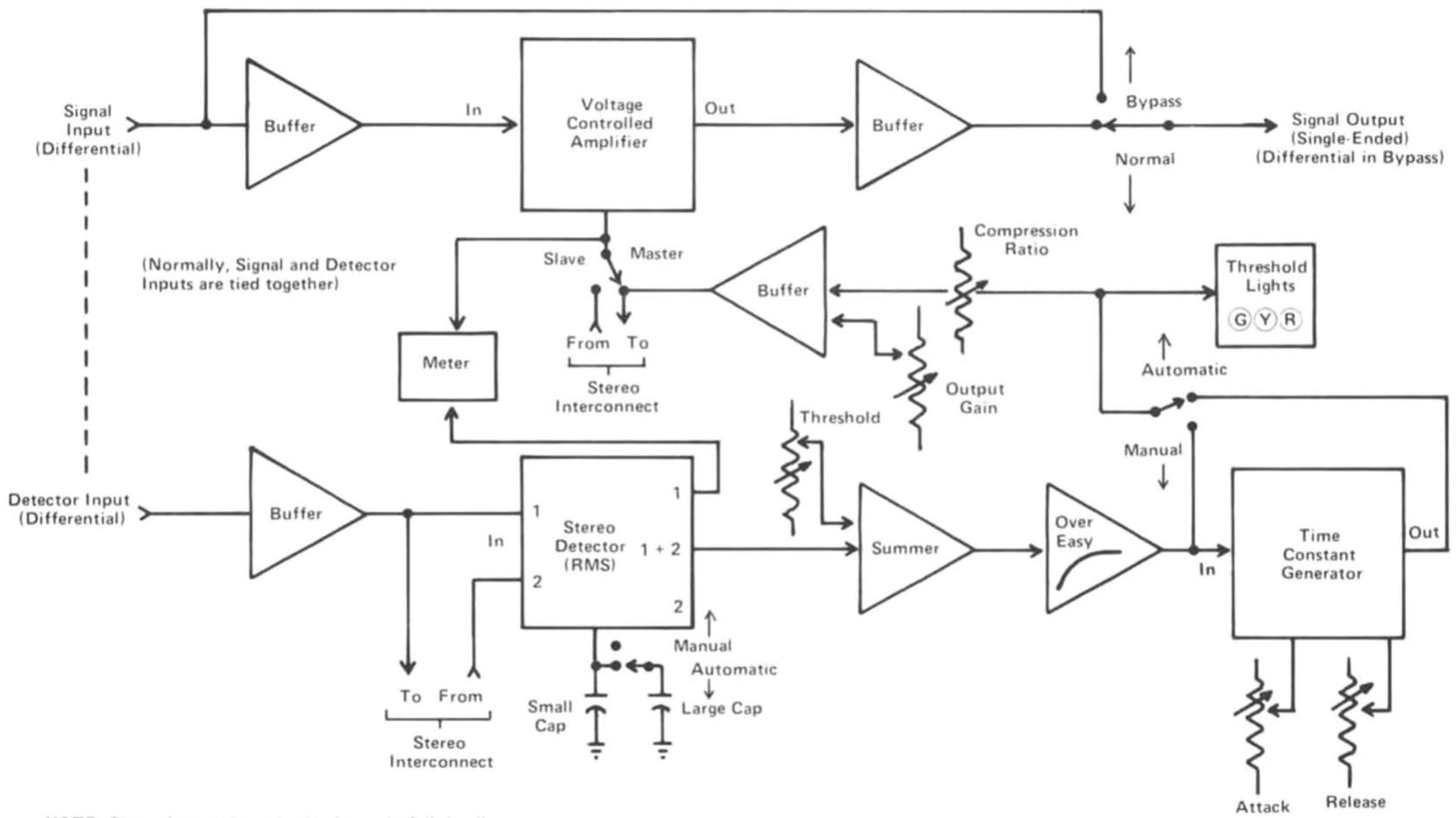

NOTE: Stereo Interconnect is not shown in full detail.
Meter Inputs are not shown in full detail.

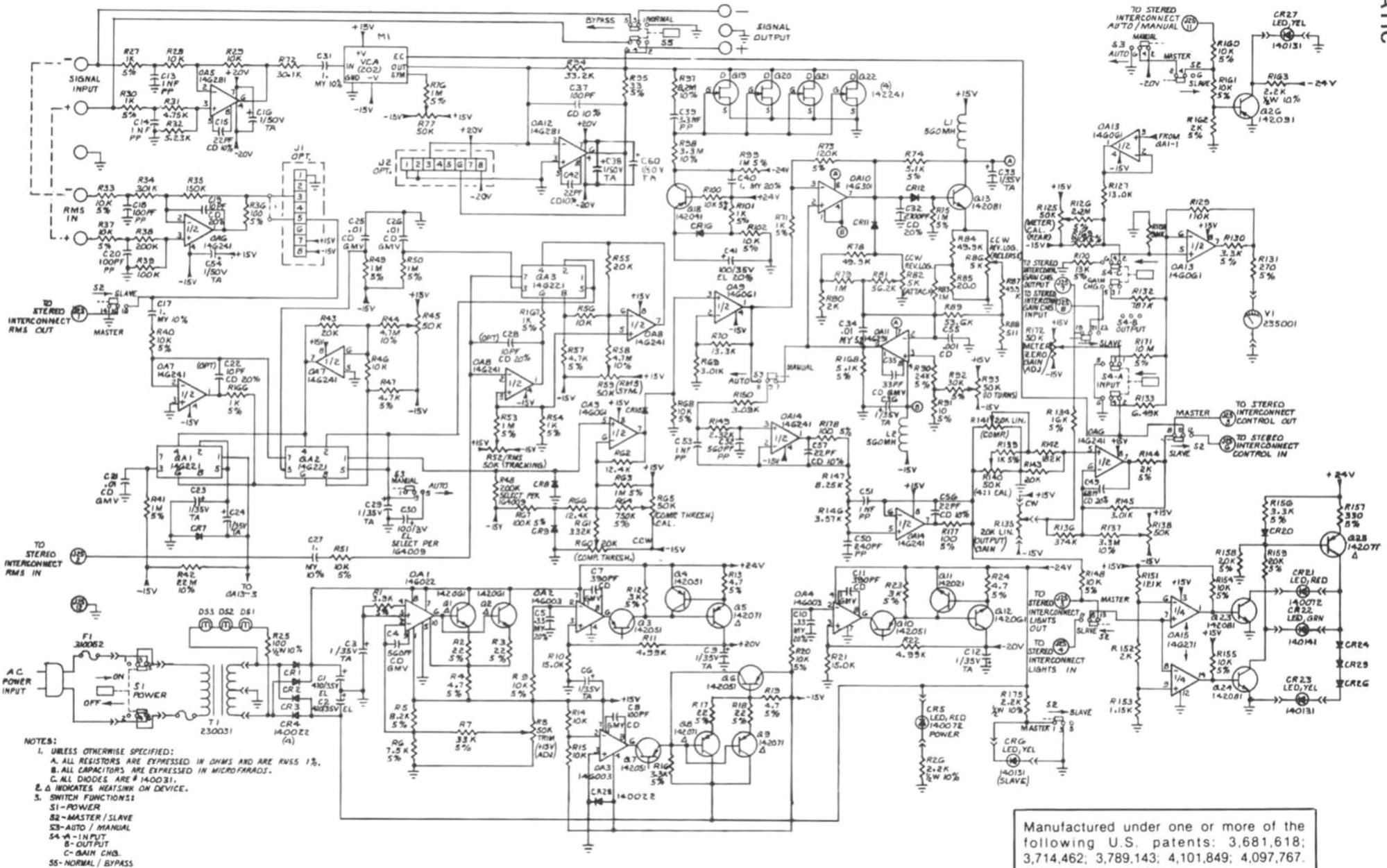

- NOTES:
1. UNLESS OTHERWISE SPECIFIED:
 - A. ALL RESISTORS ARE EXPRESSED IN OHMS AND ARE R5%.
 - B. ALL CAPACITORS ARE EXPRESSED IN MICROFARADS.
 - C. ALL DIODES ARE # 1A0031.
 - D. Δ INDICATES HEATSINK ON DEVICE.
 2. SWITCH FUNCTIONS:
 - S1 - POWER
 - S2 - MASTER SLAVE
 - S3 - AUTO / MANUAL
 - S4 - A - INPUT
 - S - B - OUTPUT
 - C - GAIN CHG.
 - S5 - NORMAL / BYPASS

Manufactured under one or more of the following U.S. patents: 3,681,618; 3,714,462; 3,789,143; 4,101,849; 4,097,767. Other patents pending.

GLOSSARY

Asperity Noise

This is a swishing type of background noise that occurs with tape recordings in the presence of strong low frequency signals, especially when there are no high frequency signals to mask the hiss. Asperity noise is caused by minute imperfections in the surface of the tape, including variations in the magnetic particle size in the tape's oxide coating. The imperfections increase or decrease the strength of the magnetic field passing the play head in a random manner, resulting in audible noise. Asperity noise may be present even when no program is recorded. When a program is recorded, asperity noise becomes superimposed on the signal, creating modulated asperity noise, or "modulation noise." Using high-quality tape with a calendared surface helps reduce asperity and modulation noise (calendared tape is pressed smooth by high-pressure rollers).

Attack Time

Attack time may mean different things, depending on the context. In music, the time it takes for a note to reach its full volume is the attack time of the note. Percussive instruments have short attack times (reach maximum volume quickly) and wind instruments have long attack times (reach maximum volume more gradually).

When a compressor (or expander) changes the level of an incoming signal, the circuitry actually requires a finite amount of time to complete that change. This time is known as the attack time. More precisely, the attack time is the interval (usually measured in milliseconds or microseconds) during which the compressing or expanding amplifier changes its gain from the initial value to 90% of the final value.

Aux Input (Aux Level)

Aux inputs, an abbreviation for auxiliary inputs, are low sensitivity jacks provided on most hi-fi and semi-professional equipment. Aux inputs (also known as "aux level" or "line level" inputs) have "flat" frequency response and are intended to be used with preamplified signals. Aux-level (line-level) signals are medium-level, higher than microphone levels, but not enough power to drive a speaker. The advantage to these levels is that they are less susceptible to hum and noise than are microphone levels. Typical items which might be connected to aux inputs are tape machine "play" outputs, tuner outputs, and dbx "play" outputs. Mic-level or phono-level signals are considerably lower in level than aux inputs (approx. -60 to -40dBV), so they will not produce adequate volume when connected to an aux input. Moreover, phono cartridge outputs require RIAA equalization which is not provided by aux inputs.

Bandwidth

Bandwidth refers to the "space" between two specific frequencies which are upper and lower limits; alternately, bandwidth refers to the absolute value of the range of frequencies between those limits. Thus, a filter which passes frequencies from 1,000Hz to 10,000Hz may be said to have a bandwidth of 1kHz-10kHz, or it may be said to have a 9kHz bandwidth (10kHz minus 1kHz equals 9kHz).

Bandwidth is not necessarily the same as frequency response. Bandwidth may be measured at low levels, and frequency response at higher levels. Moreover, bandwidth may refer only to certain portions of the circuitry within a piece of equipment, whereas frequency response may refer to the overall performance of the equipment. Thus, while the overall input-to-output frequency response of dbx type II equipment is 20Hz to 20kHz, the bandwidth of the RMS detection circuitry within that equipment is 30Hz to 10kHz.

Bass

The low audio frequency range below approximately 500Hz. For the purpose of discussion or analysis, the bass range may be further divided into upper bass (250 to 500Hz), mid bass (100-200Hz), low bass (50-100Hz), and ultra-low bass (20-50Hz).

Bass Boost

An accentuation of the lower audio frequencies (bass frequencies), whereby they are made louder than other frequencies.

Bi-amplified

Descriptive of a sound system which utilizes a low level crossover network to divide the full-spectrum audio signal into low and high frequency ranges. These ranges are then fed to separate power amplifiers, which in turn feed low frequency speakers (woofers) and high frequency speakers (tweeters).

Bias

Bias, as the term is used in tape recording, is a very high frequency signal (usually over 100kHz) that is mixed with the program being recorded in order to achieve linear magnetization of the tape. If only the audio program were applied to the recording head, a very distorted recording would result because lower-energy portions of the program would not be able to overcome the initial magnetization threshold of the tape (known as hysteresis).

The frequency of the bias signal is not critical, so long as the record and erase bias are synchronized. However, the bias

energy level has a direct effect on the recorded level, background noise, and the distortion. It is sometimes necessary to reset the bias level for optimum performance with different types of recording tape, and professional tape machines are equipped with continuously variable bias controls; many consumer tape machines are now equipped with bias selector switches.

Clipping

Clipping is a very distorted sound. It occurs when the output capabilities of an amplifier are exceeded, and the amp can no longer produce any more voltage, regardless of how much additional gain or how much more input signal is present. Clipping is relatively easy to see on an oscilloscope, and it is sometimes audible as an increase in harmonic distortion. In severe cases of clipping (hard clipping), sine-waves begin to resemble square waves, and the sound quality is very poor. Often, the maximum output level of an amplifier is defined as that level where clipping begins to occur. There is a phenomenon known as input clipping, and this may occur where the input signal is so high in level that it exceeds the level-handling ability of the transformer and/or of the input amplifier. Clipping also occurs when tape is saturated by excessive record levels.

So-called "soft clipping" is usually the result of transformer saturation, and it may be somewhat less objectionable than the "hard clipping" that occurs when output voltage limits are reached. Aside from degrading the sound quality, clipping can damage loudspeakers. Output clipping may be avoided by reducing the level of the input signal, reducing the gain of the amplifier, or using a larger amplifier. Input clipping may be avoided by reducing the level of the incoming signal, and then increasing the gain of the amplifier.

Clipping Level

This is the signal level at which clipping just begins to occur. Clipping level is not always easy to define. It may be a matter of visually judging the waveform on an oscilloscope as the level is increased; alternately, clipping level may be defined as the level at which harmonic distortion reaches a given value. Tape clipping, or saturation, is defined as the 3% harmonic distortion level.

Compression

Compression is a process whereby the dynamic range of program material is reduced. In other words, the difference between the lowest and highest audio levels is "squeezed" into a smaller dynamic range. A compressed signal has higher average level, and therefore may have more apparent loudness than an uncompressed signal, even though the peaks are no higher in level. Compression is achieved with a compressor, a special type of amplifier that decreases its gain as the level of the input signal increases. The amount of compression is expressed as a ratio of the input dynamic range to the output dynamic range; thus, a compressor that takes a program input with 100dB of dynamic range and yields an output program of 50dB dynamic range may be said to have a 2:1 compression ratio.

Compressor

A compressor is an amplifier that decreases its gain as the level of the input signal increases to reduce the dynamic range of the program (see "compression"). A compressor may operate over the entire range of input levels, or it may operate only on signals above and/or below a given level (the threshold level).

Crossover Frequency

In loudspeaker systems and multi-amplifier audio systems, the transition frequency (actually a frequency range) between bass and midrange or midrange and treble speakers or amplifiers.

Crossover Network

A circuit which divides the audio spectrum into two or more frequency bands for distribution to different speakers (high level crossover) or different amplifiers which then feed different speakers (low level crossover).

High level crossovers are usually built into the speaker cabinet, and are passive (they require no power supply). Low level crossovers are used in bi-amplified or tri-amplified sound systems. They are usually self-contained, and come before the power amplifiers. Low level crossovers may be passive or active; active low level crossovers are known as "electronic crossovers."

Damping Factor

The ratio of loudspeaker impedance to the amplifier's output source impedance. Damping describes the amplifier's ability to prevent unwanted, residual speaker movement. The higher the numerical value, the better the damping.

DB (Decibel) also, dBv dBV dB SPL dBm dB

One dB is the smallest change in loudness the average human ear can detect. 0dB SPL is the threshold of human hearing whereas the threshold of pain is between 120 and 130dB SPL. The term dB is an abbreviation for decibel, or 1/10 of a Bel. The decibel is a ratio, not an absolute number, and is used to express the difference between two power, voltage or sound pressure levels. (dB is 10 times the

logarithm of a power ratio or 20 times the logarithm of a voltage or sound pressure ratio.) If the number of "dB's" are referenced to a given level, then the value of the dB number becomes specific.

dBv expresses a voltage ratio. 0dBv is usually referenced to 0.775V rms. Thus, 0dBv=0.775V, +6dBv=1.55V (twice 0dBv), +20dBv=7.75V (ten times 0dBv), etc.

dBV expresses a voltage ratio and is similar to dBv, but 0dBV is usually referenced to 1V rms. Thus, 0dBV is 2.2dB higher than 0dBv.

dB SPL expresses a Sound Pressure Level ratio. dB SPL is a measure of acoustic pressure (loudness), not acoustic power, which would be measured in acoustic watts. 0dB SPL is equal to 0.0002 dynes/square centimeter (the threshold of human hearing at 1kHz). As with dBV, an increase of 6dB SPL is twice the sound pressure, and an increase of 20dB SPL is an increase of 10 times the sound pressure.

dBm expresses a power ratio. 0dBm is 1 milliwatt (.001 watts), or 0.775V rms delivered to a 600-ohm load. +3dBm=2 milliwatts, or 1.55V into 600 ohms (twice 0dBm), +10dBm=10 milliwatts, or 7.75V into 600 ohms (ten times 0dBm), etc. dBV and dBm are numerically equal when dealing with 600-ohm circuits. However, when the impedance is other than 600 ohms, the value of dBV remains the same if the voltage is the same, whereas the value of dBm decreases with increasing impedance.

dB alone, without any suffix, doesn't mean anything unless it is associated with a reference. It may express the difference between two levels. Thus, the difference between 10dBV and 15dBV, the difference between 0dBm and 5dBm, and the difference between 90dB SPL and 95dB SPL are all differences of 5dB.

Decay Time

Decay time may mean different things, depending on the context. A compressor's decay time is also known as its release time or recovery time. After a compressor (or expander) changes its gain to accommodate an incoming signal, and the signal is then removed, the decay time is the amount of time required for the circuitry to return to "normal." More precisely, the decay time is the interval (usually measured in microseconds) during which the compressing or expanding amplifier returns to 90% of the normal gain. Very fast decay times can cause "pumping" or "breathing" effects, whereas very slow decay times may cause moderate-level program which follows high-level program or program peaks to be too low in level.

Decoder

When a circuit restores an original program from a specially treated version of that program, the circuit may be said to decode the program. The equipment or circuit which performs this function is known as a decoder. Decoders must be used only with programs which have been encoded by complementary encoding circuitry. Typical decoders include: FM tuners that use multiplex decoders to extract left and right stereo signals from left-plus-right and left-minus-right signals, matrix quadraphonic decoders that extract four channels of program from the stereo program on encoded recordings, and dbx decoders that retrieve wide-dynamic range programs from the compressed programs on dbx-encoded recordings.

De-emphasis & Pre-emphasis

De-emphasis and pre-emphasis are related processes that are usually done to avoid audio noise in some storage or transmission medium. Pre-emphasis is a boost at specific higher frequencies, the encoding part of an encoding/decoding system. De-emphasis is an attenuation at the same frequencies, a reciprocal decoding that counteracts the pre-emphasis. In dbx noise reduction, de-emphasis is performed by the decoder (the play circuitry). The de-emphasis attenuates high frequencies, thereby reducing tape modulation noise and restoring the original frequency response of the program before it was dbx encoded. There are other types of pre-emphasis and de-emphasis. For example, in FM tuners, de-emphasis is used to compensate for special equalization (known as 75-microsecond pre-emphasis) applied at the station's transmitter.

Dynamic Range

The dynamic range of a program is the range of signal levels from the lowest to the highest level. In equipment, the dynamic range is the "space," in dB, between the residual noise level and the maximum undistorted signal level. A program with wide dynamic range has a large variation from the softest to the loudest passages, and will tend to be more lifelike than programs with narrow dynamic range.

Encoder

When a circuit processes an original program to create a specially treated version of that program, the circuit may be said

to encode the program. The equipment or circuit which performs this function is known as an encoder. Encoded programs must be decoded only with complementary decoding circuitry. Typical encoded programs include: FM multiplex broadcasts, matrix quadraphonic recordings, and dbx encoded recordings.

Envelope

In music, the envelope of a note describes the change in average signal level from initial attack, to peak level, to decay time, to sustain, to release time. In other words, the envelope describes the level of the note as a function of time. Envelope does not refer to frequency.



The outline is the envelope, the signal is within the envelope.

In fact, any audio signal may be said to have an envelope. While all audio frequencies rise and fall in instantaneous level from 40 to 40,000 times per second, an envelope may take many milliseconds, seconds or even minutes to rise and fall. In dbx processing, the envelope is what "cues" the rms level detection circuitry to compress and expand the signal; the peak or average level of individual cycles of a note would be useless for level detection because the gain would change much too rapidly for audibly pleasing sound reproduction.

EQ (Equalization)

EQ or equalization, is an intentional change in the frequency response of a circuit. EQ may be used for boosting (increasing) or cutting (decreasing) the relative level of a portion of the audible spectrum. Some EQ is used for achieving sound to suit personal listening tastes, while other types of EQ are specifically designed to correct for non-linearities in the system; these corrective EQ "curves" include tape (NAB or CCIR) equalization, and phonograph (RIAA) equalization. In a sense, the pre-emphasis and de-emphasis used in dbx processing are special forms of equalization.

There are two common types of Equalization curves (characteristics): PEAKING and SHELIVING. Shelving EQ is used in most Hi-Fi bass and treble tone controls. Peaking EQ is used in Hi-Fi midrange tone controls, in graphic equalizers, and many types of professional sound mixing equipment.

EQ is performed by an equalizer, which may be a specially built piece of equipment, or it may be no more than the tone control section of an amplifier. Graphic equalizers have many controls, each affecting one octave, one-half octave, or one-third octave of the audio spectrum. (An octave is the interval between a given tone and its repetition eight tones above or below on the musical scale; a note which is an octave higher than another note is twice the frequency of the first note.)

Expander

An expander is an amplifier that increases its gain as the level of the input signal increases, a characteristic that "stretches" the dynamic range of the program (see "expansion"). An expander may operate over the entire range of input levels, or it may operate only on signals above and/or below a given level (the threshold level).

Expansion

Expansion is a process whereby the dynamic range of program material is increased. In other words, the difference between the lowest and highest audio levels is "stretched" into a wider dynamic range. Expansion is sometimes used to restore dynamic range that has been lost through compression or limiting done in the original recording or broadcast; expansion is an integral part of compressor-type noise reduction systems, including dbx. Expansion is achieved with an expander, a special type of amplifier that increases its gain as the level of the input signal increases. The amount of expansion is expressed as a ratio of the input dynamic range to the output dynamic range; thus, an expander that takes a program input with 50dB of dynamic range and yields an output program of 100dB dynamic range may be said to have a 1:2 compression ratio.

Fundamental

A musical note is usually comprised of a basic frequency, plus one or more whole-number multiples of that frequency. The basic frequency is known as the fundamental, and the multiples are known as harmonics or overtones. A pure tone would consist of only the fundamental.

Ground Compensated Output

This is a sophisticated output circuit that senses the potential difference between the ground of the dbx unit and the shield ground of unbalanced inputs to which the dbx unit is connected. Ideally, the dbx unit and the input of the following device should be at the same level (potential). However, where grounding is not "right" (where so-called "ground loops" exist), this circuit calculates the ground error and adds a correction signal to the high side of the output, thereby cancelling much of the hum, buzz and noise that might otherwise have been introduced by ground loops.

Harmonic Distortion

Harmonic distortion consists of signal components appearing at the output of an amplifier or other circuit that were not present in the input signal, and that are whole-number multiples (harmonics) of the input signal. For example, an amplifier given a pure sine-wave input at 100Hz may produce 200Hz, 300Hz, 400Hz, 500Hz, 600Hz and even 700Hz energy, plus 100Hz, at its output (these being the 2nd, 3rd, 4th, 5th, 6th and 7th order harmonics). Usually, only the first few harmonics are significant, and even-order harmonics (i.e. 2nd and 4th) are less objectionable than odd-order harmonics (i.e. 3rd and 5th); higher harmonics may be negligible in comparison to the fundamental (100Hz) output. Therefore, rather than specifying the level of each harmonic component, this distortion is usually expressed as T.H.D. or Total Harmonic Distortion. While T.H.D. is the total power of all harmonics generated by the circuitry, expressed as a percentage of the total output power, the "mixture" of different harmonics may vary in different equipment with the same T.H.D. rating.

Harmonics

Overtones which are integral multiples of the fundamental.

Headroom

Headroom refers to the "space," usually expressed in dB, between the nominal operating signal level and the maximum signal level. The input headroom of a circuit that is meant to accept nominal -10dB levels, but can accept up to +18dB without overdrive or excessive distortion, is 28dB (from -10 to +18 equals 28dB). Similarly, the output headroom of a circuit that is meant to supply nominal +4dBm drive levels, but that can produce +24dBm before clipping is 20dB. A circuit that lacks adequate headroom is more likely to distort by clipping transient peaks, since these peaks can be 10 to 20dB above nominal operating signal levels.

I.M. (Intermodulation Distortion)

Intermodulation distortion consists of signal components appearing at the output of an amplifier or other circuit that were not present in the input signal, that are not harmonically related to the input, and that are the result of interaction between two or more input frequencies. I.M. distortion, like harmonic distortion, is usually rated as a percentage of the total output power of the device. While some types of harmonic distortion are musical, and not particularly objectionable, most I.M. distortion is unpleasant to the ear.

Impulse Response

Related to the rise time of a circuit, the impulse response is a measurement of the ability of a circuit to respond to sharp sounds, such as percussion instruments or plucked strings. A circuit with good impulse response would tend to have good transient response.

Level Match

The dbx noise reduction system is unlike competitive systems in that there is no one threshold at which compression or expansion begins. Instead, compression occurs linearly, with respect to decibels, over the full dynamic range of the program. By necessity, there is an arbitrary signal level which passes through the encoder and decoder without being changed in level. This level is known as the level match point (transition point). Some dbx equipment provides for user adjustment of the level match point, for monitoring purposes only. Although this is not necessary for proper encode/decode performance, by setting the level match point to be approximately equal to the nominal (average) signal level, there will be no increase or decrease in level as you switch from monitoring "live" program to monitoring dbx-processed program.

Limiter

A limiter is a type of compressor, one with a 10:1 or greater compression ratio. A limiter with a high compression ratio (120:1) can be set so that no amount of increase in the input signal will be able to raise the output level beyond a preset value. The difference between limiting and compression is that compression gently "shrinks" dynamic range, whereas limiting is a way to place a fixed "ceiling" on maximum level, without changing the dynamic range of program below that "ceiling," or threshold.

Line Level (Line Input)

Line level refers to a preamplified audio signal, in contrast to mic level, which describes a lower-level audio signal. The actual signal levels vary. Generally, mic level is nominally -50dBm (with typical dynamic range of -64dBm to +10dBm). Line level signals vary, depending on the audio system. Hi-Fi line levels are nominally -15dBV, whereas professional line levels are nominally +4dBm or +8dBm (with typical dynamics ranging from -50dBm to +24dBm).

Line inputs are simply inputs that have sensitivities intended for line level (preamplified) signals. Often, the nominal impedance of a line level input will be different than the nominal impedance of a mic level input.

Modulation Noise

Modulation noise is a swishing type of background hiss that occurs with tape recordings in the presence of strong low frequency signals. The noise depends on the level of the recorded signal; the higher the recorded signal level, the higher the modulation noise. Modulation noise has typically been "masked," hidden by the dominant signal and/or by the background hiss of the tape. However, when the background hiss is removed, as with dbx processing, modulation noise could become audible. This would happen primarily with strong, low-frequency signals, but in fact it is minimized by dbx's pre-emphasis and de-emphasis.

Octave

In music or audio, an interval between two frequencies having a ratio of 2:1.

Overshoot

When a compressor or expander changes its gain in response to a fast increase or decrease in level, the maximum gain change should be directly proportional to the actual signal level. However, in some compressors the level detection and gain changing circuitry develop a kind of "inertia," over-reacting to changes in level, increasing or decreasing the gain more than the fixed ratio asked for. This over-reaction is known as overshoot, and it can cause audibly non-linear compression (distortion). dbx circuits have minimal overshoot, so they provide highly linear compression and expansion.

Peak Level

An audio signal continuously varies in level (strength, or maximum voltage) over any period of time, but at any instant, the level may be higher or lower than the average. The maximum instantaneous value reached by a signal is its peak level (see RMS level).

Phase Shift

"Time shift" is another way to describe phase shift. Some circuitry, such as record electronics and heads, will delay some frequencies of an audio program with respect to other portions of the same program. In other words, phase shift increases or decreases the delay time as the frequency increases. On an absolute basis, phase shift cannot be heard, but when two signals are compared to one another, one having a phase shift relative to the other, the effects can be very noticeable, and not very desirable. Excessive phase shift can give a tunnel-like quality to the sound. Phase shift also can degrade the performance of compander type noise reduction systems which depend on peak or average level detection circuitry.

Power Amplifier

A unit that takes a medium-level signal (e.g., from a pre-amplifier) and amplifies it so it can drive a loudspeaker. Power amplifiers can operate into very low impedance loads (4-16 ohms), whereas preamplifiers operate only into low impedance (600 ohms) or high impedance (5,000 ohms or higher) loads. Also known as a main amplifier, the power amplifier may be built into an integrated amplifier or a receiver.

Preamplifier

A device which takes a small signal (e.g., from a microphone, record player), or a medium-level signal (e.g., from a tuner or tape recorder), and amplifies it or routes it so it can drive a power amplifier. Most preamplifiers incorporate tone and volume controls. A preamp may be a separate component, or part of an integrated amplifier or of a receiver.

Pre-Emphasis (See "de-emphasis")

Receiver

A single unit that combines tuner, preamp and power amplifier sections.

Release Time or Release Rate (See "decay time" and "attack time")

Rise Time (Attack Time)

This is the ability of a circuit to follow (or "track") a sudden increase in signal level. The shorter the rise time, the better the frequency response. Rise time is usually specified as the interval (in microseconds) required to respond to the leading edge of a square-wave input.

RMS Level

RMS level (Root Mean Square) is a measurement obtained by mathematically squaring all the instantaneous voltages along the waveform, adding the squared values together, and taking the square root of that number. For simple sine waves, the RMS value is approximately 0.707 times the peak value, but for complex audio signals, RMS value is more difficult to calculate. RMS level is similar to average level, although not identical (Average level is a slower measurement).

Sub Harmonic

A sub-multiple of the fundamental frequency. For example, a wave the frequency of which is half the fundamental frequency of another wave is called the second sub harmonic of that wave.

Sub Woofer

A loudspeaker made specifically to reproduce the lowest of audio frequencies, usually between 20Hz and 100Hz.

Synthesizer

An ELECTRONIC MUSIC SYNTHESIZER is an audio processor that has a built-in sound generator (oscillator), and that alters the envelope of the sound with voltage controlled circuitry. Synthesizers can produce familiar sounds and serve as musical instruments, or they can create many unique sounds and effects of their own.

A SUB HARMONIC SYNTHESIZER is a device which is not used to create music, but to enhance an existing audio program. In the case of the dbx Model 100, the unit creates a new signal that corresponds to the volume of the input signal, but is at 1/2 the frequency of the input signal.

Tape Saturation

There is a maximum amount of energy that can be recorded on any given type of magnetic tape. When a recorder "tries" to record more energy, the signals become distorted, but are not recorded at any higher levels. This phenomenon is called tape saturation because the magnetic oxide particles of the tape are literally saturated with energy and cannot accept any more magnetization.

T.H.D. (Total Harmonic Distortion) (See "Harmonic Distortion")

Threshold

Threshold is the level at which a compressor or limiter ceases to have linear gain, and begins to perform its gain-changing function (i.e., where the output level no longer rises and falls in direct proportion to the input level). In most systems, the threshold is a point above which the level changes, although there are compressors that raise signal levels below a threshold point. Some compander-type noise reduction systems, such as Dolby[®], have upper and lower threshold between which the gain changes; these systems require careful level calibration for proper encode/decode performance. dbx noise reduction systems have no threshold at which compression or expansion factors change, so level calibration is not critical.

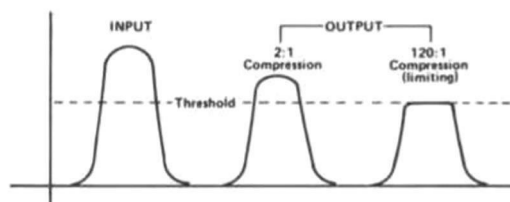

Tracking Accuracy

Tracking refers to the ability of one circuit to "follow" the changes of another circuit. When two volume controls are adjusted

in exactly the same way, the corresponding "sameness" of the output levels can be expressed as the tracking accuracy of the controls.

The level detection circuitry in a dbx encoder senses the signal level, changes the gain, and creates an encoded signal. The corresponding "sameness" of the original signal and the encoded/decoded signal can be expressed as the tracking accuracy of the noise reduction system. (dbx systems are non-critical for the operator, and are built to close tolerances, so that tracking accuracy is excellent, even if the encoder and decoder are in different pieces of dbx equipment.)

Transition Level (See Level Match)

When a circuit has uniform compression or expansion throughout its full dynamic range, there must be some level which passes through the unit without being raised or lowered (where gain is unity). This unity gain level is the transition level or transition point. The transition point is a "window" 1dB wide, in a dbx encoder (compressor), all signals above the transition point are decreased in level, and all signals below the point are increased in level. Conversely, in a dbx decoder (expander), all signals above the transition point are increased in level, and all signals below the point are decreased in level. The transition level is similar to a "threshold," except it does not refer to a point at which compression or expansion factors change.

Triamplified

Similar to biamplified. A sound system where a passive crossover network creates three frequency ranges, and feeds three power amplifiers: one for bass, one for mid, and one for high frequencies. The amplifiers are connected directly to the woofers, midrange drivers and tweeters without a passive, high-level crossover network.

Tuner

A unit which receives radio broadcasts and converts them into audio frequency signals. May be part of a receiver.

VCA (Voltage Controlled Amplifier)

Traditionally, amplifiers have been designed to increase signal levels (to provide gain). If an amplifier were required to decrease the level (to attenuate), it could become unstable, and might even oscillate. The gain (amount of amplification) in these traditional amplifiers would be adjusted by one of three methods (1) attenuating the audio signal fed to the input of the amplifier, (2) attenuating the audio output of the amplifier, or (3) changing the negative feedback (feeding more or less signal from the output back to the input, but in reversed polarity).

The VCA is a special type of amplifier that can be used to increase or decrease levels over a wide dynamic range. Instead of using signal attenuation or negative feedback, the gain (or loss) is adjusted by means of an external dc control voltage. dbx has a unique, patented VCA design that has extremely low noise and very wide dynamic range; the dbx VCA is the heart of dbx noise reduction equipment.

Woofer

A loudspeaker which reproduces only low frequencies.

*Dolby[®] is a trademark of Dolby[®] Laboratories, Inc.

Manufactured under one or more of the following U.S. patents: 3,681,618; 3,714,462; 3,789,143; 4,101,849; 4,097,767. Other patents pending.

scans von archive-org