



## Table of Contents

page	contents
1	Introduction
3	Front Panel
6	Rear Panel
8	Connecting The 160XT To Your System
8	System Connections
12	Multi-Channel Connections
13	Special Connections (OPTIONAL)
13	Using External Level Detector Inputs
14	Basic Operation (Control Descriptions)
18	Specific Applications
23	Installation Considerations
23	Power Considerations
23	Mounting the 160XT in a Rack (OPTIONAL)
24	Input Cable Configurations
26	Output Cable Considerations
28	Transformer Balanced (OPTIONAL)
29	Grounding
30	Maintenance and Technical Support
30	Maintenance and Troubleshooting
30	Technical Support
30	Factory Service
31	Shipping Instructions
32	Specifications
34	Schematic (160XT Main Board)
35	Glossary
51	Registration, Warranty
51	Registration Card
51	Warranty
51	User-Feedback



**CAUTION:** TO REDUCE THE RISK OF ELECTRICAL SHOCK, DO NOT REMOVE COVER (OR BACK). NO USER SERVICEABLE PARTS INSIDE. REFER SERVICING TO QUALIFIED SERVICE PERSONNEL.

**WARNING:** TO REDUCE THE RISK OF FIRE OR ELECTRICAL SHOCK, DO NOT EXPOSE THIS APPLIANCE TO RAIN OR MOISTURE.



This symbol, wherever it appears, alerts you to the presence of uninsulated dangerous voltage inside the enclosure — voltage that may be sufficient to constitute a risk of shock.



This symbol, wherever it appears, alerts you to important operating and maintenance instructions in the accompanying literature. Read the manual.

This dbx-branded product has been manufactured by AKG Acoustics, Inc. under one or more of the following U.S. patents: 3,377,792; 3,681,618; 3,714,462; 3,789,143; 4,097,767; 4,329,598; 4,403,199; 4,409,500; 4,425,551; 4,473,795. Other patents pending.

This manual is part number 95096-000-01  
© Copyright 1990 by AKG Acoustics, Inc.

dbx Professional Products  
a division of AKG Acoustics, Inc.  
1525 Alvarado Street, San Leandro, CA 94577 USA  
Telephone (1) 415/351-3500 Fax: (1) 415/351-0500 Telex: 17-1480

## Introduction

dbx 160XT



Congratulations on purchasing the dbx Model 160XT Compressor/Limiter. We recommend you take a moment and read through the manual as it provides information that will assist you from system installation to operation to special applications. For a basic understanding of the terms used in this manual, there is a Glossary of important terms located in the back of the manual.

We have added a few new features to the dbx Model 160XT while maintaining the performance and ease of operation of its predecessor, the dbx 160X. We have added:

**XL-type Input and Output Connectors** – because the 3-pin XL connector has been recognized as the most durable and widely used connector for professional applications.

**Balanced Output** – can drive a 600Ω load to +24dBu and provides common-mode rejection of unwanted noise in the audio path such as RF and 60Hz components.

**True Power Summing** – When two 160XT units are slaved together, the RMS energy of the signal presented to the slave unit is summed with the RMS energy of the signal presented to the master unit to prevent phase cancellation of the two signals from causing unmusical compressor action. Note: a 160X unit can also be used with the same results as long as the 160XT is used as the master unit.

**Input Ground-Lift Switch** – for isolation between shield ground and signal ground. Useful when troubleshooting hum (AC line interference).

# Introduction

Other features include:

**OVER EASY®/Hard Knee Selection** – allows selection between our famous Over Easy compression curve and the classic “Hard Knee” curve popularized by the original dbx 160, 161 and 162.

**True RMS Level Detection** – senses the power in the program in a musical manner, much as the ear does, giving results superior to peak or average detection.

**Hardwire System Bypass Switch** – allows the audio to pass even if the unit is unplugged, and is also useful for comparing the processed and unprocessed signal.

**Front Panel Stereo Coupling Switch** – couples two 160XTs or a 160XT and a 160X together for stereo operation at the push of a button.

**19 Segment Display** – for high resolution monitoring of True RMS input and output levels.

**12 Segment Display** – indicating GAIN REDUCTION.

**Meter Calibration** – input/output meter calibration, so the 160XT can be used in a variety of situations where the “0” reference is not consistent.

**¼” Input and Output Connectors** – we kept the ¼” phone jacks from the 160X, with the

output capable of driving its own additional 600Ω load (single-ended) in addition to any load at the XL output.

**Detector Input** – useful for special applications including frequency conscious compression in which an external equalizer is used.

**DC-controlled Parameters** – the signal does not pass thru any of the parameter controls. Instead a DC voltage controls all functions which eliminates any possibility of potentiometer noise as the controls age.

The dbx 160XT is capable of handling a wide range of applications. In the studio, the 160XT can be used on everything from vocals to percussion. In live sound reinforcement, the 160XT can allow the engineer to get that “fat studio sound” out of the drum kit or provide protection limiting for the speakers. In radio or television broadcast, the 160XT will produce stable voice levels, even with non-professional subjects.

2

## Front Panel

dbx 160XT

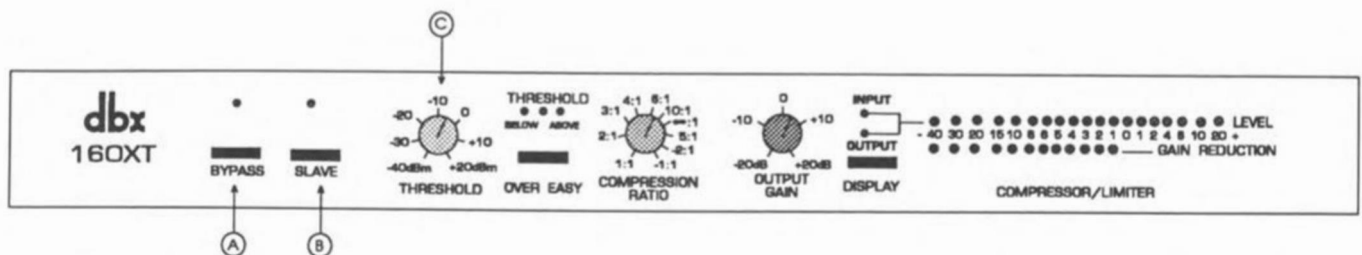

Figure 1: Front Panel

### A. BYPASS switch and indicator

Depressing the BYPASS button creates a “hard-wire bypass” of the 160XT’s circuitry by connecting the input directly to the output; If the 160XT is being provided with AC power, an LED above the switch turns ON in Bypass mode.

### B. SLAVE switch and indicator

Depressing the SLAVE button on one 160XT of a stereo pair determines that the *other* 160XT will be the Master (the controlling unit). The LED above the SLAVE button turns ON when the 160XT is in Slave mode, indicating that the front panel functions (with the exception of BY-

PASS and DISPLAY select switches) are deactivated and under control of the Master 160XT. When neither 160XT is in Slave mode, each will operate normally as a single channel compressor/limiter.

### C. THRESHOLD control

Adjusting this knob sets the threshold of compression from -40dBu (7.8mVrms) to +20dBu (7.8Vrms).

# Front Panel

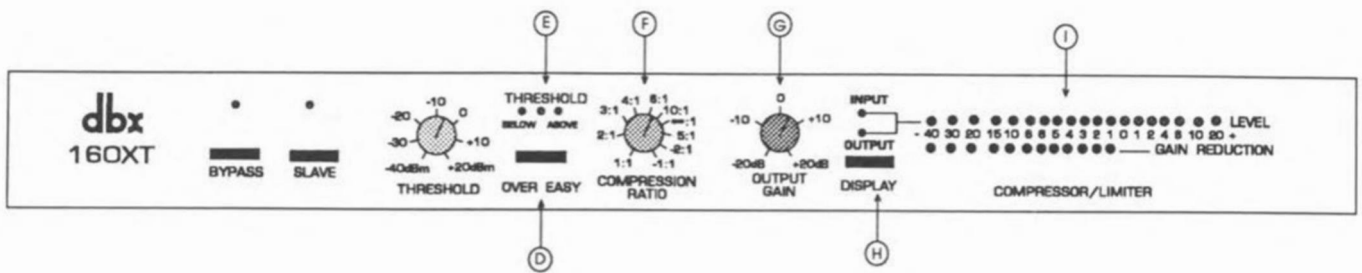

Figure 2: Front Panel

## D. OVER EASY switch

Depressing this button selects the Over Easy<sup>®</sup> compression characteristic. The amber THRESHOLD LED turns ON when the signal is in the Over Easy region. When this button is out, the 160XT operates as a hard-knee compressor/limiter.

In hard-knee compression mode, the threshold is defined as that point above which the output level no longer changes on a 1:1 basis with changes in the input level. In Over Easy mode, the threshold of compression is defined as the middle of the Over Easy threshold region, that

is, "half-way" into compression, as shown in Figure (See Figure 13).

## E. THRESHOLD indicators

These three LEDs indicate the relationship of the input signal level to the threshold of compression. The green "BELOW" LED is ON when the signal is below threshold and the red "ABOVE" LED is ON when the signal is above threshold. When the 160XT is switched to Over Easy mode, the amber LED is ON when the signal is in the Over Easy region (See Figure 13).

4

# Front Panel

dbx 160XT

## F. COMPRESSION RATIO control

Rotating this control clockwise increases the amount of compression from 1:1 (no compression) up to infinity:1 (no increase in output level, regardless of input level increases above threshold); further clockwise rotation increases compression into the INFINITY+ region, up to a maximum of -1:1 (i.e., a 1dB increase in input level above threshold causes a 1dB decrease in output level). In the INFINITY+ region, the 160XT inverts the program dynamics for special effects.

## G. OUTPUT GAIN control

Adjusting this control varies the amount of fixed gain (up to  $\pm 20$ dB) in the 160XT's output amplifier stage. The OUTPUT GAIN control does not interact with the threshold of compression.

## H. DISPLAY switch and indicator

Depressing this button causes the upper LED array to display the INPUT level to the 160XT. With the button out, the OUTPUT level is displayed. A pair of LEDs immediately above the DISPLAY switch indicates the selected display status.

## I. LEVEL and GAIN REDUCTION displays

The upper row of 19 LEDs displays either the INPUT or OUTPUT level, as selected with the DISPLAY switch. This display is factory set so that 0dB is equivalent to +4dBu input or output level (1.23Vrms), but may be reset with the rear panel METER CALIBRATION trimmer. (See following pages.)

The lower row of 12 LEDs displays up to 40dB of GAIN REDUCTION caused by the 160XT. (Fixed gain changes due to the OUTPUT GAIN control are not displayed by the GAIN REDUCTION LEDs but are reflected in the OUTPUT level display.)

# Rear Panel

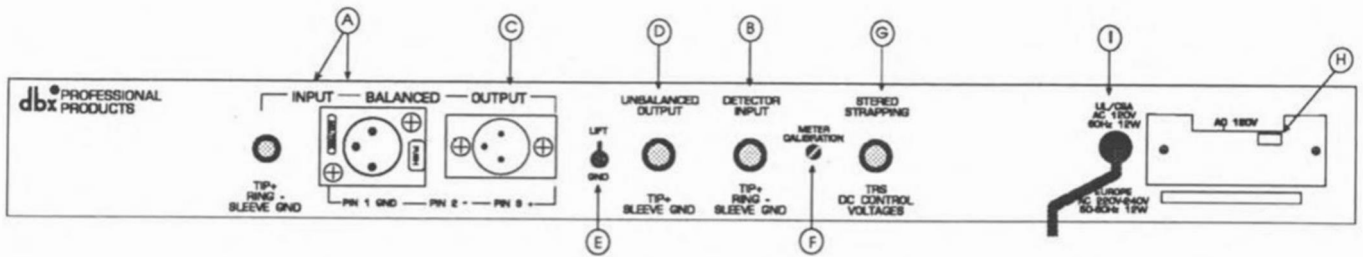

Figure 3: Rear Panel

## A. SIGNAL INPUT jacks

The Tip/Ring/Sleeve phone jack and XL-type connector are wired in parallel; either Signal Input will accept an audio signal for processing by the 160XT. The phone jack accepts a standard TRS 1/4" phone plug for a balanced input source, or a 2-circuit (Tip/Sleeve) 1/4" phone plug for an unbalanced source. The XL-type plug connector is wired pin 3 HOT (+), pin 2 COLD (-) and pin 1 GROUND.

## B. DETECTOR INPUT

This Tip/Ring/Sleeve phone jack accepts a standard TRS 1/4" phone plug, and is of the

"normalizing" type. That is, when a phone plug is inserted, the detector input is no longer connected in parallel with the audio input.

## C. SIGNAL OUTPUT - XL-type connector

The 160XT has an active-balanced amplifier capable of driving a 600 ohm (or greater) load to +24dBu. Pin 3 is the HOT (+) lead, pin 2 is the COLD (-) lead and pin 1 is circuit ground. Do not short either pin 2 or pin 3 to ground, unless you have installed the optional transformer. This will not damage the unit, but may increase distortion. (See page 28 for transformer balancing options.)

# Rear Panel

dbx 160XT

## D. SIGNAL OUTPUT - phone jack

The 160XT has a separate single-ended (unbalanced) output amplifier also capable of driving a 600 ohm (or greater) load to +24dBu. In normal operation the Tip/Ring/Sleeve phone jack is internally wired with the TIP HOT (+), and the RING and SLEEVE connected to circuit ground. In BYPASS mode, however, the RING is connected to the COLD (-) leads of the input jacks, to allow for 1:1 connections.

## E. GROUND (GND) Lift switch

This switch allows for troubleshooting hum (line interference) caused by ground loops. In the "GND" position, pin 1 of the input XL-type connector is connected to the 160XT's circuit ground. In the "LIFT" position it is disconnected. This is not a chassis-isolate switch. The circuit ground is floating with the respect to the chassis.

## F. METER CALIBRATION control

This screw-driver-adjustable trimmer may be used to precisely calibrate the front panel's upper LED display so a 0dB INPUT or OUTPUT indication is equivalent to any signal from -15dBu (138mVrms) to +10dBu (2.45Vrms).

## G. STEREO STRAPPING jack

When a TRS (Tip/Ring/Sleeve) 1/4" phone plug patch cable is inserted between two 160XTs, stereo strapping can be achieved by depressing the SLAVE switch on one unit only. This will provide accurate processing for a stereo programming.

## H. AC line voltage requirement indicator

This recessed indicator displays the nominal AC line voltage for which the 160XT has been set at the factory.

## I. AC power cable

Connect this cable to any 50Hz or 60Hz AC power source of the correct line voltage, as shown by the AC LINE VOLTAGE requirement indicator above. The Model 160XT consumes a maximum of 12 watts AC power.

**WARNING:** Be sure to verify both your actual line voltage and the voltage for which your Model 160XT was wired, as indicated on the rear panel of your unit. Connection to an inappropriate power source may result in extensive damage which is not covered by the warranty.



# Connecting The 160XT To Your System

## System Connections

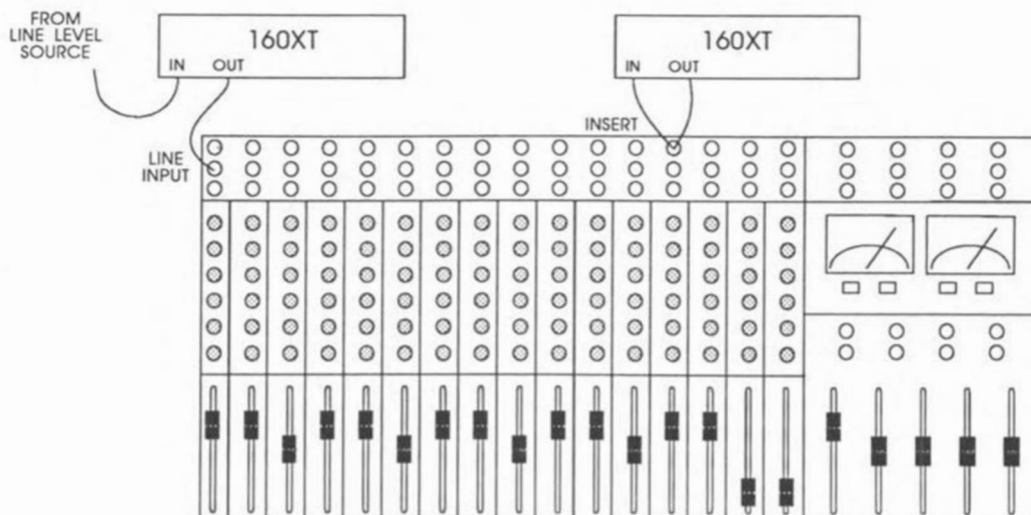

Figure 4: Connecting a 160XT to a Mixing Board

The 160XT has balanced inputs and outputs, and can be used with any line-level device. Some common examples include: mixing consoles, musical instruments, patch bays, and other signal processors.

### A. Mixing Board:

If you wish to compress a particular track of a multi-track recording or one channel of a live performance mix, the 160XT output can be directly connected to a line input jack (balanced or not), or wired to an Insert point. In the latter case, the signals will most likely be unbalanced.

8

# Connecting The 160XT To Your System

dbx 160XT

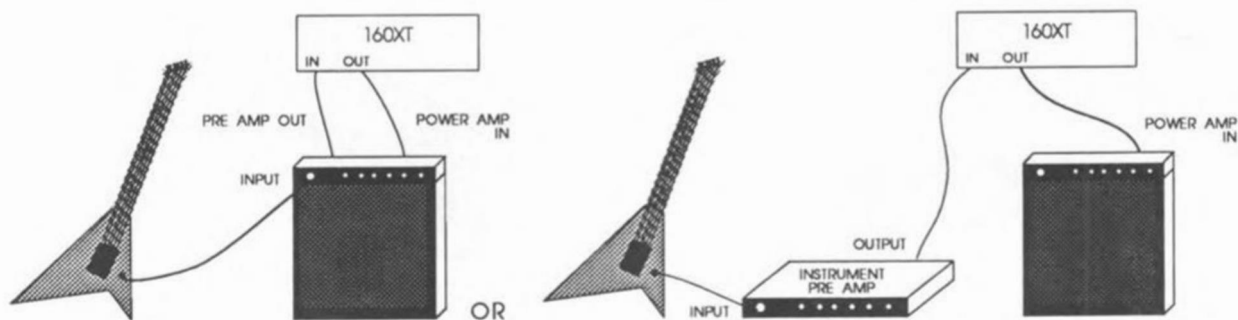

Figure 5: Connecting a 160XT to a Guitar

### B. Musical Instruments (i.e., Electric Guitar, Bass, Keyboards):

The output of an electric guitar is not usually "hot" enough to drive the 160XT's input. Therefore you must use the "PREAMP OUT" of your guitar amp (if so equipped), or the output of some other device that is designed to accept low-level instrument inputs (including various stomp boxes and rack mount audio products, like the dbx Performer Series processing units). Such sources can be balanced or unbalanced,

but this is no problem for the 160XT (see Figure 5).

Microphones and bass guitars, like guitars, also typically have low-level outputs.

Instruments like keyboards typically produce a line-level signal and can be connected directly from the instrument's output to the 160XT's input (see Figure 6).

9

# Connecting The 160XT To Your System

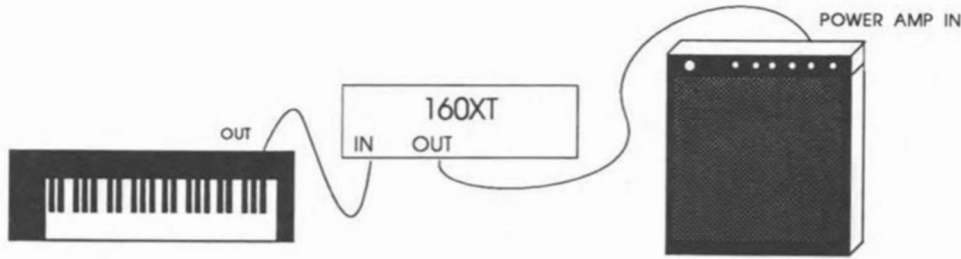

Figure 6: Connecting a 160XT to a Keyboard

### C. Patch bay:

In the studio, the 160XT may be connected to a patch bay to allow it to be used anywhere in the studio system. Do not ground Pin 2 (or 3) of the XL-type output connector (distortion can result). If your studio is not fully balanced, you should leave pin 2 disconnected or use the 1/4" phone jack output, which is single-ended. Another option is to install an output transformer,

which will allow grounding of either pin 2 or 3 of the XL-type output (see page 28).

# Connecting The 160XT To Your System

dbx 160XT

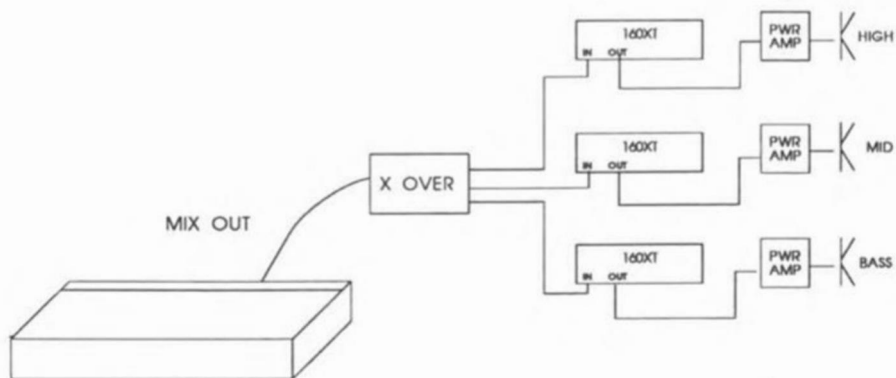

Figure 7: Connecting 160XTs for Sound Reinforcement

### D. Sound reinforcement:

To compress a live mix or to protect loudspeakers, connect the 160XT between the source (mixing board or distribution amp) and the power amp(s). If multi-way loudspeakers with low-level electronic crossovers are used, the 160XT(s) should go after the crossover(s). Figure 7 shows three 160XTs used in a tri-amped (multi-way) setup. For a stereo system, you can separately stereo couple the two high band crossovers, low band crossovers, etc. (see next

page). If limitations require that you use a single 160XT before a crossover, adding an equalizer to the side chain may provide some additional protection to your high frequency component (see "Specific Applications," page 21).

# Connecting The 160XT To Your System

## Multi-Channel Connections

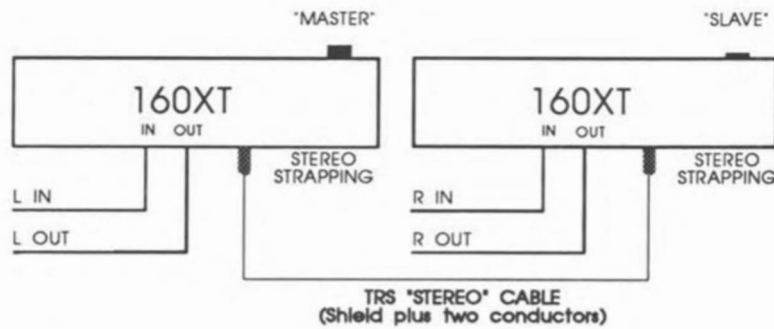

Figure 8: Multi Channel Connections

The 160XT can be "strapped" to another 160XT for 2-channel stereo operation. This will force one of the units (SLAVE) to track the other (MASTER) to preserve proper stereo imaging. A 1/4" stereo phone cable is required to connect the two 160XTs together.

To operate in stereo, designate one of the two units to be a "MASTER" (SLAVE button OUT) and switch the other unit to "SLAVE" mode (SLAVE button IN, SLAVE LED ON).

The master 160XT will now respond to the combined inputs of the 160XTs. The master's controls will adjust the amount and nature of the compression and the slave will track accurately.

When the SLAVE switches on both units are not depressed, the 160XTs operate completely independently.

The 1/4" strapping cable may be left in place when both 160XTs are to be used independently (i.e., both as MASTER).

12

## Special Connections (OPTIONAL)

dbx 160XT

### Using External Level Detector Inputs

To control the compressor by signals other than the audio input (via an auxiliary device), connect the auxiliary device's output to the 160XT's Detector Input jack, and feed the auxiliary device's input with the same signal fed to the 160XT's Signal Input (for example, using a delay to create "negative" attack times) (Figure 16).

In certain situations, the auxiliary device may need to be inserted in the signal path, not in the detector path. In such cases, signal is fed to the input of that device, and also to the detector input, and the auxiliary device's output is fed to the 160XT signal input (Figure 9).



Figure 9: Using the 160XT with a Sampler

# Basic Operation (Control Descriptions)

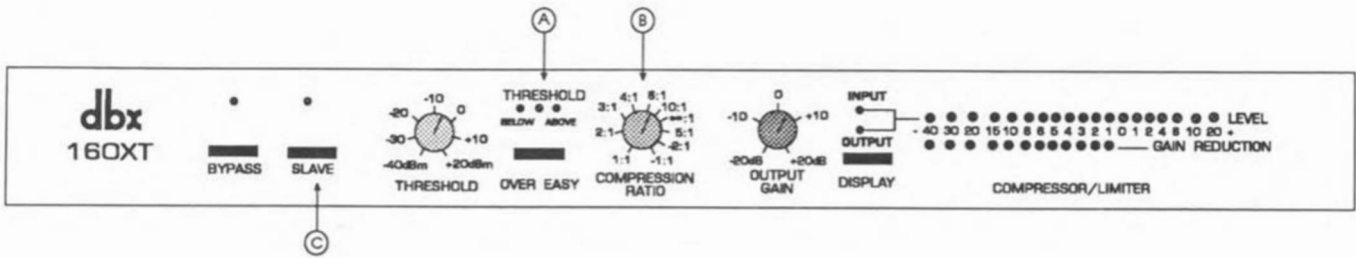

Figure 10: Front Panel

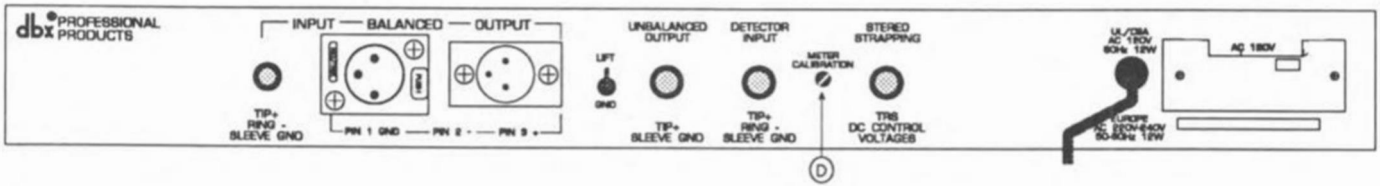

Figure 11: Rear Panel

# Basic Operation (Control Descriptions)

dbx 160XT

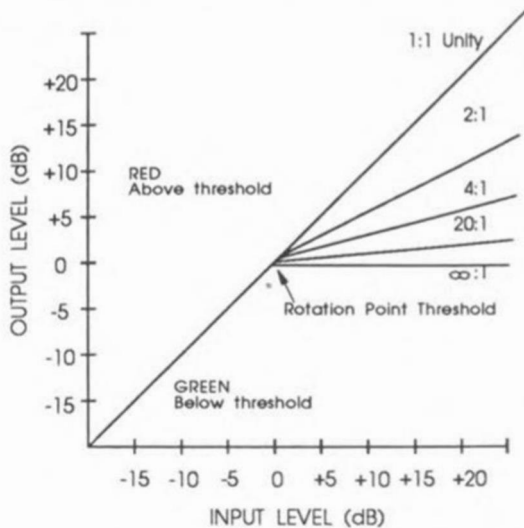

Figure 12: Hard-Knee Compression Curve

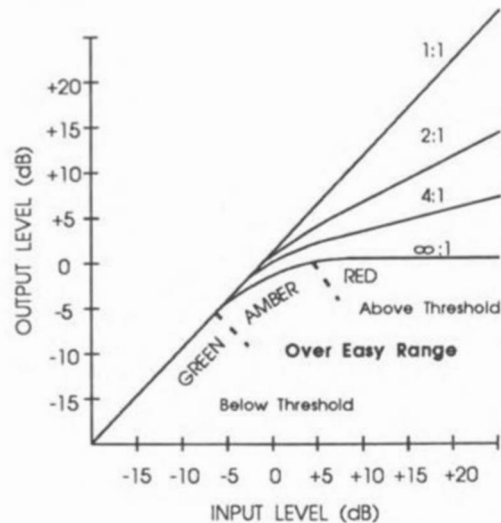

Figure 13: Threshold LEDs and Over Easy Compression Curve

A. **THRESHOLD control (and LED indicators):** In hard-knee mode this control sets a reference level above which input signals will be processed by the 160XT's gain change circuitry in the manner defined by the setting of the RATIO control. Input signals which fall below this level will pass through the 160XT unprocessed (except for fixed gain changes directed by the output control). See Figure 12.

In Over Easy Mode, signals begin to gradually activate the 160XT's gain change circuitry as they approach the THRESHOLD reference level and they do not get fully processed in the manner defined by the RATIO control until they have passed somewhat above the THRESHOLD reference level. In Over Easy mode there is no distinct point at which processing begins, and the THRESHOLD setting corresponds to a point on the input/output

## Basic Operation (Control Descriptions)

transfer curve midway between the onset of processing and that point at which the transfer curve corresponds to the setting of the RATIO control (Figure 13.13.). Figure 13. also shows how the 160XT's THRESHOLD indicator LEDs correlate with the compression curves.

**NOTE:** The THRESHOLD setting relates to the signal level seen by the DETECTOR input. In normal operation, the program input signal input is connected directly to the detector input. If this is not the case, the signal actually present at the detector input will determine how the 160XT processes the signal coming into its SIGNAL INPUT.

### B. COMPRESSION RATIO control:

When an input signal is above the THRESHOLD reference level, the setting of this control determines the number of decibels by which the input signal must change in level to produce a 1dB increase in the signal level at the output of the 160XT. A setting of 2:1 indicates an input:output ratio wherein a 2dB increase in signal (above threshold) will produce a 1dB increase in output signal. A setting of  $\infty$ :1 indicates that an infinite increase in input level would be required to raise the output level by 1dB.

The 160XT's RATIO control covers the entire range from 1:1 to  $\infty$ :1 and, in addition, goes to

Infinity+ (negative) ratios. At a setting of -1:1, the above threshold input signal must increase by 1dB in level to decrease the signal at the output of the 160XT by 1dB. See Figure 14.

The control curve of the RATIO potentiometer has been designed to provide total operator control, with scale expansion at the subtle lower ratios for easy, repeatable settings.

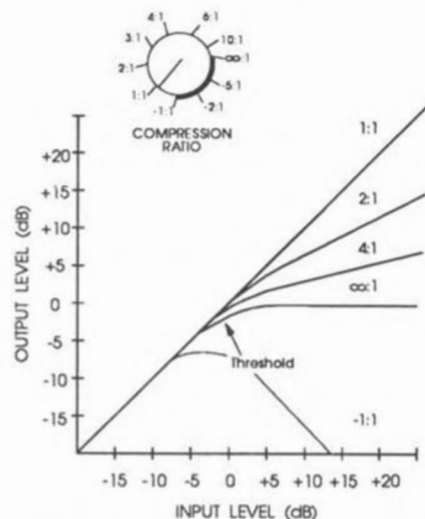

Figure 14: Ratio Control and Infinity+ (Negative) Ratios

16

## Basic Operation (Control Descriptions)

dbx 160XT

### C. SLAVE button (Stereo Operation):

Two channels of program material do not necessarily constitute a stereo program. A stereo program is one where the two channels are recorded and/or mixed to create the illusion of a single unified "panorama" of sound. The stability of the psychoacoustic "image" of each sound source within the stereo program depends upon its ability to maintain a specific phase and amplitude relationship from left to right channel.

If two independent compressors are used to process the stereo program, a loud sound occurring in one channel will cause a gain reduction only in that channel. This gain reduction would cause the perceived image of any sound spread between the two channels to move toward the side which had not been compressed, because the spread signal would be momentarily softer in the compressed channel. This can be avoided by linking the two compressors in such a way that both channels receive the same amount of compression. On the 160XT, this is accomplished by means of the STRAPPING jacks; a cable between these jacks permits the RMS detectors of both units to "talk" to one another—but only when one of the units' SLAVE buttons is depressed. The SLAVE unit then sends its signal to the MASTER, where the RMS power of the MASTER and SLAVE signals are combined to generate a control voltage. This control volt-

age is then used to compress both the MASTER and SLAVE units equally.

When compressing a stereo program with a pair of 160XTs, only the MASTER unit controls need to be adjusted.

### D. METER CALIBRATION control:

The INPUT/OUTPUT LEVEL DISPLAY in the 160XT is factory-calibrated to indicate "0" when the signal is +4dBu (1.23Vrms) at either the input or output of the 160XT, depending on the DISPLAY function switch position. (The METER CALIBRATION control does not affect the GAIN CHANGE LEDs.)

To recalibrate the LEVEL DISPLAY, depress the DISPLAY button to meter the INPUT LEVEL, and feed a 1kHz signal at the selected nominal operating level (the level desired for a "0dB" meter indication) to the 160XT's SIGNAL INPUT. Then adjust the rear panel METER CALIBRATION control until the meter indicates "0dB."

# Specific Applications

## Smoothing out variations in microphone levels

When the distance between a vocalist and a microphone changes, variations in signal level occur. To smooth out these variations, start with the 160XT adjusted for a low COMPRESSION RATIO (e.g., 4:1) and adjust the THRESHOLD control for optimum results, then increase COMPRESSION RATIO if necessary. Due to the gentle Over Easy characteristic of your 160XT you will find that even fairly high ratios are handled transparently.

## Smoothing out variations in musical instrument levels

To achieve a smoother electric bass sound, compress the instrument's output with a ratio of about 4:1 (the COMPRESSION RATIO control set at approximately 12:00). Compression lessens the loudness variations among the strings and increases the sustain. Other instruments, such as horns, vary in loudness depending on the note being played, and benefit similarly.

**NOTE:** When compressing a stereo program with a pair of 160XTs, the factors affecting a compression curve and the actual compression ratio and threshold settings, are like those previously covered with reference to single channels of program material. However, it will generally be found that large amounts of compression are more audible in a mixed stereo program than they might be

on the separate tracks that were mixed to create the program.

## Raising a signal out of a mix

Since reducing dynamic range increases the *average* signal level by a small amount, a single track can be raised out of a mix by boosting its level slightly and applying compression. It is also possible to separate certain vocals or instruments from a mono program already mixed by frequency-weighted compression (see page 20).

## Using your EQ to reduce feedback in live settings.

You can use your 160XT and EQ to reduce feedback in clubs or halls by placing the 160XT at  $\infty:1$ , Hard Knee, and a low threshold. Increase control gain until the first feedback "ring" occurs. The 160XT will catch it, and hold it as a constant tone so you can adjust your EQ to minimize it. Continue to increase your console gain and set your EQ until the 3 or 4 "ring" frequencies have been compensated for.

# Specific Applications

dbx 160XT

## Preventing tape saturation

With programs of widely varying levels, compression can prevent recording levels from saturating tape tracks (see Frequency-weighted compression, page 20).

## Speaker protection

Compressors are frequently used to prevent excessive program levels from damaging drivers in a sound-reinforcement system. Limiting also benefits intelligibility by allowing low-level input signals to be reproduced through the system at higher volume. In a musical performance, this provides additional intimacy as the vocalist's whispers are heard clearly at every seat in the house. The Over Easy curve available with the 160XT permits a very high amount of COMPRESSION (10:1 or greater) to be used in many situations. Vocalists and musicians don't get the sense of being held back, but high average levels can be maintained without speaker damage due to excessive heat buildup.

In circumstances where the 160XT is expected to cause no change in gain unless an emergency arises (wildly excessive levels) some operators set the COMPRESSION RATIO to  $\infty:1$ , the THRESHOLD to the highest permissible level, and operate the unit in hard-knee mode. As a general rule, the compressors should be *as close to the amplifiers as possible* in the signal chain. If the 160XT is placed before the EQ, for example, a potentially damaging

boost in EQ won't be seen by the 160XT and the speakers may be damaged. (see Multi-way speaker systems, page 12). For maximum sound pressure levels, large sound reinforcement systems frequently use a separate compressor on each output of the electronic crossover(s). For a stereo sound-reinforcement system, stereo strapping cables should be run between the 160XTs in each band (low-low, mid-mid, etc.).

## The 160XT as a line amplifier

To use the 160XT as a line amplifier, adjust the COMPRESSION ratio control to fully counterclockwise (1:1 position), THRESHOLD to full clockwise position (+10) and OUTPUT GAIN to whatever setting is required for the application. Remember that, as with any amplifier, excessive gain may lead to output clipping of high level signals. To add compression, adjust the COMPRESSION ratio and the THRESHOLD controls to the desired settings.

# Specific Applications

## Side-chain applications

### Frequency-weighted compression

It is possible to separate certain vocals and instruments from a mix by frequency-weighted compression. With an equalizer inserted ahead of the detector input (but not in the audio path), the equalization settings do not shift the timbre or frequency response of the audio signal. They merely alter the threshold response of the compressor on a "frequency-weighted" basis (see Figure 15).

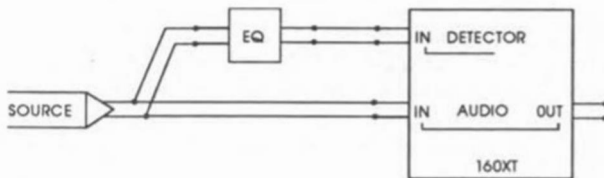

Figure 15: Frequency-Weighted Compression

With this arrangement, raising certain frequencies on the equalizer causes them to be suppressed in the audio signal. A relatively high THRESHOLD setting can allow normal sounds to be unaffected while solo and very loud sounds are held back. (Of course, when compression does occur, the level of the entire program is affected.) Depending on the THRESHOLD setting, lower level fundamentals or

harmonics will not cause compression, and the program is not subject to the phase shift normally caused by program equalization.

During the recording of cymbals and tom-toms, a compressor with an equalizer in the detector path can help prevent tape saturation. The equalizer can be adjusted for boost with a peak of about 5kHz, causing the cymbal to be compressed on a very loud crash, stopping tape saturation at high frequencies, where there is less headroom. However, gentle tapping of a drumstick or brushing of the cymbal will not be held back. Assuming the tom-tom is a lower frequency instrument and can be better tolerated by the tape, it has less need for compression. The equalization in the detector circuit means that the compressor is not triggered as readily by a loud tom-tom beat as by an equally loud cymbal crash.

The converse of the above EQ technique may be used: dipping the equalizer bands causes any sound with dominant energy in the affected register to pull the level up because the 160XT will detect a need for less compression.

20

# Specific Applications

dbx 160XT

## De-Essing

To apply de-essing to vocals (i.e., a reduction of sibilance), use a parametric equalizer in the level detector circuit and set it for high frequency boost in the specific frequency range where the vocal "hiss" or lisp occurs (generally in the 4-6kHz region). This pre-emphasizes the already "hissy" vocal input to the detector. Used in conjunction with a moderate to high threshold and compression ratio, this arrangement greatly attenuates the "essing" without affecting the basic sound quality or balance of the voice. While it is true that all frequencies are lowered in level when the compressor is triggered, generally the "sss" sound occurs alone, before or after the dominant tone in the voice.

## Increasing Sustain

To increase the sustain of a musical instrument (e.g., a guitar or bass), use an equalizer in the level detector circuit and boost the EQ in the dominant frequency range of the instrument, along with a fairly low threshold and a moderate compression ratio.

## Using a Filter in the Level Detector Circuit

The results of inserting a filter in the level detector circuit are basically the same as obtained with an equalizer, as previously described. Those frequencies passed by the filter are subject to compression (or at least they are subject to considerably

more compression than those frequencies outside the passband). Because a passive filter can have insertion loss, it may be necessary to lower the 160XT's THRESHOLD setting to maintain a given amount of gain reduction within the filter passband; this can be determined by monitoring the 160XT's threshold indicator LEDs.

## Multi-way speaker systems

If a single compressor is to be used with a multi-way speaker system (i.e., before the crossover, after EQ), the system operator is faced with the problem of keeping levels below the point of destruction of the most sensitive part of the system. If, for example, mid-range drivers are frequently damaged, the whole system must be operated at a lower sound-pressure level, or additional mid-range drivers must be added. By inserting an equalizer in the detector path to the 160XT, it can be made more sensitive to frequencies in the range handled by the sensitive drivers. The system can then be run at higher levels and will only be dropped back when damaging signals are present.

## Pre-emphasis for broadcast applications

By inserting a pre-emphasis filter network in the detector path of a 160XT processing pre-emphasized audio, higher levels can be run within the headroom limitations of the broadcast chain.

# Specific Applications

## Anticipated compression

By feeding the program directly to the 160XT's detector input and sending the audio signal through a delay line before the audio input, the unit can "anticipate" the need for a gain change. See Figure 16. With some experimentation the effect can be that of "zero" attack time at a given frequency. Additional signal delays beyond this "zero" time will then cause the compressor to finish reducing the gain before the leading edge of the loud passage even enters the signal input. This will suppress the program material preceding this loud passage. The 160XT will then begin to release (recover from compression) before the loud passage has dropped back down toward the set threshold. This will cause the output level to surge higher as the note or passage should be decaying. The produced effect sounds like reverse playback of a tape recording. When coupled with Infinity+ compression, highly unusual effects can be achieved.

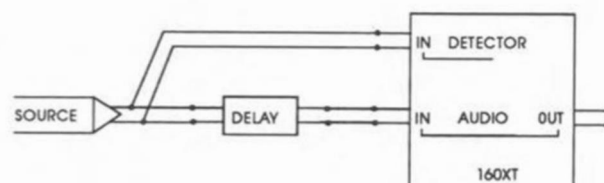

Figure 16: Anticipated Compression

22

## Installation Considerations

dbx 160XT

### Power Considerations

#### Connect Power

- A. Check the line voltage.

The 160XT is shipped for 115 or 230V, 50 or 60Hz operation. Refer to the unit's rear panel to verify your unit's precise line voltage.

- B. Connect the 160XT's power cord to an appropriate AC power source.

#### Mounting the 160XT in a Rack (OPTIONAL)

Mount the 160XT in a 1U rack space (1.75 inches, 4.45 cm).

Mounting the unit directly over large heat-producing devices (such as a vacuum-tube power amplifier) may shorten component life and is not recommended. Ambient temperatures should not exceed 113°F (45°C) when equipment is powered.



# Installation Considerations

## Input Cable Configurations

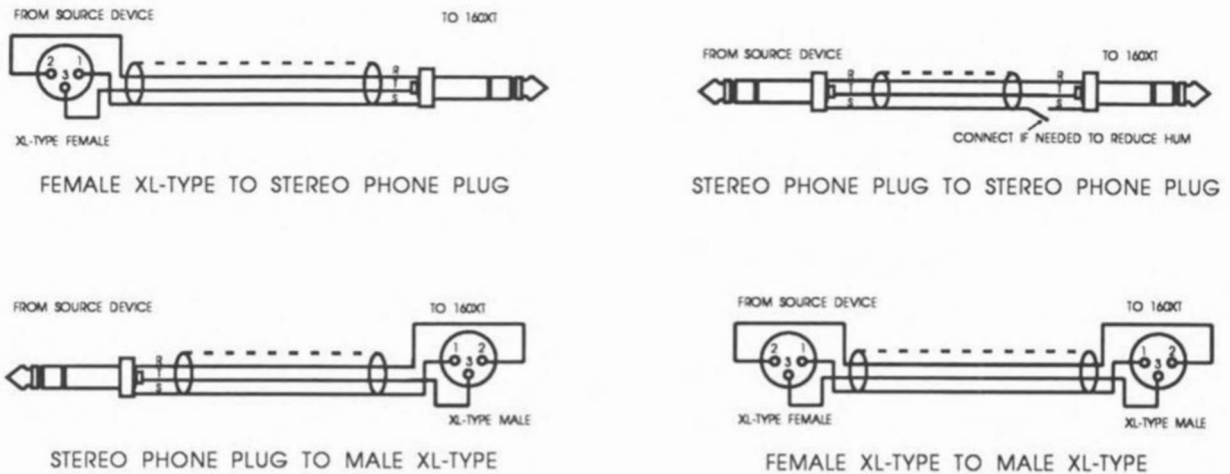

Figure 17: Input Connections (Balanced Lines)

### Connect Audio Inputs

The 160XT has an actual input impedance of 100kΩ in balanced configuration or 50kΩ if unbalanced. This makes the 160XT audio input suitable for use with virtually any source impedance, low or high. The 160XT's input connectors are wired in parallel. That is, the phone jack TIP (+) connection is internally wired to the XL-type pin 3, the RING (-) is wired to pin 2, and the SLEEVE (shield) is wired to pin 1. Note that pins 2 and 3 are the reverse of certain other manufacturer's equipment, but if the same connection is used at the output, the signal will be correctly polarized ("in phase").

24

# Installation Considerations

dbx 160XT

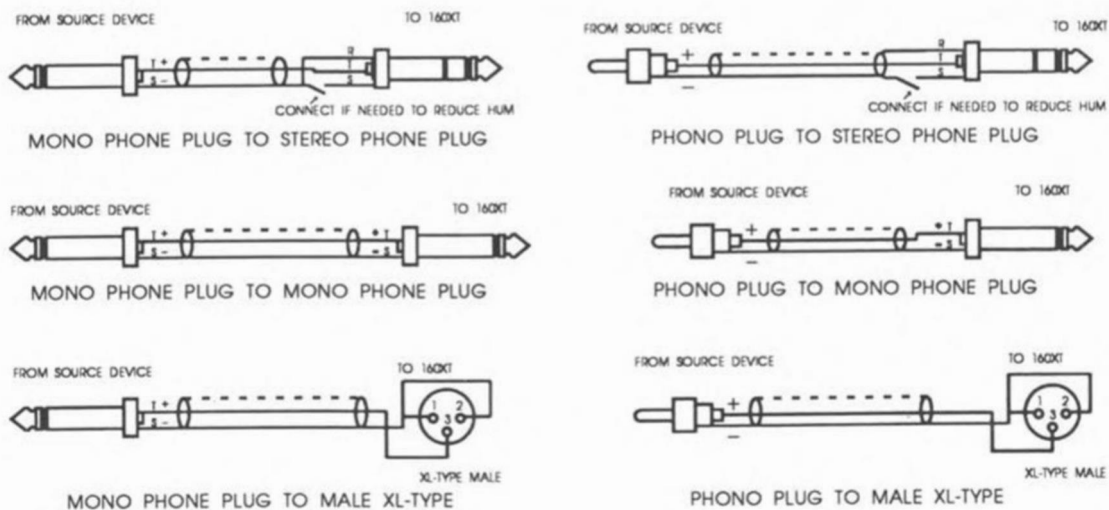

Figure 18: Input Connections (Unbalanced Lines)

Reversing the input wires to the input terminals will result in the output signal polarity being the opposite of the input signal ("180° out of phase").

The 160XT has a rear-panel GROUND LIFT switch. This switch disconnects the input XL-type pin 1 from the 160XT's circuit ground. This is to allow troubleshooting of hum and other grounding problems without having to change the cabling. We advise starting with the switch in the LIFT position (shield disconnected at the 160XT input).

# Installation Considerations

## Output Cable Considerations

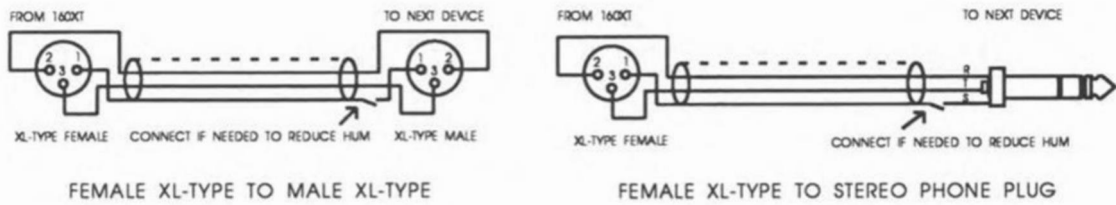

Figure 19: Output Connections (Balanced Lines)

### Connect Audio Outputs

The model 160XT has two separate outputs: one single-ended amplifier driving the 1/4" stereo phone jack, and a separate active-balanced amplifier driving the XL-type output connector. Each is capable of driving a 600 ohm load to +24dBu. The XL-type output (balanced) can be transformer-coupled by installing an optional output transformer inside your 160XT (see page 28).

26

# Installation Considerations

dbx 160XT

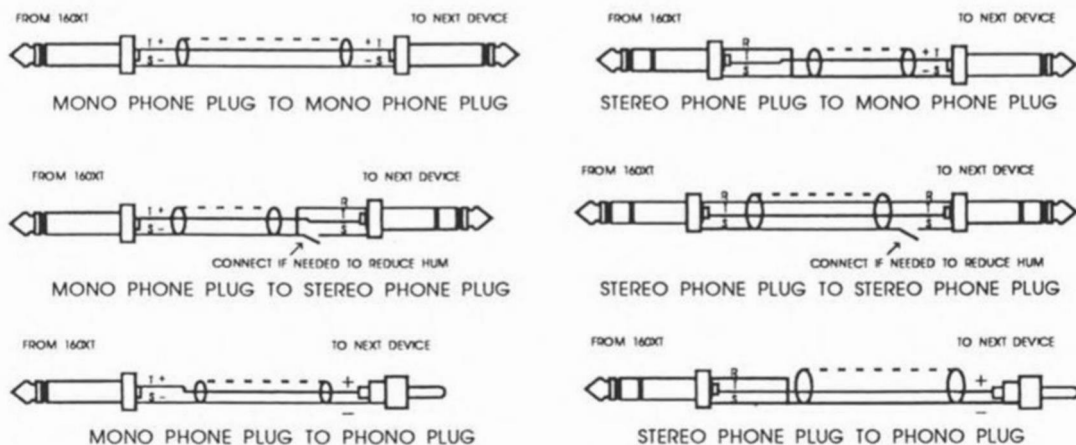

Figure 20: Output Connections (Unbalanced Lines)

# Installation Considerations

## Transformer Balanced (OPTIONAL)

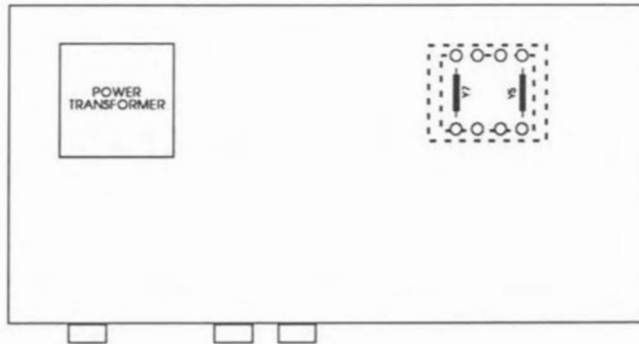

Figure 21: Transformer Mounting Area on 160XT Board

The 160XT main circuit board is drilled to accept an output transformer to provide a balanced, floating output stage. dbx recommends installing transformers only when an isolated output is needed. Compatible transformers are currently available from two sources:

Bauer Communications, Inc.  
6887 Farndale Ave., Bldg 12  
North Hollywood, CA 91605  
TEL (800) 627-7277  
or (818) 891-9983

Jensen Transformers  
10735 Burbank Boulevard  
North Hollywood, CA 91601  
TEL (213) 876-0059



- A. Unplug the 160XT from the AC Mains.
- B. To open the unit for access to the main circuit board, first remove the screws securing both rack ears, and set them aside.
- C. Next, remove the remaining screws, which secure the top cover to the chassis.

28

# Installation Considerations

dbx 160XT

- D. Referring to Figure 21, note the mounting location of the transformer on the 160XT circuit board. Within the transformer mounting area are two jumpers (Y5 and Y7). Cut or unsolder these jumpers.
- E. Insert the transformer from the top side of the board, pressing its pins firmly into the socket cups provided. These transformers are symmetrical (primary and secondary windings are identical), so orientation on the 160XT circuit board is not critical; if the pins line up, they are correctly installed.
- F. Reverse the disassembly procedure (Steps A and B) to attach the top cover and rack ears.
- G. The 160XT output is now balanced and floating, since there is no ground reference. We recommend you label the rear panel accordingly, indicating that a balanced, floating output is installed.

## Grounding

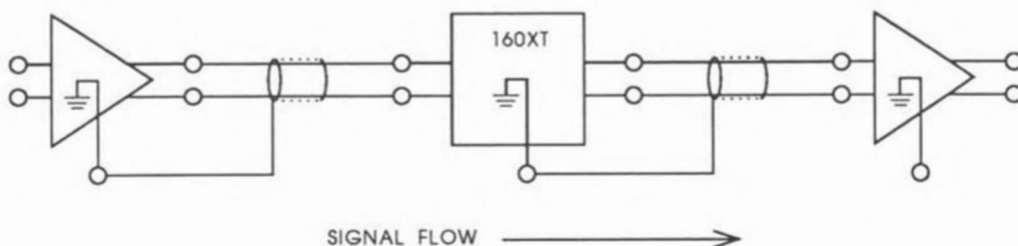

Figure 22: Signal Flow (Balanced Connection)

**NOTE:** For maximum hum rejection, avoid common grounding at the 160XT's input and output. The best starting point is to ground the shield of the input cable at the source device (leaving it unconnected at the 160XT) and to ground the shield of the output cable to the ground terminal of the 160XT (leaving it unconnected at the receiving device).

# Maintenance and Technical Support

## Maintenance and Troubleshooting

The 160XT is an all-solid-state product with components chosen for high performance and excellent reliability. Each 160XT is tested, burned in and calibrated at the factory and should require no adjustment of any type throughout the life of the unit. We recommend that your 160XT be returned to the factory should circumstances arise which necessitate repair or recalibration. The 160XT requires no special preventive maintenance.

## Technical Support

If you require technical support, contact dbx customer service. Be prepared to accurately describe the problem. Know the serial number of your 160XT — this is printed on a sticker attached to the rear panel.

Telephone: (1) 415/351-3500  
or Fax: (1) 415/351-0500  
or Telex: 17-1480

or Write: Customer Service  
dbx Professional Products  
a division of AKG Acoustics Inc.  
1525 Alvarado Street  
San Leandro, CA 94577 USA

## Factory Service

Always contact Customer Service before returning a product to the factory for service. Often, a problem is relatively simple and can be quickly fixed after telephone consultation.

Products can be returned to the factory for service *only* after Customer Service has issued a Return Authorization number. This number flags the returned unit for priority treatment when it arrives on our dock, and ties it to the appropriate information file.

Please refer to the terms of your Limited Two-Year Standard Warranty, which extends to the first end-user. After expiration of the warranty, a reasonable charge will be made for parts, labor, and packing if you choose to use the factory service facility. In all cases, you are responsible for transportation charges to the factory. dbx will pay return shipping if the unit is still under warranty.

# Maintenance and Technical Support

dbx 160XT

## Shipping Instructions

Use the original packing material if it is available or a sturdy, double-walled carton no smaller than 22 x 12 x 5 inches (55.75 x 31 x 13 cm). Place the unit in a plastic bag to protect it from moisture and to protect the finish, then pack it in the carton with at least 1.5 inches (3.75 cm) of cushioning on all sides of the unit. Use enough packing to prevent the module from moving during shipment. Seal the carton with 3-inch (7.6 cm) reinforced fiberglass or polyester sealing tape.

Mark the package with the name of the shipper, and with these words in red:

**DELICATE INSTRUMENT, FRAGILE!**

Insure the package properly. Ship prepaid, not collect. Do not ship parcel post.

# Specifications

## Input Characteristics

**Rear Panel Input Impedance:**  
Balanced = 100k $\Omega$  / Unbalanced = 50k $\Omega$

**Maximum Input Level:**  
+24dBu (12.3Vrms)

**Rear Panel Connector Type:**  
1/4" TRS Phone Jack and XL-type Connector

**Detector Input Impedance:**  
Balanced = 460k $\Omega$  / Unbalanced = 230k $\Omega$

**Maximum Detector Input Level:**  
+28dBu (19.5Vrms)

**Detector Connector Type:**  
1/4" TRS Phone Jack

## Output Characteristics

**Output Source Impedance:**  
Balanced, 22 $\Omega$ , XL / Unbalanced = 44 $\Omega$ , Phone

**Minimum Load Impedance:**  
Greater than or equal to 600 $\Omega$

**Maximum Output Level:**  
Balanced and Unbalanced, +24dBu (12.3Vrms)  
into 600 $\Omega$

**Connector Type:**  
1/4" TRS Phone Jack and XL-type Connector

## Performance Characteristics

**Frequency Response:**  
20Hz-20kHz ( $\pm$  0.5dB)

**THD Distortion:**  
<0.2%, Any amount of compression @ 1kHz

**IMD Distortion:**  
<0.2% SMPTE

**Equivalent Input Noise:**  
-89dBu

**Dynamic Range:**  
113dB

**Output Gain:**  
Variable from -20dB to +20dB

**Threshold:**  
Compressor -40dBu to +20dBu

**Threshold Characteristics**  
Selectable Over Easy<sup>®</sup> or Hard Knee

**Compression Ratio:**  
Variable 1:1 -  $\infty$ :1 thru to -1:1; >60dB Maximum  
Compression

**Attack Time:**  
Program-Dependent; 15ms for 10dB, 5ms for  
20dB, 3ms for 30dB

**Release Time:**  
Program-Dependent; 8ms for 1dB, 80ms for  
10dB, 400ms for 50dB; 125dB/sec Rate

32

# Specifications

dbx 160XT

## Controls, Indicators, Meters

**Controls:**  
Threshold Knob, Ratio Knob, Output Gain  
Knob, Over Easy/Hard Knee Switch, Slave  
Switch, Bypass Switch, Input/Output Switch

**Indicators:**  
Below: Green; Threshold: Yellow; Above: Red;  
Slave: Yellow; Bypass: Red; In/Output: Red

**Metering:**  
19 Segment LED Bargraph Display indicating  
Input/Output Level; 13 Segment LED Bar-  
graph Display indicating Gain Reduction

**Calibration:** Factory preset at 0VU = +4dBu  
(1.23Vrms); rear panel potentiometer sets  
0VU for any level from -10dBu (7.8mVrms) to  
+10dBu (2.45Vrms).

**Stereo Coupling:**  
True Power Summing; 1/4" TRS Phone Jack

## General

**Power Line Requirements:**  
90 - 130VAC, 50/60Hz, Switchable to 220 -  
240VAC

**Power Consumption:**  
12W

**Dimensions:**  
1.75" (H) x 19" (W) x 9.25" (D)

**Rack Space:**  
1 Rack Unit

**Weight:**  
6.5lbs/9lbs shipping weight

**Warranty:**  
Two-year, parts and labor: Subject to limita-  
tions set forth in our Standard Warranty. Fac-  
tory assistance and service will be available  
throughout the life of the product.

Specifications are subject to change.

# Schematic (160XT Main Board)

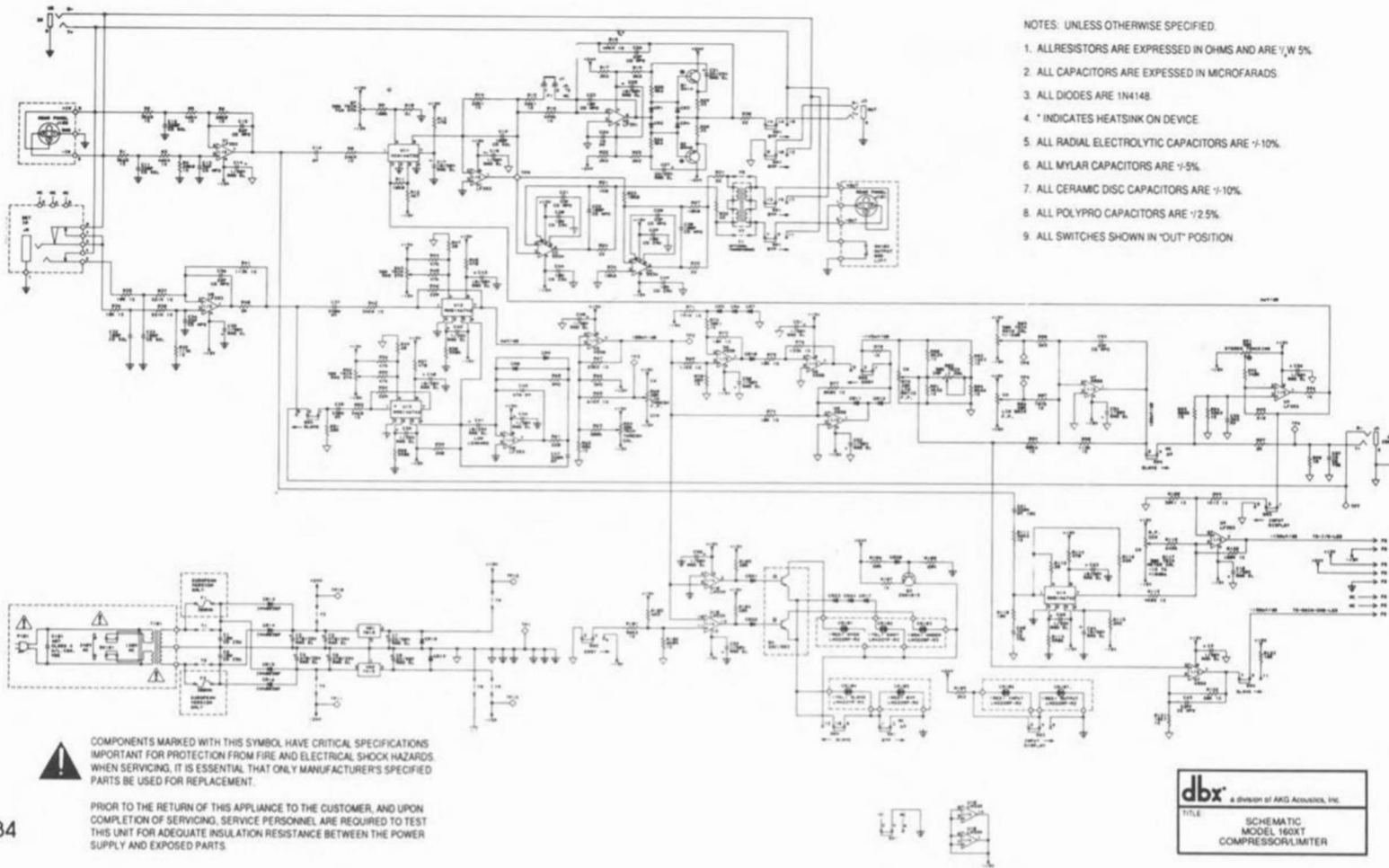

NOTES: UNLESS OTHERWISE SPECIFIED.

1. ALL RESISTORS ARE EXPRESSED IN OHMS AND ARE  $\pm 5\%$ .
2. ALL CAPACITORS ARE EXPRESSED IN MICROFARADS.
3. ALL DIODES ARE 1N4148.
4. \* INDICATES HEATSINK ON DEVICE.
5. ALL RADIAL ELECTROLYTIC CAPACITORS ARE  $\pm 10\%$ .
6. ALL MYLAR CAPACITORS ARE  $\pm 5\%$ .
7. ALL CERAMIC DISC CAPACITORS ARE  $\pm 10\%$ .
8. ALL POLYPRO CAPACITORS ARE  $\pm 2.5\%$ .
9. ALL SWITCHES SHOWN IN "OUT" POSITION.



COMPONENTS MARKED WITH THIS SYMBOL HAVE CRITICAL SPECIFICATIONS IMPORTANT FOR PROTECTION FROM FIRE AND ELECTRICAL SHOCK HAZARDS WHEN SERVICING. IT IS ESSENTIAL THAT ONLY MANUFACTURER'S SPECIFIED PARTS BE USED FOR REPLACEMENT.

PRIOR TO THE RETURN OF THIS APPLIANCE TO THE CUSTOMER, AND UPON COMPLETION OF SERVICING, SERVICE PERSONNEL ARE REQUIRED TO TEST THIS UNIT FOR ADEQUATE INSULATION RESISTANCE BETWEEN THE POWER SUPPLY AND EXPOSED PARTS.

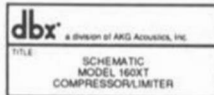

34

## Glossary

dbx 160XT

This section offers a brief discussion of concepts directly related to the 160XT's features and functions (e.g., Dynamic Range, Compression, Limiting, Threshold and Leveling) as well as other common audio concepts (e.g., Noise Reduction). Read this section if any of these concepts are new or unclear. Understanding the concepts behind the 160XT and other audio equipment will help you to get the most productivity for all your audio applications.

### Asperity Noise

This is a swishing type of background noise that occurs with tape recordings in the presence of strong low frequency signals to mask the hiss. Asperity noise is caused by minute imperfections in the surface of the tape, including variations on the magnetic particle size in the tape's oxide coating. The imperfections increase or decrease the strength of the magnetic field passing the play head in a random manner, resulting in audible noise. Asperity noise may be present even when no program is recorded. When a program is recorded, asperity noise becomes superimposed on a signal, creating modulated asperity noise, or "modulation noise." Using high-quality tape with a calendered surface helps reduce asperity and modulation noise (calendered tape is pressed smooth by high-pressure rollers).

### Attack Time

Attack time has different meanings in different contexts. In music, it is the time it takes for a note to reach its full volume is the attack time of the note. Percussive instruments usually have short attack times (reaching maximum volume quickly) and wind instruments tend to have long attack times (reaching maximum volume more gradually).

A compressor or expander requires a finite time to respond to changes in level. This time is known as attack time. More precisely, the attack time is the interval (usually measured in milliseconds, or microseconds) during which the compression or expander amplifier changes its gain from the initial value to 90% of the final value.

### Aux Input (Aux Level)

Aux inputs, an abbreviation for auxiliary inputs, are low sensitivity jacks provided on most hi-fi and semi-professional equipment. Aux inputs (also known as "aux level" or "line-level" inputs) have "flat" frequency response and are intended to be used with pre-amplified signals. Aux-level (line-level) signals are medium-level, higher than microphone levels, but not enough power to drive a speaker. The advantage to these levels is that they are less susceptible to hum and noise than are microphone levels. Typical items that might be connected to aux in-

35

puts are tape machine "play" outputs, tuner outputs, and dbx "play" outputs. Mic-level or phono-level signals are considerably lower in level than aux inputs (approx -60 to -40dBu), so they will not produce adequate volume when connected to an aux input. Moreover, phono cartridge outputs require RIAA equalization that is not provided by aux inputs.

### **Bandwidth**

Bandwidth refers to the "space" between two specific frequencies that are upper and lower limits; alternately, bandwidth refers to the absolute value of the range of frequencies between those limits. Thus, a filter that passes frequencies from 1kHz to 10kHz may be said to have a bandwidth of 1kHz - 10kHz, or it may be said to have a 9kHz bandwidth (10kHz minus 1kHz equals 9kHz).

Bandwidth is not necessarily the same as frequency response. Bandwidth may be measured at low levels, and frequency response at higher levels. Moreover, bandwidth may refer only to certain portions of the circuitry within a piece of equipment, whereas frequency response may refer to the overall performance of the equipment. Thus, while the overall input-to-output frequency response of dbx Type II equipment is 20Hz to 20kHz, the bandwidth of the RMS detection circuitry within that equipment is 60Hz to 10kHz.

### **Bass**

The low audio frequency range below approximately 500Hz. For the purpose of discussion or analysis, the bass range may be further divided into upper bass (250 to 500Hz), mid bass (100 to 200Hz), low bass (50 to 100Hz) and ultra-low bass (20 to 50Hz).

### **Bass Boost**

An accentuation of the lower audio frequencies (bass frequencies), whereby they are made louder than other frequencies.

### **Biamplified**

Descriptive of a sound system that utilizes a low level crossover network to divide the full-spectrum audio signal into low and high frequency ranges. These ranges are then fed to separate power amplifiers, which in turn feed low frequency speakers (woofers) and high frequency speakers (tweeters).

### **Bias**

Bias, as the term used in tape recording, is a very high frequency signal (usually over 100kHz) that is mixed with the program being recorded in order to achieve linear magnetization of the tape. If only the audio program were applied to the recording head, a very distorted recording would result because lower-energy portions of the program would not be able to overcome the initial magnetization threshold of the tape (known as hysteresis).

The frequency of the bias signal is approximately 4 times the highest frequency of the tape recorder's Record/Reproduce response. The bias energy level has a direct effect on recorded level, background noise and the distortion. For optimum performance, it is recommended that the tape recorder be calibrated each time a different tape type is used. Most, if not all professional tape recorder manufacturers feature bias presets to accommodate the different tape types. Many consumer tape machines offer bias select switches to optimize for most of the High bias cassette tapes available today.

### **Clipping**

Clipping is a very distorted sound. It occurs when the output capabilities of an amplifier are exceeded, and the amplifier can no longer produce anymore voltage, regardless of how much additional gain or how much more input signal is present. Clipping is relatively easy to see on an oscilloscope, and is sometimes audible as an increase in harmonic distortion. In severe cases of clipping (hard clipping), sine waves begin to resemble square waves, and the sound quality is very poor. Often, the maximum output level of an amplifier is defined as that level where clipping begins to occur. There is a phenomenon known as input clipping, and this may occur where the input signal is so high in level that it exceeds the level-handling ability of the

transformer and/or of the input amplifier. Clipping also occurs when tape is saturated by excessive record levels.

So-called "soft clipping" is usually the result of transformer saturation, and it may be somewhat less objectionable than the "hard clipping" that occurs when output voltage limits are reached. Aside from degrading the sound quality, clipping can damage loud speakers. Output clipping can be avoided by reducing the level of the input signal, reducing the gain of the amplifier, or using a larger amplifier. Input clipping may be avoided by reducing the input level.

### **Clipping Level**

This is the signal level at which clipping just begins to occur. Clipping level is not always easy to define. It may be a matter of visually judging the waveform on an oscilloscope as the level is increased; alternately, clipping may be defined as the level at which harmonic distortion reaches a given value. Tape clipping, or saturation, is defined as the 3% harmonic distortion level.

### **Compression**

Compression is a process whereby the dynamic range of program material is reduced. In other words, the difference between the lowest and highest audio levels is "squeezed" into a

smaller dynamic range. A compressed signal has higher average level, and therefore may have more apparent loudness than an uncompressed signal, even though the peaks are no higher in level. Compression is achieved with a compressor, a special type of amplifier that decreases its gain as the level of the input signal increases. The amount of compression is expressed as a ratio of the input dynamic range to the output dynamic range; thus, a compressor that takes a program input with 100dB of dynamic range and yields an output program of 50dB dynamic range may be said to have a 2:1 compression ratio.

## Compressor

A compressor is an amplifier that decreases its gain as the level of the input signal increase to reduce the dynamic range of the program (see "Compression"). A compressor may operate over the entire range of input levels, or it may operate only on signals above and/or below a given level (the threshold level).

## Crossover Frequency

In loudspeaker systems and multi-amplifier audio systems, the transition frequency (actually a frequency range) between bass and mid-range or midrange and treble speakers or amplifiers.

## Crossover Network

A circuit that divides the audio spectrum into two or more frequency bands for distribution to different speakers (high level crossover) or different amplifiers that then feed different speakers (low level crossover).

High level crossovers are usually built into the speaker cabinet, and are passive (they require no power supply). Low level crossovers are used in bi-amplified or tri-amplified sound systems. They are usually self-contained, and come before the power amplifiers. Low level crossovers may be passive or active; active low level crossovers are known as "electronic crossovers."

## Damping Factor

The ratio of loudspeaker impedance to the amplifier's output source impedance. Damping describes the amplifier's ability to prevent unwanted, residual speaker movement. The higher the numerical value, the better the damping.

## dB (Decibel) also dBv, dBV, dB SPL, dBu, dBm, dB

One dB is the smallest change in loudness the average human ear can detect. 0dB SPL is the threshold of human hearing, whereas the threshold of pain is between 120 and 130dB SPL. The term dB is an abbreviation for decibel,

or  $\frac{1}{10}$  of a Bel. The decibel is a ratio, not an absolute number, and is used to express the difference between two power, voltage or sound pressure levels. (dB is 10 times the logarithm of a power ratio or 20 times the logarithm of a voltage or sound pressure ratio.) If the number of "dBs" are referenced to a given level, then the value of the dB number becomes specific:

dBu expresses a voltage ratio. 0dBu is usually referenced to 0.775Vrms. Thus, 0dBu = 0.775V, +6dBu = 1.55V (twice 0dBu), +20dBu = 7.75V (ten times 0dBu), etc.

dBv expresses a voltage ratio that is often used interchangeably with dBu.

dBV expresses a voltage ratio and is similar to dBu, but 0dBV is usually referenced to 1Vrms. Thus 0dBV is 2.22dB higher than 0dBu.

dB SPL expresses a Sound Pressure Level ratio. dB SPL is a measure of acoustic pressure (loudness), not acoustic power, that would be measured in acoustic watts. 0dB SPL is equal to 0.0002 dynes/square centimeter (the threshold of human hearing at 1kHz). As with dBV, an increase of 6dB SPL is twice the sound pressure, and increase of 20dB SPL is an increase of 10 times the sound pressure.

dBm expresses a power ratio. 0dBm is 1 milliwatt (.001 watts), or 0.775Vrms delivered to a 600-ohm load. +3dBm = 2 milliwatts, or 1.55V into 600 ohms (twice 0dBm), +20dBm = 100 milliwatts, or 7.75V into 600 ohms (ten times 0dBm), etc. dBu and dBm are numerically equal when dealing with 600-ohm circuits. However, when the impedance is other than 600 ohms, the value of dBu remains the same if the voltage is the same, whereas the value of dBm decreases with increasing impedance.

dB alone, without any suffix, doesn't mean anything unless it is associated with a reference. It may express the difference between two levels. Thus, the difference between 10dBV and 15dBV, the difference between 0dBm and 5dBm, and the difference between 90dB SPL and 95dB SPL are all differences of 5dB.

## Decay Time

Decay time has different meanings in different contexts. A compressor's decay time is also known as its release time or recovery time. After a compressor (or expander) changes its gain to accommodate an incoming signal, and the signal is then removed, the decay time is the amount of time required for the circuitry to return to "normal." More precisely, the decay time is the interval (usually measured in microseconds) during which the compressing or ex-

panding amplifier returns to 90% of the normal gain. Very fast decay times can cause "pumping" or "breathing" effects, whereas very slow decay times may cause moderate-level program that follows high-level program or program peaks to be too low in level.

## Decoder

When a circuit restores an original program from a specially treated version of that program, the circuit may be said to decode the program. The equipment or circuit which performs this function is known as a decoder. Decoders must only be used with programs which have been encoded by complimentary encoding circuitry. Typical decoders include: FM tuners that use multiplex decoders to extract left and right stereo signals from left-plus-right and left-minus-right signals, matrix quadraphonic decoders that extract four channels of program from the stereo program on encoded recordings, and dbx decoders that retrieve wide-dynamic range programs from the compressed programs on dbx-encoded recordings.

## De-emphasis and Pre-emphasis

De-emphasis and pre-emphasis are related processes that are usually done to avoid audio noise in some storage or transmission medium. Pre-emphasis is a boost at specific higher frequencies, the encoding part of an encoding/decoding system. De-emphasis is an attenuation

at the same frequencies, a reciprocal decoding that counteracts the pre-emphasis. In dbx noise reduction, de-emphasis is performed by the decoder (the play circuitry). The de-emphasis attenuates high frequencies, thereby reducing tape modulation noise and restoring the original frequency response of the program before it was dbx encoded. There are other types of pre-emphasis and de-emphasis. For example, in FM tuners, de-emphasis is used to compensate for special equalization (known as 75-microsecond pre-emphasis) applied at the station's transmitter.

## Dynamic Range

The ratio between the loudest (greatest amplitude) signals and the softest (least amplitude) signals that either are contained in a certain piece of music or can be reproduced accurately by a certain piece of equipment. Dynamic range is normally expressed in decibels (dB) where each ratio of ten in power corresponds to a dynamic range of 10dB (e.g. a ratio of 100 in power corresponds to a dynamic range of 20dB, a ratio of 1000 in power corresponds to a dynamic range of 30dB). A program with wide dynamic range has a large variation from the softest to the loudest passages, and will tend to be more life-like than programs with narrow dynamic range.

# Glossary

## Encoder

When a circuit processes an original program to create a specially treated version of that program; the circuit may be said to encode the program. The equipment or circuit which performs this function is known as an encoder. Encoded programs must be decoded only with complementary decoding circuitry. Typical encoded programs include: FM multiple broadcasts, matrix quadraphonic recordings, and dbx encoded recordings.

## Envelope

In music, the envelope of a note describes the change in average signal level from initial attack, to peak level, to decay time, to sustain, to release time. In other words, the envelope describes the level of the note as a function of time. Envelope does not refer to frequency.

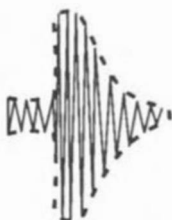

In fact, any audio signal may be said to have an envelope. While all audio frequencies rise and fall in instantaneous level from 40 to 40,000 times per second, an envelope may take many

milliseconds, seconds, or even minutes to rise and fall. In dbx processing, the envelope is what "cues" the rms level detection circuitry to compress and expand the signal; the peak or average level of individual cycles of a note would be useless for level detection because the gain would change much too rapidly for audibly pleasing sound reproduction.

## EQ (Equalization)

EQ or equalization, is an intentional change in the frequency response of a circuit. EQ may be used for boosting (increasing) or cutting (decreasing) the relative level of a portion of the audible spectrum. Some EQ is used for achieving sound to suit personal listening tastes, while other types of EQ are specifically designed to correct for non-linearities in the system; these corrective EQ "curves" include tape (NAB or CCIR) equalization, and phonograph (RIAA) equalization. In a sense, the pre-emphasis and de-emphasis used in dbx processing are special forms of equalization.

EQ is performed by an equalizer, which may be a specially built piece of equipment, or it may be no more than the tone control section of an amplifier. Graphic equalizers have many controls, each affecting one octave, one-half octave, or one-third octave of the audio spectrum. (An octave is the interval between a given tone and its repetition eight tones above or below on the

musical scale; a note which is an octave higher than another note is twice the frequency of the first note.

## Expander

An expander is an amplifier that increases its gain as the level of the input signal increases, a characteristic that "stretches" the dynamic range of the program (see "expansion"). An expander may operate over the entire range of input levels, or it may operate only on signals above and/or below a given level (the threshold level).

## Expansion

Expansion is a process whereby the dynamic range of program material is increased. In other words, the difference between the lowest and highest audio level is "stretched" into a wider dynamic range. Expansion is sometimes used to restore dynamic range that has been lost through compression or limiting done in the original recording or broadcast; expansion is an integral part of compander-type noise reduction systems, including dbx. Expansion is achieved with an expander, a special type of amplifier that increases its gain as the level of the input signal increases. The amount of expansion is expressed as a ratio of the input dynamic range to the output dynamic range; thus, an expander that takes a program input with 50dB of dynamic range and yields an output

program of 100dB dynamic range may be said to have a 1:2 compression ratio.

## Fundamental

A musical note is usually comprised of a basic frequency, plus one or more whole-number multiples of that frequency. The basic frequency is known as the fundamental, and the multiples are known as the harmonics or overtones. A pure tone would consist of only the fundamental.

## Gain Reduction Display:

Indicator of current amount of compression or limiting. On the 160XT, this display is a 12 segment LED display.

## Ground Compensated Output

This is a sophisticated output circuit that senses the potential difference between the ground of the dbx unit and the shield ground of unbalanced inputs to which the dbx unit is connected. Ideally, the dbx unit and the input of the following device should be at the same level (potential). However, where grounding is not "right" (where so-called "ground loops" exist), the circuit calculates the ground error and adds a correction signal to the high side of the output, thereby cancelling much of the hum, buzz and noise that might otherwise have been introduced by ground loops.

## Harmonic Distortion

Harmonic distortion consists of signal components appearing at the output of an amplifier or other circuit that were not present in the input signal, and that are whole-number multiples (harmonics) of the input signal. For example, an amplifier given a pure sine-wave input at 100Hz may produce 200Hz, 300Hz, 400Hz, 500Hz, 600Hz and even 700Hz energy, plus 100Hz, at its output (these being the 2nd, 3rd, 4th, 5th, 6th and 7th order harmonics).

Usually, only the first few harmonics are significant, and even-order harmonics (i.e., 2nd and 4th) are less objectionable than odd-order harmonics (i.e., 3rd and 5th); higher harmonics may be negligible in comparison to the fundamental (100Hz) output. Therefore, rather than specifying the level of each harmonic component, the distortion is usually expressed as T.H.D., or Total Harmonic Distortion. While T.H.D. is the total power of all harmonics generated by the circuitry, expressed as a percentage of the total output power, the "mixture" of different harmonics may vary in different equipment with the same T.H.D. rating.

## "Hard Knee" Compression

"Hard Knee" compression refers to the compression characteristic curve of a compressor. When a signal crosses the threshold, the compression circuitry responds to the signal almost

instantaneously, creating an abrupt level change at the audio output. This type of compression is most desirable for speaker protection, transmitter protection from overmodulation and protection from saturation on digital or analog tape recorders and producing popular instrument "sounds" (particularly drums)..

## Harmonics

Overtone which are integral multiples of the fundamental.

## Headroom

Headroom refers to the "space," usually expressed in dB, between the nominal operating signal level and the maximum signal level. The input headroom of a circuit that is meant to accept nominal -10dB levels, but can accept up to +18dB (from -10dB to +18 equals 28dB). Similarly, the output headroom of a circuit that is meant to supply nominal +4dBm drive levels, but that can produce +24dBm before clipping is 20dB. A circuit that lacks adequate headroom is more likely to distort by clipping transient peaks, since these peaks can be 10 to 20dB above nominal operating levels.

## IM (Intermodulation Distortion)

Intermodulation distortion consists of signal components appearing at the output of an amplifier or other circuit that were not present in the input signal, that are not harmonically related to the input, and that are the result of in-

teraction between two or more input frequencies. IM distortion, like harmonic distortion, is usually rated as a percentage of the total output power of the device. While some types of harmonic distortion are musical, and not particularly objectionable, most IM distortion is unpleasant to the ear.

### **Impulse Response**

Related to the rise time of a circuit, the impulse response is a measurement of the ability of a circuit to respond to sharp sounds, such as percussion instruments or plucked strings. A circuit with good impulse response would tend to have good transient response.

### **Leveling**

The process of taking a passage that varies in loudness and using a compressor to even out the sound. For instance, if a bass guitar has a few notes that for some reason resonate louder than others, the compressor will knock them down a bit. If the ratio is set to infinity, it will try to make all the notes exactly the same level, as long as they are above threshold. Leveling requires careful adjustment of the threshold and compression ratio, and usually requires adjustment of the output gain to compensate for overall level changes produced by the compression.

### **Level Match**

The dbx noise reduction system is unlike competitive systems in that there is no one thresh-

old at which compression or expansion begins. Instead, compression occurs linearly, with respect to decibels, over the full dynamic range of the program. By necessity, there is an arbitrary signal level which passes through the encoder and decoder without being changed in level. This level is known as the level match point (transient point). Some dbx equipment provides for user-adjustment of the level match point, for monitoring purposes only. Although this not necessary for proper encode/decode performance, by setting the level match point to be approximately equal to the nominal (average) signal level, there will be no increase or decrease in level as you switch from monitoring "live" program to monitoring dbx-processed program.

### **Limiter**

A limiter is a type of compressor, one with a infinity:1 or greater compression ratio. A limiter with a high compression ratio (120:1) can be set so that no amount of increase in the input signal will be able to raise the output level beyond a preset value. The difference between limiting and compression is that compression gently "shrinks" dynamic range, whereas limiting is a way to place a fixed "ceiling" on maximum level, without changing the dynamic range of program below that "ceiling" of threshold.

# Glossary

dbx 160XT

### **Limiting**

A specific type of compression where the program output level of the audio signal is kept at or below some absolute level (see Threshold). Generally, limiting occurs with compression ratios of 10:1 or greater.

### **Line Level (Line Input)**

Line level refers to a preamplified audio signal, in contrast to mic level, which describes a lower-level audio signal. The actual signal levels vary. Generally, mic level is nominally -50dBu (with typical dynamic range -64dBu to +10dBu). Line level signals vary, depending on the audio system. Semi-pro line levels are nominally -10dBu, whereas professional line levels are nominally +4dBu or +8dBu (with typical dynamics ranging from -50dBu to +24dBu).

Line inputs are simply inputs that have sensitivities intended for line level (preamplified) signals. Often, the nominal impedance of a line level input will be different than the nominal impedance of a mic level input.

### **Modulation Noise**

Modulation noise is a swishing type of background hiss that occurs with tape recordings in the presence of strong low frequency signals. The noise depends on the level of the recorded signal; the higher the recorded signal level, the higher the modulation noise. Modulation noise

has typically been "masked," hidden by the dominant signal and/or by the background hiss of the tape. However, when the background hiss is removed, as with dbx processing, modulation noise could become audible. This would happen primarily with strong, low frequency signals, but in fact it is minimized by dbx's pre-emphasis and de-emphasis. See Asperity Noise.

### **Octave**

In music or audio, an interval between two frequencies having a ratio of 2:1; 20Hz, 40Hz, 80Hz are said to be octaves of each other.

### **Output Gain**

Control for increasing or decreasing the program level. In the 160XT, the gain control is located after the compressor, so the output gain does not affect the amount of compression or the dynamic range. For example, when a fixed amount of gain is added at the output of a compressor, like the 160XT, the level of the loudest passages can be restored, and the soft passages will be brought up to a level greater than before the compression.

### **Over Easy® Compression**

dbx Over Easy compression permits extremely smooth, almost inaudible compression due to the gradual change of compression ratio around the threshold, instead of the customary sharp (Hard-Knee) threshold.

## Overshoot

When a compressor or expander changes its gain in response to a fast increase or decrease in level, the maximum gain change should be directly proportional to the actual signal level. However, in some compressors the level detection and gain changing circuitry develop a kind of "inertia," over-reacting to changes in level, increasing or decreasing the gain more than the fixed ratio asked for. This over-reaction is known as overshoot, and it can cause audibly non-linear compression (distortion). dbx circuits have minimal overshoot, so they provide highly linear compression and expansion.

## Peak Level

An audio signal continuously varies in level (strength, or maximum voltage) over any period of time, but at any instant, the level may be higher or lower than the average. The maximum instantaneous value reached by a signal is its peak level (see RMS level).

## Phase Inversion

"Phase inversion" refers to the swapping of polarity. This use of the term "phase," refers to the polarity of the signal and differs from the definition of phase shift below.

## Phase Shift

"Time shift" is another way to describe phase shift. Some circuitry, such as record electronics and heads, will delay some frequencies of an

audio program with respect to other portions of the same program. In other words, phase shift increases or decreases the delay time as the frequency increases. On an absolute basis, phase shift cannot be heard, but when two signals are compared to one another, one having a phase shift relative to the other, the effects can be very noticeable, and not very desirable. Excessive phase shift can give a tunnel-like quality to the sound. Phase shift also can degrade the performance of compander type noise reduction systems which depend on peak or average level detection circuitry.

## Power Amplifier

A unit that takes a medium-level signal (e.g., from a preamplifier) and amplifies it so it can drive a loudspeaker. Power amplifiers can operate into very low impedance loads (4-16 ohms), whereas preamplifiers operate only into high impedance (600 ohms) or low impedance (5,000 ohms or higher loads). Also known as a main amplifier, the power amplifier may be built into an integrated amplifier or a receiver.

## Preamplifier

A device which takes a small signal (e.g., from a microphone, record player), or a medium-level signal (e.g., from a tuner or tape recorder), and amplifies it or routes it so it can drive a power amplifier. Most preamplifiers incorporate tone and volume controls. A preamp may

# Glossary

dbx 160XT

be a separate component, or part of an integrated amplifier or receiver.

## Pre-emphasis

(See De-emphasis)

## Receiver

A single unit that combines tuner, preamp and power amplifier sections.

## Release Time or Release Rate

(See Decay Time and Attack Time)

## Rise Time (Attack Time)

This is the ability of a circuit to follow (or "track") a sudden increase in signal level. The shorter the rise time, the better the frequency response. Rise time is usually specified as the interval (in microseconds) required to respond to the leading edge of a square-wave input.

## RMS Level

RMS level (Root Mean Square) is a measurement obtained by mathematically squaring all the instantaneous voltages along the waveform, adding the squared values together, and taking the square root of that number. For simple sine waves, the RMS value is approximately 0.707 times the peak value, but for complex audio signals, RMS value is more difficult to calculate. RMS level is similar to average level, although not identical (Average level is a slower measurement).

## RMS Level Detector

In the dbx 160XT, the RMS level detector senses the power in the program in a musical manner, much as the ear does, giving results superior to peak or average detection.

## Sub Harmonic

A sub-multiple of the fundamental frequency. For example, a wave the frequency of which is half the fundamental frequency of another wave is called the second sub harmonic of that wave.

## Sub Woofer

A loudspeaker made specifically to reproduce the lowest of audio frequencies, usually between 20Hz and 100Hz.

## Synthesizer

An Electronic Music Synthesizer is an audio processor that has a built-in sound generator (oscillator) and that alters the envelope of the sound with voltage controlled circuitry. Synthesizers can produce familiar sounds and serve as musical instruments, or they can create many unique sounds and effects of their own. A sub-harmonic Synthesizer is a device which is not used to create music, but to enhance an existing audio program. It creates a new signal that corresponds to the input signal, but is  $\frac{1}{2}$  the frequency.

## Tape Saturation

There is a maximum amount of energy that can be recorded on any given type of magnetic tape. When a recorder "tries" to record more energy, the signals become distorted, but are not recorded at any higher levels. This phenomenon is called tape saturation because the magnetic oxide particles of the tape are literally saturated with energy and cannot accept any more magnetization.

**THD (Total Harmonic Distortion)**  
(See Harmonic Distortion)

## Threshold

Threshold is the level at which a compressor or limiter ceases to have linear gain, and begins to perform its gain-changing function (i.e., where the output level no longer rises and falls in direct proportion to the input level). In most systems, the threshold is a point above which the level changes, although there are compressors that raise signal levels below a threshold point. Some compander-type noise reduction systems, such as Dolby®, have upper and lower threshold between which the gain changes; these systems require careful level calibration for proper encode/decode performance. dbx noise reduction systems have no threshold at which compression or expansion factors change, so level calibration is not critical.

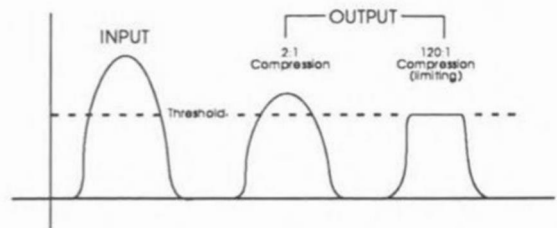

**Threshold and Compression Ratio Settings (How they define compression and limiting):** When the level of an audio signal is at or below threshold, the input and output levels will be unchanged. Above threshold, compression occurs at a level defined by the COMPRESSION ratio setting. If the ratio is 2:1, then when an above-threshold input goes up 10dB, the output will go up 5dB. When the input goes down 10dB, the output will go down 5dB (unless it goes below threshold). If a signal with a dynamic range of 60dB is put through a 2:1 compressor, the dynamic range of the output signal will be 30dB. If the ratio is infinity:1, the output level is constant regardless of the input level, once the input signal exceeds the selected threshold. A compression ratio of above 10:1 is commonly called limiting.

## Tracking Accuracy

Tracking refers to the ability of one circuit to "follow" the changes of another circuit. When two volume controls are adjusted in exactly the same way, the corresponding "sameness" of the output levels can be expressed as the tracking accuracy of the controls.

The level detection circuitry in a dbx encoder senses the signal level, changes the gain, and creates an encoded signal. The corresponding "sameness" of the original signal and the encoded/decoded signal can be expressed as the tracking accuracy of the noise reduction system. (dbx systems are non-critical for the operator, and are built to close tolerances, so that tracking accuracy is excellent, even if the encoder and decoder are in different pieces of dbx equipment.)

## Transition Level (see Level Match)

When a circuit has uniform compression or expansion throughout its full dynamic range, there must be some level which passes through the unit without being raised or lowered (where gain is unity). The unity gain level is the transition level or transition point. The transition point is a "window" 1dB wide. In a dbx encoder (compressor), all signals above the transition point are lowered in level, and all signals below the point are raised in level. Conversely, in a dbx decoder (expander), all signals

above the transition point are increased in level, and all signals below the point are decreased in level. The transition level is similar to a "threshold," except it does not refer to a point at which compression or expansion factors change.

## Triamplified

Similar to biamplified. A sound system where a crossover network creates three frequency ranges, and feeds three power amplifiers: one for bass, one for mid, and one for high frequencies. The amplifiers are connected directly to the woofers, midrange drivers and tweeters without a passive, high-level crossover network.

## Tweeter

A loudspeaker which reproduces only high frequencies, usually from 8kHz up to 20kHz.

## VCA (Voltage-Controlled Amplifier)

Traditionally, amplifiers have been designed to increase signal levels (to provide gain). If an amplifier were required to decrease the level (to attenuate), it could become unstable, and might even oscillate. The gain (amount of amplification) of these traditional amplifiers would be adjusted by one of three methods: (1) attenuating the audio signal fed to the input of the amplifier, (2) attenuating the audio output of the amplifier, or (3) changing the negative feedback (feeding more or less signal from the output

back to the input, but in reversed polarity).

The VCA is a special type of amplifier that can be used to increase or decrease levels over a wide dynamic range. Instead of using signal attenuation or negative feedback, the gain (or loss) is adjusted by means of an external DC control voltage. dbx has a unique, patented VCA design that has extremely low noise and very wide dynamic range; the dbx VCA is the heart of many dbx processors and is used widely by professional console manufacturers.

### **Woofers**

A loudspeaker which reproduces only low frequencies.

50

## Registration, Warranty, User-Feedback

dbx 160XT

### **Registration Card**

There are two good reasons for returning the Registration Card shipped with this product.

- 1) It enables us to inform you of new applications, performance improvements, and service aids that are developed, and
- 2) It helps us respond promptly to claims under warranty without having to request a copy of your bill of sale or other proof of purchase.

Please fill in the Registration Card, detach it from the Warranty Certificate, and send the card to us today. If it is lost, please photocopy the duplicate on the following page, fill it in, and send it to the address on the inside of the front cover.

### **Warranty**

The warranty, which can be enjoyed only by the first end-user of record, is stated on the separate Warranty Certificate packed with this manual. Save it for future reference. Details on obtaining factory service are provided on page 30.

### **User-Feedback Form**

We are very interested in your comments about this product.

Your suggestions for improvement to either the product or the manual will be welcome. A postpaid User Feedback Form is provided in the 160XT package for your convenience. If it is missing, you can write to us at the address on the inside of the front cover, or call or fax our offices at the numbers listed. We will be happy to hear from you.

**Registration Card**

Model # \_\_\_\_\_ Serial # \_\_\_\_\_ Purchase Date \_\_\_\_\_

Your name \_\_\_\_\_ Title \_\_\_\_\_

Company \_\_\_\_\_ Telephone \_\_\_\_\_

Street \_\_\_\_\_

City, State, Mail Code (Zip), Country \_\_\_\_\_

Purchased from \_\_\_\_\_ Price \_\_\_\_\_

Nature of your product application \_\_\_\_\_

Please rate the following from 1 to 10 (where 10 is the best possible rating, and 1 is the lowest):

Performance \_\_\_\_\_ Ease of use \_\_\_\_\_ Documentation \_\_\_\_\_ Cosmetics \_\_\_\_\_ Serviceability \_\_\_\_\_

Comments \_\_\_\_\_

\_\_\_\_\_

Please list the magazines you read most often, in order of priority \_\_\_\_\_

\_\_\_\_\_

95078-000-01 March 1990

scans von archive-org