

dbx Model 128

dynamic range enhancer
dbx II tape noise reduction system

INSTRUCTION MANUAL



HOW TO USE THIS MANUAL

To achieve maximum benefit from your 128, we recommend that you read the entire dbx 128 Operator's Manual and keep it handy for future reference. However, if you are familiar with expansion and compression, and with the use of dbx II tape noise reduction, the FUNCTIONAL CALLOUTS and BRIEF OPERATING INSTRUCTIONS should provide all the information you need to connect and operate the 128. These sections also serve as quick reference guides for occasional review.

The INTRODUCTION explains why and when to use dbx II tape noise reduction, expansion, compression, peak limiting and peak unlimiting. Combination applications are also covered. The remainder of the 128 Operator's Manual is a detailed set of connection diagrams, operating instructions and explanations of the 128's functions.

WARNING: TO PREVENT FIRE OR SHOCK HAZARD, DO NOT EXPOSE THIS APPLIANCE TO RAIN OR MOISTURE.

INDEX

| | |
|--|-----------|
| FUNCTIONAL CALLOUTS | 2 |
| BRIEF OPERATING INSTRUCTIONS | 4 |
| INTRODUCTION TO THE dbx 128 | 6 |
| WHEN TO USE COMBINATION APPLICATIONS | 9 |
| DETAILED OPERATING INSTRUCTIONS | 10 |
| CONNECTIONS | 11 |
| OPERATION | 14 |
| HINTS TO GET THE MOST OUT OF dbx TAPE NOISE REDUCTION | 20 |
| USING THE DYNAMIC RANGE ENHANCER SYSTEM | 21 |
| HOW TO SET UP COMBINATION APPLICATIONS | 24 |
| SYSTEM PERFORMANCE | 29 |
| TECHNICAL DETAILS OF dbx PROCESSING | 30 |
| COMPRESSOR/LIMITER AND EXPANDER, A SUMMARY | 33 |
| SIMPLE PRECAUTIONS WHEN USING ANY PROGRAM EXPANDER | 35 |
| SPECIFICATIONS | 36 |
| SCHEMATIC | 38 |
| dbx PRODUCT WARRANTY | 39 |
| FACTORY SERVICE | 39 |
| dbx GLOSSARY | I |

FUNCTIONAL CALLOUTS

Fig. 1 – Front Panel Callouts

BELOW, ABOVE THRESHOLD (L.E.D.'s)
When the amber indicator is illuminated, the input level to the 128 is below the threshold level adjusted by the LEVEL control. When the red indicator is illuminated, the input level to the 128 is above the threshold level. The L.E.D.'s do not measure output level.

DYNAMIC RANGE ENHANCER: PRE, POST (switches) When the 128 is in TAPE mode and the PRE switch is depressed, compression or expansion takes place ahead of the tape recorder's input (and before tape noise reduction encoding if the 128 is in REC mode); when the POST switch is depressed, compression or expansion takes place after the tape machine's output (and after tape noise reduction decoding if the 128 is in PLAY mode). When the 128 is in DISC mode press the POST switch.

PLAY LEVEL MATCH (control) Adjust this control if the playback level from a dbx II encoded tape is considerably different from the playback level of a non-encoded tape played back in the bypass mode. The setting is not critical.

PILOT (L.E.D. indicator light)
Shows that the AC power is ON (illuminated), or OFF (dark).

POWER (switch)
Controls the AC power to the dbx 128. Push once for ON, again for OFF.

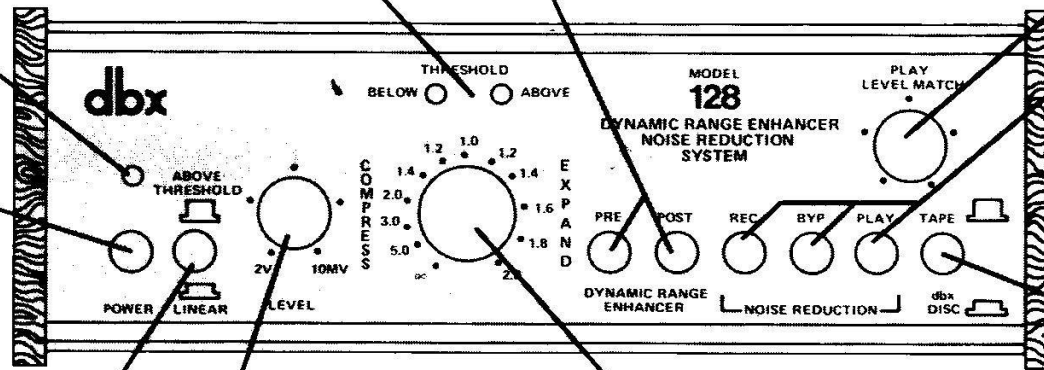

TAPE NOISE REDUCTION: REC, BYP, PLAY (switches) When the REC switch is depressed, the 128's tape noise reduction circuitry is ready for recording and encoding a tape with dbx II tape noise reduction. When the PLAY switch is depressed, the 128's tape noise reduction circuitry is ready for playback and decoding of an encoded tape. When the BYP switch is depressed, the 128's noise reduction circuitry is bypassed for recording or playback of non-encoded tapes.

TAPE/dbx DISC (switch) Set this switch to the DISC position, and press the PLAY switch for playback of dbx II encoded discs. The TAPE/dbx DISC switch should be in the TAPE position for recording or playback of dbx II encoded tapes.

ABOVE THRESHOLD/LINEAR (switch) In the LINEAR position (switch in), the compression/expansion section of the 128 operates in a normal fashion over the entire program dynamic range (see Figure 14 A & C). In the ABOVE THRESHOLD position (switch out), the compression/expansion section acts only on program levels that exceed the threshold set by the LEVEL control (see Figure 14 B & D). This changes the 128 into a peak limiter (corresponding to COMPRESS settings of the COMPRESS/EXPAND control) or a peak unlimiter (corresponding to EXPAND settings of the COMPRESS/EXPAND control).

LEVEL (control) Sets the "threshold" level above which compression or expansion begins when the ABOVE THRESHOLD/LINEAR switch is in the ABOVE THRESHOLD position. When the ABOVE THRESHOLD/LINEAR switch is in the LINEAR position, set the LEVEL control so that ABOVE THRESHOLD illuminates during loud passages, and BELOW THRESHOLD illuminates during quiet passages.

COMPRESS/EXPAND (control) Counterclockwise rotation of this control past the 1.0 setting turns the 128 into a compressor with a "compression ratio" given by the numbers on the surrounding scale.* Clockwise rotation of the control past the 1.0 setting turns the 128 into an expander with an "expansion ratio" given by the scale numbers.* When the COMPRESS/EXPAND control is set at the "1.0" setting (12 o'clock), the 128 does not compress or expand, and signals pass unchanged.

**The term "ratio," whether associated with "expansion" or "compression," refers to the amount of change in output level versus the input level. A compression ratio of 2:1 (a COMPRESSION setting of 2.0) means that for a 2dB change in input level there is a 1dB change in the output level. An expansion ratio of 1:2 (an EXPANSION setting of 2.0) means that for a 1dB change in input level there is a 2dB change in the output level. A ratio of 1:1 (a setting of 1.0) suggests neither compression nor expansion, so that for any change in input level there is a corresponding change in the output level.*

Fig. 2 — Rear Panel Callouts

RECORD LEVEL This screw-driver control is factory adjusted to match the record levels encountered in most home stereo equipment. Adjustment is not critical for encode/decode performance; if you have too much or too little level at the input to your tape recorder, see page 14 for adjustment instructions.

PLAY INPUTS Connect the cables from your tape recorder "playback" (or "monitor") outputs to these inputs.

QUAD COUPLER For compressing or expanding four channel programs, connect the QUAD COUPLER jacks of two dbx 128's together. This allows the compression/expansion circuits in both 128's to "track" each other so that the "quad image" remains stable.

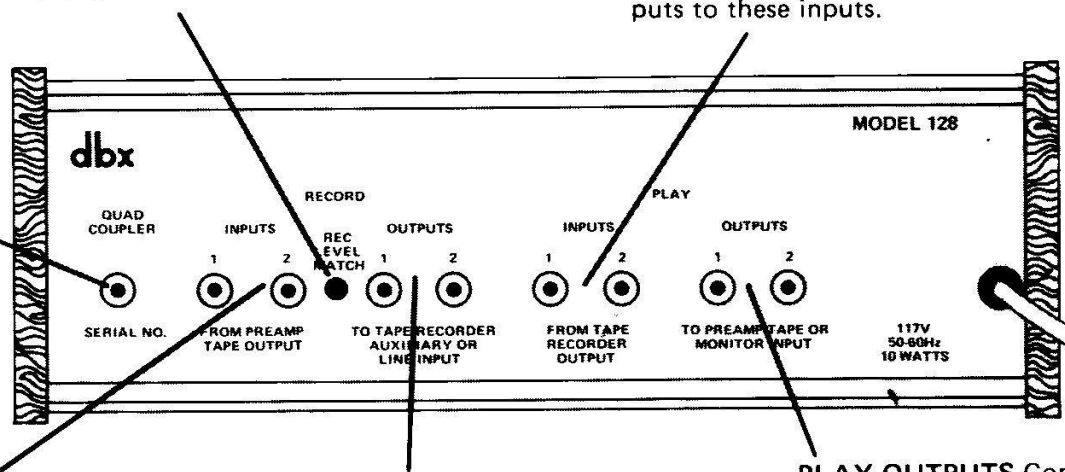

RECORD INPUTS For connection of the cables from your preamp's record output or tape output. If there is no tape output, use the main preamp output. Before installing the dbx 128, these cables were plugged directly into the "record" inputs of your tape machine. Microphones cannot be connected directly to the 128; a preamplifier or mixer must be used to provide line-level signals to the 128.

RECORD OUTPUTS Connect the cables from these outputs into the "record" inputs of your tape machine (line level or auxiliary inputs, not the mic inputs).

PLAY OUTPUTS Connect the cables from these outputs to the tape ("playback") input, preamp input, or tape monitor inputs of your preamplifier, amplifier or receiver. Before installing the dbx 128, these cables came directly from the tape recorder "playback" (or "monitor") outputs. (Figure 3, Page 7 illustrates these connections.)

NOTE: Never connect any other electronic equipment between the 128 and the tape recorder. See page 9 for connection of a graphic equalizer, reverb unit, etc.

BRIEF OPERATING INSTRUCTIONS

4

To Play a dbx-Encoded Phonograph Disc

1. Set your preamplifier's INPUT SELECTOR Switch to PHONO, and the TAPE MONITOR Switch to TAPE.

2. Press the 128's DISC, PLAY and POST Switches, and set the COMPRESS/EXPAND Control to the "1.0" position.

3. Play the disc and adjust the preamplifier's VOLUME Control for the desired listening volume. If the volume is considerably louder or quieter than normal, adjust the 128's PLAY LEVEL MATCH Control.

To Make a dbx-Encoded Tape

1. Set your preamplifier's INPUT SELECTOR Switch to the appropriate source (i.e. PHONO, TUNER or AUX), and the TAPE MONITOR Switch to TAPE.

2. Press the 128's TAPE, REC and POST Switches, and set the COMPRESS/EXPAND Control to the "1.0" position. Do not switch the 128 while recording.

3. With your tape machine in the Record Ready (Pause) mode, set recording levels for peaks typically 3 to 6 VU lower than the levels normally used. (With dbx processing, significantly lower recording levels are often required to avoid tape saturation, particularly in cassette recording.

Experiment during the initial setup to find the appropriate levels.)

To Play a dbx-Encoded Tape

1. Set your preamplifier's TAPE MONITOR Switch to TAPE.

2. Press the 128's TAPE, PLAY and PRE Switches, and set the COMPRESS/EXPAND Control to the "1.0" position.

3. Play the tape. If the volume is considerably louder or quieter than normal, adjust the 128's PLAY LEVEL MATCH Control.

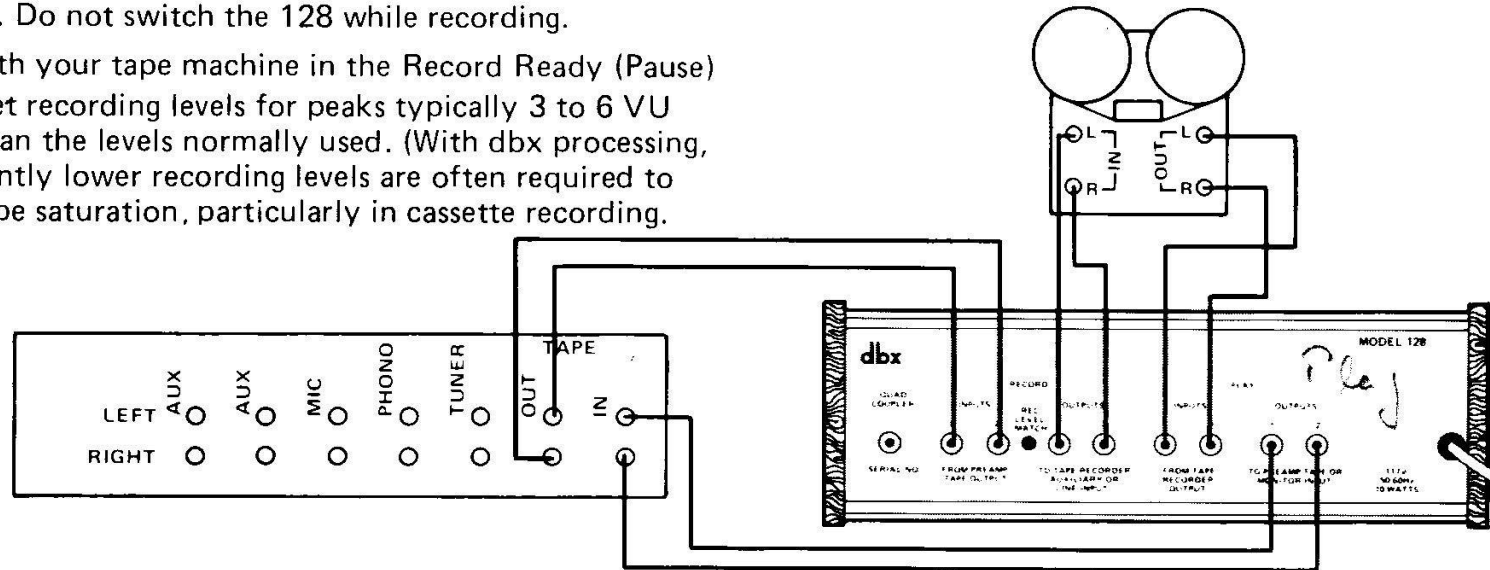

Fig. 3 – Basic Hook-Up Diagram

To Expand a Program

1. Set your preamplifier's INPUT SELECTOR Switch to the appropriate source (i.e. PHONO, TUNER or AUX), and the TAPE MONITOR Switch to TAPE.
2. Press the 128's DISC, BYP and POST Switches, and set the ABOVE THRESHOLD/LINEAR Switch to the LINEAR position (IN).
3. Set the COMPRESS/EXPAND Control to the desired degree of expansion (usually between 1.2 and 1.4). Do not over-expand, especially on classical music.
4. Set the LEVEL Control so that the ABOVE THRESHOLD LED lights on loud passages and the BELOW THRESHOLD LED lights on quiet passages.

To Peak Unlimit a Program

1. Set your preamplifier's INPUT SELECTOR Switch to the appropriate source (i.e. PHONO, TUNER or AUX), and the TAPE MONITOR Switch to TAPE.
2. Press the 128's DISC, BYP and POST Switches, and set the ABOVE THRESHOLD/LINEAR Switch to the ABOVE THRESHOLD position (OUT).
3. Set the COMPRESS/EXPAND Control to the desired degree of peak expansion (usually between 1.2 and 1.6).
4. Set the LEVEL Control so that the ABOVE THRESHOLD LED lights only on musical peaks, or for the desired effect.

To Compress a Program

1. Set your preamplifier's INPUT SELECTOR Switch to the appropriate source (i.e. PHONO, TUNER or AUX), and the TAPE MONITOR Switch to TAPE.
2. Press the 128's DISC, BYP and POST Switches, and set the ABOVE THRESHOLD/LINEAR Switch to the

LINEAR position (IN).

3. Set the COMPRESS/EXPAND Control to the desired degree of compression (usually between 1.2 and 3.0). Too much compression can cause unwanted side effects.

4. Set the LEVEL Control so that the ABOVE THRESHOLD LED lights on loud passages and the BELOW THRESHOLD LED lights on quiet passages.

To Peak Limit a Program

1. Set your preamplifier's INPUT SELECTOR Switch to the appropriate source (i.e. PHONO, TUNER or AUX), and the TAPE MONITOR Switch to TAPE.
2. Press the 128's DISC, BYP and POST Switches, and set the ABOVE THRESHOLD/LINEAR Switch to the ABOVE THRESHOLD position (OUT).
3. Set the COMPRESS/EXPAND Control to the desired degree of peak limiting (usually 10.0 or higher).
4. Set the LEVEL Control so that the ABOVE THRESHOLD LED lights only on musical peaks, or for the desired effect.

To Record with Peak Limiting and dbx II Tape Noise Reduction

1. Set your preamplifier's INPUT SELECTOR Switch to the appropriate source (i.e., PHONO, TUNER or AUX), and the TAPE MONITOR Switch to TAPE.
2. Press the 128's DISC (IN) BYP and POST Switches, and set the ABOVE THRESHOLD/LINEAR Switch to the ABOVE THRESHOLD position (OUT).
3. Set the COMPRESS/EXPAND Control for the desired degree of compression.

6

4. Set the LEVEL Control so that the ABOVE THRESHOLD LED lights only on musical peaks, or for the desired effect.

5. Now press the 128's TAPE (OUT) REC and PRE Switches.

6. With your tape machine in Record Ready (Pause) mode, set its input level controls.

7. Record the tape.

8. To play back the tape just recorded, press the 128's TAPE (OUT), PLAY and PRE Switches, and set the COMPRESS/EXPAND Control to the 1.0 position. Play the tape.

To Play a dbx-Encoded Tape or Disc and Add Peak Limiting

1. Press the 128's PLAY and POST Switches, and either the DISC or TAPE Switch depending on the source.

2. Set the ABOVE THRESHOLD/LINEAR Switch to the ABOVE THRESHOLD position (OUT).

3. Set the COMPRESS/EXPAND Control for the desired degree of peak limiting (usually 10.0 or higher).

4. Set the LEVEL Control so that the ABOVE THRESHOLD LED lights only on musical peaks, or for the desired effect.

5. Play the tape or disc.

A live musical performance is an exciting experience, the kind of experience that record manufacturers and radio stations *attempt* to capture for reproduction in home listening.

Unfortunately much of the excitement of the original live performance is lost, even when using the best speakers, amplifiers, tuners, turntables, and tape machines. The primary reason for this lack of excitement and realism is the dynamic range limitations in the recording and broadcast mediums.

Dynamic Range and Why It Is Important

Dynamic range can be defined as the difference in sound level, measured in dB, between the loudest and the quietest passages in music. Acoustical loudness is measured in decibels of sound pressure level, or dB SPL. The dB expresses the smallest change in sound level that the average ear can detect. 0 dB SPL is the threshold of human hearing, the faintest sound most people can hear at a midrange frequency (1,000 Hz). The loudest sound the average person can tolerate without physical pain is approximately 120 dB SPL (some people can tolerate 130 dB, others leave the room when the sound level reaches 110 dB). Thus, human hearing has a maximum dynamic range of about 120 dB SPL.

Noise is the lower restriction of the dynamic range of most recorded material. Typical sources of noise are phonograph disc surfaces, turntable rumble, tape hiss, and FM broadcast hiss. When the original program's quietest sounds are too low in level, they are buried in the noise. "Rumble" and "scratch" filters can remove some of this noise, but unfortunately, they also remove parts of the program. A simple but effective way to remove or reduce noise significantly without subtracting anything from the music has long been sought. One method to avoid noise-imposed restrictions in the recording and broadcast mediums would

be to raise the overall program level, allowing the louder sounds to become even louder. However, when the program's loudest sounds are too high in level, they cause distortion. Thus, the difference between the noise level and the maximum undistorted level of a tape machine, disc, or radio broadcast is not wide enough to accommodate the full dynamic range of a live performance.

To get around the inherent dynamic range limitations in a given medium, the original program is often "compressed." This means that its dynamic range is restricted by making the loud passages quieter and/or the quiet passages louder. Compression thus avoids the dynamic range limitations of the medium by reducing the dynamics of the program. Compression is effective, but unfortunately it also removes the program's excitement and realism. Given the necessity for compression, engineers long ago realized that if there were some way to reverse the process, restoring the dynamic range of the compressed program, the quality of recorded music could be significantly improved. Until recently, this "reverse compression" process, known as "expansion," had not been successfully applied in any consumer product.

dbx has developed techniques that make a dramatic improvement in the dynamic range of any recorded musical material: (a) the patented dbx II Tape Noise Reduction System for tape machines and phonograph discs, and (b) the linear decibel compression/expansion system. The dbx 128 incorporates both of these systems which may be used independently or in combination with each other. You can use the 128's dynamic range enhancer to reduce the noise of records or FM broadcasts, or you can capture all of the widest range program material on your conventional cassette or reel-to-reel tape recorder using dbx II tape noise reduction.

dbx II Tape Noise Reduction

dbx II tape noise reduction circuits "encode" a program before it is recorded on a tape recorder and "decode" it upon playback. This process reduces tape noise to inaudibility and retains the original program's dynamic range. This means that a recorded program will not have any more audible noise than the original source. Also, the dbx-encoded program will retain the dynamics and excitement of the original source without causing tape saturation.

When to Use the dbx II Tape Noise Reduction System

Use the 128's dbx tape noise reduction circuitry to avoid audible tape noise and increase headroom when you record a tape of a live performance, dub (copy) a conventional disc onto a tape, or record any other source, such as an FM broadcast.

The 128's tape noise reduction circuits can also be used to decode a dbx-encoded phonograph disc. dbx encoded discs have been recorded with dbx II noise reduction processing, and already have all the advantages of dbx noise reduction.

dbx tape noise reduction processing cannot reduce noise on an existing tape if it has been recorded without dbx encoding. Similarly, the dbx tape noise reduction circuits cannot reduce noise on conventional phonograph records. However, the dbx 128's expander circuits *can* reduce these types of noise, as explained in the next paragraph.

dbx Expansion and Compression

For the most part, noise in an FM broadcast or on a phonograph disc is only audible when the program levels are quiet. dbx linear decibel expansion increases the program dynamics so the loud levels become louder and the quiet levels, *including the noise*, become quieter. Simultaneously, expansion restores much of the dynamic

range and, therefore, the excitement of the original performance. The same circuits that do the expanding can be used to compress a program for background music or for making car stereo tapes, making the loud levels quieter, and the quiet levels louder. Depending on front-panel control settings, the linear decibel compression/expansion circuitry can also "peak limit" or "peak unlimit." Peak limiting is simply compression with the 128 set for "above threshold" operation. This prevents program levels from rising above an adjustable level (threshold), but has no effect on levels below that point. Conversely, peak unlimiting is simply expansion with the 128 set for "above threshold" operation. This increases the amplitude during the loud passages of the music, without affecting the program below the set threshold level.

When to Use Expansion

Use the 128's expansion capabilities to reduce the noise present in the original source. For example, you can expand a highly compressed and older recording and increase its dynamic range to the point where it is comparable to your best conventional phonograph discs and, at FM broadcast time, significantly reduce the hiss. Or you can expand a conventional disc and dramatically reduce surface noise and turntable rumble at the same time you increase its dynamics to recreate sound like a live performance.

When to Use Compression

Compression is used for recording a program which must have a relatively constant level, as for example when playing or recording background music. At the low listening levels of background music, quieter passages must be kept loud enough to be heard, yet loud passages must not

be too loud. Similarly, if you are recording music for playback in your automobile or any other high noise area, compression can keep the quiet sounds above the noise, while it holds the loud sounds below distortion-causing levels. Compression is also useful for a live recording of several people with different voice levels. In this case, the compressor acts like an automatic volume control and saves you the task of "gain riding."

When to Use Peak Limiting

If a tape must be recorded without the benefit of dbx II tape noise reduction (for later playback without dbx decoding), then peak limiting is very useful because it can prevent musical peaks from causing tape saturation. Peak limiting can also be used to protect speaker systems from extremely loud musical peaks, or from loud ticks or pops on a damaged phonograph disc.

When to Use Peak Unlimiting

Many record manufacturers, and all radio stations use some form of peak limiting in order to record or broadcast high average program levels without having sudden musical peaks saturate the tape or overmodulate the radio transmitter.

"Unlimiting" (peak expanding) with the 128 can correct the dynamic alteration created by peak limiting operations. For example, suppose you have a particularly good recording of a concert, one with excellent overall dynamics, however, some passages may lack the expected dynamic impact, giving an unnaturally controlled feeling where instruments should stand out. Such a recording probably had very little original compression, but had peak limiting applied to high level passages. The 128's peak *unlimiting* action could make this recording sound better.

WHEN TO USE COMBINATION APPLICATIONS

You can simultaneously use the 128's tape noise reduction circuitry plus any one of the following: expansion, peak unlimiting, compression or peak limiting.

When to Use dbx II Tape Noise Reduction Plus Expansion

By recording and playing back a program with dbx II tape noise reduction and then expanding it, you can end up with a program that actually has lower noise and better dynamic range than the original. This is especially effective on noisy phonograph discs.

When expanding or peak unlimiting a program that has been recorded with dbx II, the 128's expansion circuitry should come after the dbx II tape noise reduction circuitry (push the POST button). This allows the dbx tape noise reduction circuits to properly decode the program, before the expansion.

It is not necessary to use the 128's expansion circuitry when playing a dbx-encoded disc, since the encoded disc already has an extremely wide dynamic range. To avoid over expansion, always press the PRE button and set the COMPRESS/EXPAND control to the "1.0" (12 o'clock) position when playing a dbx-encoded disc.

When to Use dbx II Tape Noise Reduction Plus Compression

Normally, when making a recording with dbx Tape Noise Reduction, additional compression is not necessary. Compression might normally be used to restrict dynamic range, and to "get the program on the tape," but dbx encoding alone overcomes the dynamic range limitations of recording tapes. If you use compression plus dbx tape noise reduction, the compression would primarily be for special effects purposes.

When playing a tape which has been recorded with

dbx II tape noise reduction, or when playing a dbx-encoded disc, you can use the 128 for peak limiting (above threshold compression).

When adding compression or limiting while playing back a dbx-encoded tape or a dbx-encoded disc, the 128's compression circuitry should come *after* the 128's tape noise reduction circuitry (press the POST switch).

DETAILED OPERATING INSTRUCTIONS

10

GENERAL NOTES

Mounting

The 128 is supplied in a handsome cabinet that can be placed almost anywhere. Avoid mounting the 128 above any source of heat or strong electro-magnetic fields, such as those generated by power amplifiers or vacuum tube equipment.

Level and Impedance

The input levels, output levels and impedances of the 128 are designed for most hi-fi and semi-pro equipment. The 128's input impedance (for both the noise reduction and compression/expansion sections) is 50k-ohms, which means it can be driven from high or low impedance sources. The 128 input will accept a wide range of voltages. The output will drive up to 7 volts into 5000-ohms or greater. This means that you can confidently connect the 128 to almost any type of equipment found in a normal hi-fi or semi-pro system. See the specifications section on Page 39 for greater detail.

Grounding

The 128 is not grounded to the power mains through its power cord. It obtains a ground via the shields of the inter-connecting audio cables from the preamplifier (or receiver) and/or from the tape machine. No special ground wires need be connected between the 128 chassis and any other equipment. If you hear hum, try reversing the AC plug, and if that does not help, check to make sure all audio cables are properly installed, and that there are no broken conductors in any cable. Also try cleaning the connectors on your cables since hum and radio station pickup are sometimes caused by microscopic dirt particles between the mating surfaces of the connectors.

Cable Length

Some installations will tolerate longer cables, but whenever possible it is a good idea to keep signal cable runs under 10 feet. This will minimize hum and noise pickup, and also help prevent high frequency losses naturally caused by cable capacitance.

dbx and Dolby®* Together

The dbx II tape noise reduction system provides at least 20 dB more reduction of noise than Dolby "B" tape noise reduction systems, and 15 dB more than Dolby "A", so there is no need to use Dolby processing. If your tape machine has internal Dolby processing, leave it off, and use only the dbx II encoding and decoding. Dolby processed tapes are not compatible with dbx II decoding (and vice-versa); if a tape was recorded with Dolby encoding, it must be Dolby decoded. A Dolby decoded tape may then be expanded.

NOTE: It is possible to combine both dbx II and Dolby processing, though we do not recommend it. Any imperfections in the Dolby encode/decode processing will be magnified by dbx II treatment. Since dbx II processing alone reduces noise to inaudibility, there is really no need to use dbx II with another system.

*"Dolby" is a trademark of Dolby® Laboratories Inc.

Where to Connect Your dbx 128

If your preamp, receiver, or integrated amp/preamp has tape monitoring provisions, the 128 should be connected within the tape monitor loop. In other words, connect the TAPE OUT of your preamp to the 128's RECORD INPUTS, and connect the 128's PLAY OUTPUTS to your preamp's PLAY or TAPE INPUTS (Figure 4).

For preamps, receivers or integrated amps that *do not have tape inputs and outputs*, connect the PREAMP OUTPUTS to the 128's RECORD INPUTS, and connect the 128's PLAY OUTPUTS to your main amp INPUTS (Figure 5). (NOTE: When making recordings with this setup, keep all filter and tone controls set at "flat," or whatever setting yields the flattest frequency response. Tonal adjustments can be made when playing back the tape.)

Where to Connect Your Tape Recorder

Connect the 128's RECORD OUTPUTS to the RECORD INPUTS, or LINE INPUTS of your tape recorder. Do not

connect the 128's RECORD OUTPUTS to the MIC INPUTS of your tape recorder; the output level from the 128 is too high for most mic inputs, and could cause distortion. Connect the PLAY OUTPUTS, MONITOR OUTPUTS, or LINE OUTPUTS of your tape recorder to the PLAY INPUTS of the 128 (Figure 4).

Caution: Make sure that the power is OFF on all equipment when installing the 128. As a precaution, turn down the volume on your amplifier prior to switching on the 128 for the first time. Inadvertent decoding of non-encoded programs (128 in PLAY mode) can create surging to high volume levels.

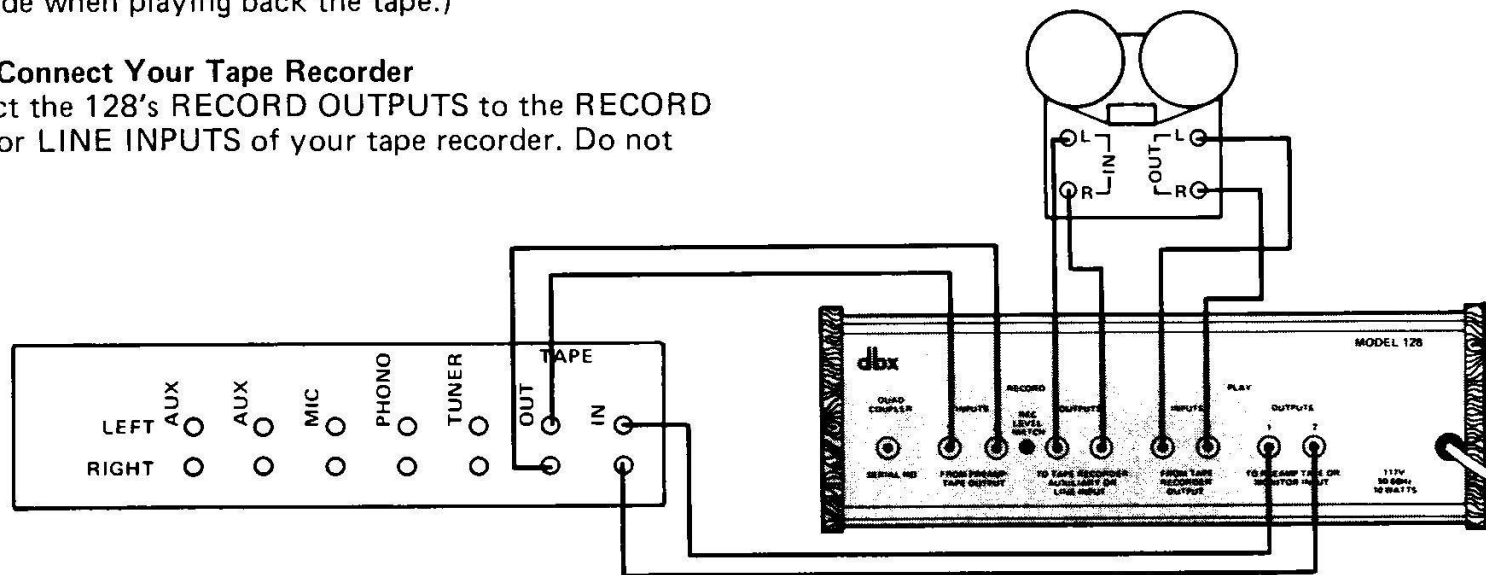

Fig. 4 – Connecting the 128 in a Tape Monitor Loop

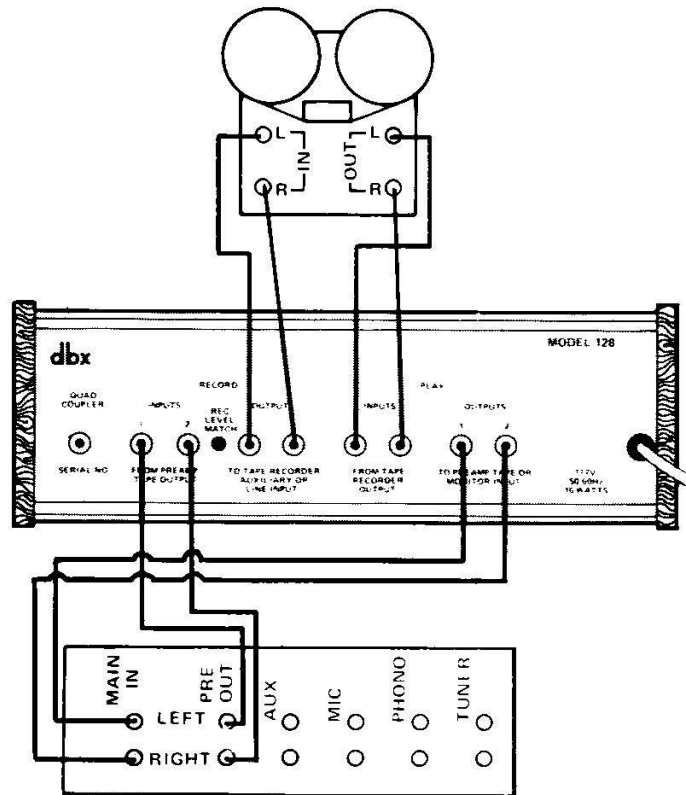

Fig. 5 – Connecting the 128 when there is No Tape Monitor Loop

NOTE: Using different preamp VOLUME CONTROL settings changes the THRESHOLD and LEVEL MATCH settings.

Graphic Equalizers

If you use a graphic equalizer with your hi-fi, the equalizer must not be connected between the 128's RECORD OUTPUTS, and the tape recorder's inputs, or between the recorder's outputs and the 128's PLAY INPUTS. Ideally the 128 can be installed in the tape monitor loop, and the graphic equalizer installed between the preamp output and the power amplifier input (Figure 6).

Equalized Speaker Systems

If you have an equalized speaker system, such as a Bose or Electro-Voice "Interface: A," then the 128 should be connected in the tape monitor loop of the speaker equalizer and the equalizer should be installed in the tape monitor loop of the preamp (Figure 7).

Note: Never connect any other electronic equipment between the 128 and your tape recorder inputs. This could cause inaccurate encode/decode tracking and loss of quality in the recorded signal.

Re: Fig. 6 & 7 – If you are using an equalizer with your amplifier, you can hook it up either as shown in Fig. 6 or Fig. 7. Either hookup works equally well.

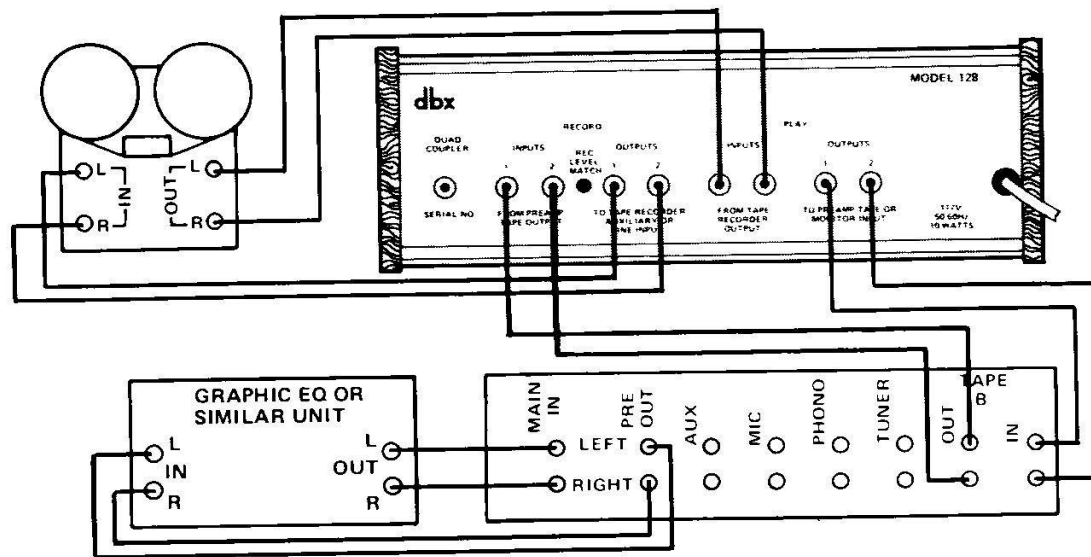

Fig. 6 – Where to Connect a Graphic Equalizer, Electronic Crossover, Reverb, Matrix 4-Channel Decoder, Etc. (Special signal processing follows the dbx encode/decode process.)

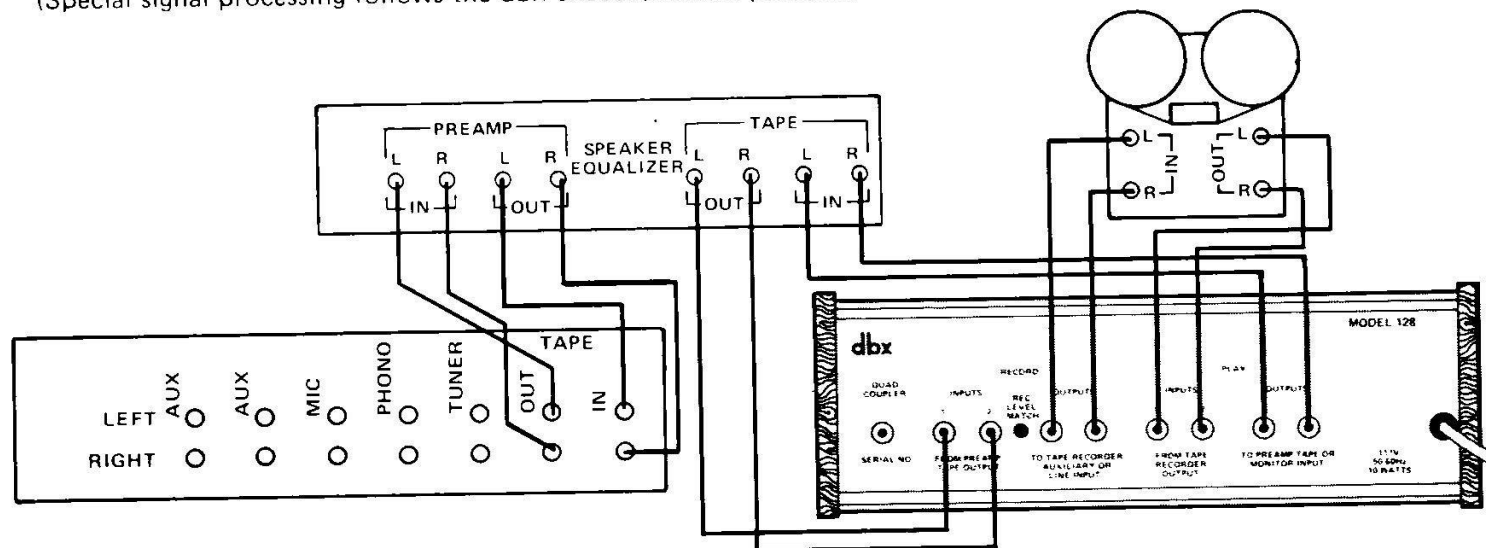

Fig. 7 – Connecting the 128 with an Equalized Speaker System. (The dbx processing is done inside the tape monitor loop of the speaker equalizer, which itself is in the tape monitor loop of amplifier.)

OPERATION— (If a rotary control setting is not indicated, the setting does not affect that operation.)

Aufnahme mit dbx-Codierung

Making a dbx-Encoded Tape

1. Set the 128's front panel switches and controls as shown.

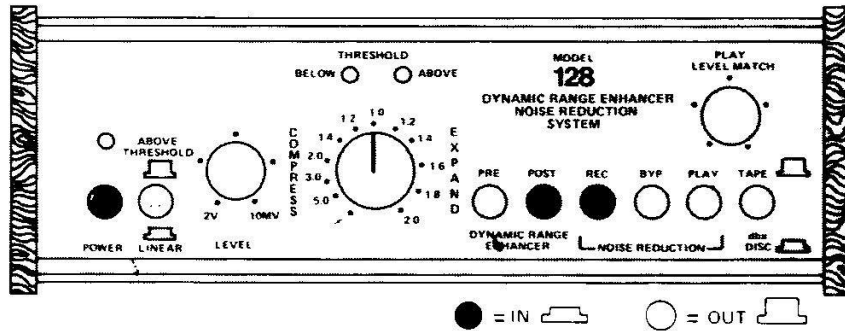

2. Using an input signal that is similar in level to the program to be recorded (or using the program itself), place the tape machine in RECORD READY (PAUSE) mode and set the machine's recording level for maximum VU meter readings of about 0VU (−3VU for cassette recorders).*

*Record Level Match Control

The REC LEVEL MATCH control on the rear of the 128 is factory adjusted to perform well with home hi-fi or semi-pro equipment. Exact level matching is not necessary for accurate encode/decode operation; the control is provided for use only when there is an extreme level mismatch between the output of the 128 and the input of your tape recorder.

If you have to turn the input level controls on your tape recorder to extreme high or low settings to make the VU meters read in their normal range, then adjust the REC LEVEL MATCH control as follows:

Place your machine in RECORD READY mode (PAUSE) with the input level controls at a normal position (about 12 o'clock on most machines).

These, or even lower recorded levels may be used with success because the dbx processing prevents audible tape noise.

3. Feed a normal level program (from a phonograph disc, FM broadcast, etc.) into the tape recorder through the 128, and adjust the REC LEVEL MATCH control until the tape recorder's VU meters display a proper maximum level. (about 0VU for reel to reel machines, about −3VU for cassette machines). Alternatively, for greater precision, use a test record with a 1kHz tone. (Frequencies between 400Hz and 1kHz are acceptable.)

Wiedergabe von dbx-codierten Aufnahmen
Playing Back a dbx-Encoded Tape

1. Set the 128's front panel switches and controls as shown.

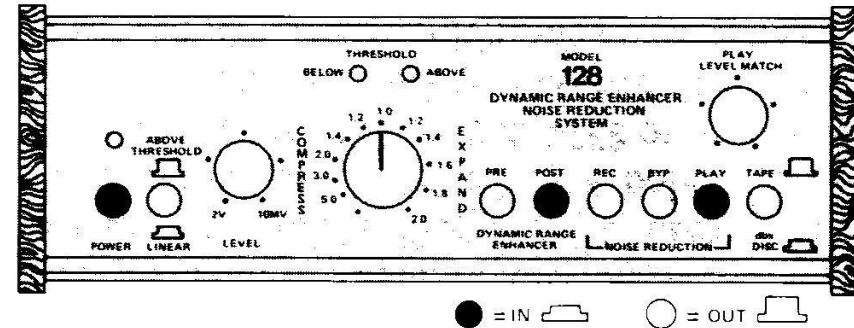

2. Place the tape machine in PLAY mode and play the tape.

3. If the playback volume is considerably louder or quieter than the original recorded volume, adjust the PLAY LEVEL MATCH on the 128.

Playing a dbx-Encoded Disc

1. Set the 128's front panel switches and controls as shown.

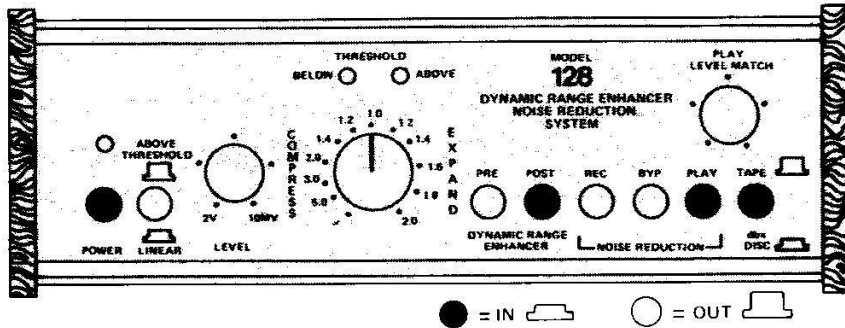

2. Set your receiver or preamplifier as follows: Selector Switch in the PHONO position, TAPE MONITOR Switch to TAPE.

3. Play the disc.

4. If the average playback level is much quieter or louder than that of a normal disc without the 128 decoding, adjust the 128's PLAY LEVEL MATCH control.

Dubbing (Copying) an Encoded Disc onto a Tape in Encoded Form

To dub a dbx-encoded disc onto a tape and retain the dbx-encoding:

1. Set the 128's front panel switches and controls as shown.

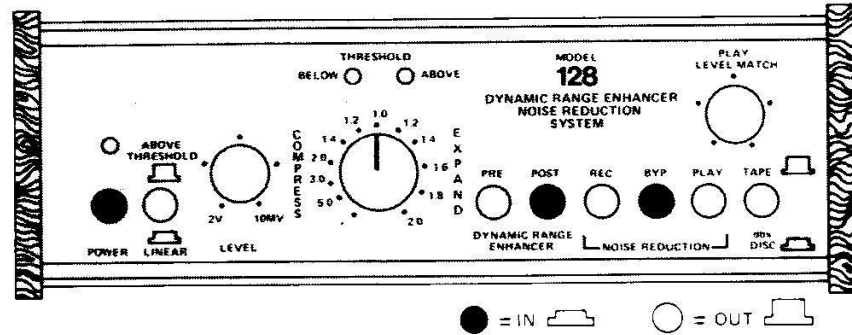

2. Set your receiver or preamplifier as follows: Selector Switch in the PHONO position, TAPE MONITOR Switch to TAPE.

3. Play the disc, and record normally. You are not decoding the disc, but are merely copying it in encoded form. The resulting tape can be played back in the same manner as any dbx II encoded tape.

Dubbing an Encoded Disc Onto a Tape in Non-Encoded Form

To record a dbx-encoded disc in non-encoded form onto a tape for future playback without dbx processing:

Normally the cables from the RECORD OUTPUTS on your preamplifier, amplifier or receiver are connected directly to the RECORD INPUTS on the 128.

1. Connect the PLAY OUTPUTS of the 128 directly to your tape recorder's RECORD INPUTS.
2. Set the 128's front panel switches and controls as shown.

3. Place your tape recorder in RECORD READY (PAUSE) mode and start the disc. Adjust the recorder's input controls to approximately the same setting used for normal recording. Then adjust the 128's PLAY LEVEL MATCH for maximum tape recorder OUV readings (about -3 for cassette recorders).

4. Play the disc and record normally. Note that this recording, because it is *not* dbx encoded, will have about as much noise and distortion as any conventional, non-dbx II encoded recording.

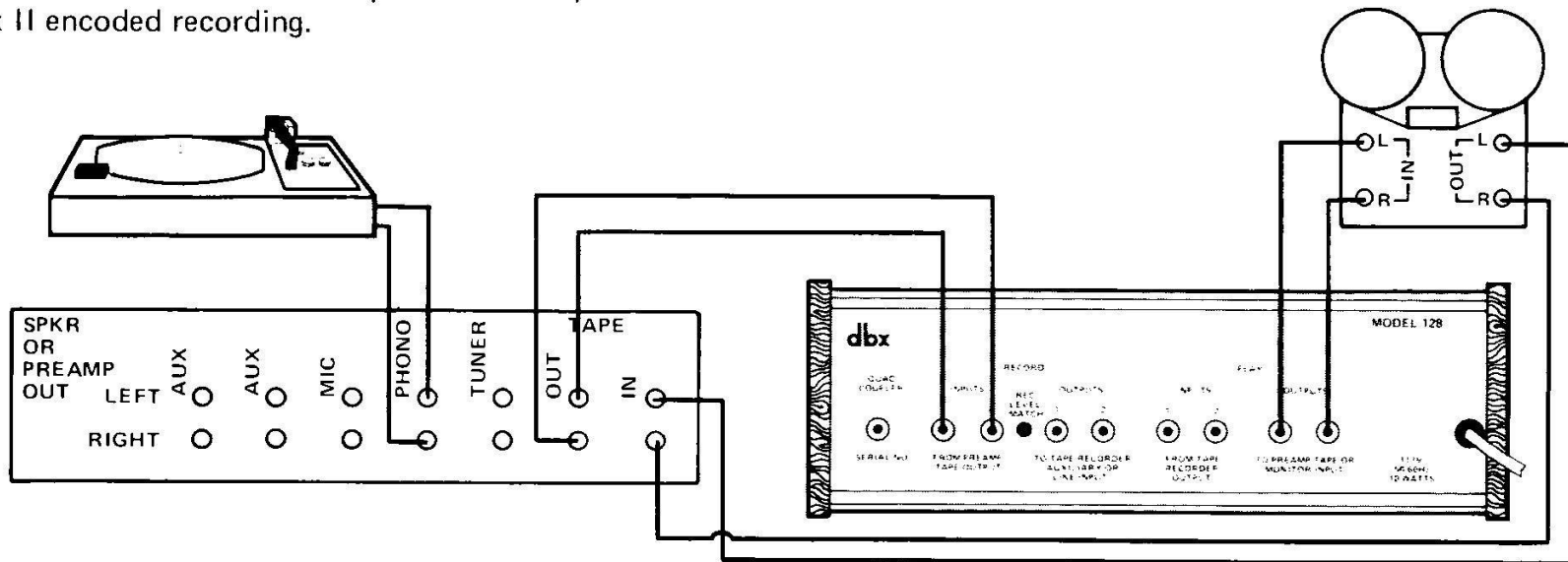
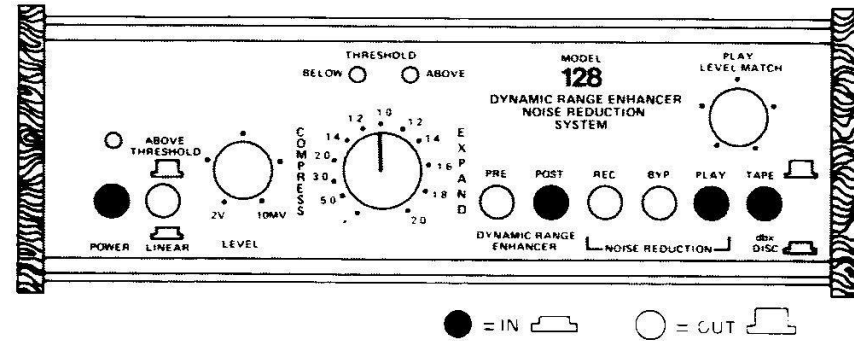

Fig. 8 – Special Connections for Dubbing an Encoded Disc onto a Tape in Non-Encoded Form

Tape Copying (Dubbing)

Making a dbx-encoded copy from a dbx-encoded master* provides a copy with no more audible noise than the master tape.

1. Since the encoded tape does not require additional dbx II processing in order to be copied, the master machine's PLAY OUT can be connected directly to the slave machine's RECORD INPUT. If the signal passes through the 128, it is not necessary to disconnect the unit, just press the BYP button. (Figure 9)

2. Adjust the record levels on the slave machine as if recording with dbx II processing.

3. Tape copies encoded on the 128 can be played through any dbx II decoder (120 series), and will have no more audible noise than the original master tape. See page 30 for a discussion of the encoded/decoded processing

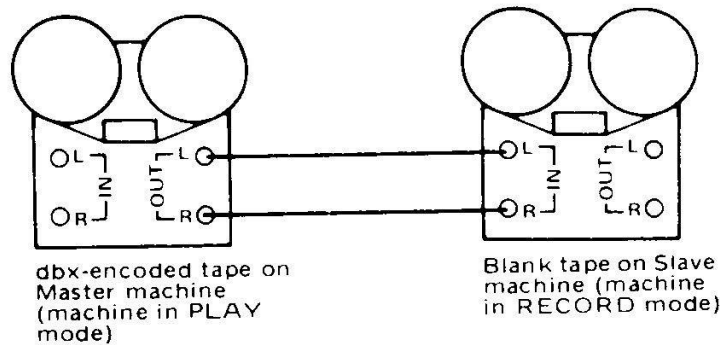

Fig. 9 – Copying dbx-Encoded and Unencoded Tapes Directly from One Tape Machine to the Other.

**In the discussion of copying, we use the term "master machine" to refer to the tape machine with the program to be copied. We use the term "slave machine" to refer to the tape machine which is to record the program.*

differences in dbx professional systems and dbx II systems.

(Making a non-dbx-encoded copy from a non-encoded master is identical to the procedure outlined above, although average recording levels should be raised to conventional levels.)

Aufnahme mit dbx von Normalband

Making a dbx-Encoded Copy from a Non-Encoded Tape

This is occasionally desirable. The copy will not have any more audible noise than the original.

1. If your preamp (or receiver) has two tape monitor loops with switching for "Dub A to B" or similar copying provisions, connect your system as shown in Figure 10.

2. Set the 128's front panel switches and controls as shown.

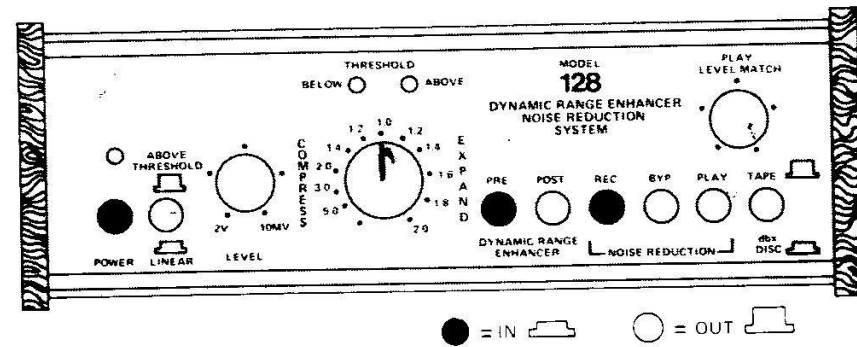

3. Set the preamp to dub from the Master (machine A) to the Slave (machine B) and copy the tape.

Aufnahme ohne dbx vom dbx-codiertem Band

Making a Non-Encoded Copy from a dbx-Encoded Master

This is sometimes necessary so that the copy can be played without the benefit of dbx II tape noise reduction. The copy will be similar to an original recording made without the benefit of dbx processing: in other words, with restricted dynamic range and audible tape hiss.

1. The encoded master tape must be dbx-decoded prior to feeding the slave machine. This may be accomplished in a number of ways depending on the nature of your installation.

2. If your preamplifier, amplifier or receiver has two tape monitor loops with switching for "Dub A to B" or similar copying provisions, connect your system as shown in Figure 10.

3. If your preamp (or receiver) has only one tape monitor loop, there are two ways to make a non-encoded copy.

Either disconnect the dbx PLAY OUTPUTS from the preamp's monitor inputs, and connect the cables instead to the slave machine's RECORD INPUTS, or simultaneously connect the dbx PLAY OUTPUTS to the preamp and to the slave's RECORD INPUTS by using a "Y" adapter as shown in Figures 11 & 12.

4. In either case, set the 128's front panel switches and controls as shown.

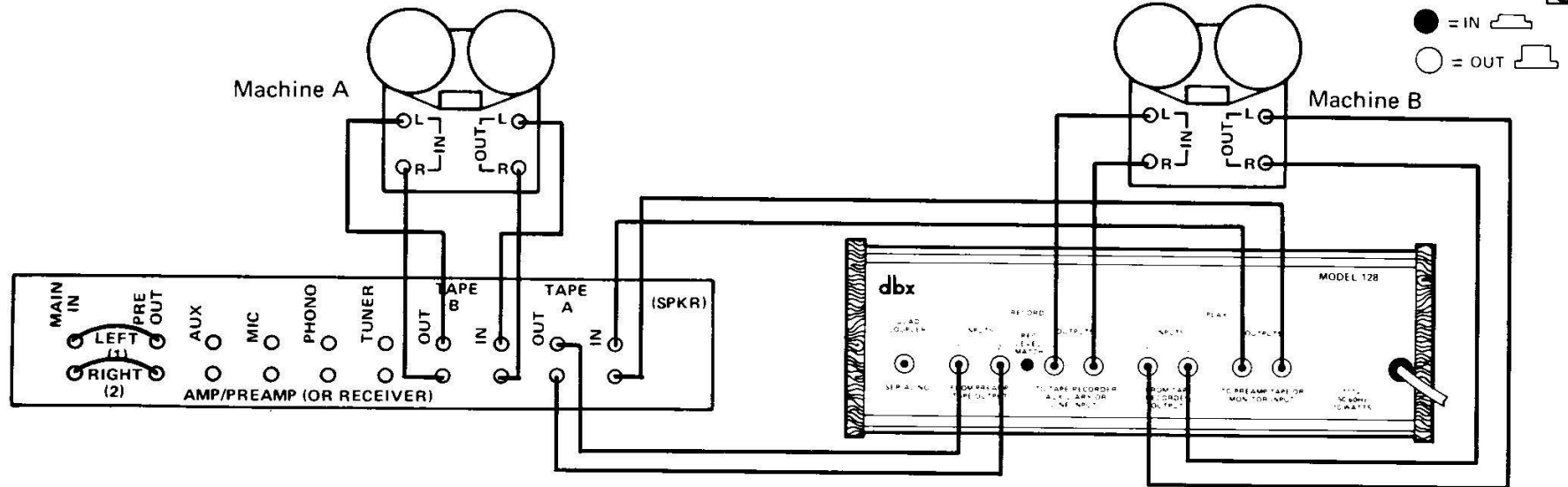

Fig. 10 – Copying dbx-Encoded and Non-Encoded Tapes with a Preamp having Two Tape Monitor Loops.

5. Place the slave machine in record mode and the master machine in play mode and copy the tape.

Fig. 11 – Making a Non-Encoded Copy from dbx-Encoded Master without a Preamp.

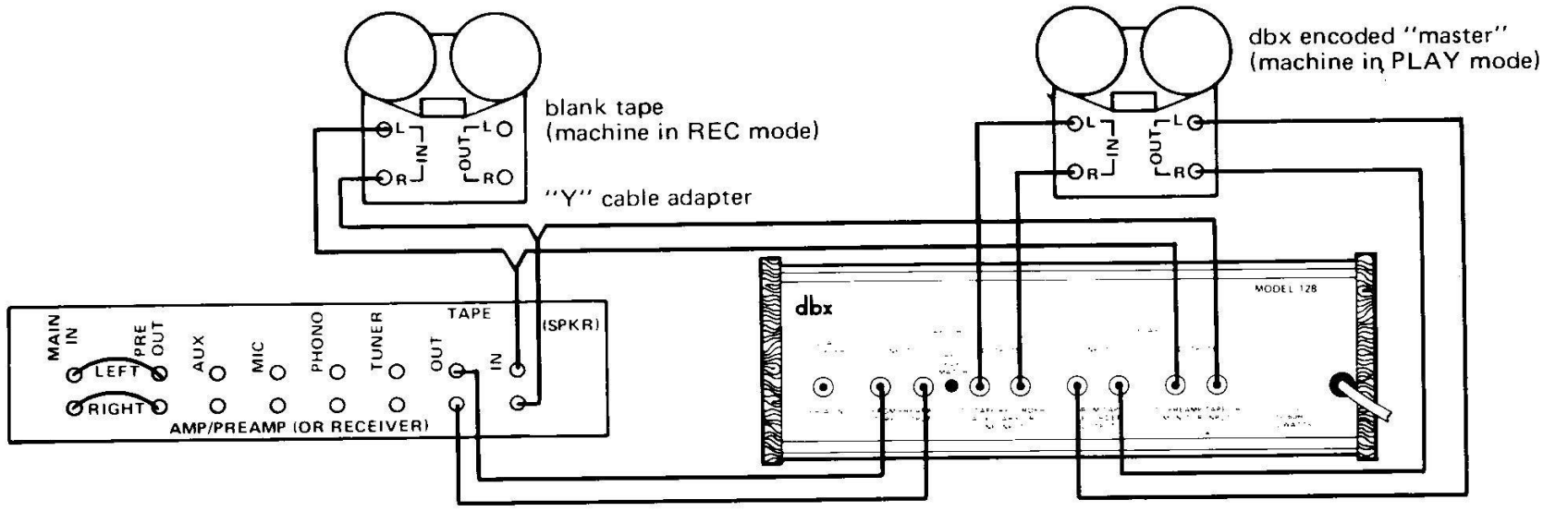
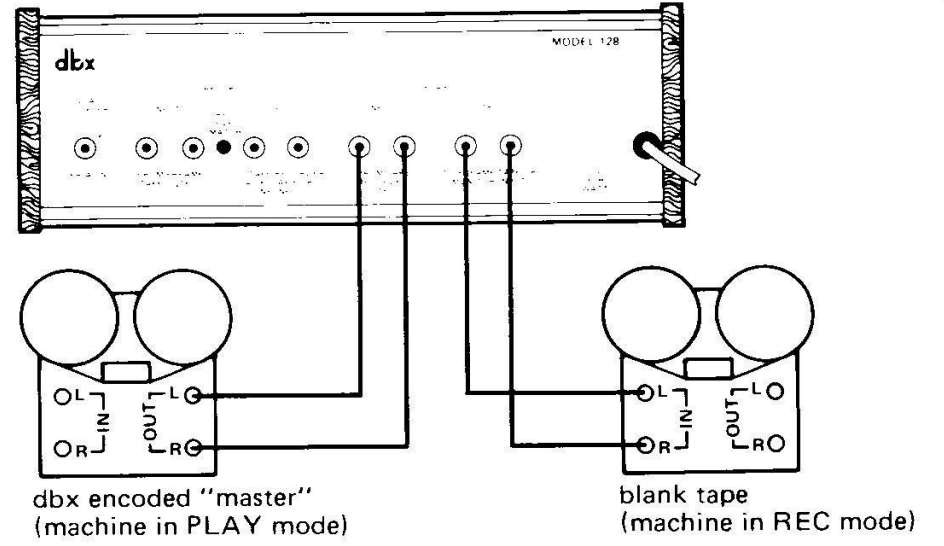

Fig. 12 – Making a Non-Encoded Copy from a dbx-Encoded Master without the benefit of Two Tape Monitor Loops.

HINTS TO GET THE MOST OUT OF dbx TAPE NOISE REDUCTION

20

Mixing

Individual channels which have been dbx-encoded cannot be mixed together unless they are first individually decoded. In fact, encoded tapes must be decoded before limiting, equalization, or any other special signal processing (except level or gain changes).

Recording Levels

Maximum recorded levels (as displayed on your tape machine's VU meters) will be somewhat lower with the 128 switched to REC mode, and minimum levels will be higher. In other words, the VU meter on the tape recorder will not "track" the VU meter (if any) on the preamp or mixer. This effect is due to the 2:1 compression. The average peak readings on the tape recorder meters should be significantly lower when recording with dbx encoding, especially with cassette machines. This level allows plenty of headroom for peaks without danger of tape saturation, and it simultaneously provides adequate separation from the tape noise.

Special Tapes

It is not necessary to increase record levels to "take advantage" of elevated level (High Output Low Noise) tapes. Instead, it is desirable to retain standard record and play levels, providing extra headroom for truly accurate transient response. The extra few dB of recorded level are not necessary because dbx processing avoids residual tape noise even with standard tapes. We recommend the new smooth surfaced tapes (calendered tapes) which have inherently low noise.

Bias, Equalization and Alignment

Hiss level in tape recording is a function of the recorded

signal level as well as bias level. In order to minimize tape modulation noise, it is important that the tape machine be properly biased for the particular tape used. If your tape machine has bias and equalization switches, experiment to find the settings that yield the lowest tape modulation noise and the best frequency response with dbx encoding and decoding. Proper head alignment is also important because the 2:1 expansion of the dbx decoding can exaggerate any frequency response errors in the tape record/playback process. In addition, always keep your tape heads clean and demagnetized to avoid extra noise and distortion.

Effects

When recording with dbx II tape noise reduction, use limiting and compression for special effects only. The dbx encoding process makes routine limiting and compression completely unnecessary. (As stated in the hint "Mixing", any such signal processing would be before encoding, if at all.)

Microphones and Pickups

When making live recordings from microphones or instrument pickups, the signal level must first be preamplified before being applied to the 128's RECORD INPUT jacks. If your tape machine has mic preamplifiers, these cannot be used because they would bypass the dbx encoding. A low noise preamplifier should be used to take full advantage of the noise reduced recordings. Some stereo receivers have mic preamps, and there are relatively inexpensive battery powered mic preamps, too.

Coughs, shoe scuffs, and similar sounds which may never have been audible in conventional recordings can become an annoyance when captured on a quiet dbx recording, so the ambient room noise should be held to an absolute minimum.

Subsonics and Interference

The dbx 128 incorporates very effective bandpass filters that maintain full frequency response throughout the audible spectrum (-3 dB at 27 Hz and 27 kHz). Their purpose is to reduce sub and supersonic (bias) frequencies to prevent them from introducing errors into the encode or decode process. However, in some extreme instances, rumbles from passing trains, trucks, aircraft, or even air conditioning may be picked up by your microphones and fed to the 128's compression circuitry.

These subsonics can cause the RMS level sense detector to modulate the program, even though the low frequencies themselves are not audible and are not passed onto the tape (a tape machine usually cannot record frequencies below 30 Hz). As a result, the low frequency information is missing upon playback, and the decoder is "fooled", causing a mysterious and unwanted deviation in program level.

Should you encounter this rare problem, it can be eliminated by using a high pass filter between the microphone preamplifier and the 128 record input; the "rumble" filter on your amplifier or receiver is suitable. If unexplained playback level deviations occur after copying a conventional phonograph disc onto a tape (using dbx II tape noise reduction encoding), use of the "rumble" filter during recording will solve the problem by cutting subsonic frequencies.

USING THE DYNAMIC RANGE ENHANCER SYSTEM

Alleinige Benutzung der Dynamik-erweiterung

21

How to Use the Expander Alone, Without dbx II Tape Noise Reduction* (Linear Expansion)

1. Set the 128's front panel switches and controls as shown.

ohne dbx-Rauschunterdrückung

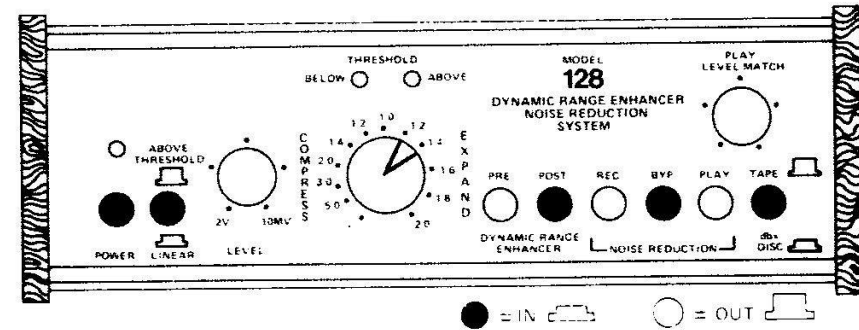

2. Set the EXPANSION/COMPRESSION control to the desired expansion ratio (on the right hand side of the control scale). An expansion ratio of 1.1 creates a 10% increase in dynamic range, 1.2 creates a 20% increase, 1.3 a 30% increase, and so forth . . . up to 2.0, which creates a 100% increase in dynamic range.

The amount of expansion is continuously adjustable from 1.0 (a 1:1 ratio for no effect) to 2.0 (a 1:2 ratio for maximum effect), for two reasons. First, different listeners desire varied degrees of expansion to suit their musical tastes. Second, various program sources have differing amounts of compression, and will therefore require different amounts of dbx expansion to achieve similar results. Most users prefer to set the EXPANSION/COMPRESSION control between 1.2 and 1.5 (1:1.2 to 1:1.5) depending on the recorded material. It is recommended that settings of 1.2-1.4 be used for classical music and 1.3-1.5 for popular music. Too much expansion often

*Combined expansion and noise reduction are covered in the next section.

results in the audible variation of background noise that is usually described as “breathing” or “pumping.” One way to adjust the control is to increase the amount of expansion until it sounds extreme, then back off a little.

3. Set the LEVEL control to a point where the BELOW THRESHOLD and ABOVE THRESHOLD indicators are amber during quiet passages and red during loud passages. The numbers around the LEVEL control refer to the actual input voltage (the “threshold”) at which the 128 decides whether to expand upward (increase the volume) or expand downward (decrease the volume and the noise). When the BELOW THRESHOLD LED is on, the 128 is decreasing the program level, and when the ABOVE THRESHOLD LED is on, the 128 is increasing the program level.

How to Playback Using dbx II Tape Noise Reduction Plus Expansion

1. Set the 128’s front panel switches and controls as shown.

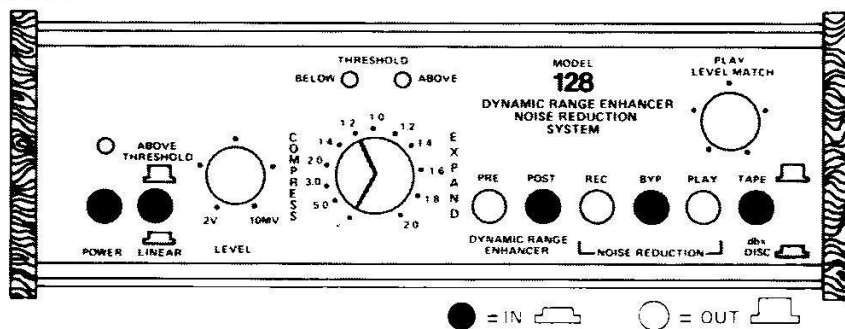

2. Set the COMPRESS/EXPAND control (the amount of expansion) while listening to the program through the 128’s expander section. Set the LEVEL control to a point where

the BELOW THRESHOLD and ABOVE THRESHOLD indicators are amber during quiet passages and red during loud passages.

2. Set the EXPANSION/COMPRESSION control to the desired compression ratio.

Note that the control is continuously adjustable from 1.0 (a 1:1 ratio for no effect) to infinity (an infinity to one ratio for extreme compression). As with the expansion side of the control, a good way to adjust the control would be to turn it farther toward the infinity: 1 setting until the effect seems extreme, then back off a little or adjust for the desired sound.

3. Set the LEVEL control to a point where the BELOW THRESHOLD indicator (amber) illuminates during quiet passages, and the ABOVE THRESHOLD indicator (red) illuminates during loud passages. The numbers around the LEVEL control refer to the actual input voltage, the threshold at which the 128 decides whether to compress downward (decrease the volume) or compress upward (increase the volume). Refer to the glossary for a definition of “threshold.”

If the control is set high (counterclockwise), the program volume may decrease somewhat; if the control is set low (clockwise), the program volume may increase somewhat. The amount of compression that takes place is not affected by the setting of the LEVEL control and adjustment is non-critical.

How to Use the Peak Unlimiter/Peak Limiter

1. Set the 128's front panel switches and controls as shown.

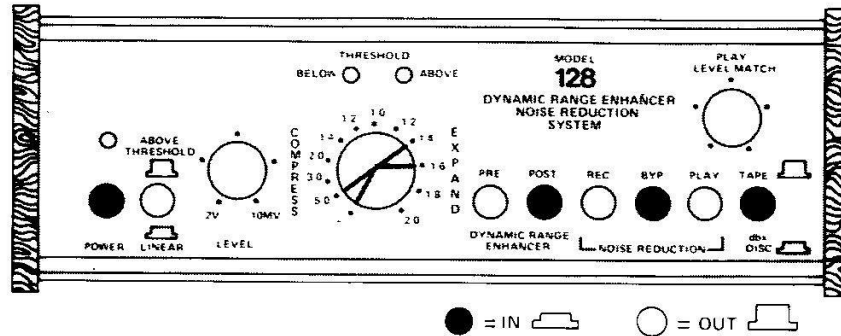

2. Adjust the COMPRESSION/EXPANSION control to the desired expansion or compression ratio. For peak unlimiting, set expansion between 1.4 and 1.6. For peak limiting, set compression at a relatively high ratio (10.0 or higher).

3. Adjust the LEVEL control so that the ABOVE THRESHOLD indicator (red) illuminates only on musical peaks. When peak limiting, compress only the highest peaks of the program and the effect will be less noticeable.

Quad Operation

With two 128's you can expand a quad recording or FM broadcast and gain the same benefits you would in stereo with a single 128. Connecting the two 128's together at their QUAD CONNECTORS allows the circuits of the two units to "track" each other so that the "quad image" will not shift unnaturally.

1. Set up the two 128's normally, using one for the front two channels, and the other for the rear two channels.

2. Connect the QUAD CONNECTORS of the two units together with a spare patch cable, as per in Figure 13.

3. Simultaneously feed the front stereo signals to the

front 128 and the rear stereo signals to the rear 128. The front panel mode switches and controls on both units should be adjusted to exactly the same positions. Then adjust the level match control only on the rear-channel 128 so that both units "track" one another. That is, set the level match control so that the red or amber L.E.D.'s on both 128's flash on in almost perfect synchronization, and so that the output levels from both 128's are nearly identical. Once the level match is set for proper tracking, do not readjust it.

To use the dbx II tape noise reduction sections of the two 128's for quad recordings, simply operate the two 128's as if you were doing two separate stereo recordings. It is not necessary to connect the two QUAD CONNECTORS together for quad tape noise reduction, but you can leave them connected together if you intend to expand the program before or after recording.

To expand a quad program before dbx II tape recording, follow the instructions to the right for stereo expansion and encoding. Adjust the two 128's separately.

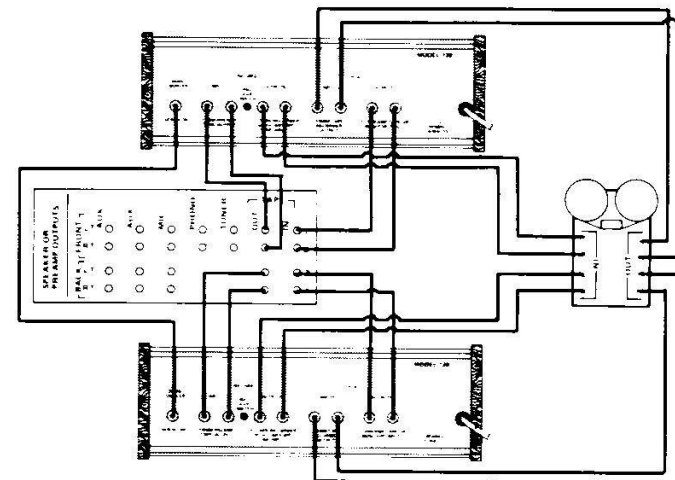

Fig. 13 – 4 Channel Operation with Two dbx 128's

HOW TO SET UP COMBINATION APPLICATIONS

24

Empfang mit dbx-Codierung und

Tape Noise Reduction plus any one of the following: expansion, peak expansion (unlimiting), compression or peak compression (limiting).

gleichzeitiger Dynamikübertragung

How to Record Using dbx II Tape Noise Reduction Plus Expansion

1. Set the 128's front panel switches and controls as shown.

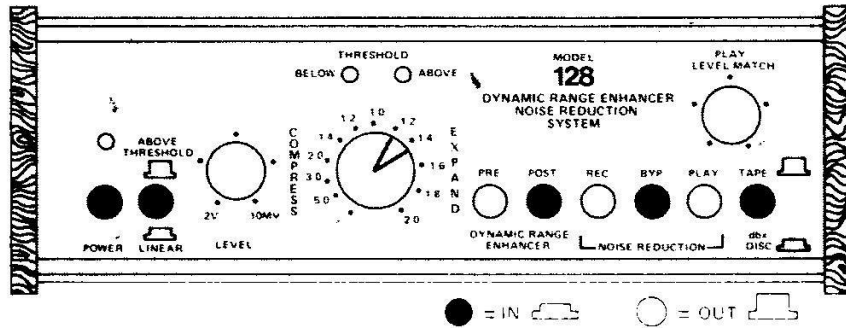

2. At this point, before recording, set the COMPRESS/EXPAND control (the amount of expansion) while listening to the program through the 128's expander section. Set the LEVEL control to a point where the BELOW THRESHOLD and ABOVE THRESHOLD indicators are amber during quiet passages and red during loud passages.

3. Set the 128's LEVEL control so the above THRESHOLD LED lights only on musical peaks, or for the desired effect.

Auspielen von dbx-codiertem Programm bei gleichzeitiger Dynamikübertragung

How to Peak Limit while Decoding a dbx II-Encoded Program

1. Set the 128's front panel switches and controls as shown.

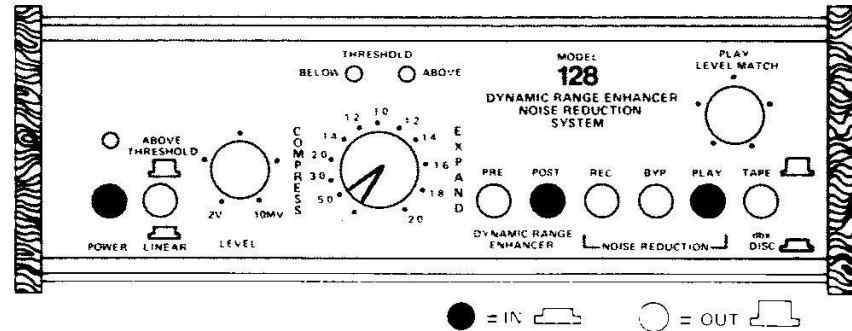

2. Set the TAPE/DISC for the program being played.

3. Set the COMPRESS/EXPAND control between 10 and infinity, and set the LEVEL control so that the ABOVE THRESHOLD (red) indicator illuminates only on musical peaks, or for desired effect.

4. Play the tape.

5. If the playback volume is considerably louder or quieter than the original recorded volume, adjust the 128's PLAY LEVEL MATCH.

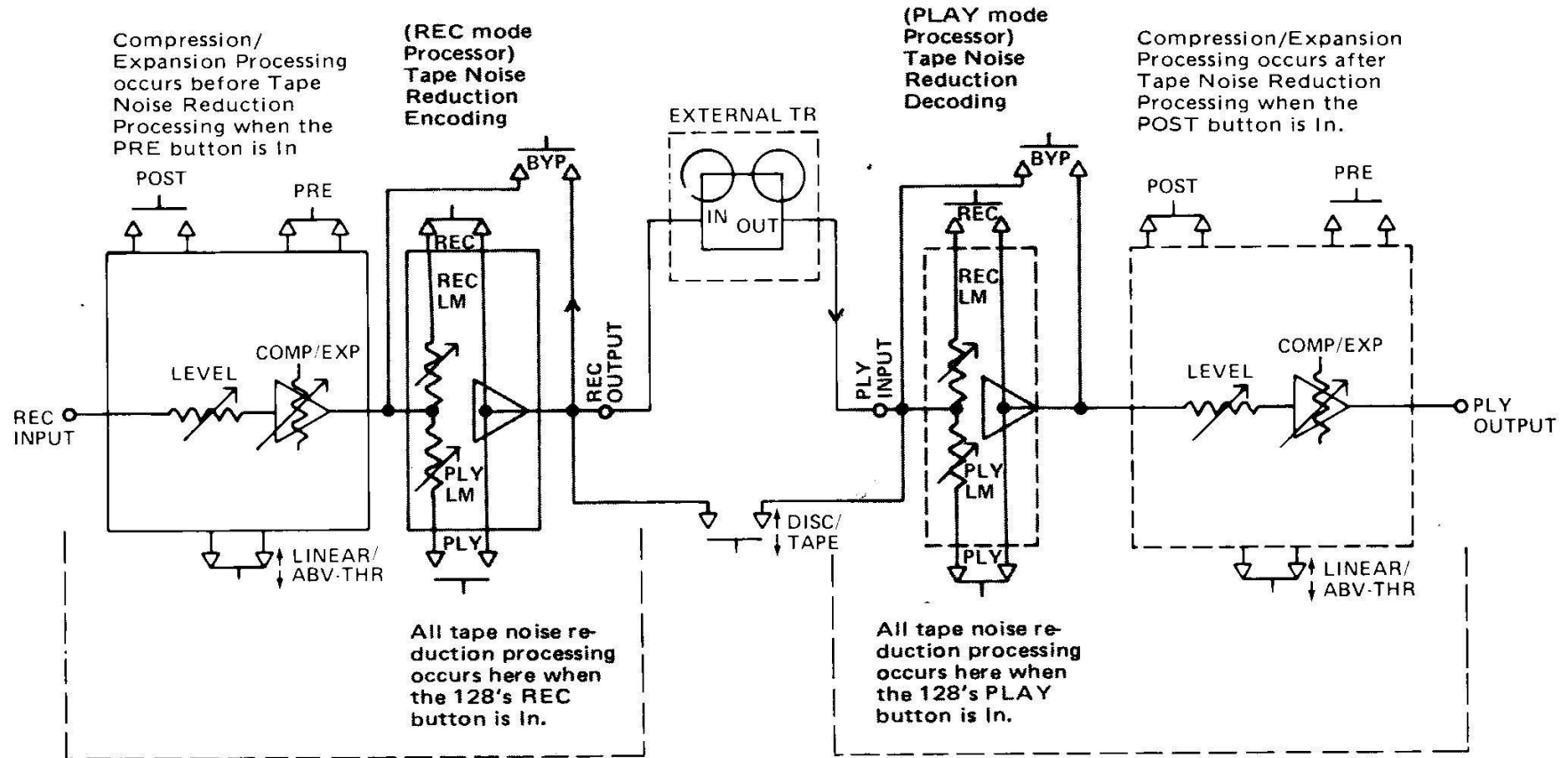

Fig. 14 – Signal Flow Diagram

dbx II Tape Noise Reduction REC and PLAY processing always stays in the same position relative to the tape machine. However, compression/expansion processing may be done before or after tape noise reduction processing, depending on the setting of the PRE and POST buttons. (NOTE: Lines show signal flow, not actual connections.)

HOW dbx II TAPE NOISE REDUCTION WORKS

A Short Explanation

To reduce tape noise, the dbx 128 utilizes a sophisticated version of the classical compressor/expander (componder) concept. The RECORD processor compresses the input to the tape recorder by a 2:1 ratio, linear over a 100 dB range. Upon playback, the PLAY processor provides 1:2 expansion

of the recorder's output. The expansion is a mirror image of the compression so the recorded signal cannot be distinguished from the original audio source, full dynamics have been preserved, and virtually no audible tape noise has been added.

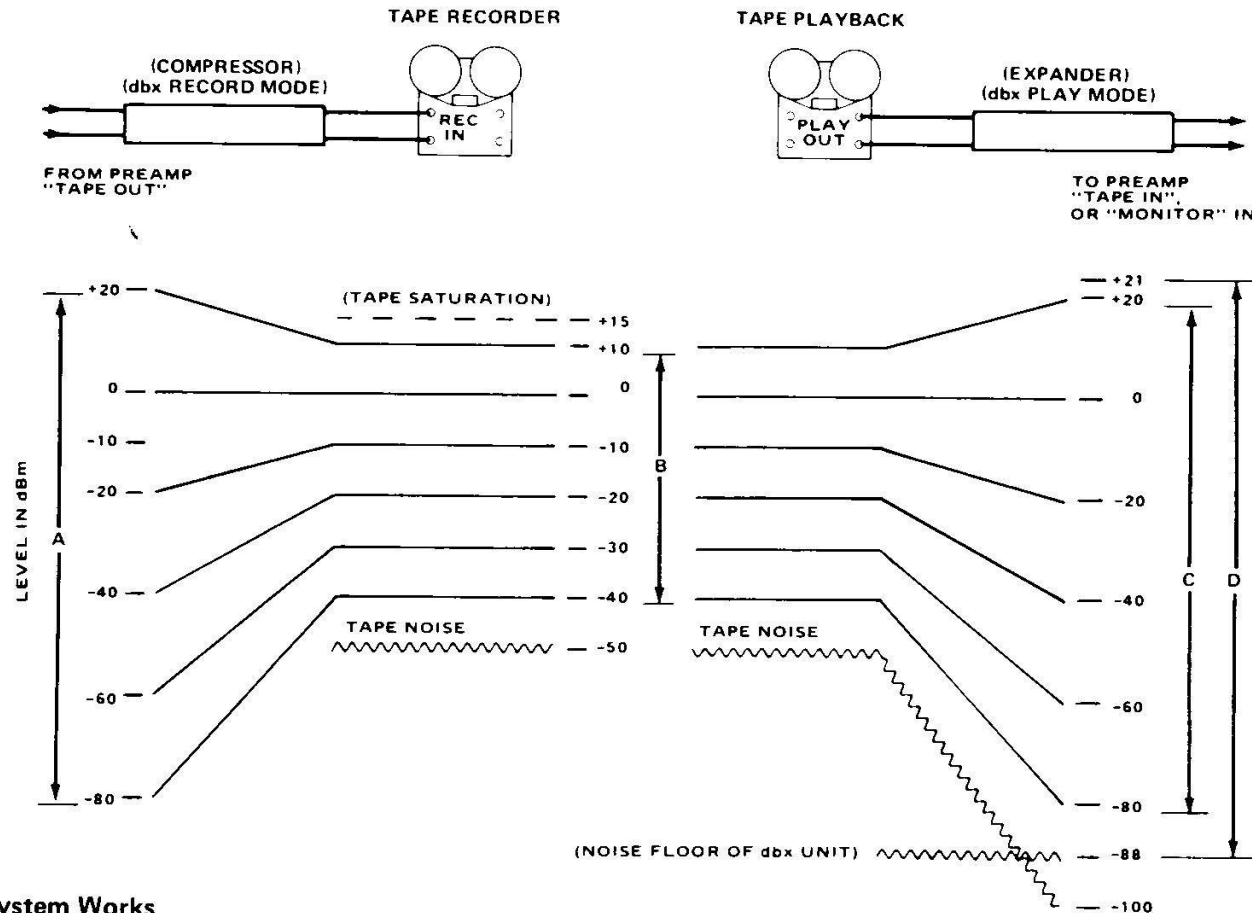

Fig. 15 – How the dbx System Works

- A. Typical program of wide dynamic range (about 100dB).
- B. 2:1 compressed program (encoded) reduces dynamic range by half, so that signal can be placed below the tape saturation level and above the tape noise level.
- C. 1:2 expanded program (decoded) restores the original dynamic

- range (100dB). Tape noise is always well below the quietest part of the program.
- D. Dynamic range of the dbx compressor and expander is about 100dB.

Consider a 100 dB program which might have loud peaks at +18 dBm (6.16 volts) and quiet passages as low as -82 dBm (61.6 microvolts).* If the tape recorder has a maximum input level of +15 dBm (4.36 volts) before distortion and a residual noise level of -40 dBm (7.75 millivolts, a millivolt is one-thousandth of a volt) (in other words, a 55 dB S/N ratio which is typical of many good hi-fi and semi-pro tape machines), there is no way the original program dynamics can be captured on tape; peaks will be lost due to saturation, quiet passages will be lost in the noise, or a combination of both. dbx encoding (compression) will solve this problem by bringing the maximum signal level down to +9 dBm (2.18 volts), and by raising the minimum level to -41 dBm (6.91 millivolts) (compression by a factor of 2:1), so the recorded program would fall within the usable dynamic range of the tape. (See Figure 15) That is, the quietest signal remains above the noise and the loudest signal remains below the point of tape saturation.

NOTE: Maximum input levels on tape recorders are specified at the 3% harmonic distortion point; because dbx encoding lowers maximum recorded levels, it greatly lowers distortion at the same time it eliminates audible noise.

When the encoded recording is played through the dbx PLAY circuitry, expansion increases the level of the louder

**The term "dB SPL" is discussed on page 4, and refers to the acoustic sound pressure level. The term "dBm" refers to the level of "sound" while it is in electrical form. dB is a relative term, and there is no direct equivalence of dB SPL to dBm, although the terms are proportional. That is, an electrical increase of 1dBm in an amplifier will create an acoustical increase of 1dB SPL in front of the speakers. Thus, a live program might increase from 50dB SPL to 100dB SPL. When translated to an electrical signal by a microphone, the same program might go from -40dBm to +10dBm . . . still a 50dB increase in program level.*

passages, and decreases the level of quieter ones. In the preceding example, the +9 dBm (2.18 volts) recorded level would be restored to +18 dBm (6.16 volts), the -41 dBm (6.91 millivolts) level would be restored to -82dBm (61.6 microvolts), and all other levels in between would be proportionately restored (see Figure 15). The tape noise is also subject to expansion, and it drops from -40 dBm (7.75 millivolts) to -80 dBm (77.5 microvolts) . . . to inaudibility.* This type of processing for tape recording is far more effective than filters which operate only during playback of conventional recordings (like the rumble and scratch filters on your receiver or amplifier). Moreover, such playback-only filters may cut off the higher frequency program harmonics in order to reduce hiss, whereas dbx II processing retains the full frequency spectrum of the original program.

Many attempts have been made to apply the classical compression/expansion concept to tape noise reduction, but most of these have been less than successful for technical reasons. The dbx approach, however, is unique. A voltage controlled amplifier (VCA) serves as the gain control element, and a true RMS (Root-Mean-Square) level sensing detector insures perfect encode/decode tracking for accurate transient response . . . regardless of phase changes that may be induced by the tape machine. Moreover, there is no audible breathing, pumping, or other coloration of the sound. Critical level matching is not needed because the 128 encodes and decodes accurately despite differences in record and playback levels.

The Two dbx Systems: dbx (professional), and dbx II

The original dbx noise reduction system was developed for use in professional recording studios. With the increasing popularity of dbx noise reduction in models like the 4-chan-

**A microvolt is one millionth of a volt.*

nel 187 and the 16-channel 216, many home recording enthusiasts sought better quality tapes. In response to the demands of consumers and small studios, dbx introduced a variety of semi-professional units (the 150 series). These units utilize the same signal processing as the professional recording studio models, so tapes made with the professional series may be decoded with the semi-professional series, and vice-versa.

Broadcasters realized the potential for improved signal quality if they could use dbx processing. However, broadcast cartridges and telephone transmission lines do not offer the excellent frequency response available in professional recording studios and better hi-fi tape machines; the low and high end of the frequency spectrum often fall off considerably. Poor frequency response in a tape recorder can cause mistracking of the RMS detection circuitry in the dbx professional system. The rumble and low frequency errors of warped discs, or the limited low and high frequency response of telephone and microwave transmission lines would create mistracking of the RMS detection circuitry. Therefore, the dbx II system was developed, represented by dbx models 122, 124, 128 and the 142. The basic principle of operation of dbx professional and dbx II are identical, and the amount of noise reduction is the same, yet the two systems are not compatible. A tape encoded with either system cannot be decoded by the other. Similarly, a dbx encoded disc (dbx II processed) cannot be decoded with the original dbx professional system.

The two systems were designed for different applications. The bandpass filter in the signal path in the dbx II system is slightly more restrictive, rolling off 1 dB at 30 Hz. In addition, the RMS detection circuitry in dbx II units is sensitive only up to 10 kHz, so high frequency losses on the tape or transmission lines will not create encode/decode mistracking. THE

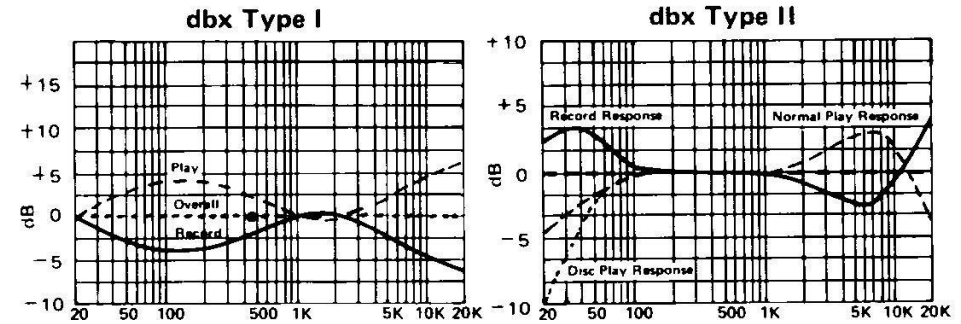

Fig. 16 – Comparison of dbx Type I and Type II Processing

Type I is the curve used in the 152 and 154, as well as professional recording studio dbx equipment. Type II is the curve used in the 128, 122, 124 and 140 series, which is optimized for such applications as broadcast and disc noise reduction, as well as tape recording.

OVERALL FREQUENCY RESPONSE OF dbx II PROCESSING DOES COVER THE ENTIRE AUDIBLE SPECTRUM.

The dbx II system is also equipped with a TAPE/DISC switch that introduces a further low end roll off (-3 dB @ 30 Hz) in DISC mode. This has been provided to permit decoding of special dbx encoded phonograph records; the roll off protects the RMS detection from mistracking due to record warp or turntable rumble. The dbx II system is especially suited to noise reduction with cassette and cartridge recorders which have limited frequency response compared to a professional studio machine.

A few minor changes in the pre-emphasis and de-emphasis curves also distinguish the dbx professional and dbx II systems. However, both systems offer the same 30 dB of broadband noise reduction, and a 10 dB improvement in headroom for tape recordings. The signal processing differences between dbx professional and dbx II make it inadvisable to encode with one system and decode with the other; audible tracking errors could occur.

Close scrutiny of a dbx processed tape will demonstrate that its frequency content is virtually identical to that of the original source. However, the first impression of a dbx II processed tape when compared with a non-dbx II processed tape, may seem to indicate that the non-processed tape has better high frequency response. This apparent contradiction can be explained by realizing that the ear has interpreted the hiss of the non-processed tape as additional high frequency content.

There can be some barely audible imperfections, even after dbx tape noise reduction processing, which are due to tape asperity noise with some types of very clear signals.* Unfortunately, these noise components lie in the same frequency region as the dominant signal energy, hence we must look to improvements in tape technology for their reduction . . . regardless of the noise reduction system in use. Incidentally, these asperity noise components can be masked, almost completely, by a steady hiss. The required level of this "noise perfume" is about -65 dBm. It is no coincidence that noise reduction systems such as Dolby A, Dolby B, and A.N.R.S., which claim "absolutely no audible effect", have this residual noise present in the output (dbx output noise is below -88 dBm).

By taking advantage of dbx noise reduction in live recording, not only will there be no hiss, there also will be full

**Asperity noise is a random noise that is caused by minute imperfections in the magnetic coating of the tape. Due to surface irregularities and magnetic particles that vary in size, tape becomes more or less magnetized in a given field from the recording head, causing a random noise to be superimposed on the recorded signal. The noise due to this non-homogeneous coating cannot be subtracted from the signal by compander processing. Improvements in tape manufacturing processes could reduce asperity noise. To draw a rough analogy, asperity noise is to a taped program as grain is to a photograph.*

dynamics in the live recording. Moreover, the distortion that would otherwise have been introduced by tape saturation or transient overload will not act to degrade the audio quality.

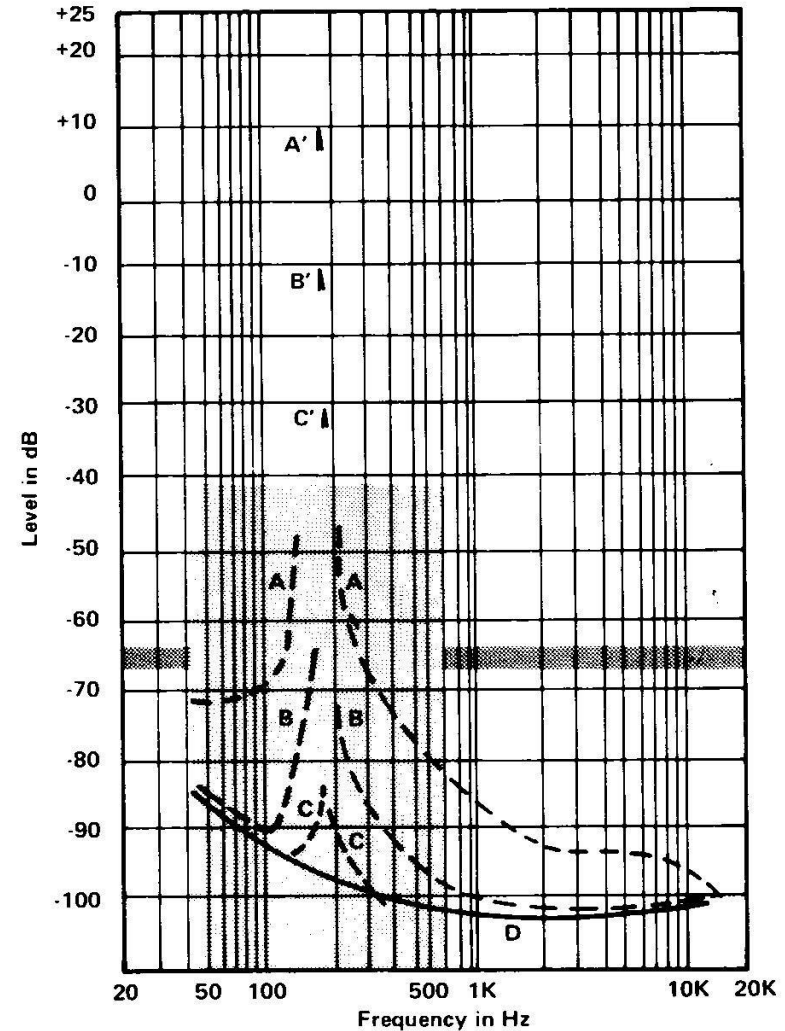

Fig. 17 – Tape Noise Characteristics (description next page)

Tape Noise Characteristics (Refer to Figure 17)

Asperity noise yields the curve shown by "D". The recorded signals (A', B' and C') are all sine waves at 180Hz. The noise sidebands created by these signals are illustrated by curves A, B and C. Observe that the higher the recorded signal level, the higher the noise sideband level. This level dependent noise is known as tape modulation noise.

The noise sidebands are masked partially by the recorded signal, but only for about two octaves on either side of the signal. This masking is depicted by the shaded box in the chart. The ear is less sensitive to lower frequencies, so the lower sidebands are masked sufficiently by the signal. Notice the upper sideband of the +10dBm recorded signal (curve A) extends beyond the masked area and at a level which would be audible in a program of 100dB dynamic range.

To negate modulation noise effects, dbx applies pre-emphasis to the signal before recording and de-emphasis upon playback. The de-emphasis starts at 400Hz, and reaches a maximum weighting of -12dB at 1600Hz (see Figure 18). The net result is a reduction in modulation noise of nearly 12dB with strong low frequency recorded signals, while the overall record/play frequency response is flat.

The shaded line at -65dBm indicates the level of steady state background noise which would be required to mask modulation noise if pre-emphasis and de-emphasis (or signal weighting) were not used. With signal weighting, there is no need for this "noise perfume" as used in other compander systems.

Level Detection

Regardless of the specific techniques employed by a given compander-type noise reduction system, some method must be used to sense the audio input level to the compressor (when recording) and to the expander (when playing back) (Fig. 18, 6&6A). This level detection circuitry tells the compressing or expanding amplifier (Fig. 18, 3&3A) what the actual input signal level is, and then the amplifier's gain increases or decreases to accomplish the required expansion or compression. In theory, the basic principle of operation is simple, but in practice, the difficult part is to maintain precise mirror image encoding and decoding. In other words, whatever degree of compression takes place during the encoding must be precisely matched by the same degree of expansion during decoding . . . and at the same point in time with respect to the program. There are several ways to detect signal level, and some make it difficult to assure mirror image encode/decode performance (tracking).

Previous attempts to create compander type tape noise reduction systems have utilized peak or average level detection, both of which are sensitive to phase changes. Phase changes are inherent in tape recording due to characteristics of the record heads, electronics, and tape, so level detection schemes which are phase sensitive are subject to mistracking errors upon decoding. That is, the amount of expansion does not correspond with the original compression so the retrieved program does not sound exactly like the original one. Unlike peak and average level detection systems, the RMS method sums the squares of the instantaneous energy of all frequency components present. Therefore, RMS detection is impervious to phase changes. However, true RMS detection has been very complex and expensive. dbx equipment uses our own recently developed and patented analog techniques to achieve excellent RMS detection at a moderate cost.

Bandpass Filtering

To further improve the performance of the dbx system, bandpass filters are placed in the signal path, restricting the response to the audible frequency spectrum. This does not degrade the audio signal's frequency response in any way. Bandpass filters are also placed in the RMS level detection path (Fig. 18, 4 & 4A) so that subsonic and supersonic signals (such as air conditioning noise or tape bias noise) are less likely to create encode/decode mistracking.

Pre-Emphasis & De-Emphasis

Tape modulation noise is a phenomenon that occurs with all tape recordings. It consists of noise sidebands which appear on either side of the signal which is being recorded, and it is caused by inherent characteristics of the tape. Modulation noise levels are significantly higher than the residual background noise of the tape, although the modulation noise falls off as the frequency moves away from the recorded signal. The signal masks modulation noise components that lie nearby in frequency, but it does not mask noise which is several octaves above. For this reason, modulation noise is most often a problem when a strong, low frequency signal is recorded (what might be heard, for example is a low organ or bass guitar note that is accompanied by a rushing, hissing sound . . . as the note dies, so does the noise). dbx applies pre-emphasis and de-emphasis to reduce modulation noise by up to 12dB (Fig. 18, 2&2A).

Levels

When using linear compression and expansion there is no threshold at which the compression and expansion takes place. Therefore no pilot tones or routine calibration are required. The 128 is provided with a REC LEVEL MATCH control, and a PLAY LEVEL MATCH control. These controls adjust the dbx record and play gain to correspond to

the nominal levels of your equipment. These level adjustments let you maintain the same levels in record, play and bypass modes for monitoring convenience. Level matching is not essential for proper encode/decode tracking. (Refer to pages 2, 3, 4 & 15 for level adjustment information.)

Fig. 18 – Block Diagram of dbx II “Noise Reduction Circuitry”
(Diagram on next page)

A. The Signal Bandpass Filter

With a 3dB roll off at 20Hz and at 27kHz, this filter prevents non-recordable signals from entering the dbx record processor. It does not affect the audible spectrum, but it does prevent encode/decode mistracking by preventing subsonic and supersonic signals from entering the compander.

B. Record Signal Pre-Emphasis

A high frequency boost that matches reciprocal high frequency reduction upon decoding (curve F), thereby reducing modulation and asperity noise.

C. Level Detector Bandpass Filter

The same filter is used for encoding and decoding, and rolls off 3dB at 27Hz and 10kHz. The filter affects only the RMS level detection, preventing expansion and compression circuits from reacting to subsonic or supersonic signals or from being misled by poor frequency response in the tape recorder at the extremes of the audio spectrum. This avoids encode/decode mistracking without affecting overall signal frequency response.

D. RMS Level Detector Pre-Emphasis

The same RMS Level Detector pre-emphasis curve is used for encoding and decoding. It complements the signal pre-emphasis and de-emphasis curves, avoiding excessive high frequency levels which might otherwise cause tape saturation or self-erasure.

E. Overall Record Processing (Encode) Response

This is the single sine wave response of the encoding circuitry. Given a nominal level input at the dbx 128 input (a sine wave signal swept across the audible spectrum), this is what the dbx record output will do. Note that the overall encode and decode response (curve H) is essentially flat.

F. Play Signal De-Emphasis

The complementary curve for the record signal pre-emphasis (curve B), containing a high frequency roll off to reduce modulation and asperity noise components by some 12dB.

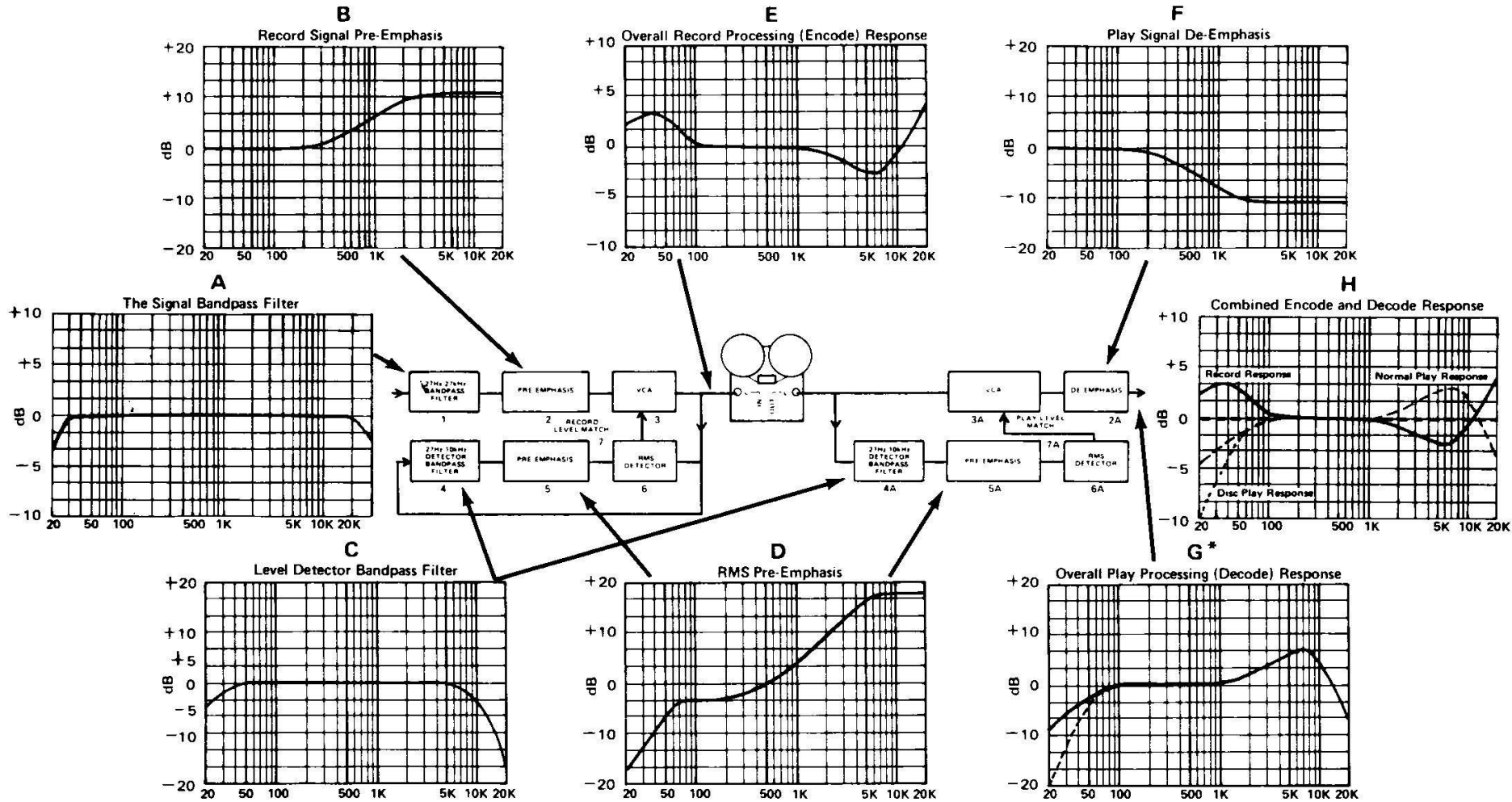

*dotted line - disc
solid line - tape

G. Overall Play Processing (Decode) Response
 This is the single (swept) sine wave response of the decoding circuitry. Given a nominal level input at the dbx 128 input (a sine wave signal swept across the audible spectrum), this is what the dbx play output will do. Note that the overall encode and decode response (curve H) is essentially flat, a combination of the PLAY and RECORD response (curve E plus curve G).

H. Combined Encode and Decode Response
 This is the combined effect of encoding and decoding, and shows that the net result of dbx processing does not change the frequency content of the program. The only thing missing is the noise and much of the distortion that would otherwise be introduced as a result of the tape recording process. (Note: Play curve's vertical scale is corrected for the 1:2 expansion factor.)

Compressor

A variable gain amplifier whose gain decreases as its input level increases. A compressor uses low compression ratios such as 2.0 to 4.0 (selected by the EXPANSION/COMPRES- SION control). In the LINEAR mode, the 128 decreases gain above the threshold point (the threshold point is set by the LEVEL control) and increases gain below the threshold point (see figure 19C). In the ABOVE THRESHOLD mode, the 128 decreases gain above the threshold point, and does not act on levels below the threshold point (see figure 19D).

Peak Limiter

A compressor with a high compression ratio, such as 10.0 or greater. The high ratio maintains essentially constant out- put level despite any increase in input level above the thresh- old. While the 128 can be used in the LINEAR mode with high compression ratios, it would normally be used in the ABOVE THRESHOLD mode with high compression ratios, making it a peak limiter (acting to limit only musical peaks).

Expander

A variable gain amplifier whose gain increases as its input level increases. An expander normally uses low expansion ratios such as 1.2 to 1.5 (selected by the EXPANSION/COM- PRESSION control). In the LINEAR mode, the 128 increases gain above the threshold point (the threshold point is set by the LEVEL control) and decreases gain below the threshold point (see Figure 19A). In the ABOVE THRESHOLD mode, the 128 increases gain above the threshold point and does not act on levels below the threshold point (see Figure 19B).

Peak Unlimiter

A peak unlimiter is an expander with a high expansion ratio such as 1.4 to 1.6 which is used to counteract the

effects of peak limiting described above. Although the 128 works best with moderate expansion ratios while in the LINEAR mode, HIGH EXPANSION RATIOS WOULD NORMALLY BE USED TO PROVIDE PEAK UNLIMITING IN THE ABOVE THRESHOLD MODE.

How the 128's Compression/Expansion Circuits Work

An expander or compressor is made by combining two devices. One device changes the level of the audio (by chang- ing its gain), and the other senses the audio level to control the gain change. The 128 uses VCA's (voltage controlled amplifiers) to change the level. The VCA gain is linearly pro- portional, in dB, to the controlling voltage. The 128's level sensing devices respond to the RMS (root-mean-square) value of the sum of the stereo input signals, converting that RMS value to a D.C. (direct current) control voltage, which changes in proportion to the dB change of input signal. Depending on the setting of the COMPRESSION/EXPANSION control (i.e. compress or expand) the polarity of the control voltage is reversed (to plus or minus), and the fraction of a volt per dB of level change is varied. The control voltage is fed to the VCA where it modifies the audio level appearing at the 128's outputs.

RMS level sensing is used, rather than peak or simple average sensing, for several reasons. First, the human ear and brain perceive loudness in a way that more closely follows the RMS value than any other value. Thus, when the 128 expands or compresses, it does so on the same basis the human ear uses to determine loudness. In contrast, a peak sensing system would respond to short-term transients that do not contribute to loudness and can lead to audible dis- tortion. RMS level sensing results in very natural changes in level.

A particularly interesting feature of linear decibel com- pression and expansion is that it works evenly over the entire

dynamic range at all times, regardless of level. This means that the gain changes are very gradual, spread evenly over the dynamic spectrum. Non-dbx systems which concentrate gain changes only at the upper or lower end of the dynamic range must, necessarily, cram a lot of gain change into a small area. Obviously, the audio quality cannot benefit from such processing. Furthermore, the use of a threshold-type system necessitates tricky compression/expansion adjustment that would require repeated attention with almost every new program. The linearity of the dbx system means

such matching is unnecessary (the PLAY LEVEL MATCH feature is more for the benefit of "A-B" comparison than anything else).

The peak unlimiting capability (or peak limiting capability) of the 128 is a special purpose feature. When the 128 is in the ABOVE THRESHOLD mode, it operates by "ignoring" all data below the preset THRESHOLD level (set by the LEVEL control). Above that level, the compression or expansion works just as when the 128 is in its LINEAR mode.

Fig. 19 – Compression/Expansion

A. Linear expansion operates over the entire dynamic spectrum of music irrespective of frequency (20-20,000Hz), making loud passages louder and quiet passages quieter, reducing audible noise. Expansion ratios are adjustable. For example: 1.0 = 0% increase in dynamic range; 1.2 = 20%; 1.5 = 50%; 2.0 = 100%.

B. Above threshold expansion is used to make loud passages louder above a user adjustable threshold level when no low level dynamic alteration is desired.

C. Linear compression reduces the entire dynamic range of the music irrespective of frequency (20-20,000Hz).

D. Above threshold compression has no effect on low level signals. When signal level reaches the adjustable threshold, the dynamic content of the music is decreased but only above that threshold. Higher compression ratios may be used in above threshold compression than in linear compression; however, all ratios are available.

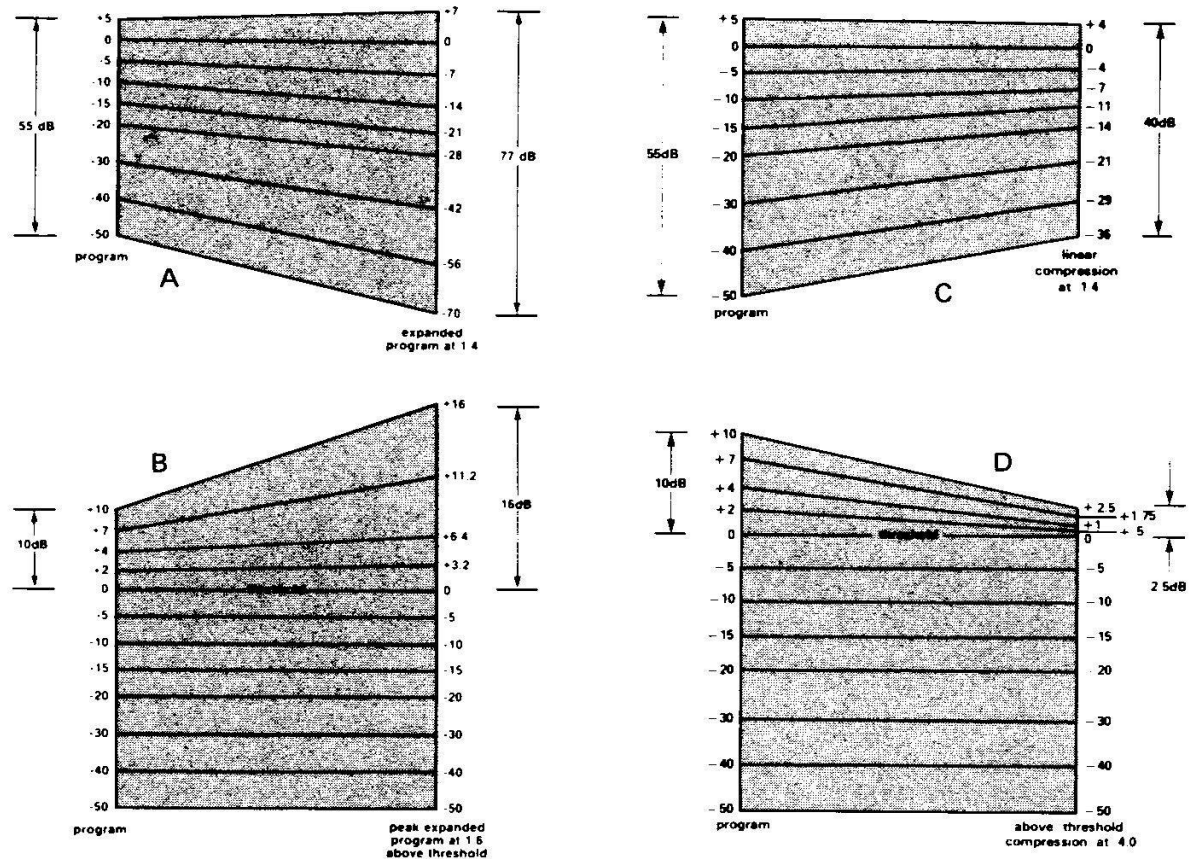

SIMPLE PRECAUTIONS WHEN USING ANY PROGRAM EXPANDER

The 128 (or any expander) places greater demands on your power amplifier and speakers. Whether or not a given amplifier is of adequate power rating is not always easy to determine; it depends partially on the sensitivity of the speakers, and partially on the distortion characteristics of the amplifier.

With most bookshelf speakers, average listening levels of 85 dB SPL can be achieved with 1 watt of power (per channel). Very quiet passages of 55 dB SPL (30 dB below average) would require only 1 milliwatt (1/1000-watt) from the amplifier, yet very loud passages of 105 dB SPL (20 dB above average) would require 100 watts from the amplifier. In other words, to produce a dynamic range of 50 dB, the amplifier swings between 1 milliwatt and 100 watts. High sensitivity studio monitor speakers produce about 98 dB SPL for a 1 watt input (at 1 meter distance from the speaker). With a 300-watt amplifier, and a 10 dB allowance for peaks, one of these studio monitors can produce a maximum of about 113 dB SPL.

Set for 1:1.5 expansion, the 128 will expand a good 60 dB classical recording to about 90 dB of dynamic range. Full realization of the benefit of this dynamic range requires both a hefty power amplifier and speakers that can take the high power. If you have such equipment, the results will be breathtaking. Fortunately, such components are not mandatory for full enjoyment of the 128.

The most important point is this; if the speakers and amplifier cannot handle wide dynamic range, and if the expander "tries" to drive them to a wide dynamic range, excessive clipping distortion (overdrive) may occur. To avoid this unpleasant effect, use decent speakers and a reasonably large amplifier. If distortion still occurs, it will probably be noticed only with programs that have a good dynamic range to begin with, and which do not need expansion to much

greater dynamics. In such cases, a reduction in the expansion ratio setting will avoid distortion. A good expander is a powerful tool, and, as with any powerful tool, it can be used to excess. Used properly, the expander can turn an old record collection into a treasure of new listening enjoyment, and it can turn a boring selection of compressed and limited FM broadcasts into an exciting new source of listening pleasure.

SPECIFICATIONS

36

dbx II Tape Noise Reduction Section

| | |
|------------------------------------|--|
| DYNAMIC RANGE | 110dB (unweighted background noise-to-peak signal ratio) |
| INPUT IMPEDANCE | 50k-ohms |
| OUTPUT IMPEDANCE | Designed to feed tape recorder inputs 5k-ohms or greater. |
| MAXIMUM OUTPUT LEVEL | 7 volts RMS at 1kHz into 5k-ohm load |
| EFFECTIVE NOISE REDUCTION | 30dB for tape recorders with a signal-to-noise ratio greater than, or equal to 45dB 40dB for dbx-encoded discs (A weighted) |
| COMPRESSION/EXPANSION SLOPE | 2:1 constant linear decibel |
| TRACKING ACCURACY | ±1dB per 20dB for record/playback cycle |
| LEVEL ADJUSTMENTS | 100 millivolts to 3 volts for unity gain; for convenience in level setting and avoidance of overload in succeeding audio stages; level setting unimportant for record/playback tracking. |
| FREQUENCY RESPONSE | ±0.5dB, 50Hz to 15kHz ±1dB, 30Hz to 20kHz: single sinewave record/playback cycle ±0.25dB, 30Hz to 20kHz for complex music program -3dB at 20Hz for tape noise reduction; -3dB at 27Hz for disc playback mode |
| LEVEL ADJUSTMENT | 100mv to 3V for Unity Gain; for convenience in level setting and avoidance of overload in succeeding audio stages; level setting unimportant for record/playback tracking. |
| HARMONIC DISTORTION | 2nd harmonic distortion less than or equal to 0.1% for record/playback cycle from 30Hz to 15kHz 3rd harmonic distortion less than 0.1% for record/playback cycle from 100Hz to 15kHz 3rd harmonic distortion less than 0.5% for record/playback cycle from 30Hz to 15kHz |
| IM DISTORTION | 0.15% typical; 0.3% maximum (using 60Hz and 7kHz at a ratio of 4:1 per SMPTE method) |
| IMPULSE RESPONSE | Risetime is less than 20 microseconds. Release rate - 240dB/second. |

NOTE: All above measurements were made with a 1 volt RMS input and output signal.

Specifications continued on next page.

Dynamic Range Enhancement Section

| | |
|-----------------------------------|---|
| COMPRESSION | Continuously adjustable to infinity |
| EXPANSION | Continuously adjustable from 1.0 to 2.0 |
| INPUT NOISE | 90dB below 1 volt |
| INPUT LEVEL | 30 volts RMS maximum |
| INPUT IMPEDANCE | 50k-ohms |
| MAXIMUM OUTPUT LEVEL | 7 volts RMS at 1kHz into a 5k-ohm load |
| THRESHOLD LEVEL ADJUSTMENT | Adjustable for unity gain for signal levels of 10 millivolts to 2 volts. |
| FREQUENCY RESPONSE | ±0.5dB 20Hz to 20kHz |
| ATTACK TIME | 12 milliseconds typical; faster for rapidly rising signal level. |
| RELEASE RATE* | Follows signal envelope up to a rate of 180dB per second. Attack and release times vary with the rise and decay of a musical signal. Time responses optimized to simulate the time response of the human ear. |
| TOTAL HARMONIC DISTORTION | 0.1% typical, 20Hz to 20kHz at 1.0 expansion setting |
| POWER REQUIREMENTS | 117 volts AC, 50 or 60Hz |
| POWER CONSUMPTION | 10 watts |
| DIMENSIONS | 11" wide (279.4mm); 10¼" deep (260.4mm); 3¾" high (95.25mm) |
| WEIGHT | 8 lbs (3.6kg) |

**Attack and release times automatically vary with rate of change of program level (attack and release times "track" the signal envelope).*

Specifications subject to change without notice or obligation.

SCHEMATIC

38

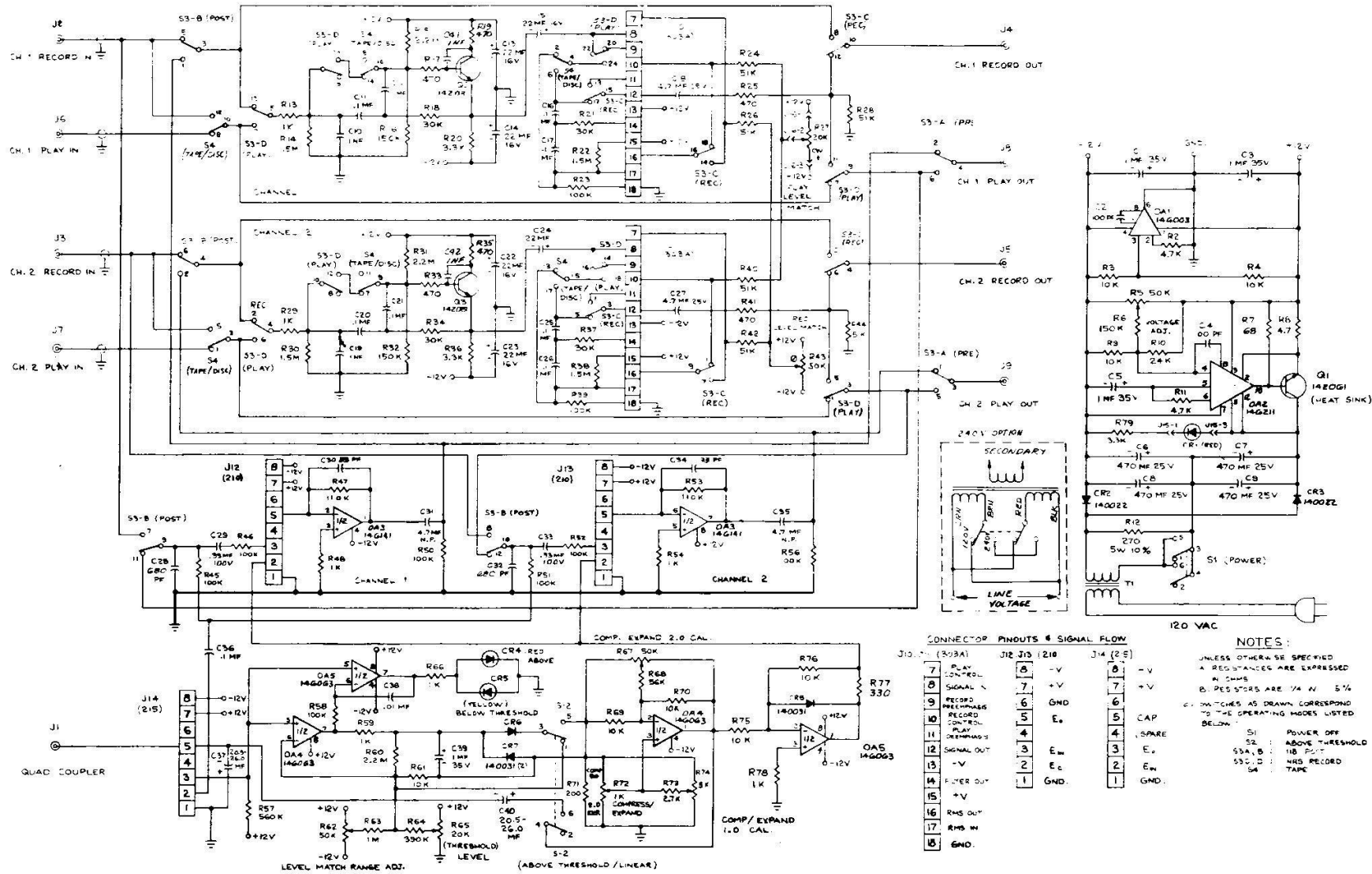

Manufactured under one or more of the following U.S. patents: 3,681,618; 3,714,462; 3,789,143; 4,101,849; 4,097,767. Other patents pending.

SCHEMATIC

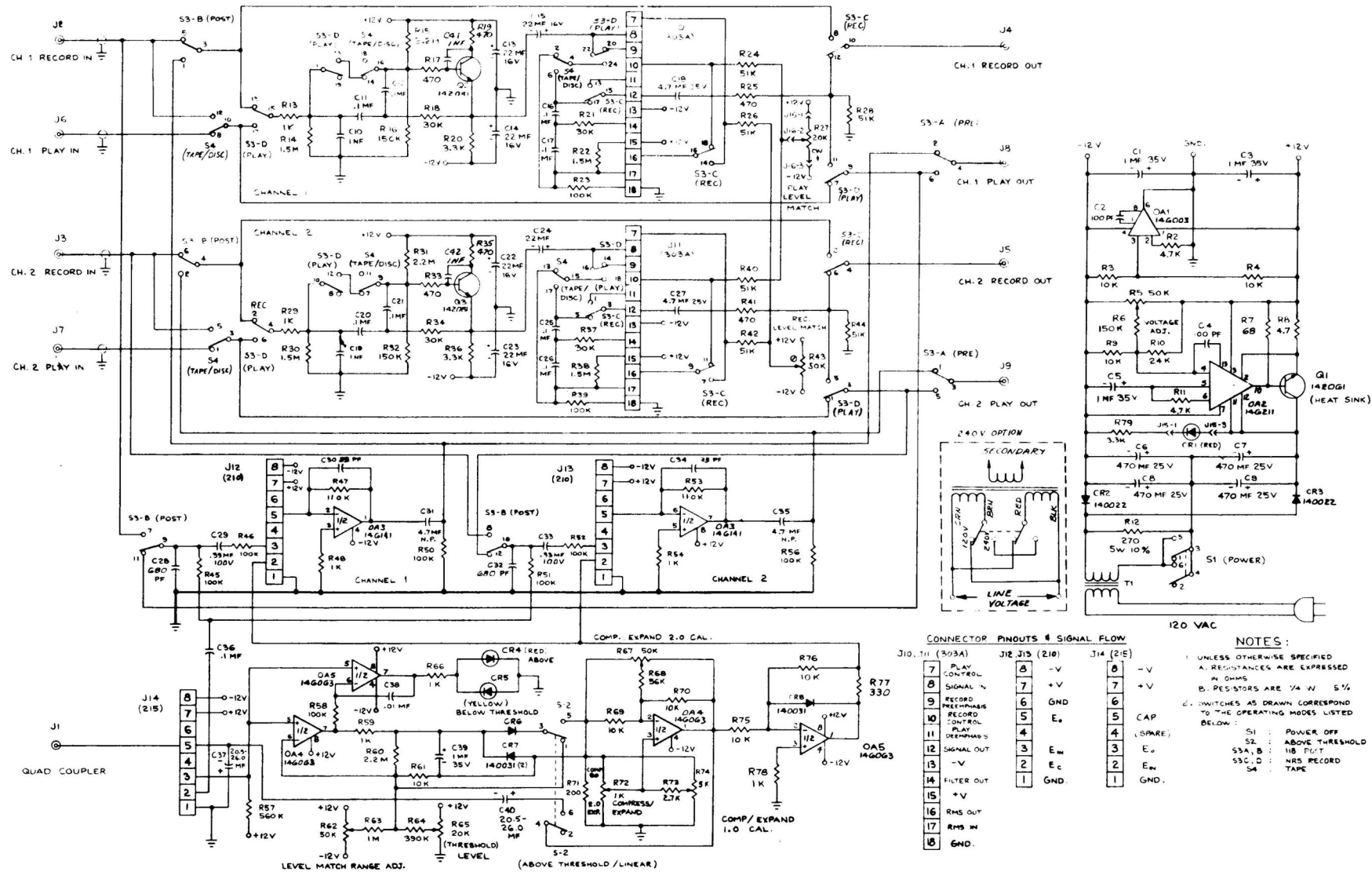

Manufactured under one or more of the following U.S. patents: 3,681,618; 3,714,462; 3,789,143; 4,101,849; 4,097,767. Other patents pending.

dbx PRODUCT WARRANTY

All dbx products are covered by a Limited Warranty. Consult your warranty card or your local dealer for full details.

FACTORY SERVICE

The dbx Customer Service Department is prepared to give additional assistance in the use of this product. All questions regarding interfacing dbx equipment with your system, service information or information on special applications will be answered. You may call during normal business hours — Telephone: 617-964-3210 or write to:

dbx, Inc.
71 Chapel Street
Newton, MA 02195
Attn: Customer Service Department

Should it become necessary to have your equipment factory serviced;

1. Please repack the unit including a note describing the problem along with the day, month and year of purchase.

2. Send the unit freight prepaid to:

dbx, Inc.
224 Calvary Street
Waltham, MA 02154
Attn: Repair Department

3. We recommend that you insure the package and send it via United Parcel Service wherever possible.

4. Please direct all inquiries to the dbx Customer Service Department.

Outside the United States — contact your nearest dbx dealer for the name of an authorized repair center.

dbx, Inc.
71 Chapel Street
Newton, MA 02195

Manufactured under one or more of the
following U.S. patents: 3,681,618;
3,714,462; 3,789,143; 4,101,849; 4,097,767.
Other patents pending.

4794.5M-600030

Printed in U.S.A.