

TOSHIBA

STEREO CASSETTE DECK

PC-D15



SPECIFICATIONS

Power Supply:	AC 220 V, 50 Hz AC 240 V, 50 Hz (for U.K. and Australia)	SN Ratio:	65 dB (SA tape) (Line, Peak, WTD DOLBY IN) DOLBY NR <IN> mode improves SN ratio by 5 dB and 10 dB at 1 KHz and over 5 KHz respectively.
Power Consumption:	25 W	Distortion:	0.7% (SA tape, 0 dB at 400 Hz)
Track System:	4-track 2-channel (stereo)	Frequency	Characteristic: 20 to 18,000 Hz (SA tape)
Recording and Erasing:	AC bias (85 KHz) AC erasure	Input Jacks:	MIC 0.25 mV (600 ohm to 10 K ohm) LINE 70 mV (over 50 K ohm)
Head:	AS head	Output Jacks:	LINE 0.4 V (50 K ohm) Headphone 0.2 mW (8 ohm)
Motor:	DC servomotor 1 DC motor 1	Dimensions:	257(W) x 104(H) x 204(D) mm (Including rubber feet and knobs)
Tape Speed:	4.8 cm/sec.	Weight:	5.1 kg
Fast Forwarding and Rewinding Time:	About 70 seconds (for C-60)	Accessories:	Connection cords (PIN-PIN) 2 Head cleaning rod 1 Dust cover 1
Adopted Semi-Conductors:	IC's 5 Transistors 61 Diodes 78		
Wow and Flutter:	0.04% JIS (WRMS)		

Specifications are subject to change without notice.

TE, TU, AY

CONTENTS

1. FEATUER	2
2. OPERATING CONTROLS	3 to 4
3. OPERATING INSTRUCTIONS	5 to 6
4. TECNICAL POINTS	6 to 9
5. DISASSEMBLY INSTRUCTIONS	10 to 12
6. BLOCK DIAGRAM	13
7. ELECTRICAL ADJUSTMENT	13 to 17
TEST EQUIPMENTS	13 to 14
RECORD/PLAYBACK HEAD AZIMUTH ADJUSTMENT	14
PLAYBACK SENSITIVITY ADJUSTMENT	15
BIAS LEAK ADJUSTMENT	15
LINE INPUT SENSITIVITY ADJUSTMENTS	16
LEVEL METER ADJUSTMENT	16
RECORD/PLAYBACK FREQUENCY CHARACTERISTIC ADJUSTMENT	17
RECORD/PLAYBACK SENSITIVITY ADJUSTMENT	17
8. P.C. BOARD PARTS LOCATIONS	18
9. SCHEMATIC DIAGRAM (MAIN)	19
SCHEMATIC DIAGRAM (METER DRIVE & LED BLOCK)	20
SCHEMATIC DIAGRAM (POWER SUPPLY BLOCK)	20
SCHEMATIC DIAGRAM (LOGIC BLOCK)	20
10. WIRING	21
11. CABINET PARTS LOCATIONS	22
12. MECHANICAL PARTS LOCATIONS	23
13. PARTS LIST	24 to 29

1. FEATURES

- Two motors and IC logic control.
Feather-touch operating buttons.
Direct button change without using the STOP button protects the tape.
 - Bar-graph peak meters with LEDs.
Electronically controlled bar-graph peak meters are more responsive, accurate, and easier to read than mechanical meters.
Levels below 0 dB are displayed in green and levels above 0 dB in red.
 - Automatic tape selector detects the chrome tape detection hole and automatically switches the mode from NORMAL to CHROME, and vice-versa.
Pushing the Fe-Cr switch enables automatic FERRO-CHROME and CHROME mode selection.
 - Many functions in a compact housing, such as a memory counter, automatic play, unattended recording, and alarm playback.
 - An all sendust (AS) head with new sendust laminated core assures low-distortion widerange recording.
 - Attractive all-aluminium housing, including the rear panel.
 - Direct loading allows easy and secure tape loading and unloading with a good view of the tape.
 - Dolby* system.
 - Remote control jack.
- * Noise Reduction System is manufactured under license from Dolby Laboratories Inc. "Dolby" and the double-D symbol are trademarks of Dolby Laboratories Inc.

2. OPERATING

FRONT V

Cassette Tape Com

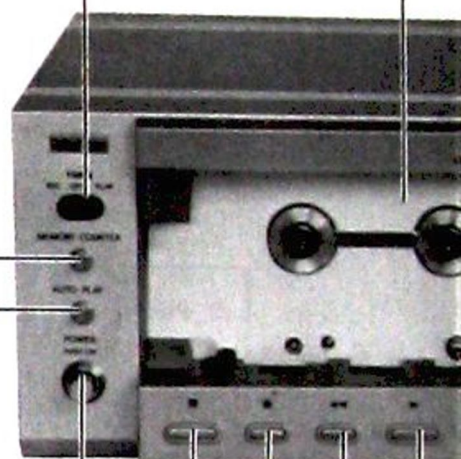

■ NAMES AND FUNCTIONS

[TIMER]

Unattended Recording and Alarm Playback Switch

Use this switch in combination with the timer for unattended recording and alarm playback. (Normally set to OFF.)

[MEMORY COUNTER]

Memory Counter Button

Push the counter reset button to set the counter to <000>, then push this button before recording or playback and the tape will stop at <999> when rewind.

[AUTO PLAY]

Automatic Play Button

Push this button when tape is rewind after recording or playback and the tape will restart from the tape end or the position specified by the memory counter (if the memory counter button is activated).

[POWER]

Power Button

The LEDs in the meter block go ON when this button is pushed.

Tape Operating Buttons

Tape operation can be changed directly by pushing the desired operation button without pushing the STOP button between operations. The tape is stopped automatically before the newly selected tape operation is actuated, protecting the tape.

Stop Button (■)

Record Button (●)

When recording push [●] (Record) and [▶] (Play) buttons simultaneously.

Rewind Button (◀◀)

Play Button (▶)

Fast Forward Button (▶▶)

Pause Bu

Push this button to suspend recording or playback. When pushed, the red indicator lamp goes off. When pushed again (released), the tape resumes. If this button is pushed while the tape is stopped, the indicator lamp goes on, and the deck is in standby.

To set the recording level, push the [●] (Record) and [▶] (Play) buttons simultaneously while the tape is in standby. After setting the recording level, push the [■■] (Pause) button again and recording

Figu

CONTROLS

EW

partment

**Tape Indicator**

The automatic tape selector detects the type of tape loaded, chrome <CrO₂> or normal <NORM>, and gives an LED indication. Push the [Fe-Cr] button when using ferrochrome tape and selection for ferrochrome <FeCr> or chrome <CrO₂> tape is made automatically, and an LED corresponding to the tape type goes ON. When no tape is loaded, the deck is ready for chrome tape operation.

Digital Meters

Indicate recording and playback level peaks.

[DOLBY NR]**Dolby NR Indicator**

This Indicator goes on when the [DOLBY NR] button is pushed.

[REC]**Recording Indicator**

This button goes on when the [●] (Record) and [▶] (Playback) buttons are pushed simultaneously.

Counter Reset Button**[RECORD]****Recording Level Controls**

Turn these controls to regulate line and microphone input levels. The front control is for the <LEFT> channel and the rear control is for the <RIGHT> channel.

[DOLBY NR]**Dolby NR Button**

Push this button to record in the Dolby system and to play back a Dolby recorded tape.

[Fe-Cr]**Ferrochrome Button**

Push this button when using ferrochrome tape. Push (release) this button again when using normal tape.

[PHONES]**Headphone Jack****[TAPE COUNTER]****Tape Counter**

ton (■ ■)
playback.
in. When
running.
pped, the
placed in

(Record)
the deck
vel, push
starts.

BACK VIEW

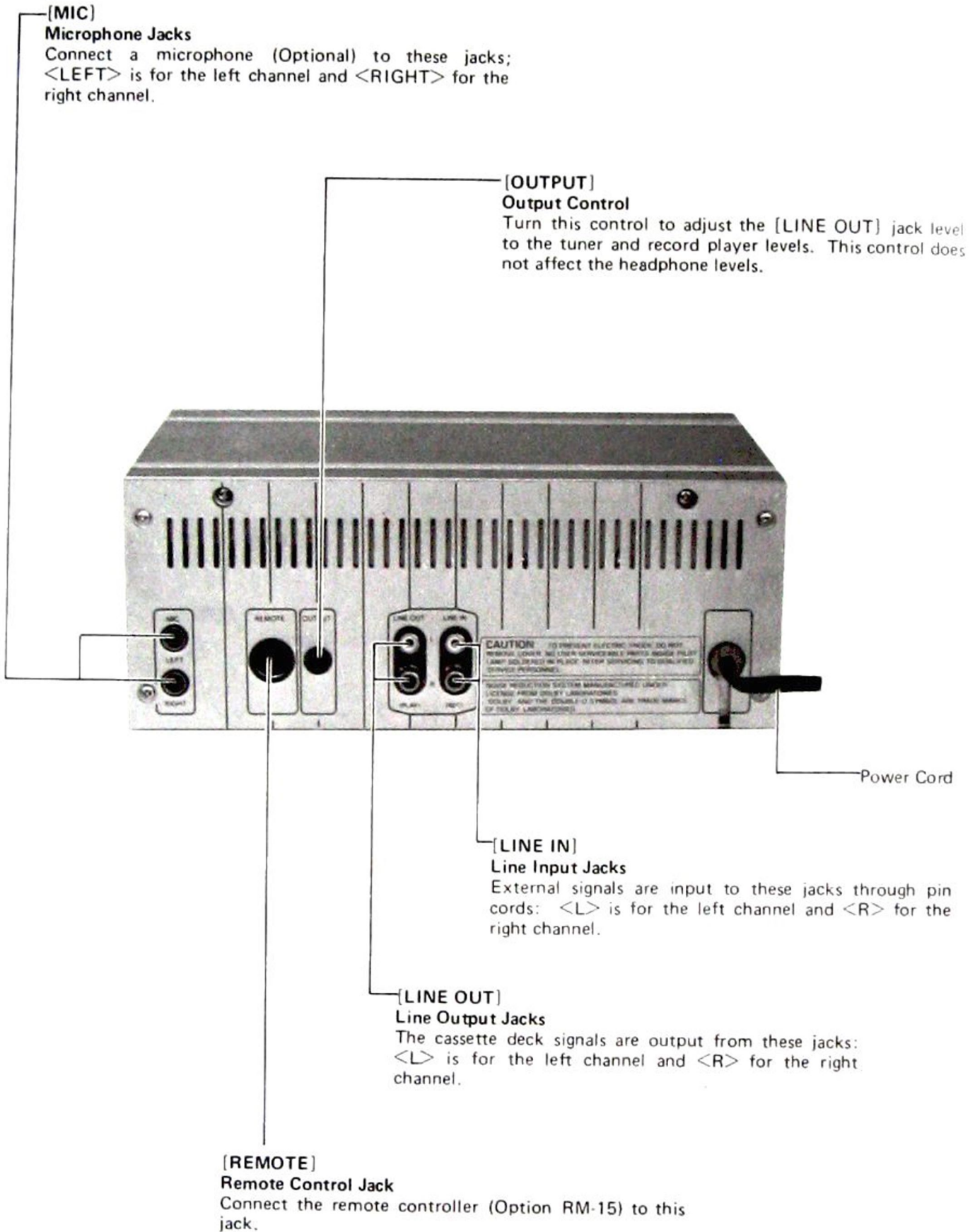

Note: The rating and serial number plate is on the bottom of the set.

Figure 2

3. OPERATING INSTRUCTIONS

Notes:

- Operating buttons are not effective for 3 seconds after the power is turned ON.
- All operating buttons are reset when power is cut OFF.
- All operating buttons are ineffective until a tape is loaded. If a tape is unloaded during fast forward (FF) or rewind (REW) operation, the operating buttons are reset.

■ PLAYBACK

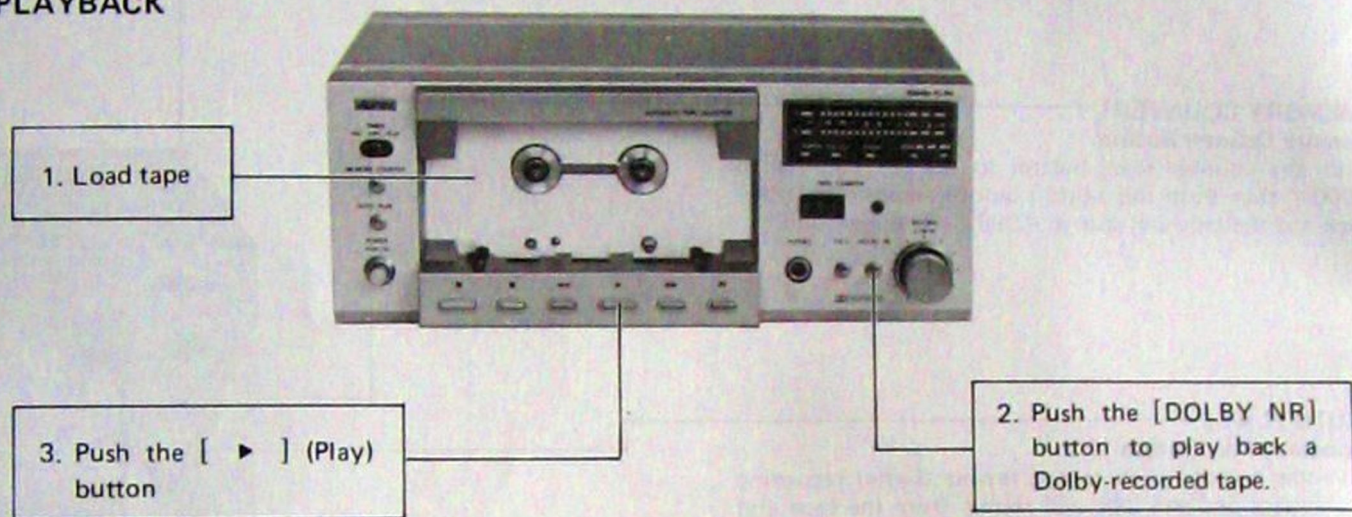

Figure 3.

- Push the [Fe-Cr] button when using ferrochrome tape.
- If the [||] (Pause) button is pushed, the [▶] (Play) button is not effective.
- The full automatic stop mechanism (Full ASO) stops recording, playback, fast forwarding, or rewinding when the tape end is sensed.

■ RECORDING FROM RECORD PLAYER OR RADIO

From amplifier



Figure 4.

- Push the [Fe-Cr] button when using ferrochrome tape.
- Adjust recording levels so that the red LEDs flicker in red (about 0 through +3 dB).

- #### ■ RECORDING WITH MICROPHONE
- Insert the microphone plugs into the microphone jacks [MIC] on the rear panel and perform the above procedure.
- The microphone jacks have priority to the [LINE IN] jacks if pin cords are connected to the [LINE IN] jacks.

CONNECTION

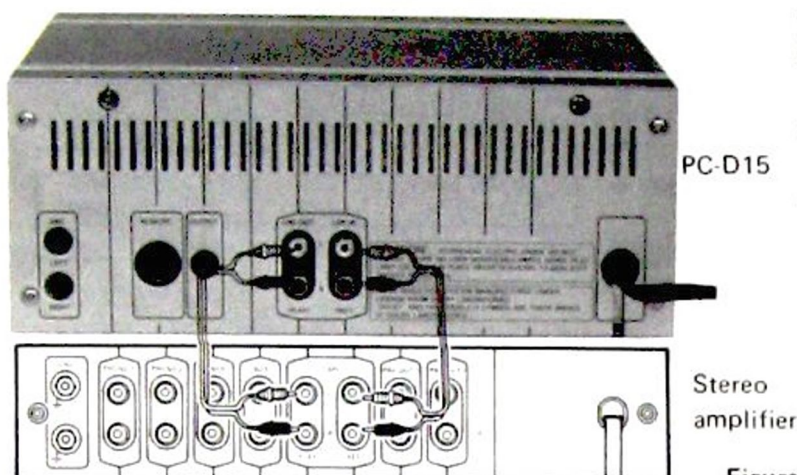

Figure 5.

Notes:

- Connect the connection cords (stereo pin cords) as shown above.
- Always use red plugs for the right channels for convenience.
- Cut off the amplifier power before making connections.
- Insert plugs fully to prevent noise.

4. TECHNICAL POINTS

IC LOGIC CONTROL

Features

1. Direct changeover of all operation modes. Changeover via the STOP mode is possible if necessary.
2. Protection against maloperations such as depressing the input key twice.
3. The STOP mode is automatically selected when the power supply switch is turned on and off.
4. Timer operation such as automatic recording in your absence.
5. Various controls other than the key operation.
 - Memory Counter
 - Auto play
 - External remote control jack (For RM-15).
6. IC, TC9121P
 1. Desired control is possible by lowering the input key temporarily to the "L" level.
 2. A number of output signal terminals are provided to apply to various type sets.
 3. The output terminal contains a bipolar transistor for easy driving of each circuit. It can also drive the LED for direct indicator.

Functions in Each Operation Mode

1. REC: This is valid only when the "L" level is set with the "PLAY" switch.
2. PAUSE: This is used to temporarily stop the tape running. It is a self-set/reset type switch and valid only during STOP, PLAY and REC modes.
3. AUTO PLAY: This operates when the "L" signal is applied to X or Z (ASO) during the REW operation.
 - H: The STOP mode is selected in this position.

L: The STOP mode is once selected, and then the PLAY mode is automatically selected.

4. X: This is an input terminal used to instruct STOP or PLAY operation during the REW mode. A memory counter is connected to this terminal.
(This terminal refuses any input during operation modes other than the REW modes.)
5. Z: This is an input terminal used to receive a signal which has detected stop of tape running.
The tape runs at "H" level.
The tape stops at "L" level.

Operation Timings of Output Terminals against Key Inputs

A stop period is provided between operation timings to protect a tape and the internal mechanism when the operation mode is directly changed over.

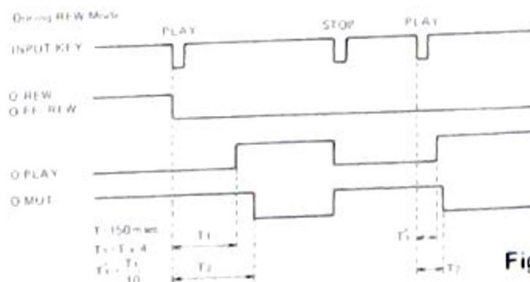

Figure 6.

The time constant is switched to speed up the operation response, except for the direct changeover function.

Functions at Turning ON and OFF the Power Supply

1. The STOP mode is automatically selected when the power switch is turned on and off. This function is realized by inserting a capacitor between the input terminal "STOP" and the ground.
2. Timer operation
A capacitor is inserted into each input terminal through the timer switch, so that the PLAY or REC/PLAY mode is automatically selected when the power is supplied. (This time constant is set longer than that of the STOP switch capacitor.)
3. Setting of the timer operation warm-up time and quick stop when the power is turned off.

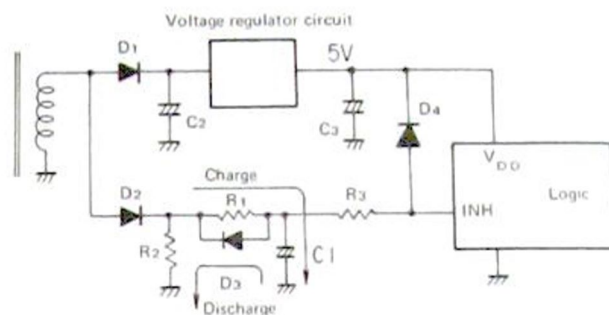

Figure 8.

< INH (Inhibit) Terminal >

When this terminal is set to the "L" position, all outputs other than O-MUT and O-TAPE-END are interrupted regardless of the operation mode. The output can be obtained only when this terminal is set to the "H" position. See Figure 8 and 9.

1. The warm-up time is determined by R1 and C1. INH threshold voltage is $V_{DD}/2$.
2. The discharge time constant is determined by C1 and R2. If the value of R2 is smaller, the time constant becomes shorter.
3. R3 and D4 are used to protect the IC.

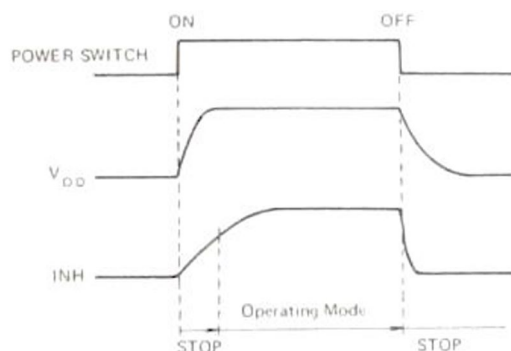

Figure 9.

Table 1

Pin No.	Terminal Name	Pin No.	Terminal Name	
1	GND	13	OSC	
2	(REW) IN	14	INH	OUT
3	(F.F.) IN	15	O-PLAY	OUT
4	(PLAY) IN	16	O-REC	OUT
5	(REC) IN	17	O-STOP	OUT
6	(STOP) IN	18	O-FF-RFW	OUT
7	(PAUSE) IN	19	O-PAUSE	OUT
8	A-REW IN	20	O-MUT	OUT
9	A-PLAY IN	21	O-REW	OUT
10	Y IN	22	O-FF	OUT
11	X IN	23	O-TAPE-END	OUT
12	Z IN	24	VDD	+B

Figure 7.

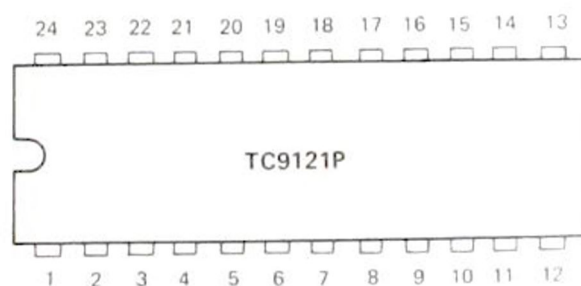

Figure 10.

Applying an input signal

1. (REW), (FF), (PLAY), (REC), (STOP), X, Y and Z terminals operate at the temporary "L" level. However, (REC) and (PLAY) must be simultaneously set to the "L" level.
2. Since (PAUSE) contains the chattering prevention circuit, it holds the 1.5 times duration of the oscillating cycle at "L" level.

Operation for multiple inputs

Input-1	Input-2 (multiple input performed together with the input-1)					Mode
(STOP)	(REW)	(FF)	(PLAY)	(REC)	(PAUSE)	STOP
(FF)	(REW)	(PLAY)				STOP
	(REC)	(PAUSE)				FF
(REW)	(FF)	(PLAY)				STOP
	(REC)	(PAUSE)				REW
(PLAY)	(PAUSE)				PLAY/PAUSE	
(REC)	(PLAY)					REC/PLAY
	(PAUSE)					PAUSE
	(PLAY) and (PAUSE)					REC/PAUSE

Figure 11.

Notes:

1. The (STOP) operation takes preference over all the other operations. No other input is accepted during input for the (STOP).
2. When two or more of (PLAY), (FF) and (REW) switches are depressed at the same time, the STOP mode is selected.
3. The (PAUSE) operation is permitted only during STOP, PLAY and REC/PLAY modes, and not permitted during FF and REW modes.
4. The (REC) input is valid only when it is given simultaneously with the (PLAY) input.

Operation Timing Chart

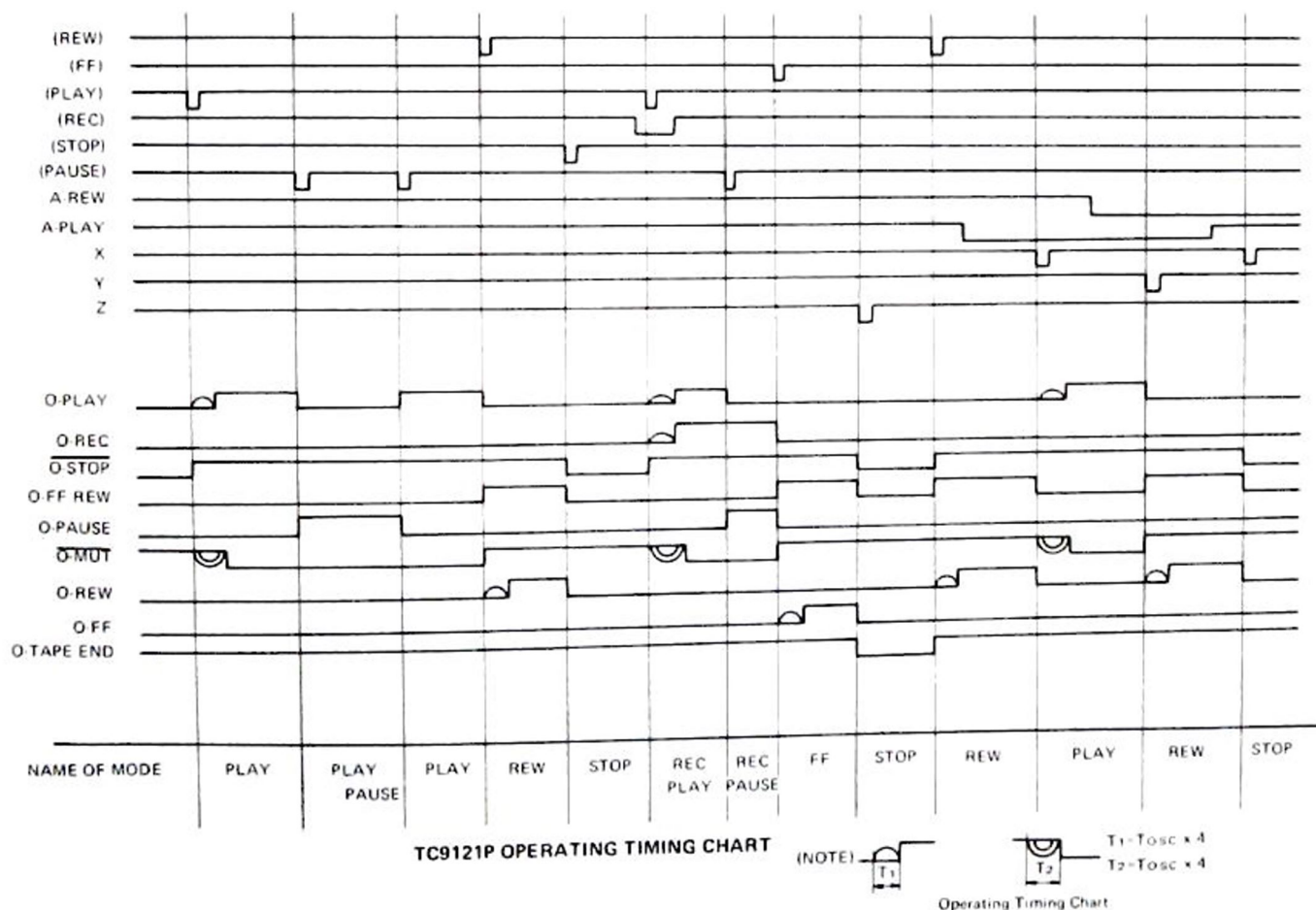

Figure 12.

LED METER CIRCUIT

1. Block diagram

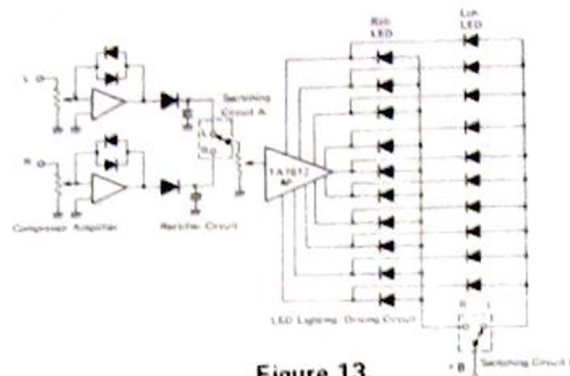

Figure 13.

2. Operation of the switching circuit

Supplies electricity alternately to L channel (Q1, Q3) and R channel (Q2, Q4) of the switching transistors provided before and after the LED and drive circuits, on half cycles of the multivibrator oscillation frequency (approx. 400Hz).

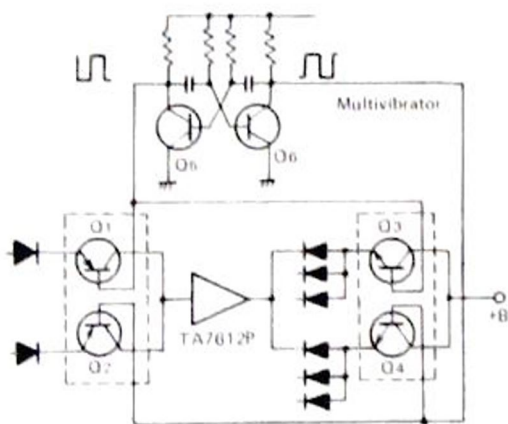

Figure 14.

3. TA7612AP

Ten comparators are built in so that the comparison reference voltage can be applied in series. These comparators turn on sequentially in relation to V_{in} .

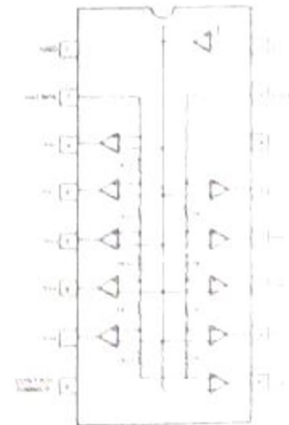

Figure 15.

MECHANICAL PERFORMANCE

- Tape Speed: 4.8 cm/sec.

No.	Item	Test Condition	Unit	Nominal	Limit
1	Tape speed deviation	Tape: MTT-111 (Play)	%	0	±2
2	Tape speed drift	Tape: MTT-111 (Play)	%	0.5	±1
3	Fast forwarding time	Tape: C-60, Tape torque: Less than 8 g.cm	Sec.	75	60 to 85
4	Rewinding time	Tape: C-60, Tape torque: Less than 8 g.cm	Sec.	75	60 to 85
5	Head Azimuth	MTT-114 (Play), Azimuth adjustment	dB	0	±2
6	Take-up torque	Play torque cassette tape	g.cm	50	35 to 65
		FF torque cassette tape	g.cm	110	80 to 130
		REW torque cassette tape	g.cm	110	80 to 130

Figure 16.

5. DISASSEMBLY INSTRUCTIONS

- Required tools for disassembly: Plus drivers (3mm and 2.6 mm).
- Parenthesized numerals for screws are the same symbol numbers as used on the exploded view.

REMOVAL OF FRONT PANEL

1. Remove two screws (1) holding the panel and the bottom plate as shown in Figure 17.
2. Remove two screws (2) holding the front panel and the front panel can be removed as shown in Figure 17.

REMOVAL OF REAR PANEL JACKS

1. Remove four screws (3) holding jack panel as shown in Figure 18.

REMOVAL OF SIDE PANEL ASSEMBLY

1. Remove four screws (4) holding the side panels as shown in Figure 19.
2. Remove two screws (5) holding the bottom plate and the side panels as shown in Figure 17.

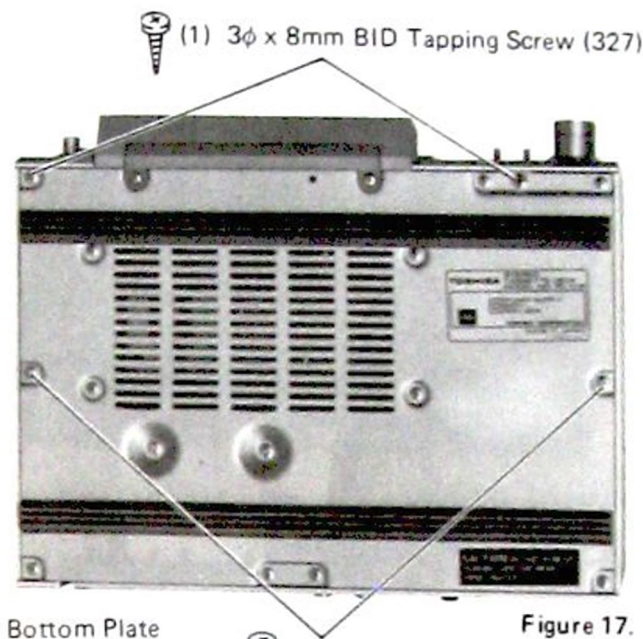

Bottom Plate

Figure 17.

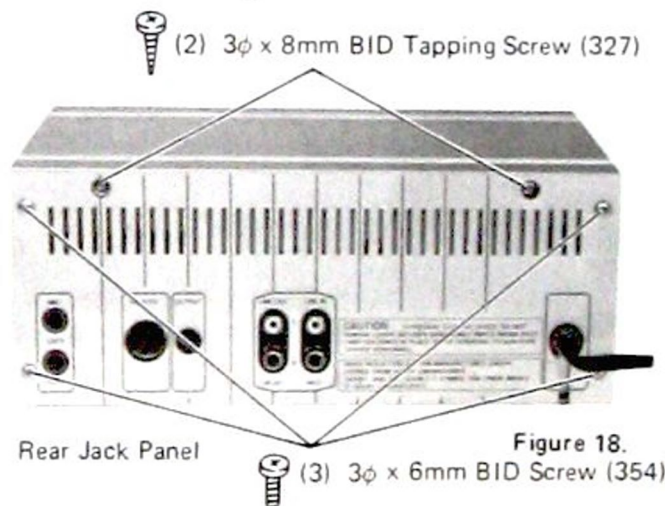

Rear Jack Panel

Figure 18.

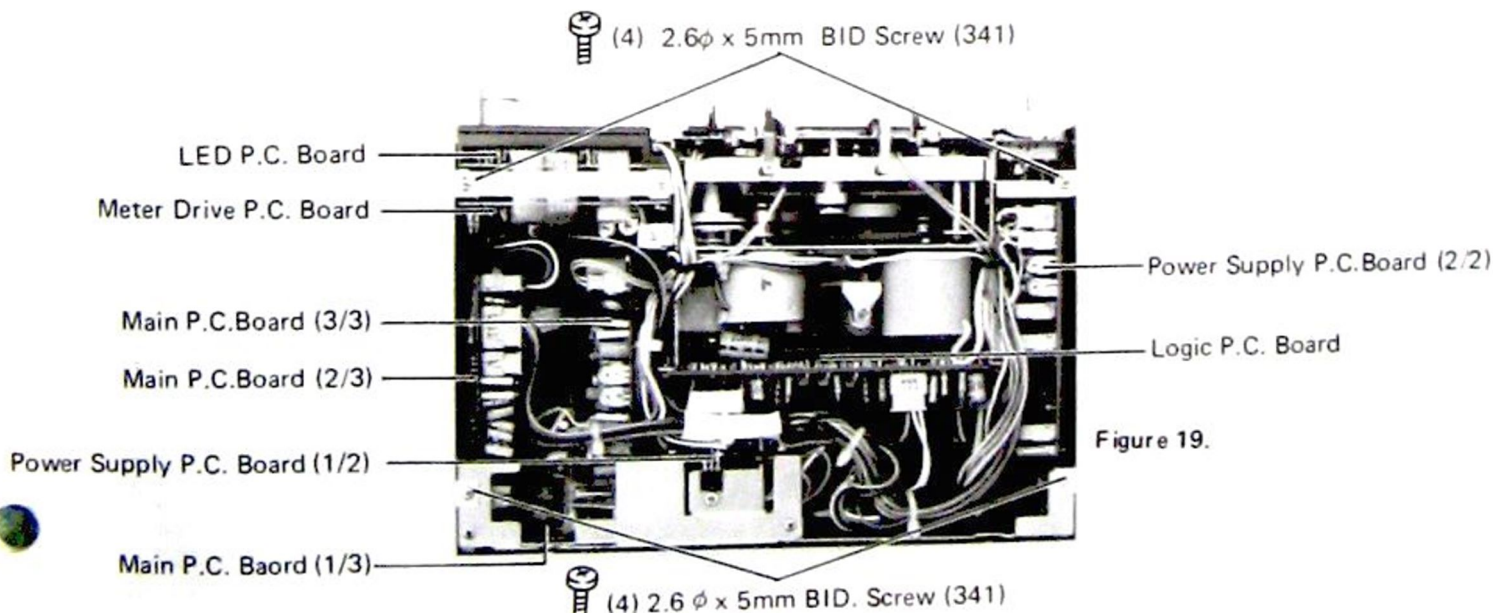

Figure 19.

- Locations of P.C. Boards are shown in above Figure 19.

REMOVAL OF HEAD COVER

1. Remove two screws (6) holding the head cover as shown in Figure 21.
2. Remove two screws (7) from the bottom plate, as shown in figure 20 and terminals of the recording playback and erase heads can be checked.

REMOVAL OF TIMER SWITCH

1. Remove two screws (8) holding the timer switch as shown in Figure 21.

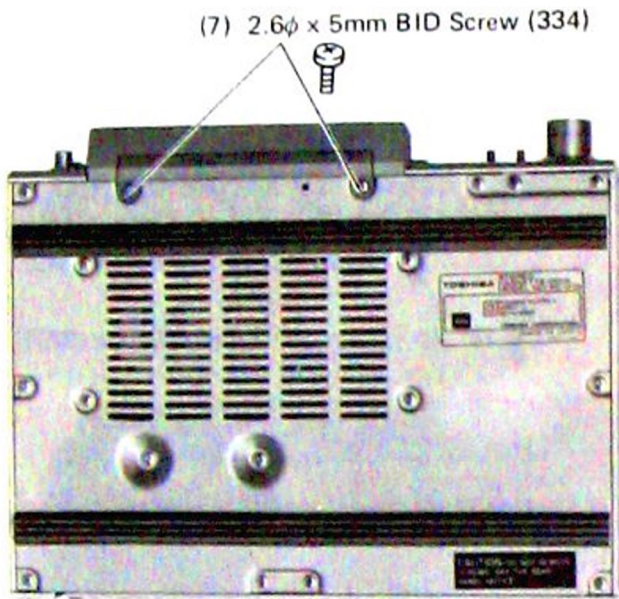

Figure 20.

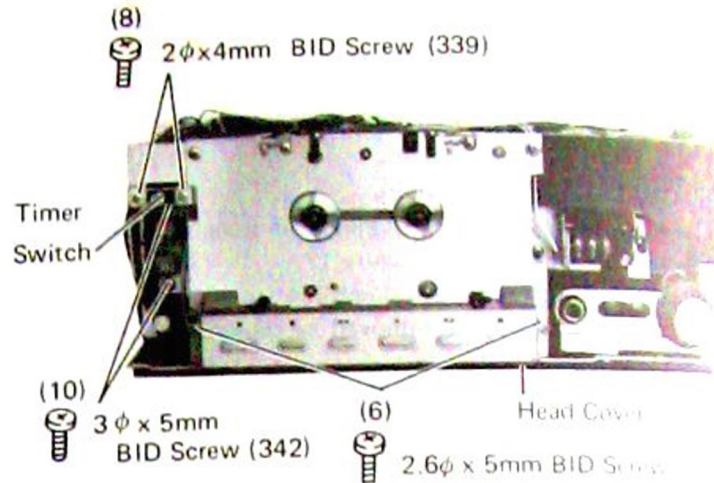

Figure 21

REMOVAL OF POWER SUPPLY P.C. BOARDS (1/2, 2/2)

1. Remove the side panel assembly.
2. Remove two screws (9) holding the mounting bracket for the power supply P.C. Board (1/2) and then lift up the P.C. Board upward as shown in Figure 22.
3. Remove two screws (10) and one screw (11) holding the power supply P.C. Board (2/2) as shown in Figure 21 and 23.

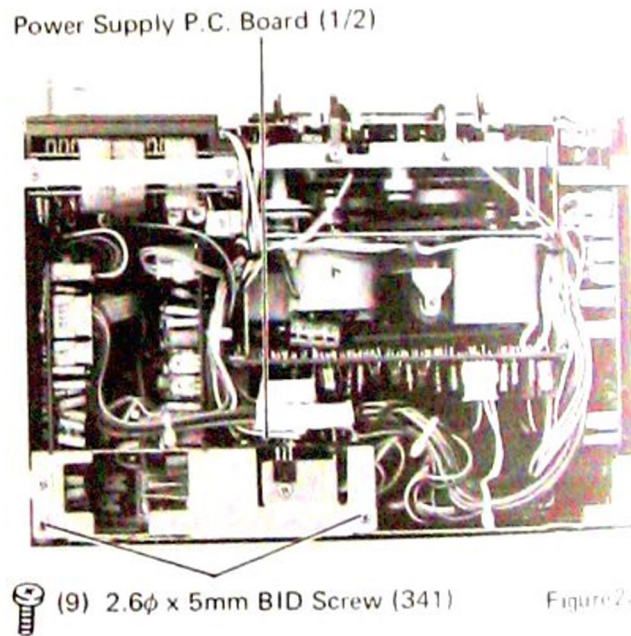

Figure 22

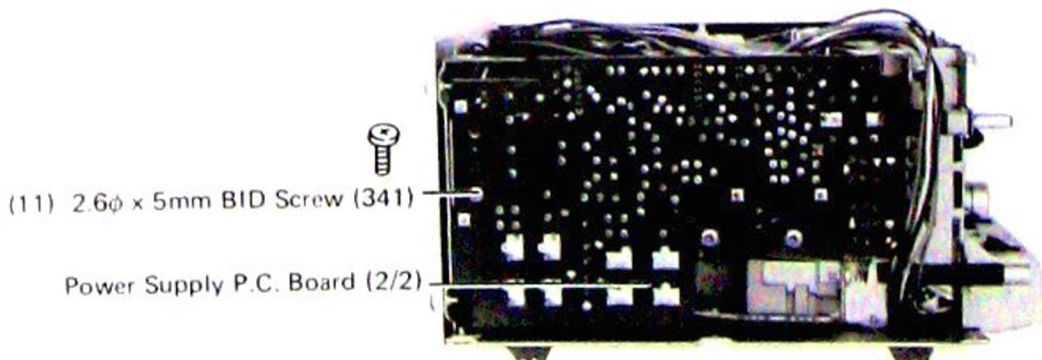

Figure 23.

REMOVAL OF POWER TRANSFORMER

1. Remove one screw (12) and four screws (13) and (14) holding the bracket for the transformer as shown in Figure 24 and 25 and the bracket can be removed.
2. Remove two screws (15) holding the power transformer with the mounting bracket as shown in Figure 25.

REMOVAL OF TERMINALS

1. After removal of the transformer mounting bracket, remove two black screws (16) holding the remote control socket as shown in Figure 25 and the socket can be removed.
2. Remove four plastic rivets (17) and one screw (18) holding the 4P jack and the 2P jack as shown in Figure 25 and then each jack can be removed. The 2P jack is soldered with the Main P.C. Board (1/3).

REMOVAL OF MAIN P.C. BOARD (1/3, 2/3, 1/3)

1. After removal of the power transformer mounting bracket, remove two screws (19) and one screw (20) as shown in Figure 24 and 26. The type mechanism assembly and the main chassis assembly can be separated as illustrated with a dotted line. (See Figure 26.) This is capable of checking and replacing parts on the Main P.C. Board and the logic P.C. Board.

Amp Chassis

2P Jack (J402)

(18) 3φ x 6mm PAN Screw (348)

REMOVAL OF LEVEL METER

1. Remove two screws (21) and (22) holding the LED P.C. Board and the meter drive P.C. Board as shown in Figure 26 and 27, and these P.C. Boards with the tape counter can be removed. Take care of the counter belt looped on the tape counter.
2. Next, remove two screws (23) as shown in Figure 27, and light emitting diodes can be replaced.

(21) 2.6φ x 5mm BID Screw (341)

(20) 2.6φ x 5mm BID Screw (341)

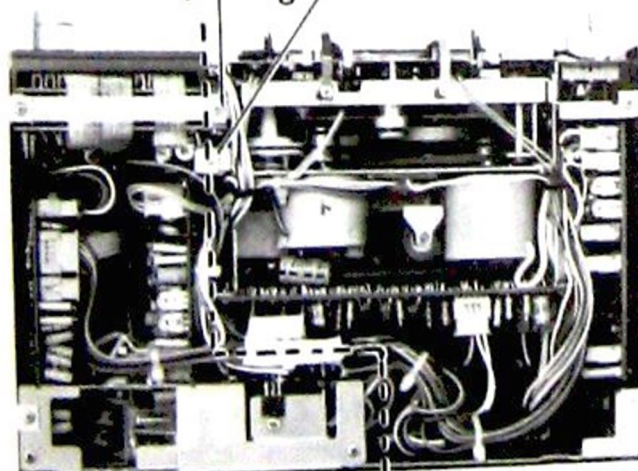

Figure 26.

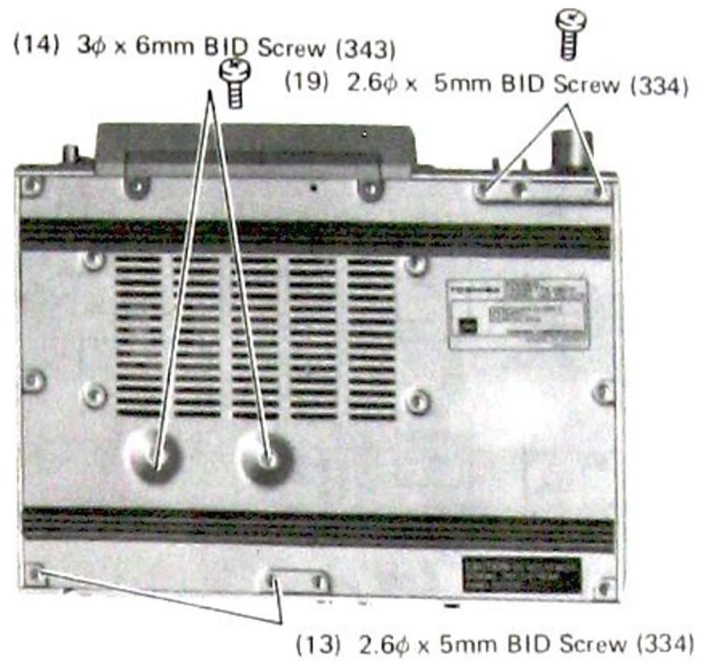

Figure 24.

Power Transformer Mounting Bracket

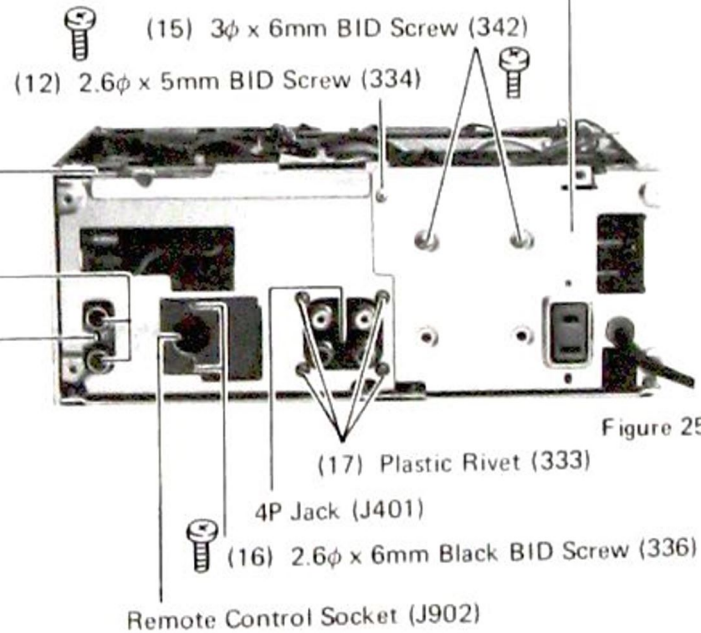
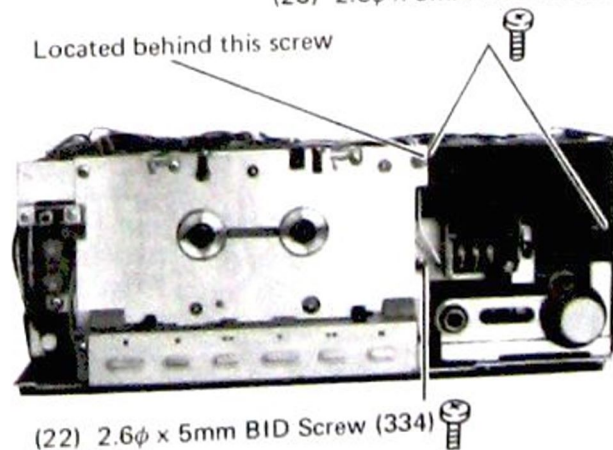

Figure 25.

Remote Control Socket (J902)

(23) 2.6φ x 5mm BID Screw (334)
Located behind this screw

(22) 2.6φ x 5mm BID Screw (334)

Figure 27.

6. BLOCK DIAGRAM

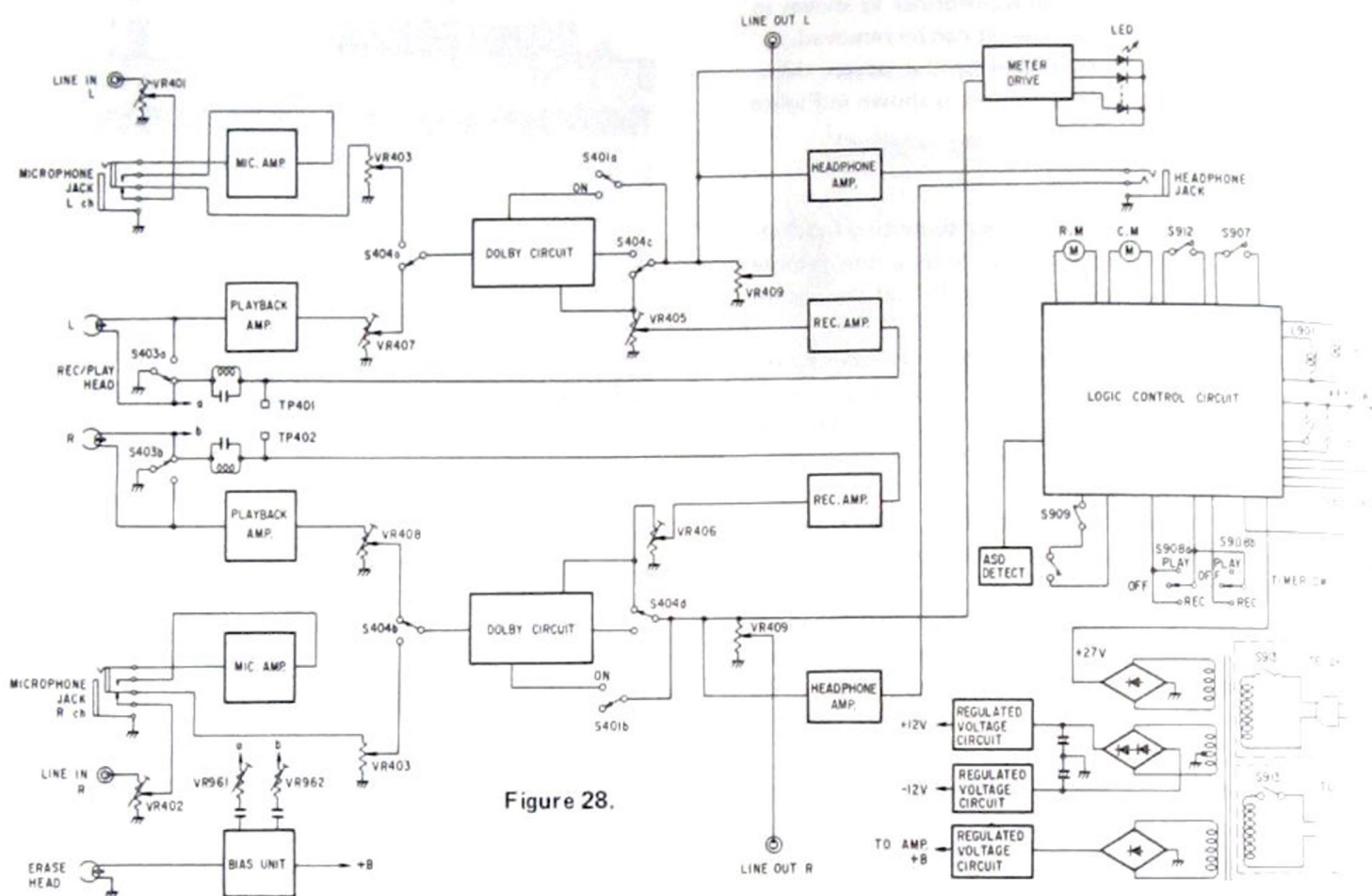

Figure 28.

TEST EQUIPMENTS

1. VTVM (Vacuum Tube Voltmeter)
2. Signal Generator
3. Resistance Attenuator
4. Screwdriver
5. Test Tapes
 - MTT-111 (3 kHz)
 - MTT-150 (400 Hz)
 - AC-511 (CHROME TAPE)

7. ELECTRICAL ADJUSTMENTS

Red Screen: Component side
 Black Screen: Solder side

Meter Drive P.C.Board

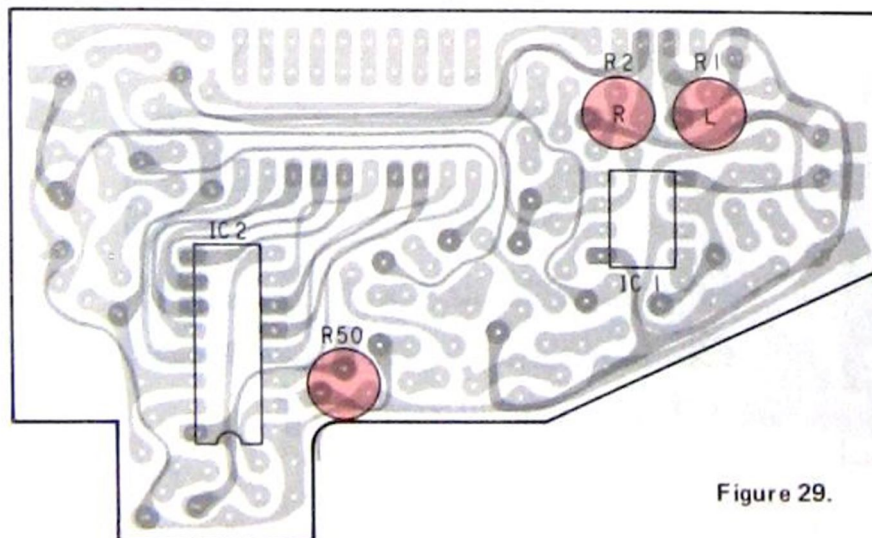

Power P.C.Board 2

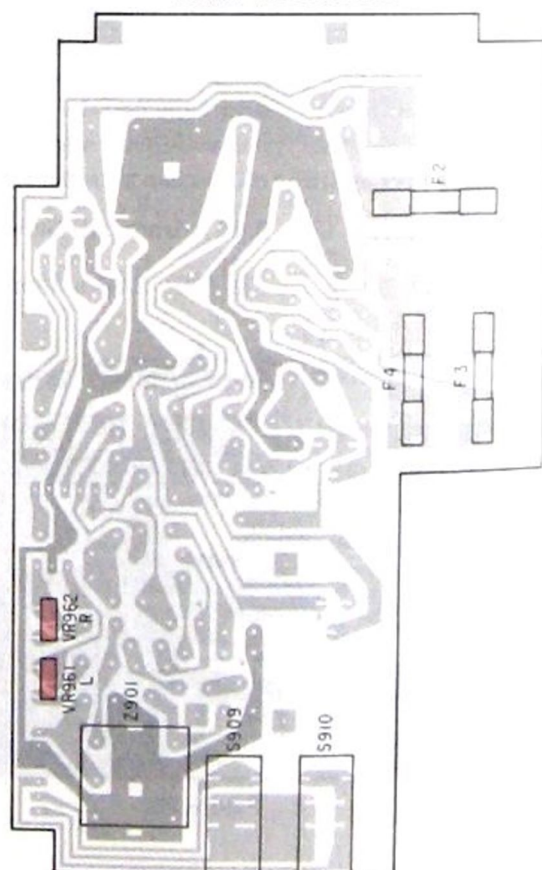

Figure 29.

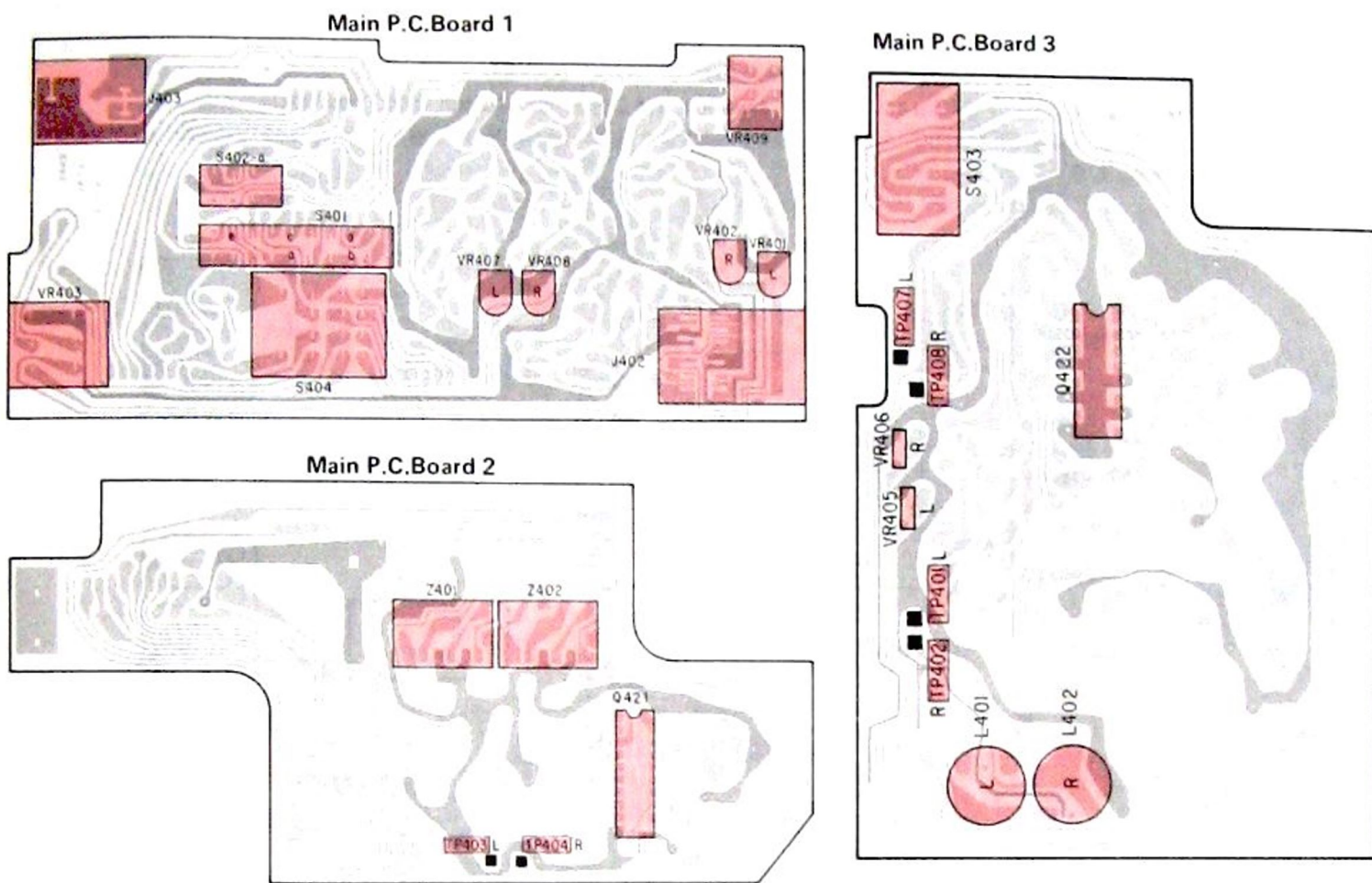

Figure 30.

RECORD/PLAYBACK HEAD AZIMUTH ADJUSTMENT

1. Connect a VTVM (or Oscilloscope) across the LINE OUT jacks (J401 c and d).
2. Set the Input Level to "MIN" position and Output Level to "MAX" position.
3. Playback the Test Tape (MTT-111, 3 kHz) and adjust the azimuth adjusting screw so that the VTVM indicates maximum position (or Oscilloscope indicates $0^{\circ} \pm 50^{\circ}$).

CAUTION: When L and R channels are measured at the same time, level difference should be kept under ± 2 dB at the maximum position.

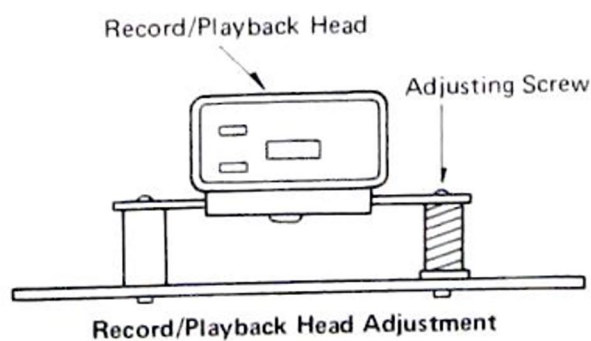

Figure 31.

PLAYBACK SENSITIVITY ADJUSTMENT

1. Connect a VTVM across the Test Points (TP403 and TP404.)
2. Set the Input Level to "MIN" position and Output Level to "MAX" position.
3. Set the Tape Selector Switch (S402) to "NORM" position and Dolby-NR Switch (S401) to "OUT" position.
4. Playback the Test Tape (MTT-150, 400 Hz) and adjust the Semi-fixed Resistors (VR407 and VR408) so that the VTVM indicates $775 \pm 10\text{mV}$.

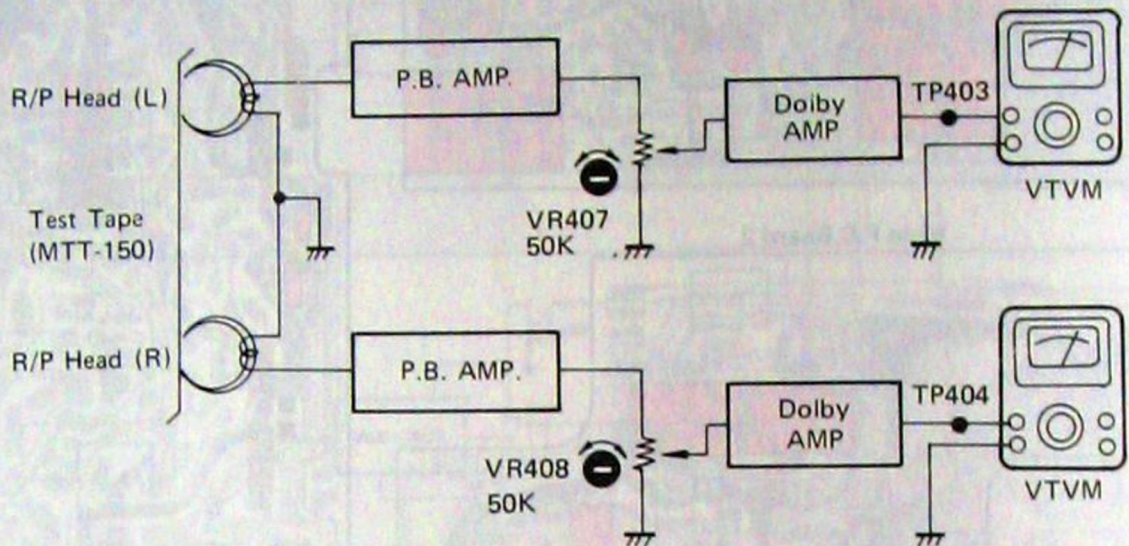

Figure 32.

BIAS LEAK ADJUSTMENT

1. Connect a VTVM across the Test Points (TP401 and TP402).
2. Set the Input Level to "MIN" position and Output Level to "MAX" position.
3. Set the Tape Selector Switch (S402) to "NORM" position and Dolby-NR Switch (S401) to "OUT" position.
4. Set this unit to recording mode and adjust the Trap Coils (L401 and L402) so that the VTVM indicates minimum position.

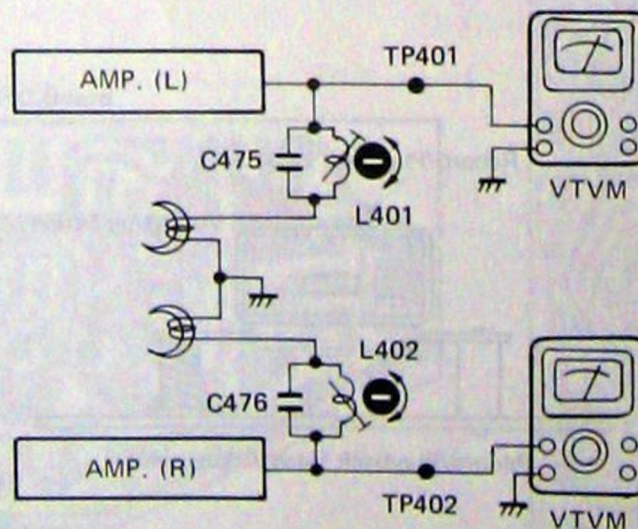

Figure 33.

RECORD/PLAYBACK FREQUENCY CHARACTERISTIC ADJUSTMENT

1. Connect a VTVM across the Test Points (TP403 and TP404).
2. Set the Input Level to "MAX" position and Output Level to "MAX" position.
3. Set the Tape Selector Switch (S402) to "CrO₂" position and Dolby-NR Switch (S401) to "OUT" position.
4. Apply a signal of 400 Hz/10 kHz, -43 dBV through the LINE IN jacks (J401 a and b).
5. Set the tape (AC-511) on this unit and record a signal of 400 Hz and 10 kHz. Then rewind and playback the tape and adjust the Semi-fixed Resistors (VR961 and VR962) so that the difference between 400 Hz and 10 kHz outputs is kept within 0 dB (± 1 dB).

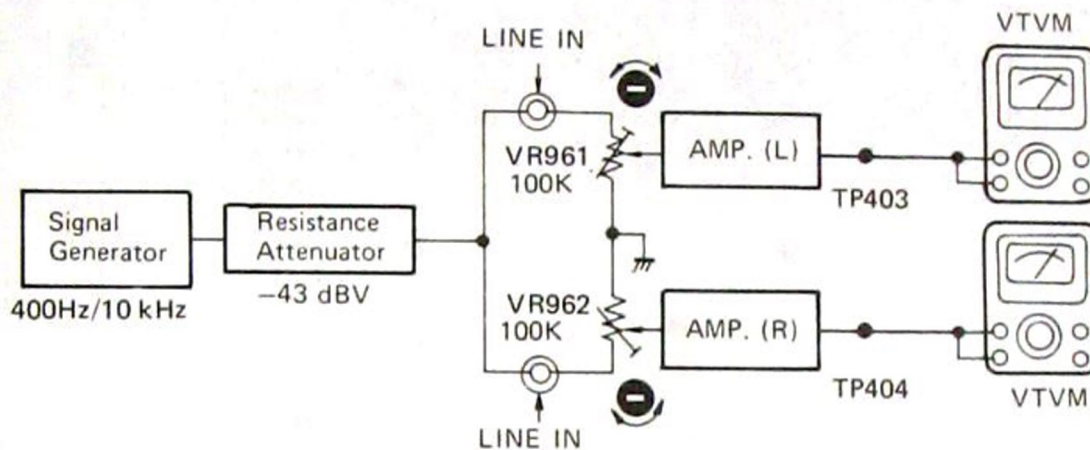

Figure 38.

RECORD/PLAYBACK SENSITIVITY ADJUSTMENT

1. Connect a VTVM across the Test Points (TP403 and TP404).
2. Set the Input Level to "MAX" position and Output Level to "MAX" position.
3. Set the Tape Selector Switch (S402) to "Cr-O₂" position and Dolby-NR Switch (S401) to "OUT" position.
4. Apply a signal of 400 Hz, -20 dBV through the LINE IN jacks (J401 a and b).
5. Set the tape (AC-511) on this unit and record a signal of 400 Hz. Then rewind and playback the recorded tape and adjust the Semi-fixed Resistors (VR405 and VR406) so that the VTVM indicates 775 ± 10 mV.

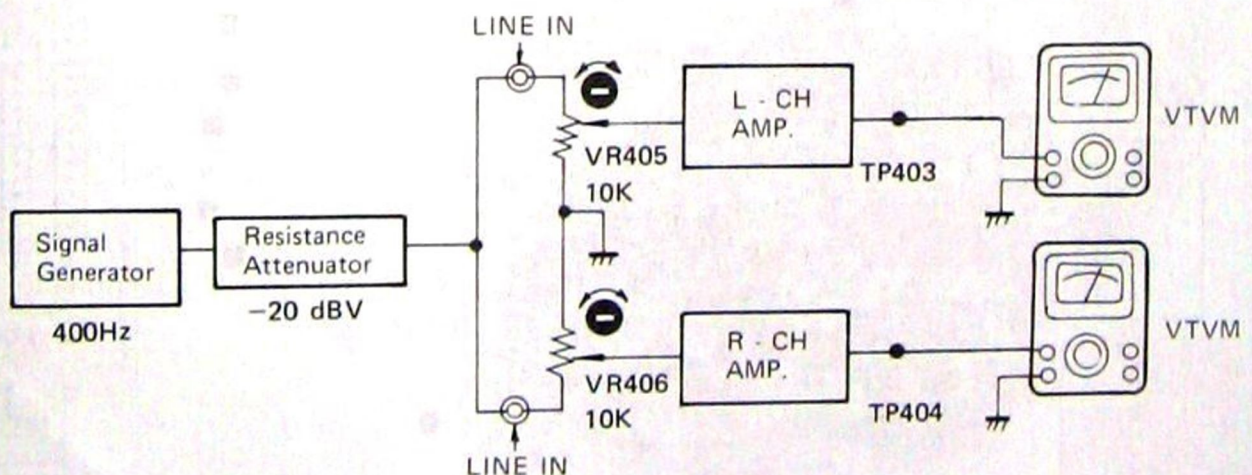

Figure 37.

CAUTION:

The Δ mark, the symbol No. circled w which have special characteristics important specified in the parts list.

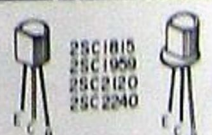
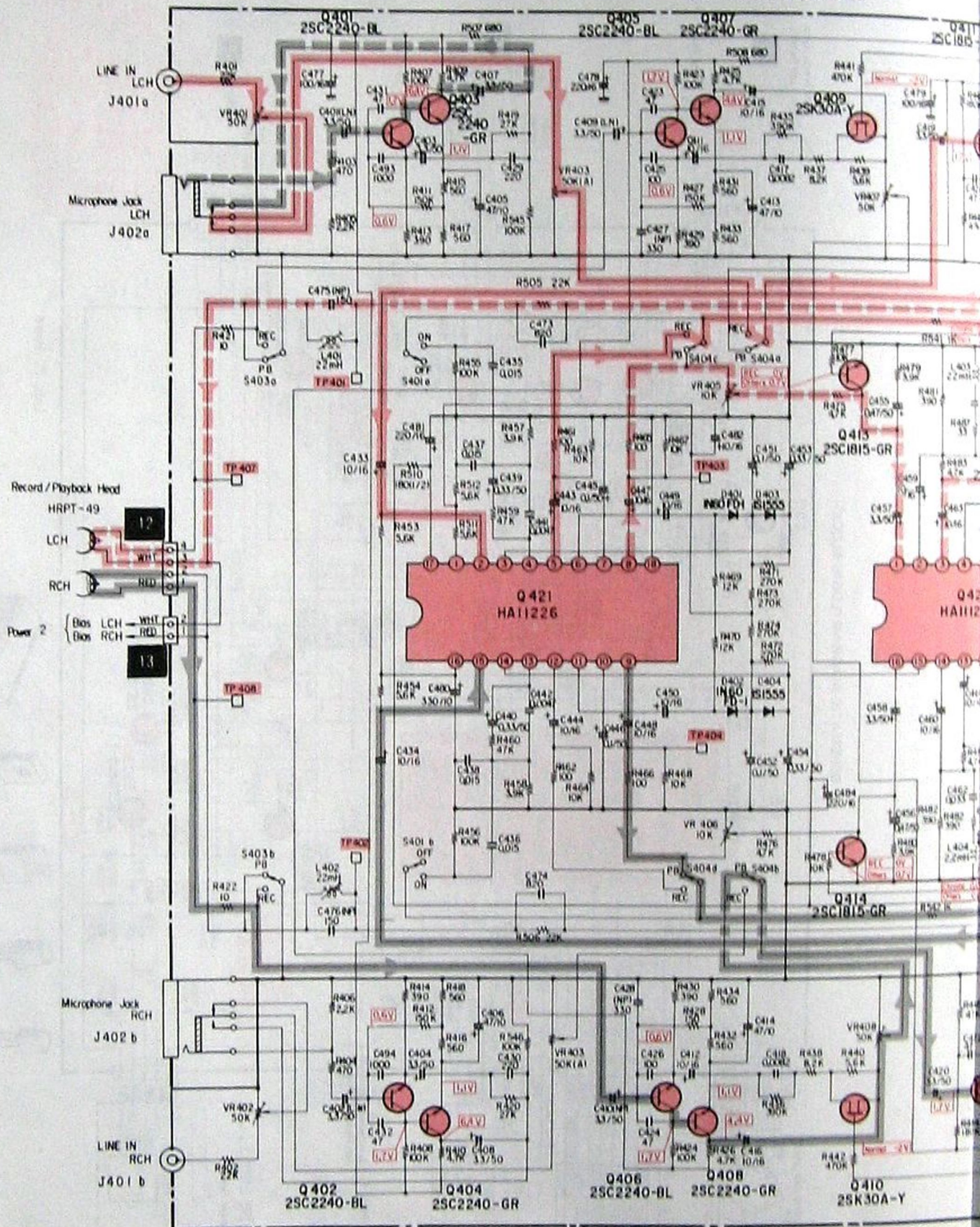
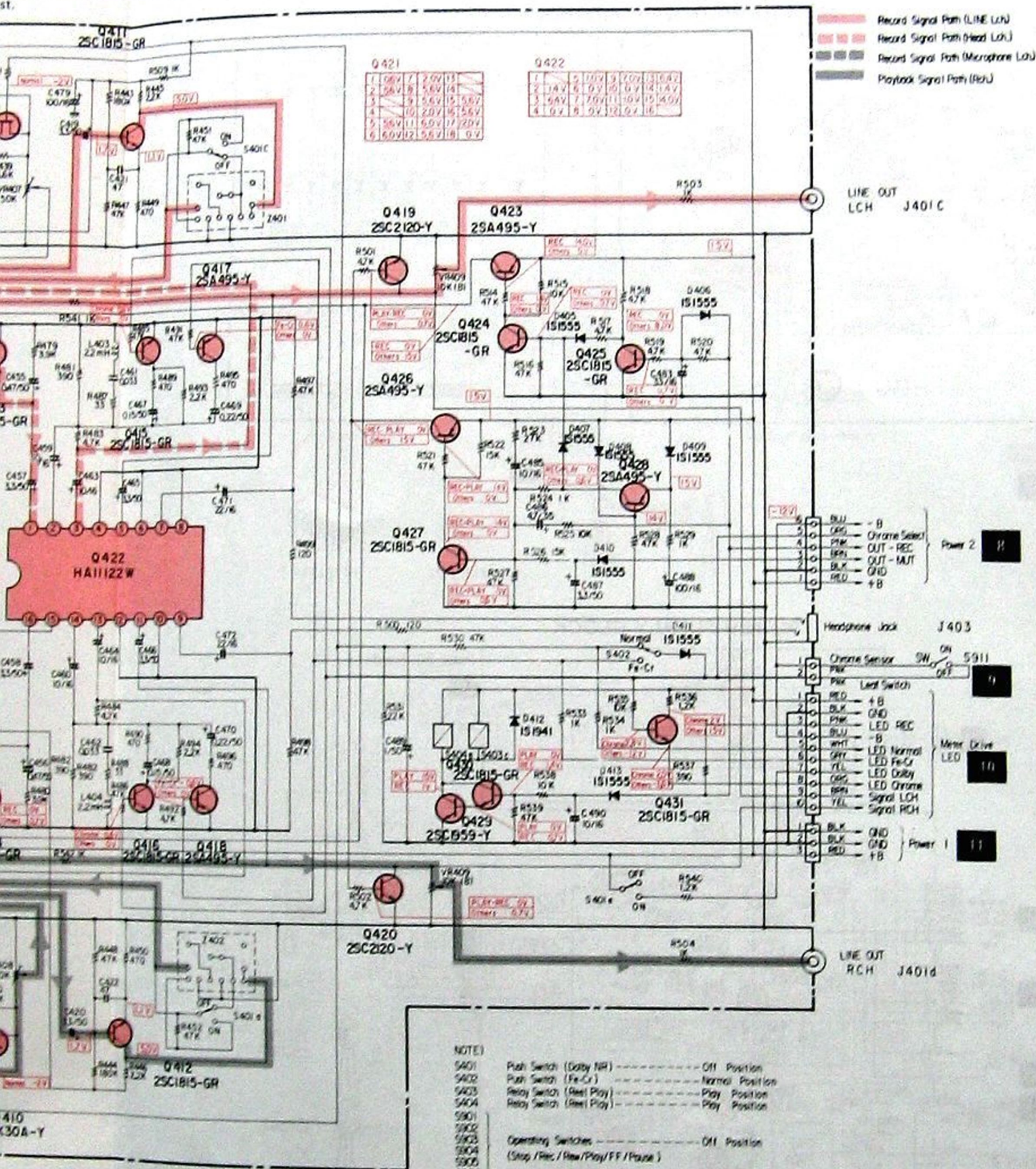

Figure 39.

9. SCHEMATIC DIAGRAM

Symbol No. circled with rectangle in the schematic diagram and the shaded area in the parts list designate components characteristics important for safety and should be replaced only with types identical to those in the original circuit or st.



NOTE)

- S401 Push Switch (Dolby NR) ----- Off Position
- S402 Push Switch (Fe-Cr) ----- Normal Position
- S403 Relay Switch (Reel Play) ----- Play Position
- S404 Relay Switch (Reel Play) ----- Play Position
- S901
- S902
- S903 Operating Switches ----- Off Position
- S904 (Stop / Rec / Rew / Play / FF / Pause)
- S905
- S906
- S907 Leaf Switch (Erase Prevention) ----- Off Position
- S908 Side Switch (Timer) ----- Off Position
- S909 Push Switch (Memory Counter) ----- Off Position
- S910 Push Switch (Auto Play) ----- Off Position
- S911 Leaf Switch (Chrome Sensor) ----- Off Position
- S912 Leaf Switch (Tape Detect) ----- Off Position
- S913 Push Switch (Power) ----- Off Position

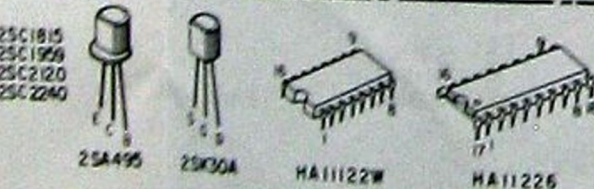

SCHEMATIC D

CAUTION:

The Δ mark, the symbol No. circled with rectangle in the schematic which have special characteristics important for safety and should be specified in the parts list.

METER DRIVE & LED BLOCK

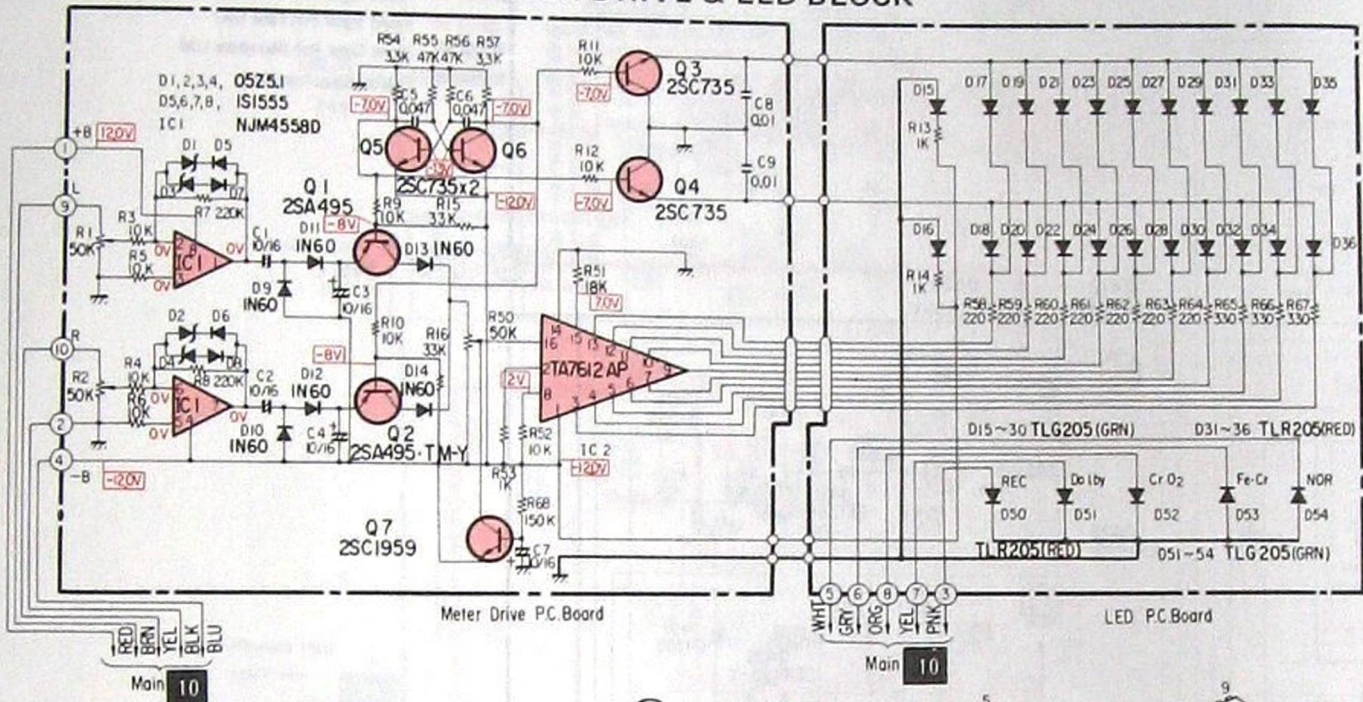

- 2SA495
- 2SC735
- 2SC1959
- NJM4558DA
- TA7612AP

POWER SUPPLY BLOCK

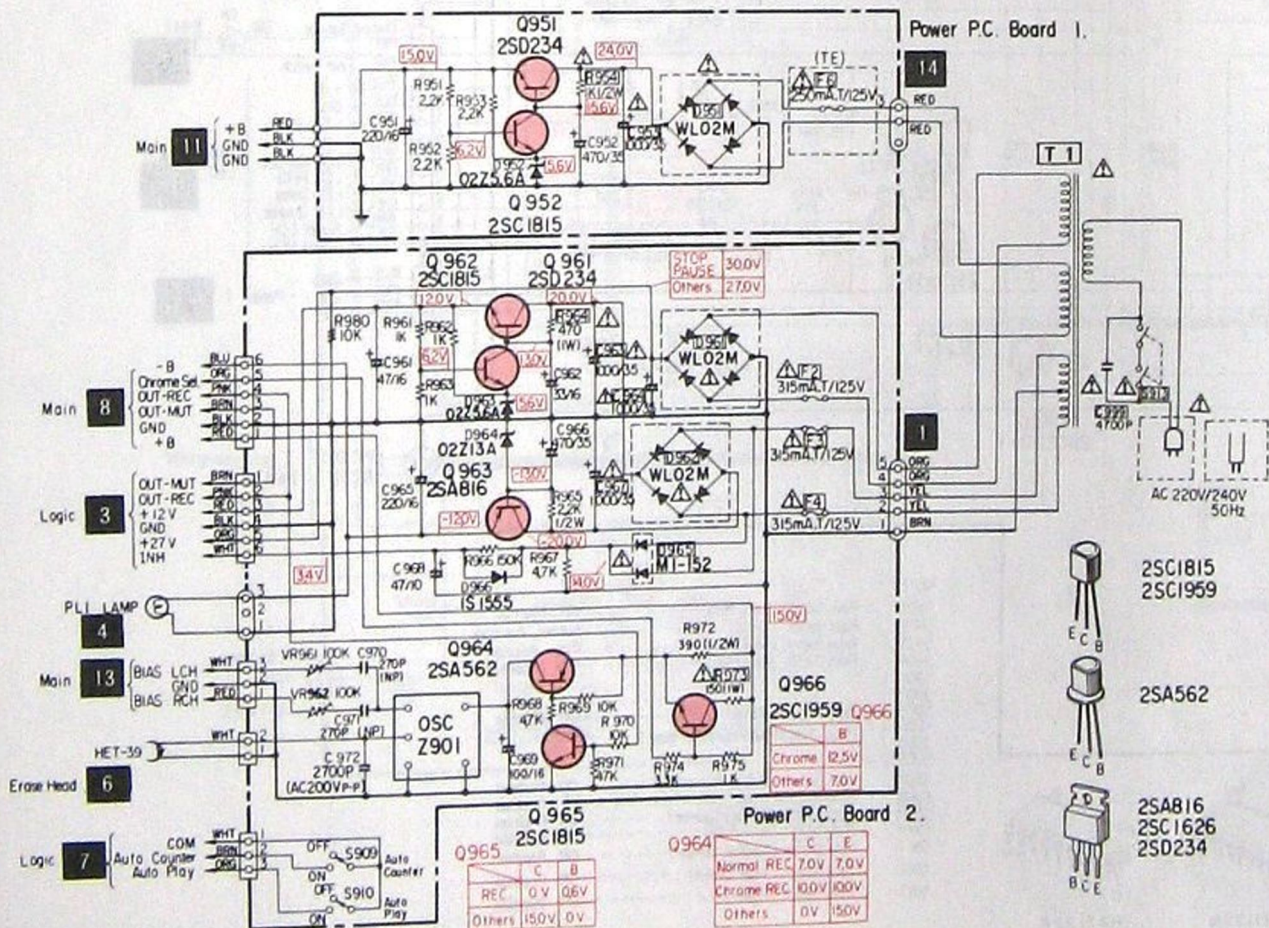

- 2SC1815
- 2SC1959
- 2SA562
- 2SA816
- 2SC1626
- 2SD234

Figure 4

■ SCHEMATIC DIAGRAM (LOGIC BLOCK)

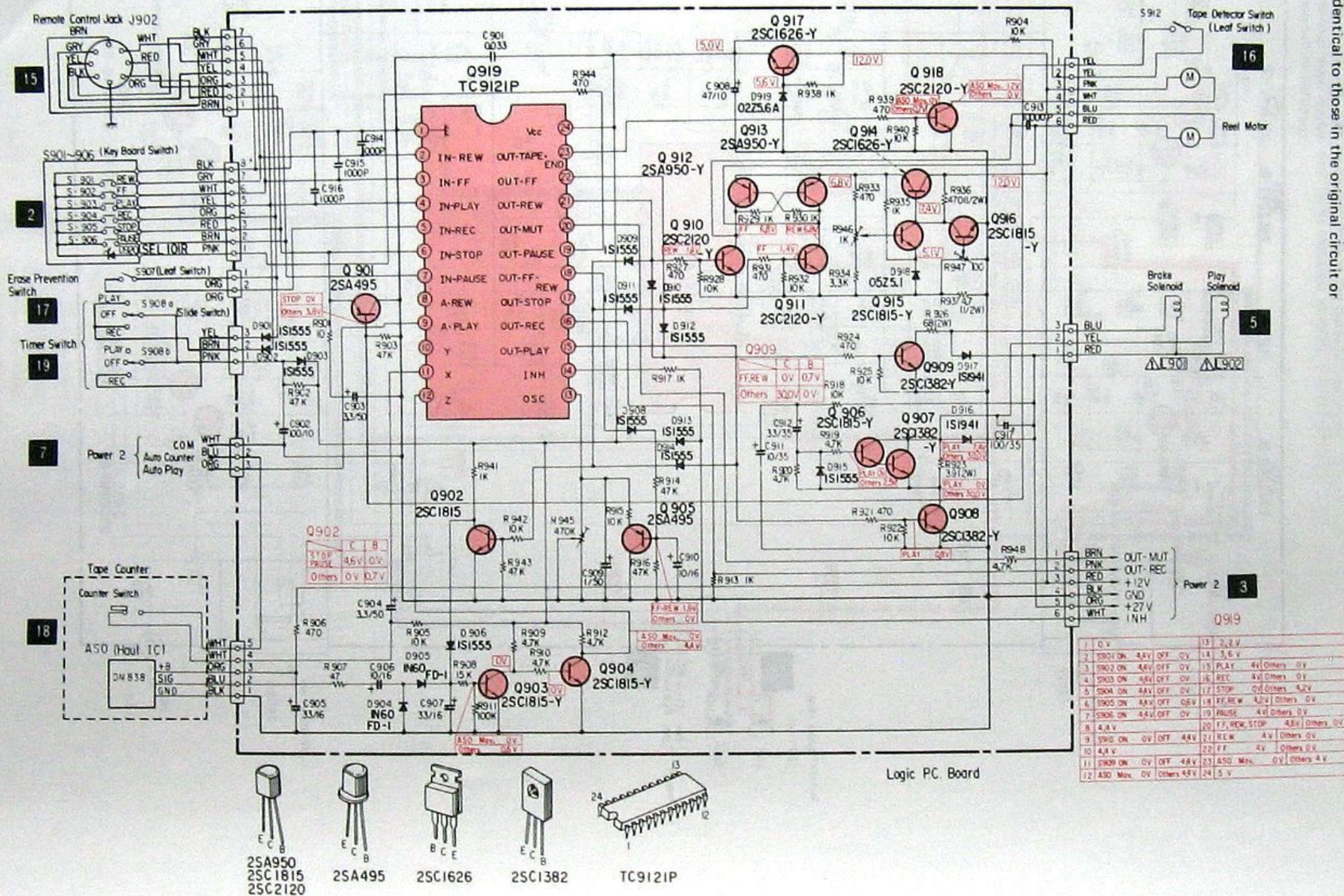

10. WIRING

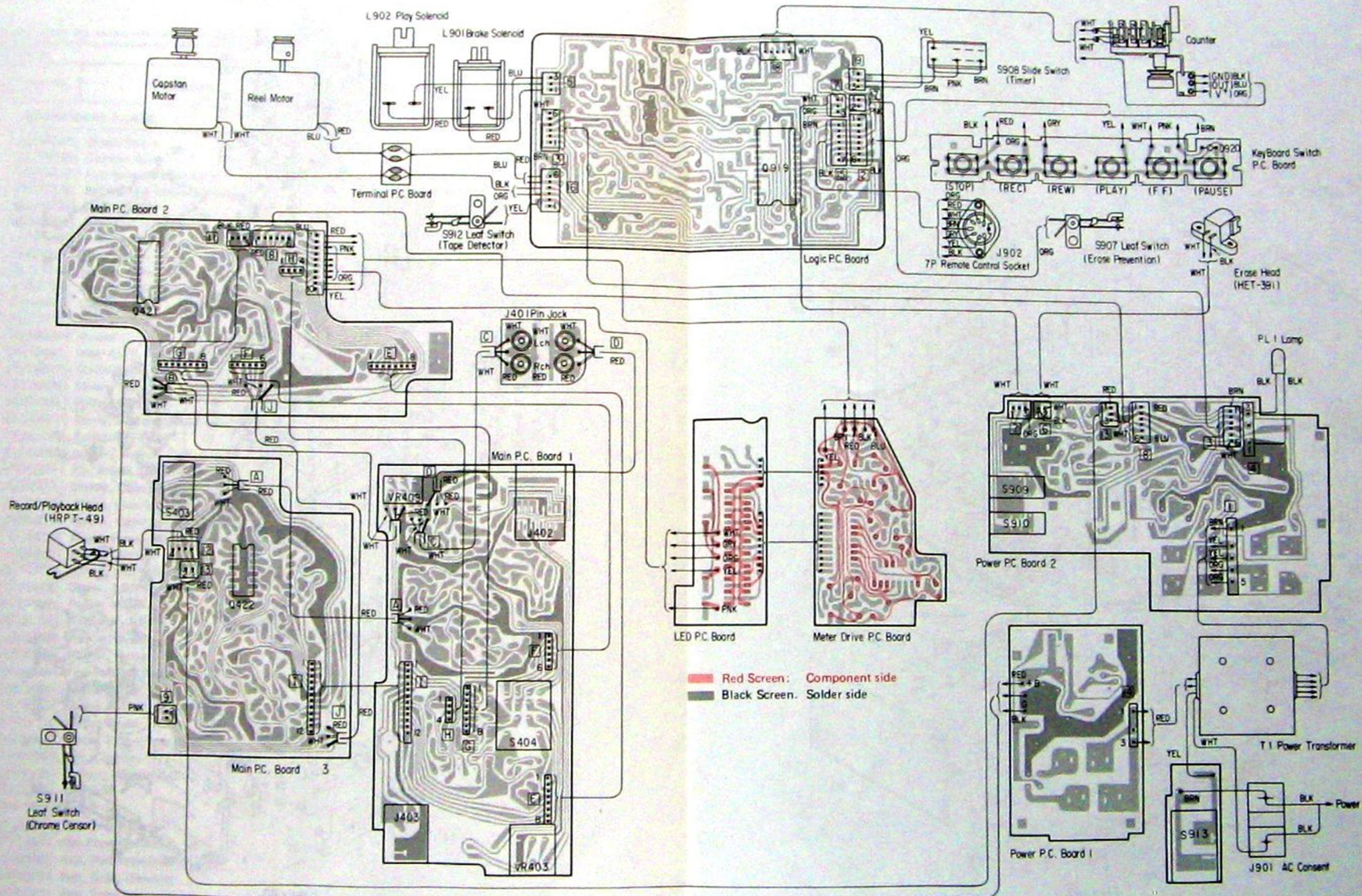

Figure 41

11. CABINET PARTS LOCATIONS

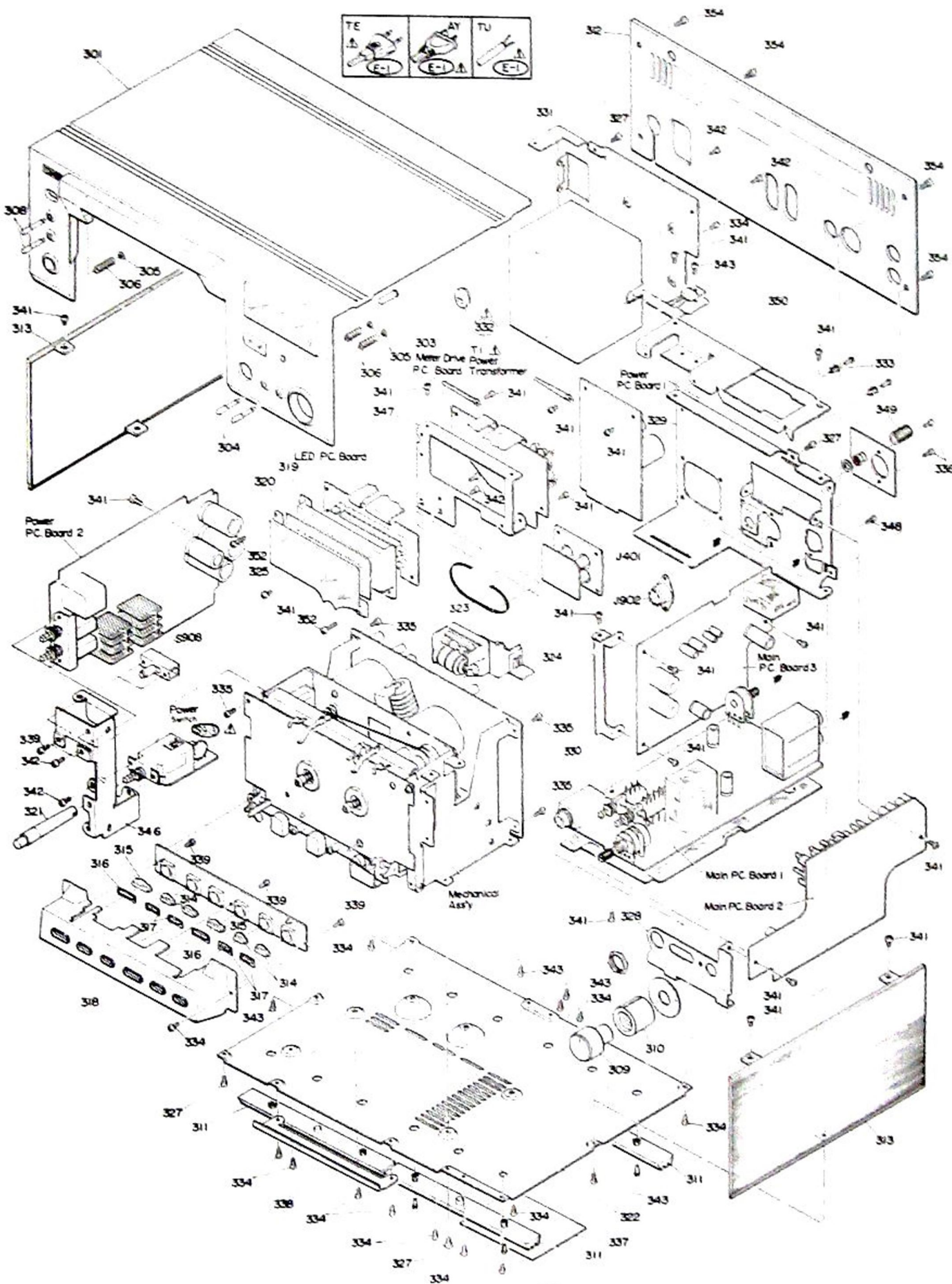

Figure 42.

NOTE: Parts excluded in the Parts List are not available as replacement parts.

12. MECHANICAL PARTS LOCATIONS

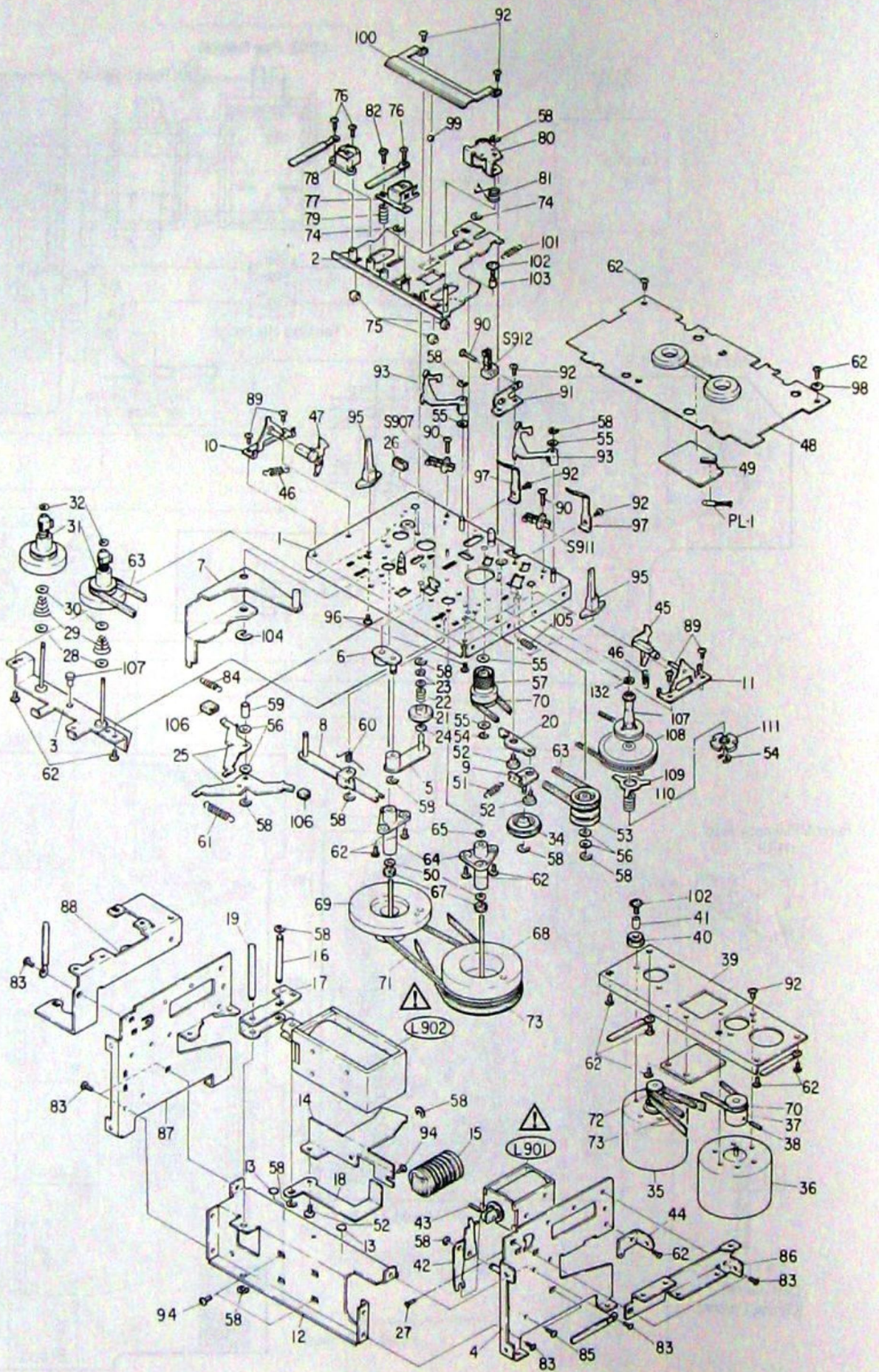

Figure 43.

NOTE: Parts excluded in the Parts List are not available as replacement parts.

13. PARTS LIST

CAUTION:

The Δ mark, the symbol No. circled with rectangle in the schematic diagram and the shaded area in the parts list designate components which have special characteristics important for safety and should be replaced only with types identical to those in the original circuit or specified in the parts list.

Symbol No.	Part No.	Description
MECHANICAL PARTS		
13	25764386	Sheet, Nylon
15	25719539	Damper Ass'y
21	25713372	Fast-forward Idler Ass'y
22	25772329	Spring, Fast-forward Idler
23	25764252	Nylon Washer
24	25762356	Felt, Fast-forward
26	25761400	Cushion, Arm
27	25858224	Cap, Rubber
28	25764246	Washer, Nylon
29	25772254	Spring, Back Tension
30	25764570	Washer
31	25712360	Reel Drum Ass'y
32	25764549	Washer
34	25713441	Idler Ass'y, Fast-forward
35	25719576	Motor Ass'y, Main
36	22125679	Motor, Reel
37	25751599	Pulley, Motor
38	22701431	Screw, 2.6 ϕ x 6mm (Slotted Set)
40	25761238	Cushion, Rubber
41	25733463	Spacer, Motor
43	25727251	Pin, Brake, Solenoid
45	25782257	Holder, Cassette (Right)
46	25771963	Spring, Cassette Holder
47	25782292	Holder, Cassette (Left)
48	25719577	Mechanism Cover Ass'y
50	25764592	Washer, Nylon
51	25771771	Spring, Fast-forward
52	22701472	Screw, 2.6 ϕ x 13mm (FLT)
53	25751482	Pulley, Middle
54	25735159	E Washer, 1.5 ϕ
55	25764398	Washer, Nylon
56	25764400	Washer, Nylon
57	25713478	Fast-forward Middle Pulley Ass'y
58	22703118	E Washer, 2 ϕ
60	25773374	Spring, Brake Lever
61	25771412	Spring, Brake
62	22707350	Screw, 2.6 ϕ x 5mm (DT BID)
63	25755389	Belt, Counter
64	25718158	Holder, Capstan Ass'y
65	25764396	Washer
67	25761291	Spacer
68	25717396	Flywheel Ass'y
69	25717397	Sub Flywheel Ass'y
70	25755376	Belt, Fast-forward/Rewind
71	25755379	Belt, Drive (Square)
72	25755377	Belt, Take up

Symbol No.	Part No.	Description
73	25755380	Belt, Drive (Flat)
74	22703279	E Washer, 3 ϕ
75	25753325	Roller
76	22707451	Screw, 2 ϕ x 5mm (BID)
77	22217306	Head, Record/Playback (HRPT-49)
78	22218206	Head, Erase (HET-39)
79	25772240	Spring, Head
80	25717422	Pinch Roller Ass'y
81	25773376	Spring, Pinch Roller
82	25723420	Screw, Head Adjustment
83	22707151	Screw, 2.6 ϕ x 5mm, (BID)
84	25771959	Spring, Play Lever
85	22701313	Screw, 3 ϕ x 4mm, (BID)
89	22707265	Screw, 2 ϕ x 4mm, (BID)
90	22701432	Screw, 2.6 ϕ x 8mm, (BID)
92	22701389	Screw, 2.6 ϕ x 3mm (BID)
94	22707452	Screw, 3 ϕ x 5mm, (BID)
95	25783205	Guide A
96	22707461	Screw, 2.6 ϕ x 6mm, (BID Tapping)
97	25774589	Spring, Cassette Holder
98	25735202	Washer
99	25757120	Steel Ball, 3 ϕ
100	25774390	Spring, Cassette Slider
101	25771689	Spring, Take up Lever
102	22707018	Screw
104	22703280	E Washer, 4 ϕ
105	25771898	Spring
106	25761354	Cushion, Arm
107	25713506	Pulley Ass'y, Tape-up
108	25758026	Pulley, Play
109	25734404	Control Plate, Torqu
110	25772531	Spring, Friction Plate
111	25758028	Spring, Retainer
112	25723427	Guide, FF Idler
CABINET PARTS		
301	25817440	Front Panel Ass'y
303	25837266	Knob, Counter Reset
304	25837228	Knob, Push (Long)
305	25674536	Washer, Nylon
306	25772471	Spring, Knob
308	25837237	Knob, Push (Short)
309	25837198	Knob, Volume (Small)
310	25837199	Knob, Volume (Large)
311	22874046	Leg, Bottom Plate

Symbol No.	Part No.	Description
312	25829372	Panel, Jack
313	25817394	Side Board Ass'y
314	25837201	Knob, Push (Short)
315	25837202	Knob, Push (Long)
316	25774596	Spring, Knob (Long)
317	25774598	Spring, Knob (Short)
318	25838099	Cover, Head
321	25816562	Knob Ass'y, Power
323	25755226	Belt, Counter
324	25873198	Counter
325	25838149	Indicator, Meter
327	22707327	Screw, 3 ϕ x 8mm, (BID Tapping), Chrome
332	25845528	Bush, Nylon
333	22705022	Rivet, Plastic, 3 ϕ x 5.5mm
334	22707363	Screw, 2.6 ϕ x 5mm, (DT BID), Chrome
335	22707170	Screw, 2.6 ϕ x 5mm, (TT BID)
336	22707037	Screw, 2.6 ϕ x 6mm, (BID), Black
338	25838109	Bracket, Head
339	22707265	Screw, 2 ϕ x 4mm, (BID)
341	22707151	Screw, 2.6 ϕ x 5mm, (BID)
342	22707452	Screw, 3 ϕ x 5mm, (BID)
343	22701321	Screw, 3 ϕ x 6mm, (BID), Black
344	22701361	Screw, 2.6 ϕ x 5mm, (FLT)
348	22701482	Screw, 3 ϕ x 6mm, (PAN)
349	22834944	Knob, Base
352	22707169	Screw, 2.6 ϕ x 10mm, (BID), Black
353	22707451	Screw, 2 ϕ x 5mm, (BID)
354	22701457	Screw, 3 ϕ x 6mm, (BID), Chrome
TRANSISTORS, DIODES AND IC'S		
Q1, 2	22114641	Transistor, 2SA495TM.NEW-Y
Q3, 4		Transistor, 2SC735-Y.X
Q5, 6		Transistor, 2SC735-Y.X
Q7		Transistor, 2SC1959NEW-Y
IC1		IC, RC4558-P
IC2		IC, TA7612P
Q401, 402		Transistor, 2SC2240NEW-BL
Q403, 404		Transistor, 2SC2240NEW-GR
Q405, 406		Transistor, 2SC2240NEW-BL
Q407, 408		Transistor, 2SC2240NEW-GR
Q409, 410	Transistor, 2SK30A-TM.Y	
Q411, 412	Transistor, 2SC1815NEW-GR	
Q413, 414	Transistor, 2SC1815NEW-GR	
Q415, 416	Transistor, 2SC1815NEW-GR	
Q417, 418	Transistor, 2SA495TM.NEW-Y	
C419, 420	Transistor, 2SC2120-Y	
Q421	22114624	IC, HA11226
Q422	22114684	IC, HA1122W
C423		Transistor, 2SA495TM.NEW-Y
Q424		Transistor, 2SC1815NEW-GR

Symbol No.	Part No.	Description
Q425		Transistor, 2SC1815NEW-GR
Q426		Transistor, 2SA495TM.NEW-Y
Q427		Transistor, 2SC1815NEW-GR
Q428		Transistor, 2SA495TM.NEW-Y
Q429		Transistor, 2SC1959NEW-Y
Q430		Transistor, 2SC1815NEW-GR
Q431		Transistor, 2SC1815NEW-GR
Q901		Transistor, 2SA495TM.NEW-Y
Q902		Transistor, 2SC1815-Y
Q903		Transistor, 2SC1815-Y
Q904		Transistor, 2SC1815-Y
Q905		Transistor, 2SA495TM.NEW-Y
Q906		Transistor, 2SC1815-Y
Q907		Transistor, 2SC1382-Y
Q908		Transistor, 2SC1382-Y
Q909		Transistor, 2SC1382-Y
Q910		Transistor, 2SC2120-Y
Q911		Transistor, 2SC2120-Y
Q912		Transistor, 2SA950-Y
Q913		Transistor, 2SA950-Y
Q914		Transistor, 2SC1626-Y
Q915		Transistor, 2SC1815-Y
Q916		Transistor, 2SC1815-Y
Q917		Transistor, 2SC1626-Y
Q918		Transistor, 2SC2120-Y
Q919		IC, TC9121P
Q951		Transistor, 2SD234-Y
Q952		Transistor, 2SC1815-Y
Q961		Transistor, 2SD234-Y
Q962		Transistor, 2SC1815-Y
Q963		Transistor, 2SA816-Y
Q964		Transistor, 2SA562-X.Y
Q965		Transistor, 2SC1815-Y
Q966		Transistor, 2SC1959NEW-Y
D1, 2		Diode, 05Z5.1
3, 4		
D5, 6		Diode, 1S1555V
7, 8		
D9, 10		Diode, 1N60-FD1
11, 12		
13, 14		
D15, 16		Diode, TLG205
17, 18		
19, 20		
21, 22		
23, 24		
25, 26		
27, 28		
29, 30		
D31, 32		Diode, TLR205
33, 34		
35, 36		
50		

Symbol No.	Part No.	Description
D51, 52 53, 54		Diode, TLG205
D401, 402		Diode, 1N60-FD1
D403, 404		Diode, 1S1555V
405, 406		
407, 408		
409, 410		
411, 413		
D412		Diode, 1S1941
D901, 902		Diode, 1S1555V
903, 906		
D904, 905		Diode, 1N60-FD1
D908, 909		Diode, 1S1555V
D910, 911		Diode, 1S1555V
912, 913		
914, 915		
D916, 917		Diode, 1S1941
D918		Diode, 05Z5.1
D919		Diode, 02Z5.6A
D920	22115616	Diode, SEL101R
D951	22115485	Diode, WL02M
D952		Diode, 02Z5.6A
D961, 962	22115485	Diode, WL02M
D963		Diode, 02Z5.6A
D964		Diode, 02Z13A
D965	22115427	Diode, MI-152
D966		Diode, 1S1555V

ELECTRICAL PARTS

T1	22223623	Transformer, Power (TE)
T1	22223625	Transformer, Power (TU, AY)
S401, 402	22195254	Push Switch, Fe-Cr/DOLBY NR
S403	22148645	Relay Switch
S404	22148653	Relay Switch
S901, 902	22195256	Key Board Switch
S903, 904		
S905, 906		
S907	22195199	Leaf Switch, Erase Prevention
S908	22195253	Slide Switch, TIMER
S909, 910	22195255	Push Switch, MEMORY COUNTER/AUTO PLAY
S911	22195199	Leaf Switch, Chrome Censure
S912	22195199	Leaf Switch, Tape Detector
S913	22146295	Push Switch, Power
Z401, 402	22153075	Filter, Dolby
Z901	22132524	Unit, BIAS OSC
J401	22163726	Jack, PIN
J402	22163675	Jack, Microphone
J403	22163676	Jack, Headphone
J902	22167456	Jack, Remote Control

Symbol No.	Part No.	Description
L401, 402	22232143	Coil, 22mH
L403, 404	22232207	Coil, 2.2mH
L901	22147209	Solenoid, Brake
L902	22147210	Solenoid, Play
PL1	22113441	Lamp, 40mA/14V
F2, 3, 4	22144407	Fuse, 315mA.T/125V
F6	22144289	Fuse, 250mA.T/125V (TE)
E1	22176286	Cord, Power (TE)
E1	22176536	Cord, Power (TU)
E1	22176588	Cord, Power (AY)

CAPACITORS

J = ±5%, K = ±10%, P = -0 +100%, Z = -20 + 80%

C1, 2	22445100	Electrolytic, 10mfd, 16V
C3, 4	22445100	Electrolytic, 10mfd, 16V
C5, 6	22371473	Mylar, 0.047mfd, 50V, J
C7	22445100	Electrolytic, 10mfd, 16V
C8, 9	22371103	Mylar, 0.01mfd, 50V, J
C401, 402	22468339	Electrolytic, 3.3mfd, 50V
C403, 404	22448339	Electrolytic, 3.3mfd, 50V
C405, 406	22443470	Electrolytic, 47mfd, 10V
C407, 408	22448339	Electrolytic, 3.3mfd, 50V
C409, 410	22468339	Electrolytic, 3.3mfd, 50V
C411, 412	22445100	Electrolytic, 10mfd, 16V
C413, 414	22443470	Electrolytic, 47mfd, 10V
C415, 416	22445100	Electrolytic, 10mfd, 16V
C417, 418	22371822	Mylar, 8200pF, 50V, J
C419, 420	22448339	Electrolytic, 3.3mfd, 50V
C421, 422	22362470	Ceramic, 47mfd, 50V, K
C423, 424	22362470	Ceramic, 47mfd, 50V, K
C425, 426	22362101	Ceramic, 100mfd, 50V, K
C427, 428	22321049	Polypropylene, 330mfd, 50V
C429	22362221	Ceramic, 220pF, 50V, K
C430	22349221	Ceramic, 220pF, 50V, K
C431, 432	22362470	Ceramic, 47mfd, 50V, K
C433, 434	22445100	Electrolytic, 10mfd, 16V
C435, 436	22371153	Mylar, 0.015mfd, 50V, J
C437, 438	22371153	Mylar, 0.015mfd, 50V, J
C439, 440	22440285	Electrolytic, 0.33mfd, 50V
C441, 442	22371472	Mylar, 4700pF, 50V, J
C443, 444	22445100	Electrolytic, 10mfd, 16V
C445, 446	22440283	Electrolytic, 0.1mfd, 50V
C447, 448	22445100	Electrolytic, 10mfd, 16V
C449, 450	22445100	Electrolytic, 10mfd, 16V
C451, 452	22440283	Electrolytic, 0.1mfd, 50V
C453, 454	22440285	Electrolytic, 0.33mfd, 50V
C455, 456	22440286	Electrolytic, 0.47mfd, 50V
C457, 458	22448339	Electrolytic, 3.3mfd, 50V
C459, 460	22445100	Electrolytic, 10mfd, 16V
C461, 462	22371333	Mylar, 0.033mfd, 50V, J
C463, 464	22445100	Electrolytic, 10mfd, 16V

Symbol No.	Part No.	Description
C465, 466	22448339	Electrolytic, 3.3mfd, 50V
C467, 468	22480004	Electrolytic, 0.15mfd, 50V
C469, 470	22440284	Electrolytic, 0.15mfd, 50V
C471, 472	22445220	Electrolytic, 22mfd, 16V
C473, 474	22349821	Ceramic, 820pF, 50V, K
C475, 476	22321083	Ceramic, 150mfd, 50V, J
C477	22445101	Electrolytic, 100mfd, 16V
C478	22445221	Electrolytic, 220mfd, 16V
C479	22445101	Electrolytic, 100mfd, 16V
C480	22443331	Electrolytic, 330mfd, 10V
C481	22445221	Electrolytic, 220mfd, 16V
C482	22445100	Electrolytic, 10mfd, 16V
C483	22445330	Electrolytic, 33mfd, 16V
C484	22445221	Electrolytic, 220mfd, 16V
C485	22445100	Electrolytic, 10mfd, 16V
C486	22447479	Electrolytic, 4.7mfd, 35V
C487	22448339	Electrolytic, 3.3mfd, 50V
C488	22445101	Electrolytic, 100mfd, 16V
C489	22448109	Electrolytic, 1mfd, 50V
C490	22445100	Electrolytic, 10mfd, 16V
C493, 494	22349102	Ceramic, 1000pF, 50V, K
C901	22372333	Mylar, 0.033mfd, 50V, K
C902	22443101	Electrolytic, 100mfd, 10V
C903	22448339	Electrolytic, 3.3mfd, 50V
C904	22448339	Electrolytic, 3.3mfd, 50V
C905	22445330	Electrolytic, 33mfd, 16V
C906	22445100	Electrolytic, 10mfd, 16V
C907	22445330	Electrolytic, 33mfd, 16V
C908	22443470	Electrolytic, 47mfd, 10V
C909	22448109	Electrolytic, 1mfd, 50V
C910	22445100	Electrolytic, 10mfd, 16V
C911	22447100	Electrolytic, 10mfd, 35V
C912	22447330	Electrolytic, 33mfd, 35V
C913	22349103	Ceramic, 0.01mfd, 50V, K
C914	22349102	Ceramic, 1000pF, 50V, K
C915	22349102	Ceramic, 1000pF, 50V, K
C916	22349102	Ceramic, 1000pF, 50V, K
C917	22447101	Electrolytic, 100mfd, 35V
C951	22445221	Electrolytic, 220mfd, 16V
C952	22487471	Electrolytic, 470mfd, 35V
△ C953	22487102	Electrolytic, 1000mfd, 35V
C961	22445101	Electrolytic, 100mfd, 16V
C962	22445330	Electrolytic, 33mfd, 16V
△ C963	22487102	Electrolytic, 1000mfd, 35V
△ C964	22487102	Electrolytic, 1000mfd, 35V
C965	22445221	Electrolytic, 220mfd, 16V
C966	22487471	Electrolytic, 470mfd, 35V
△ C967	22487102	Electrolytic, 1000mfd, 35V
C968	22443470	Electrolytic, 47mfd, 10V
C969	22445101	Electrolytic, 100mfd, 16V
C970, 971	22321048	Polypropylene, 270pF, 50V, J
C972	22380099	Polyethylene Film, 2700pF, 200V, K

Symbol No.	Part No.	Description
C999	22340090	Ceramic, 4700pF, 250V, Z
RESISTORS		
All resistors are $\pm 5\%$, $\frac{1}{4}W$, carbon film unless otherwise noted. K = $\pm 10\%$		
R1, 2	22648185	Semi-fixed Resistor, 50k ohm
R3, 4	22555103	10k ohm
R5, 6	22555103	10k ohm
R7, 8	22555224	220k ohm
R9, 10	22555103	10k ohm
R11, 12	22555103	10k ohm
R13, 14	22561102	Solid, 1k ohm, $\frac{1}{4}W$, K
R15, 16	22545333	33k ohm
R50	22658185	Semi-fixed Resistor, 50k ohm
R51	22555183	18k ohm
R52	22555103	10k ohm
R53	22555102	1k ohm
R54, 57	22555332	3.3k ohm
R55, 56	22555473	47k ohm
R58, 59	22561221	Solid, 220 ohm, $\frac{1}{4}W$, K
60, 61		
62, 63		
64		
R65, 66	22561331	Solid, 330 ohm, $\frac{1}{4}W$, K
67		
R68	22555154	150k ohm
R401, 402	22555223	22k ohm
R403, 404	22555471	470 ohm
R405, 406	22555222	2.2k ohm
R407, 408	22555104	100k ohm
R409, 410	22555472	4.7k ohm
R411, 412	22555154	150k ohm
R413, 414	22555391	390 ohm
R415, 416	22555562	560 ohm
R417, 418	22555562	560 ohm
R419, 420	22555273	27k ohm
R421, 422	22545100	10 ohm
R423, 424	22555104	100k ohm
R425, 426	22555472	4.7k ohm
R427, 428	22555154	150k ohm
R429, 430	22555391	390 ohm
R431, 432	22555561	560 ohm
R433, 434	22555561	560 ohm
R435, 436	22555394	390k ohm
R437, 438	22555822	8.2k ohm
R439, 440	22555562	5.6k ohm
R441, 442	22555474	470k ohm
R443, 444	22555184	180k ohm
R445, 446	22555222	2.2k ohm
R447, 448	22555473	47k ohm
R449, 450	22555470	470 ohm
R451, 452	22555473	47k ohm

Symbol No.	Part No.	Description
R453, 454	22555562	5.6k ohm
R455, 456	22555104	100k ohm
R457, 458	22555392	3.9k ohm
R459, 460	22555473	47k ohm
R461, 462	22555101	100 ohm
R463, 464	22555103	10k ohm
R465, 466	22555101	100 ohm
R467, 468	22555103	10k ohm
R469, 470	22555123	12k ohm
R471, 472	22555274	270k ohm
R473, 474	22555274	270k ohm
R475, 476	22555472	4.7k ohm
R477, 478	22555103	10k ohm
R479, 480	22555392	3.9k ohm
R481, 482	22555391	390 ohm
R483, 484	22555472	4.7k ohm
R485	22555473	47k ohm
R486	22545473	47k ohm
R487, 488	22555560	56 ohm
R489, 490	22555471	470 ohm
R491	22555473	47k ohm
R492	22545473	47k ohm
R493, 494	22555222	2.2k ohm
R495, 496	22555471	470 ohm
R497, 498	22555473	47k ohm
R499, 500	22555121	120 ohm
R501, 502	22555472	4.7k ohm
R503, 504	22555102	1k ohm
R505, 506	22555223	22k ohm
R507	22555681	680 ohm
R508	22555681	680 ohm
R509	22555102	1k ohm
R511	22545562	5.6k ohm
R512	22555562	5.6k ohm
R514	22555473	47k ohm
R515	22555103	10k ohm
R516	22555473	47k ohm
R517	22555472	4.7k ohm
R518	22555472	4.7k ohm
R519	22555472	4.7k ohm
R520	22555473	47k ohm
R521	22555473	47k ohm
R522	22555153	15k ohm
R523	22555273	27k ohm
R524	22555102	1k ohm
R525	22555103	10k ohm
R526	22555153	15k ohm
R527	22555473	47k ohm
R528	22555473	47k ohm
R529	22555102	1k ohm
R530	22545473	47k ohm
R531	22555223	22k ohm
R533	22555102	1k ohm

Symbol No.	Part No.	Description
R534	22555102	1k ohm
R535	22555103	10k ohm
R536	22555122	1.2k ohm
R537	22555391	390 ohm
R538	22555103	10k ohm
R539	22555473	47k ohm
R540	22555122	1.2k ohm
R541, 542	22545102	1k ohm
R545, 546	22555104	100k ohm
VR401, 402	22658130	Semi-fixed Resistor, 50k ohm
VR403, 404	22624012	Variable Resistor, 50k ohm
VR405, 406	22658184	Semi-fixed Resistor, 10k ohm
VR407, 408	22658130	Semi-fixed Resistor, 50k ohm
VR409	22625013	Variable Resistor, 10k ohm
VR961, 962	22658380	Semi-fixed Resistor, 100k ohm
R901	22555100	10 ohm
R902	22555473	47k ohm
R903	22555473	47k ohm
R904	22555103	10k ohm
R905	22555103	10k ohm
R907	22545470	47 ohm
R908	22545153	15k ohm
R909	22545472	4.7k ohm
R910	22545472	4.7k ohm
R911	22555104	100k ohm
R912	22545472	4.7k ohm
R913	22555102	1k ohm
R914	22545473	47k ohm
R915	22545103	10k ohm
R916	22555473	47k ohm
R917	22545102	1k ohm
R918	22545103	10k ohm
R919	22555472	4.7k ohm
R920	22555472	4.7k ohm
R921	22555471	470 ohm
R922	22555103	10k ohm
R923	22570302	Metal Oxide Film, 39 ohm, 2W, J
R924	22555471	470 ohm
R925	22555103	10k ohm
R926	22570299	Metal Oxide Film, 22 ohm, 2W, J
R927	22545471	470 ohm
R928	22555103	10k ohm
R929	22555102	1k ohm
R930	22555102	1k ohm
R931	22545471	470 ohm
R932	22555103	10k ohm
R933	22555471	470 ohm
R934	22545332	4.7k ohm
R935	22555102	1k ohm
R936	22563471	Solid, 470 ohm, 1/2W, K
R937	22563479	Solid, 4.7 ohm, 1/2W, K
R938	22555102	1k ohm
R939	22545471	470 ohm
R940	22555103	10k ohm

Symbol No.	Part No.	Description
R941	22545102	1k ohm
R942	22545103	10k ohm
R943	22555473	47k ohm
R944	22545471	470 ohm
R945	22658509	Semi-fixed Resistor, 470k ohm
R946	22658510	Semi-fixed Resistor, 1k ohm
R947	22658508	Semi-fixed Resistor, 100 ohm
R948	22545472	4.7k ohm
R951	22545222	2.2k ohm
R952	22545222	2.2k ohm
R953	22545222	2.2k ohm
△ R954	22563102	Solid, 1k ohm, ½W, K
R961	22555102	1k ohm
R962	22555102	1k ohm
R963	22555102	1k ohm
△ R964	22570270	Metal Oxide Film, 470 ohm, 1W, J
R965	22563222	Solid, 2.2k ohm, ½W, K
R966	22545154	150k ohm
R967	22555472	4.7k ohm
R968	22555472	4.7k ohm
R969	22555103	10k ohm
R970	22555103	10k ohm
R971	22555473	47k ohm
R972	22563391	Solid, 390 ohm, ½W, K
△ R973	22570264	Metal Oxide Film, 150 ohm, 1W, J
R974	22555332	3.3k ohm
R975	22555102	1k ohm
R980	22555103	10k ohm

ACCESSORIES

22902287	Owners Manual
22170398	Cord, Connection
22990374	Cleaner, Head
25838125	Dust Cover

TOSHIBA CORPORATION

2-1, GINZA 5-CHOME, CHUO-KU, TOKYO 104, JAPAN

PRINTED IN JAPAN 22955485 May 1979 