

TURNTABLE

Some plain talk from a manufacturer

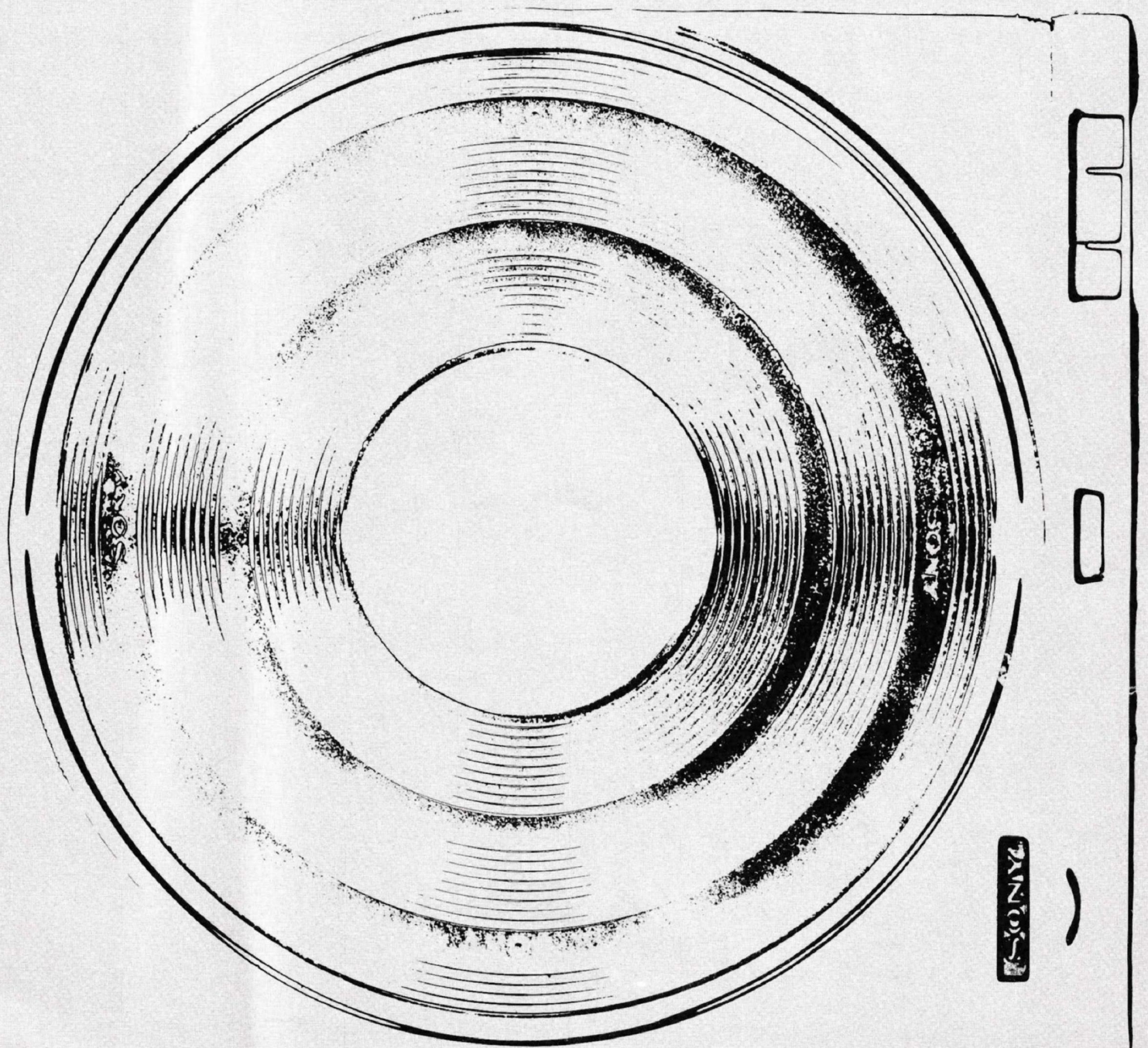
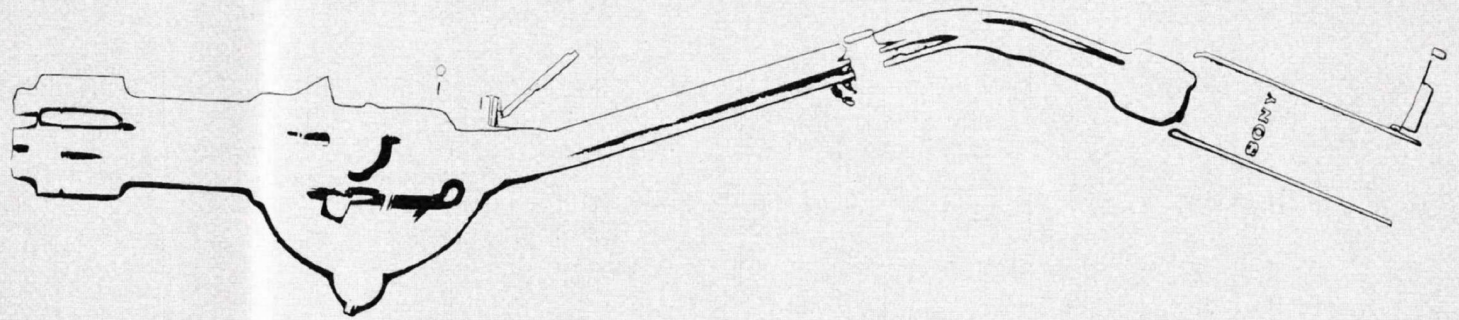

SONY

A phonograph record contains in its grooves a surprisingly great amount of information for quality sound reproduction. To get the most out of the record, it is essential that it is rotated under the conditions equal to or better than those when the original master was made.

- I. The quality of a turntable depends mainly on 1) speed accuracy 2) freedom from speed variations and 3) freedom from mechanical vibrations.

I-1 Speed Accuracy

Pitch of the sound reproduced depends on the speed of the turntable. A mere difference of 0.6% causes the original 440 Hz "A" tone to sound like 443 Hz or 437 Hz. The human ear can perceive a pitch difference of as low as 0.2%.

Nobody would want to hear Berlin Philharmonic under the baton of von Karajan reproduced at the pitch Furtwängler used to hit.

The simplest method to check the turntable speed is watching a stroboscope under a neon, fluorescent, or incandescent light lit by the AC line. The very fast flickering of the light in accordance with the frequency of AC line makes the stroboscope dots stationary at a certain speed. In the areas where the AC frequency is 50 Hz, 180 dots are stationary at 33-1/3 rpm.

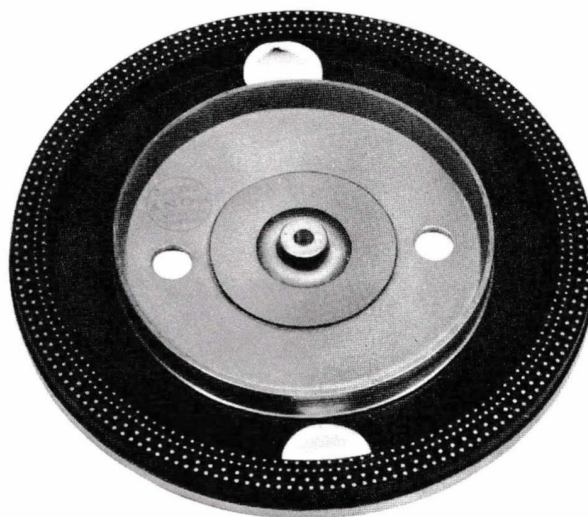

The following table shows the relation between AC line frequency, turntable speed and number of dots on the stroboscope:

Speed (rpm)	Number of dots		Maximum allowable number of dots to move per minutes within 0.2% accuracy	
	50 Hz	60 Hz	50 Hz	60 Hz
45	133	160	- 15 ± 12 *	± 14
33-1/3	180	216	± 12	± 14

* Under the 50 Hz light, the 133 dots actually look stopped at 45.11 rpm. Therefore, at exact 45 rpm the dots should look moving counterclockwise by the amount of 15 dots per minute.

It is possible that the accumulated speed error including that of the tape recorder used for recording, track-down etc. would become so larger that a noticeable pitch difference results. Therefore, a turntable with a fine speed control is extremely convenient. This fine speed adjustment is also a must for “music minus one” or “play-along” applications which require the record to be played at the pitch equal to the pitch of the instrument to be played especially when the instrument has a fixed pitch such as the piano.

To obtain high speed accuracy, the motor has to be very accurate. Also, dimensional accuracy in making the platter driving mechanism has direct effects in achieving high accuracy in speed.

I-2 Freedom from speed variations

Repeated change of turntable speed in a short period is called wow or flutter and causes distortion of reproduced sound as wavering of pitch. This wow or flutter is more perceptible when reproducing decaying single tones such as sustained piano notes, and even 0.1% variations become annoying for critical music listening. Therefore, 0.05% would be an acceptable figure for a high performance turntable.

There are various sources of wow or flutter. Among them are speed stability of the motor itself, dimensional accuracy in making platter driving mechanism such as motor pulley, belt, idler and platter itself etc. and uneven weight distribution of rotating parts.

The following picture shows speed variations of a turntable within a 10 second period:

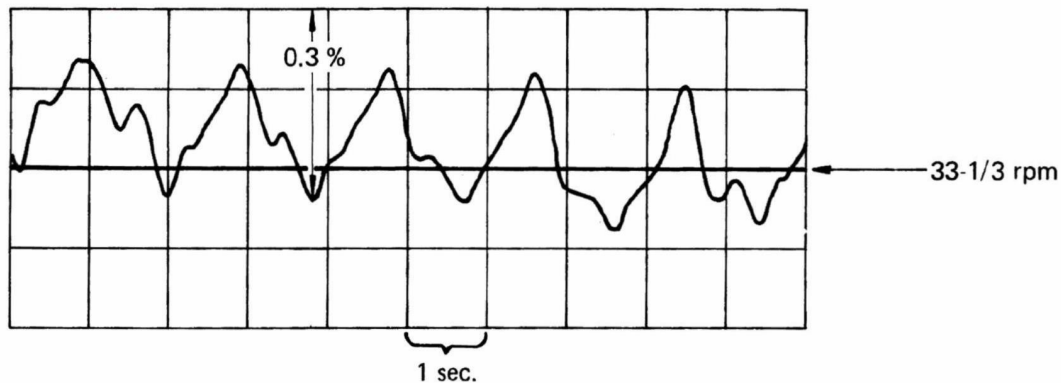

This turntable is shown to have wow of approximately 0.1% at 0.5Hz frequency with some smaller amount of speed variations of much higher frequency. Also, the average speed of this turntable is shown to be a little faster than the standard speed.

I-3 Freedom from mechanical variations

If rotating parts of a turntable system generate mechanical vibrations, they will be transmitted to the surface of the record being played and then the phono cartridge stylus.

Since the vibrations picked up by the phono cartridge are usually of low frequency components, they cause low frequency rumble noise in reproduction or subsonic modulation of the sound being reproduced. Therefore, in addition to the directly audible noise, the mechanical variations would cause inter-modulation distortion in the reproduced sound.

Although there are a few different standards for measuring the amount of vibrations, generally they have to be 50 dB or better when converted into the form of ratio between “rumble” noise and the standard reference record level.

Usually the source of the vibration is a dynamically unbalanced motor rotor, uneven distribution of magnetic field in the motor system and other unevenness in mass, finish etc. in the platter driving mechanism.

II PLATTER DRIVING SYSTEMS

Usually the speed of motor is much faster than the required speed for record playing (33-1/3 rpm or 45 rpm). Therefore, some kind of speed reduction is necessary. The most common speed reduction methods are a rubber wheel called an idler placed between the motor shaft and inner rim of the platter or a belt which links the motor shaft and platter, or combination of the idler and belt.

II-1 Idler Drive

Also called rim drive, this system has one (or more) rubber wheel which transmits the surface speed of the motor shaft, usually in the form of stepped dual-diameter pulley, to the inner rim of the platter. The rubber wheel only “idles” between the motor pulley and the platter and has no effect on the platter speed, hence the name idler.

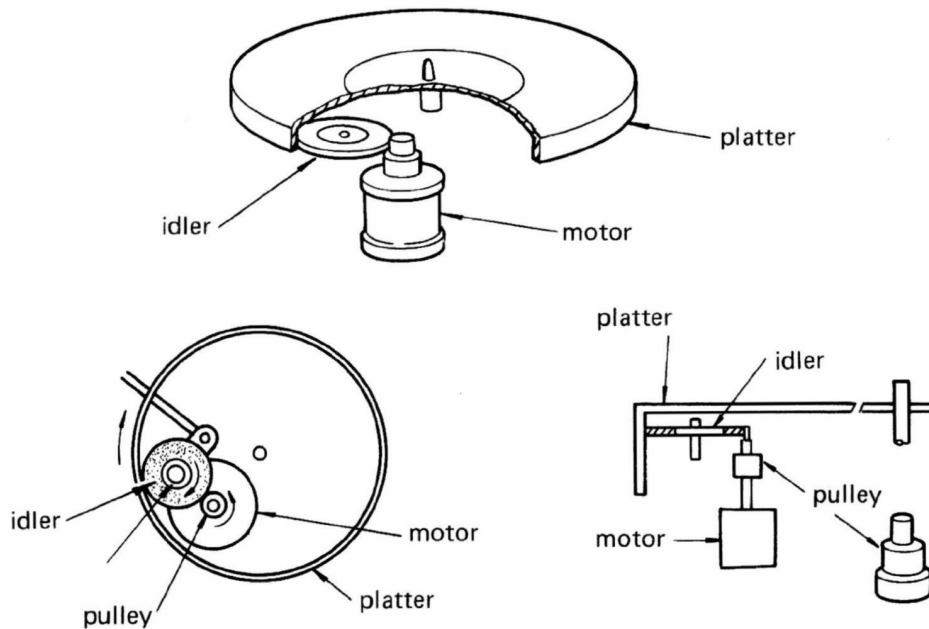

The idler system features simplicity in speed changing and permits a compact player system. On the other hand, the idler material has to be comparably hard, and it could transmit vibrations from motor to the platter causing deterioration of signal-to-noise ratio. Any irregular conditions in the idler or its bearing could cause wow, flutter or rumble. Also, the rubber material is subject to wear and deformation, and periodic replacement of the idler is necessary.

II-2 Belt Drive

In this system the platter is driven by a belt as shown in the illustration.

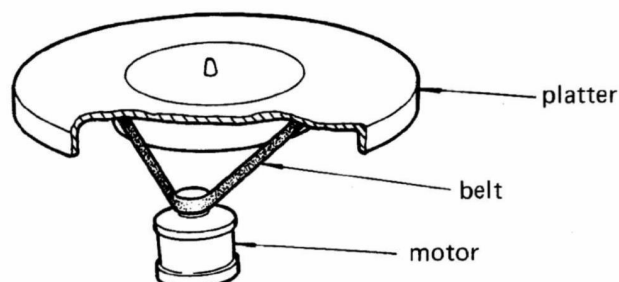

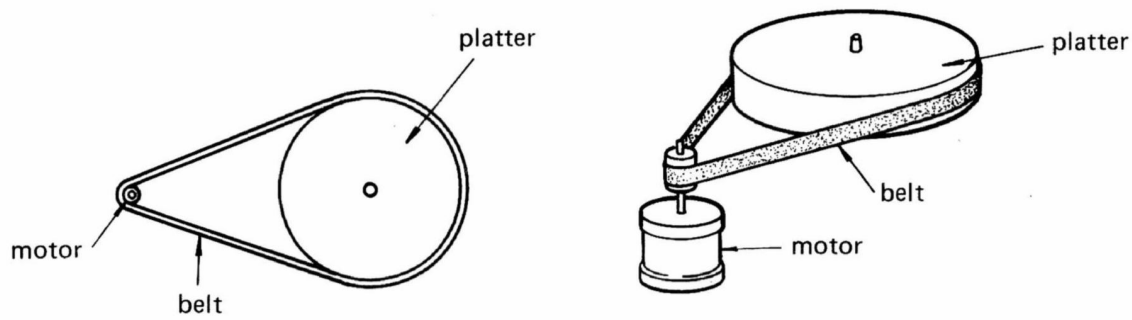

Since elasticity of the belt is considerably higher than that of the idler the belt absorbs a good amount of mechanical vibrations generated at the motor. Therefore, the belt driven turntable systems usually show better signal-to-noise ratio than the idler driven system, and are considered superior. Like the idler, the belt is also subject to wear and deformation and has to be replaced occasionally.

II-3 Direct Drive

The latest technological development in turntable design is the direct drive system. Thanks to pulse counting, closed-loop servo-control system, etc. it is now possible to make, at a reasonable cost, a motor which runs at a very slow speed with extremely high stability.

As shown in the illustration, in the direct drive system, the spindle of the motor is the spindle of the turntable eliminating all the intermediate speed reduction mechanisms no belt, no idler, etc.

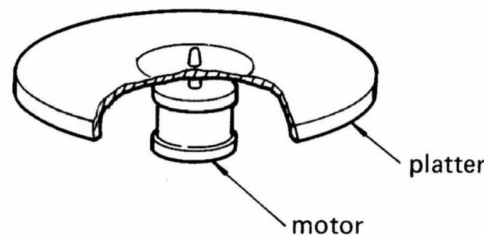

Speed of the motor (33-1/3 rpm or 45 rpm) is considerably lower than the motor speed of conventional drive systems (1,500 rpm at 50 Hz for a 4-pole synchronous motor). Therefore, it has much less mechanical vibrations to cause rumble noise, since the amount of vibrations due to unbalance of dynamic weight distribution of rotating objects is a function of the speed.

II-4 Other system

There are a small number of turntables which utilize combinations of idler and belt driving systems. Ideally, this system is supposed to provide the merits of both idler and belt systems.

II-5 Comparison of Different Driving Systems

The following table compares the different platter driving system:

	Idler-driven System	Belt-driven System	Direct-driven System
Wow/Flutter	Flutter components high, due to idler finish and material	Better than idler system. Wow components high due to belt slippage	Virtually non-existent
Rumble	High due to hard idler material and motor support	Good, due to softer motor mounting and belt material	Virtually non-existent due to slow speed and simple mechanism

	Idler-driven system	Belt-driven system	Direct-driven system
Starting	Excellent	Fair	Good
Speed accuracy	Depends on dimensional accuracy of motor pulley etc. Could be very good if motor is servo-controlled type with fine speed adjustment	Same as idler system	Excellent due to servo-control system
Motor	Could be comparably small due to speed reduction	Same as idler system	Larger motor is required to give sufficient rotating torque
Maintenance	Motor needs periodical lubrication. Idler has to be replaced approximately once a year	Motor needs periodical lubrication. Belt has to be replaced approximately once a year	Needs no lubrication for as long as 5000 hours. No idler or belt to replace

III TURNTABLE MOTORS

The prime requisites for a turntable motor are constant, steady speed, minimal amount of mechanical vibrations, enough torque to make starting reasonably fast and to prevent speed variations from stylus pressure and facility for fine speed adjustment (either external or internal). Also, minimal magnetic flux leakage from the motor is an important requirement for low noise reproduction.

Motors used for quality turntable systems include induction, hysteresis synchronous, servo-controlled DC and servo-controlled AC types.

III-1 Induction Motor

Rotor of an induction motor is made of many copper bars and is placed within a rotating magnetic field generated by the stator coils. Since speed of this type of motor is theoretically slower than the speed of rotating magnetic field and is subject to the supply voltage and external load, a fine speed adjustment is usually provided.

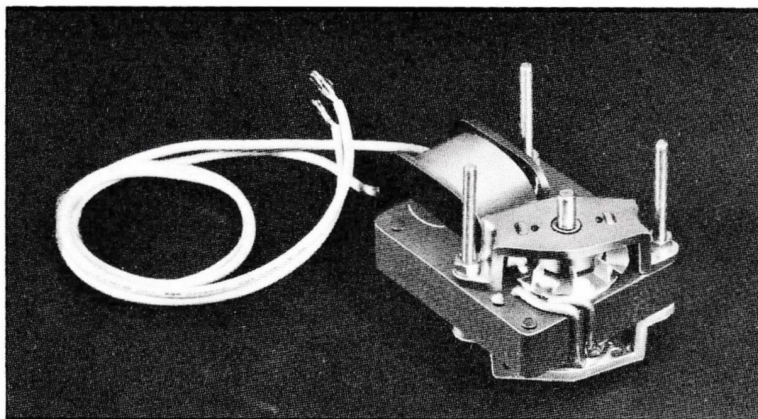

III-2 Hysteresis Synchronous Motor

Hysteresis synchronous motor consists of a stator which generates rotating magnetic field with the aid of a phase splitting capacitor and a rotor made of magnetic steel. The magnetic

energy generated by hysteresis characteristics of the rotor under the rotating magnetic field makes the rotor rotate. The speed is in synchronization with the speed of the rotating magnetic field usually powered by the AC line. Theoretically the rotating torque is smoother than that of the induction type, and physically it is easier to obtain a better balanced rotor. Therefore, hysteresis synchronous motors have usually smaller mechanical vibrations than induction motors.

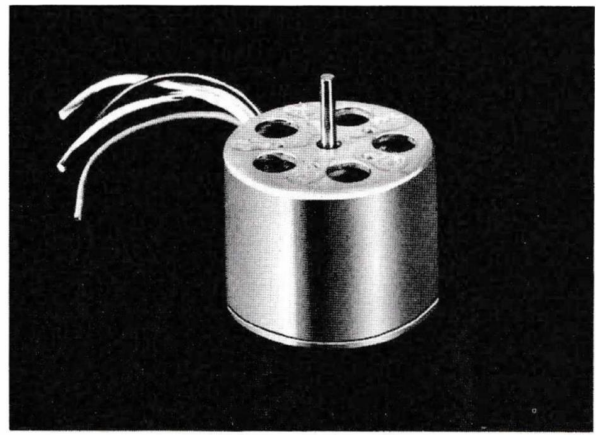

III-3 Servo-controlled Motor

A servo-controlled motor consists of a motor, the speed of which is controllable by varying supply voltage, a frequency or voltage generator which generates information in accordance with speed of the motor, and an electronic circuit which processes the information and feeds it back to the motor to control the speed. By properly designing the system, it is possible to obtain very high speed accuracy at a very slow speed. The motor portion of this system can be either DC type or AC type. When compared to an AC motor, a DC motor has, due to its uneven, stepping magnetic field strength, higher flutter components which have to be absorbed by use of a belt and/or heavier platter.

Despite higher cost in manufacturing, use of the servo-controlled motor in turntable system are becoming more and more popular due to ever-increasing demands for higher performing turntables.



AC servo-controlled motor

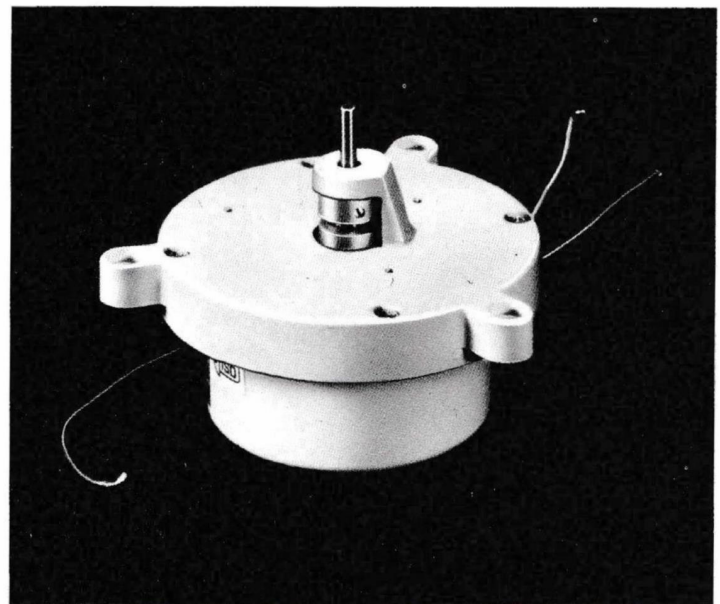

DC servo-controlled motor

IV SONY DIRECT-DRIVE TURNTABLE

As mentioned earlier, direct-driven turntables can perform better than other driving systems in every aspect. Turntables of this type have been announced from several manufactures. Currently there are two models available from SONY (TTS-2250/PS-2250 and TTS-4000). Both feature AC eddy-current motors with a specially designed cup-shaped copper rotor which generates smooth, linear rotating torque. As the illustration shows, the motor shaft serves as the turntable spindle. The associated electronics are housed underneath the platter.

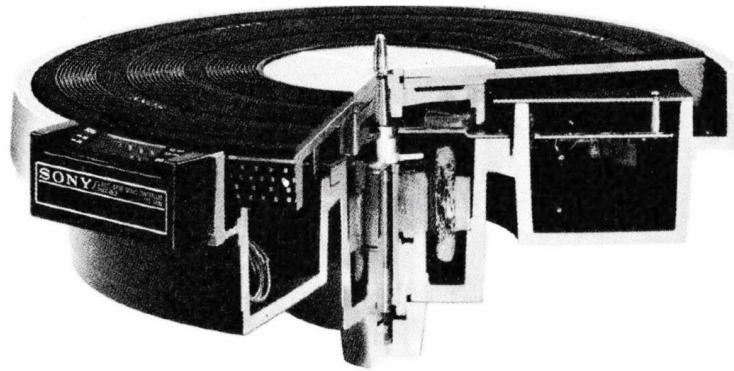

There is a frequency generator coaxially mounted on the motor. Frequency of the generator varies in direct proportion to the speed of the motor, and is used as the information for precise speed control.

Unlike the DC motor, which inherently generates a certain amount of flutter components due to non-linear characteristics of torque, the AC motor of the SONY system provides virtually non-existent wow and flutter with a comparatively light-weight platter. In fact, the wow and flutter, as well as rumble, of the SONY system are so low that inherent wow, flutter and rumble components of conventional test records interfere with measuring of actual capabilities. Also, the speed of the SONY system is so stable that occasional drift of the built-in stroboscope dots is mostly due to drift of AC power line frequency on which flickering of the neon light depends. The actual speed of the motor is immune to both frequency and voltage fluctuations of the AC lines.

The following table shows the specifications of the SONY direct-driven turntables:



TTS-2250

Speeds:	33-1/3 rpm and 45 rpm
Speed control range:	± 4%
Drive system:	Direct-drive system
Motor:	AC servo motor
Starting time:	Within 3/4 revolution at 33-1/3 rpm
Flutter and wow:	Less than 0.04% wrms
Rumble:	Less than - 58 dB
Turntable platter:	31cm (12-13/16"), diecast aluminum
Power requirements:	AC 100, 120, 220, 240V : 50/60 Hz (110, 127, 220 240V for Europe)
Power consumption:	15 watts (23 watts-Max.)
Weight:	16 lb 8 oz (7.5 kg)
Dimensions:	12-15/16(W) x 5-3/4(H) x 14-1/16"(D) (328 x 146 x 357mm)



TTS-4000

Speeds:	33-1/3 rpm and 45 rpm
Speed control range:	± 3%
Starting time:	Within 1/2 revolution
Drive system:	Direct-drive system
Flutter and wow:	Less than 0.03% wrms
Rumble:	Less than -60 dB
Turntable waging:	Within + 0.05mm
Power requirements:	100, 120, 220, 240V: 50/60 Hz (110, 127, 220, 240V for Europe)
Power consumption:	17 watts
Turntable platter:	32cm (12-5/8") diecast aluminum, 3 lb 13 oz (1.75 kg)
Weight:	21 lb 9 oz (9.8 kg)
Dimensions:	Turntable 13-1/2 (maximum dia.) x 5-3/4"(H) (343 x 145.6mm) Control box 4-9/16(W) x 3-7/16(H) x 2-5/8"(D) (116 x 87 x 66mm)

SUPPLEMENT

SONY DIRECT-DRIVEN AC SERVO-CONTROLLED TURNTABLE SYSTEM

This report explains the theory of operation of the SONY direct-driven turntable system.

1. Why Direct-drive?

In speed transmission mechanisms, irregularity in finish, weight distribution etc. in the components cause speed variations. The turntable system is no exception. Any irregularity in motor pulley, idler, belt, platter, bearings etc. cause speed variations which appear as wow and flutter. Therefore, reduction of number of components in speed transmission mechanisms leads to reduction of the wow and flutter.

Also, since the mechanical vibrations of a rotating object due to dynamically unbalanced weight distribution is a function of its speed, the slower the speed of a turntable motor, the less the vibrations which cause "rumble".

Another merit of the direct-drive system is the fact that the extremely slow speed and balanced pressure applied to the bearings make the life expectancy of the direct-driven turntable much longer than the belt- or idler-driven system.

2. The Motor

For direct-drive design it is essential that the motor runs at $33\frac{1}{3}$ rpm and 45 rpm. In practice, this requires that the speed of the motor be independent of the AC power frequency. In all currently available direct-driven turntables, either DC motor or AC torque motor with associated servo-control electronics is used.

The DC motor, due to its non-linear rotating torque, generates “cogging” when in motion. This would require a heavier platter to absorb the wow or flutter components. AC induction motors, on the other hand, could provide a very linear rotating torque as well as low mechanical vibrations when the rotor is made of non-magnetic metal. SONY turntables, use an eddy-current induction motor having a cup-shaped copper rotor as shown in the picture.

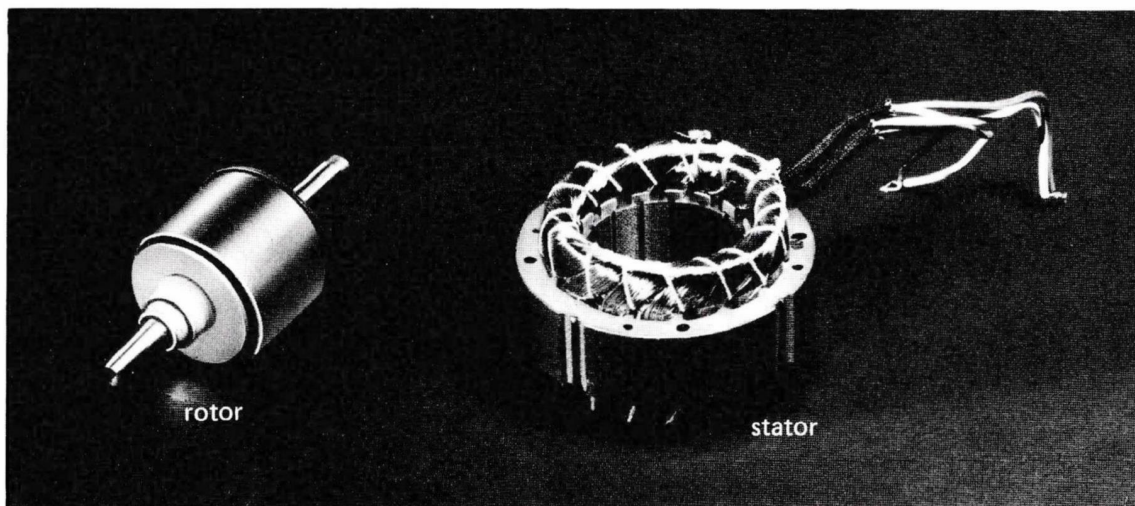
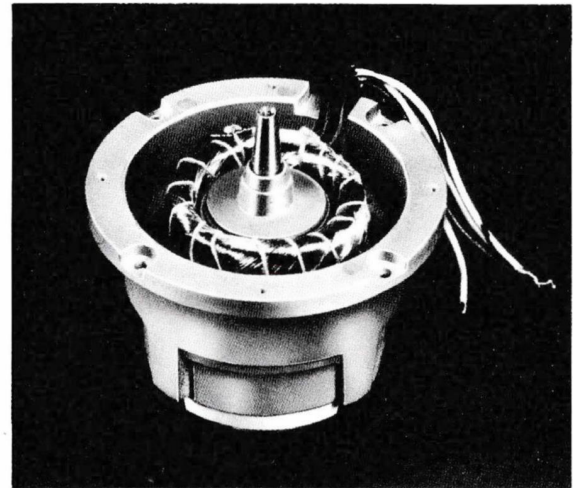

3. Servo-control System

The following is a block diagram of the servo-control system of the SONY turntable:

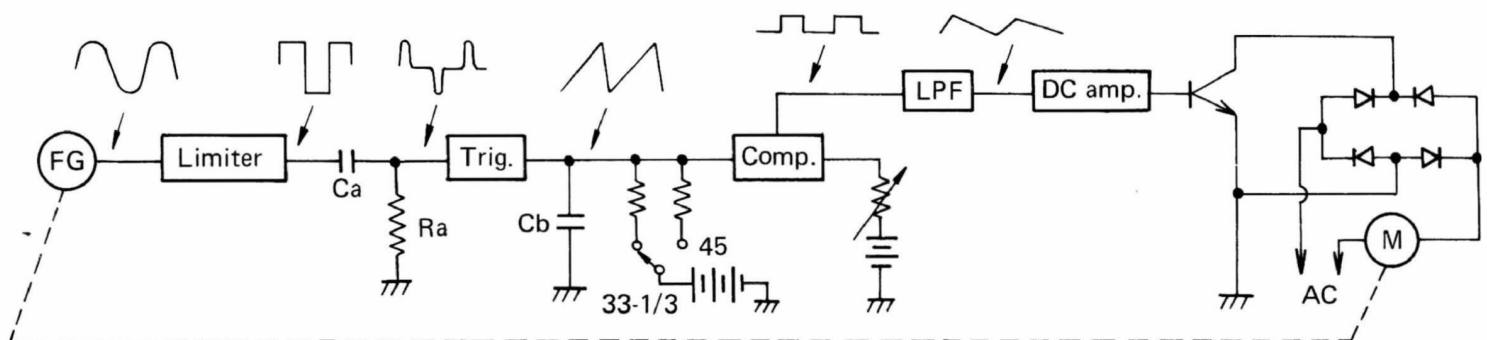

When the power is turned on, the motor control transistor becomes fully conductive and starts the motor. Then, the frequency generator (FG) supplies signals to the servo-control electronics. The sinusoidal waveform of the FG passes through a two-stage limiter to

eliminate AM components and is then differentiated by Ca and Ra to form sharp pulses, the intervals of which are in direct proportion to the frequency of FG. The pulse triggers a saw-tooth generator, the time constant of which is determined by Cb and Rb or Rc. The height of the saw-tooth wave, which varies as the interval between pulses changes, is supplied to a back-to-back connected voltage comparator, one side of which is connected to a stabilized reference potential through a fine voltage adjustment. Output from the comparator appears only for the period when the potential of saw-tooth wave becomes higher than the reference potential. The signal then goes through a low-pass filter for integration and smoothing. The smoothed DC potential, which varies in direct proportion to the width of the pulses at the input of the low-pass filter, is supplied to a DC amplifier to control the internal impedance of the power transistor connected in series with the motor.

The following chart shows the relation between motor speed and operation of the servo-control system:

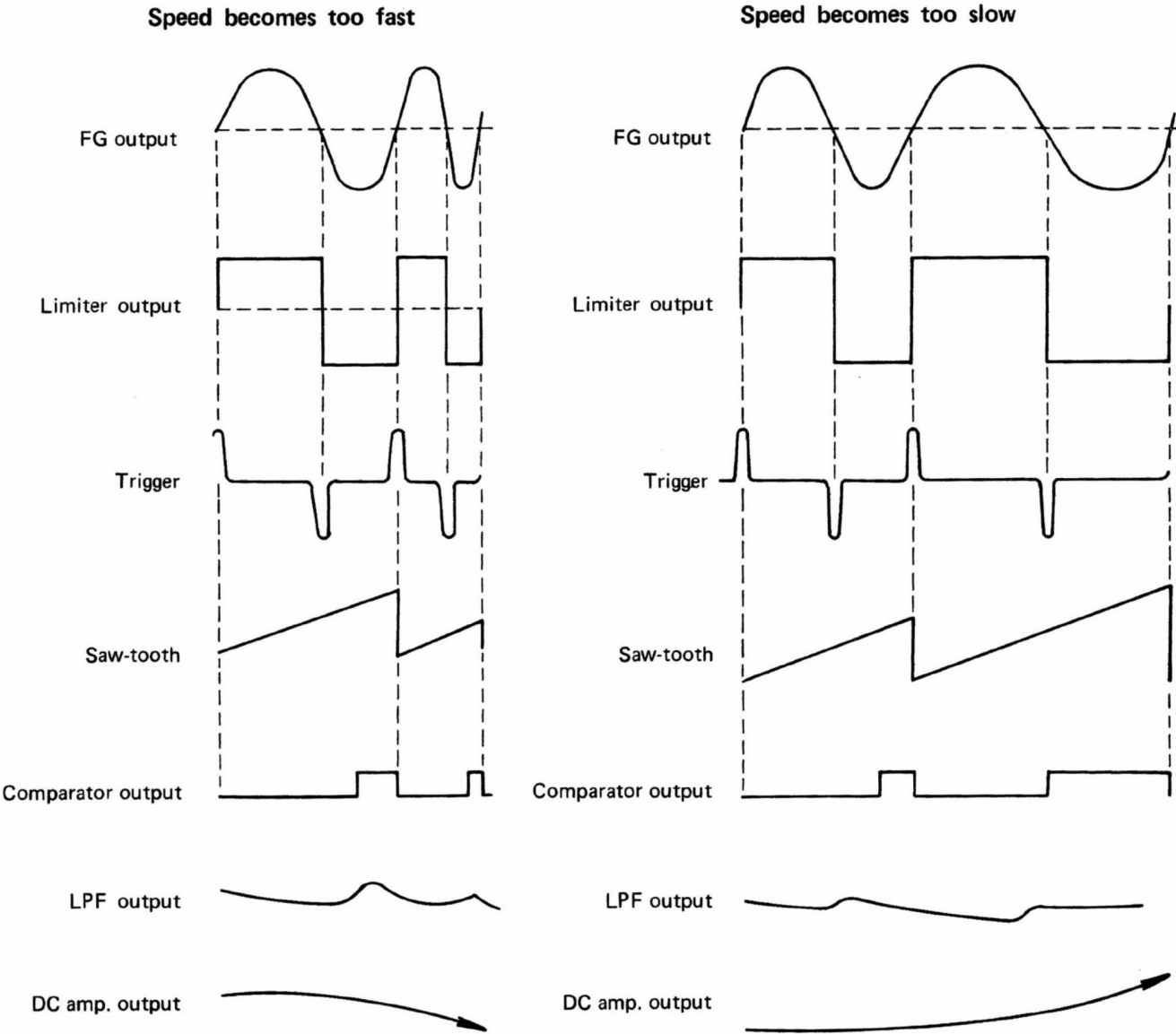

If the motor speed is accelerated, the FG frequency will become higher than the predetermined figure, which results in a shorter interval between the pulses for saw-tooth triggering. This will cause lower saw-tooth wave height, which in turn brings in a narrower pulse width at the output of the comparator. Narrower pulse width will then cause less output potential at the DC amplifier making the internal impedance of the motor control transistor high to reduce the motor speed. When the motor speed becomes slower than the predetermined value, servo system adjusts the speed by reverse operation.

SONY CORPORATION