

# PIONEER®

13450



## SOLID STATE HI-COMPACT STEREO SYSTEM

# C-6000

### OPERATING INSTRUCTIONS

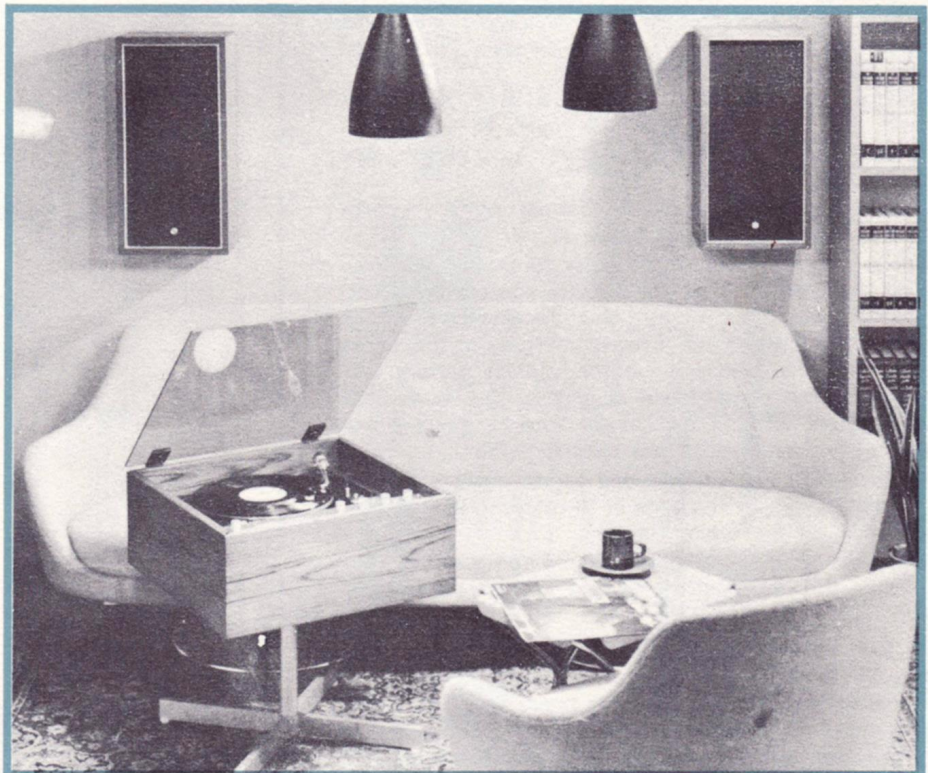

### FEATURES OF MODEL C-6000

- **FM Tuner with Highest Sensitivity**  
High-performance mesa-transistors are employed in the FM front end, insuring the outstanding sensitivity and stability in performance.
- **Stereo/Mono Automatic Switching MPX Circuit**  
New FM MPX circuitry featured with automatic switching electronics insures the lowest distortion and best stereo separation, while eliminating nuisance of manual stereo/mono program switching.
- **Dynamic, true reproduction of sound**  
High-performance complementary transistors are employed in the SEPP output stage, completely eliminating transformers from the entire amplifier circuits. This state-of-the-art direct coupled circuitry has made possible high output wattage with outstanding reproduction characteristics.
- **Hi-Class Automatic Tone-Arm Return Mechanism**  
This player employed high-performance belt-driven system, realizing the dream of many music lovers. Automatic tone-arm return with automatic power-off is the additional feature of this player.
- **Unique PIONEER Style Design**  
PIONEER'S masterpiece in cabinet design—totally different from conventional stereo-cabinet concepts. Matched along fully ultra-modern lines, the classical finish and tone create the deluxe atmosphere in your room.

PIONEER ELECTRONIC CORPORATION

## Instructions for Use of Stereo Rack for Model C-6000 Hi-Compact Stereo System

### Assembling of Stereo Rack

1. Insert the support pole in the center hole of the crossed base, and mount the pole to the base with the nut, using the furnished wrench.
2. Install the cabinet support on the support pole. The cabinet support has four tapped holes around its center. Using these holes, the cabinet support can be joined to the support pole with bolts. Before securing, be sure that the arms of the cabinet support are due above the arms of the crossed base.

### Mounting C-6000 on Stereo Rack

1. Lay a soft mat or carpet on the floor and place the cabinet with the glass cover down, carefully holding the glass cover by hand.
  - Turning over the cabinet without holding the glass cover by hand may cause the cover to open itself abruptly with spring force, resulting in serious damage to the cover.
2. Remove the rubber legs on the bottom corners of the cabinet, using the furnished screw driver.
3. There is a set of four screw holes (protruded portions) around the center top of the cabinet support. And there is another set of four screw holes (recessed portion) on the center bottom of the cabinet. Turn over the entire stereo rack, and mount it on the cabinet bottom with the two sets of screw holes aligned on the same position. The four arms of the cabinet support should agree with the diagonal lines of the cabinet bottom.
4. Using screws, plain washers, and spring washers furnished in the kit, fasten the ends of arms to screw holes at the corners of the cabinet bottom.
5. Using wood screws and plain washers furnished in the kit, fasten the center of the cabinet support to the cabinet.
6. Turn over the cabinet-rack assembly, carefully holding the glass cover by hand.
7. If the floor surface is uneven and the rack stands unstable on the floor, use the adjuster provided on the bottom of each arm end of the crossed base for making it stable.

### ATTACHMENTS FURNISHED IN THE KIT

- |   |          |
|---|----------|
| 1. Screw Driver                                 | one each |
| 2. Round Head Screw, $4\phi \times 25\text{mm}$ | 8 each   |
| 3. Wood Screw, $3.5\phi \times 25\text{mm}$     | 4 each   |
| 4. $4\phi$ Plain Washer                         | 12 each  |
| 5. $4\phi$ Spring Washer                        | 8 each   |
| 6. $10\phi$ Plain Washer                        | 1 each   |
| 7. $10\phi$ Spring Washer                       | 1 each   |
| 8. $10\phi$ Hex-Head Nut                        | 1 each   |
| 9. Wrench                                       | 1 each   |

### SPECIFICATIONS

1.6mm Steel Sheet (Cabinet Support)  
 Aluminum Alloy (Support Pole, Crossed Base)  
 Dimensions (Cabinet-Rack Assembly):

- Cabinet Support 427 (W)  $\times$  424 (D) mm
- Crossed Base 417 (W)  $\times$  417 (D) mm
- Height (from floor to the cabinet bottom) 332mm
- Weight 4.2 kg

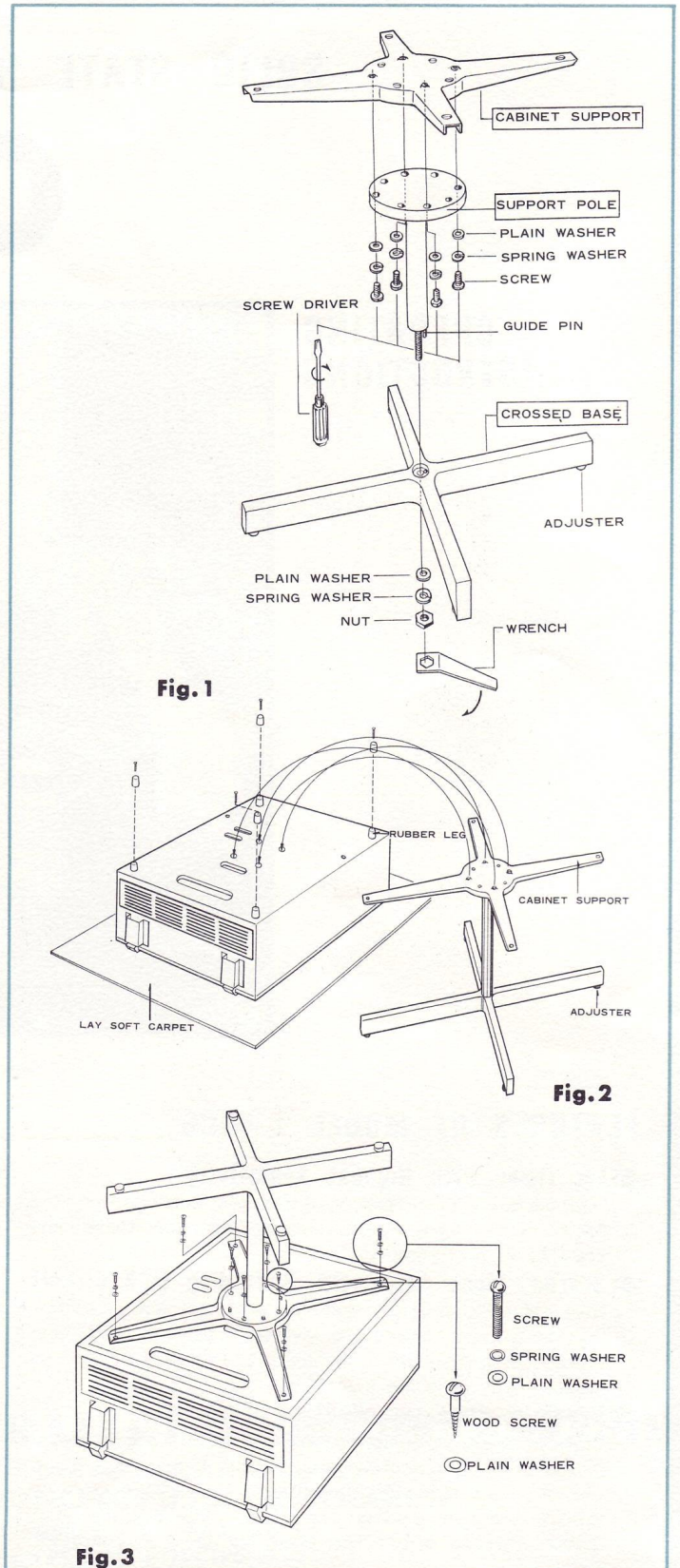

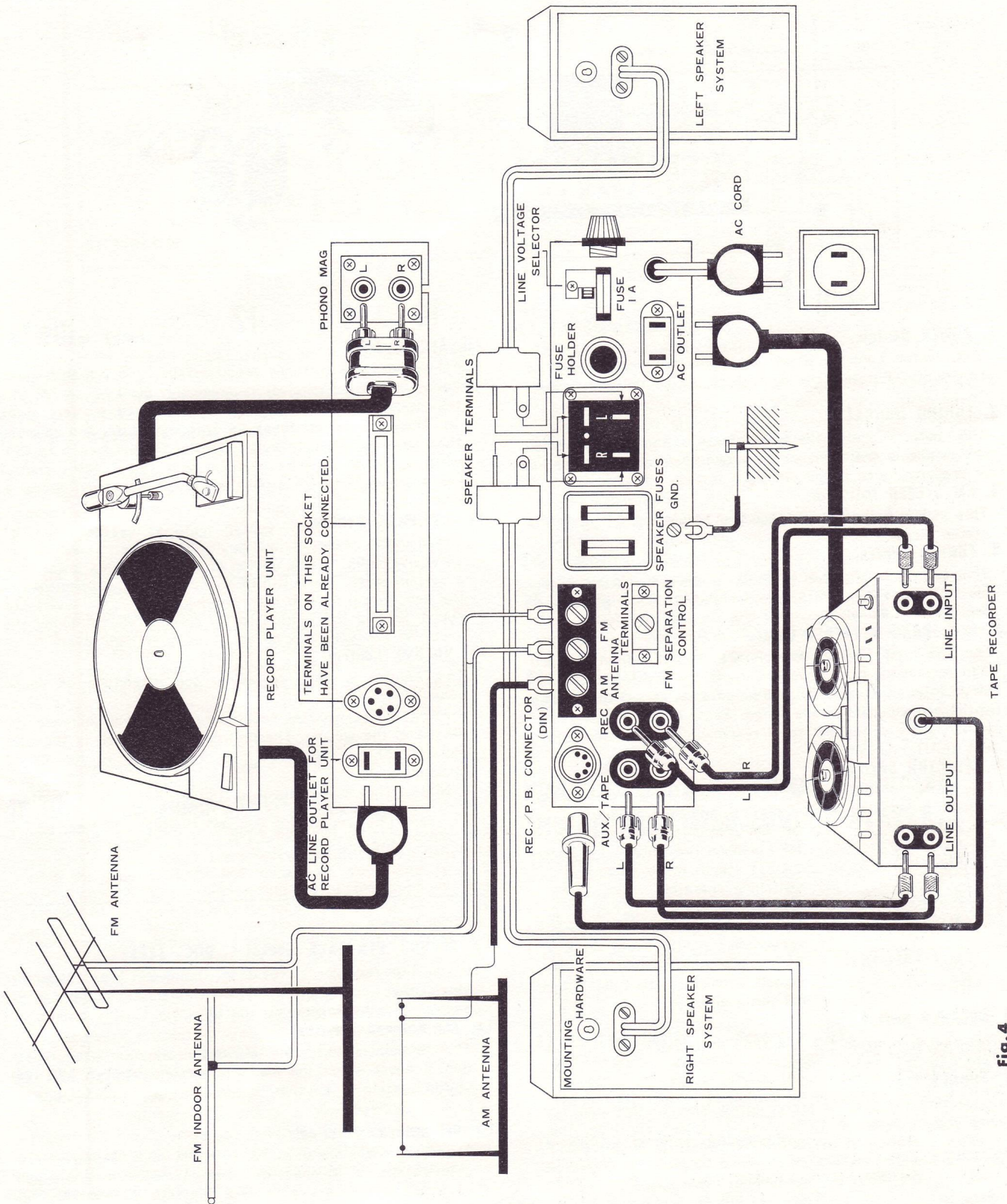

Fig. 4

## FUNCTIONS OF CONTROLS AND SWITCHES ON FRONT PANEL

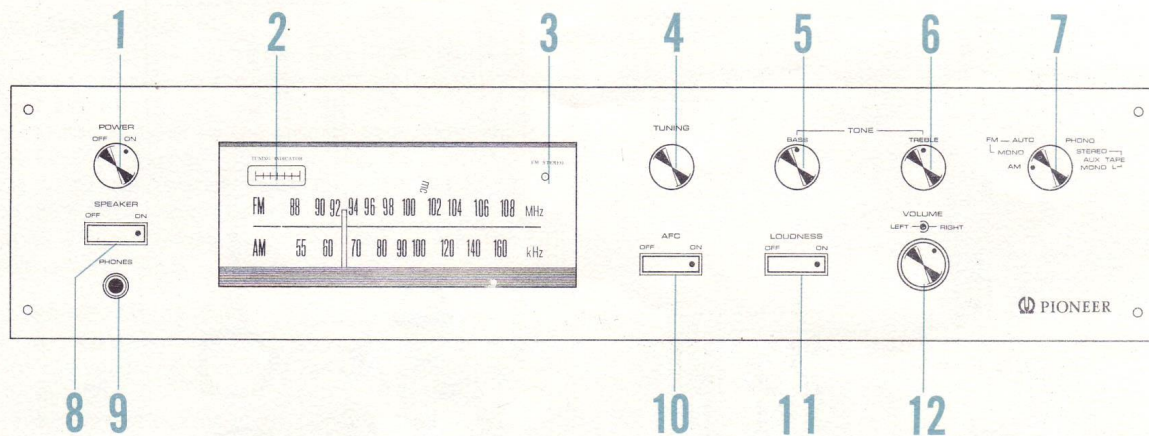

Fig. 5

### 1. POWER Switch

This switch controls power for both the amplifier and record-player. Rotating the control clockwise will turn power on.

### 2. TUNING INDICATOR

This meter indicates the tuning state of the receiver. When the needle is deflected all the way to the right, a station is properly tuned in.

### 3. FM STEREO Indicator

This indicator flashes on when the receiver picks up an FM stereo signal.

### 4. TUNING Control

This control is adjusted to select a desired station in any band of AM, FM or FM Stereo, depending on the position of the SELECTOR switch.

### 5. & 6. BASS & TREBLE Controls

The BASS and TREBLE controls are used to adjust low and high responses, respectively. Turning the controls clockwise (or counter-clockwise) will increase (or decrease) the volume in the corresponding tonal range. Each of the controls simultaneously varies the tonal response of both the LEFT and RIGHT channels.

### 7. SELECTOR Switch

This switch conditions the receiver to a variety of input signals; broadcasts, record playing, and tape playback.

AM	for AM (medium wave) reception
FM-MONO	for FM-mono reception
FM-AUTO	for FM stereo/mono automatic switching operation
PHONO	for record-playing
AUX/TAPE-STEREO	for reproducing stereo signals applied on the AUX/TAPE terminals
AUX/TAPE-MONO L	for monoral reproduction of the signals applied on the L(left) channel terminals

### 8. SPEAKER Switch

This switch controls the operation of speakers. Setting the switch to OFF mutes speakers.

### 9. PHONES Jack

Connecting the plug of stereo-headphones to this jack permits you to listen in to the music, separately from the speaker operation. If the SPEAKER switch (8) is set to OFF, only the headphones will be operated, and if the switch (8) is set to ON, both the headphones and speakers will be operated.

### 10. AFC Switch

FM programs are usually broadcasted on very high frequencies. Even if the receiver is precisely tuned to an FM station, it tends to "drift" or to detune itself as time goes on. This AFC circuit functions to compensate and prevent the unwanted detuning automatically. Set the switch to OFF when a station is being tuned in with the TUNING control (4), and turn it to ON after the station has been properly selected.

### 11. LOUDNESS Contour

The human's sense of hearing is drastically weakened in lows and highs as the volume of sound becomes lower than a certain level. This LOUDNESS contour circuit compensates the sensational loss in lows and highs at low levels of sound. Setting this switch to ON permits you to enjoy the music at low volume level as good as at high level.

### 12. VOLUME Control

This control is used to adjust the magnitude of sound volume.

Turning it clockwise (or counterclockwise) will increase (or decrease) the volume. The protruded, inner knob is the control for LEFT channel, and the outer knob is for RIGHT channel.

NOTE: This is a concentric friction-clutch type control.

When volumes of both channels are separately adjusted, hold one knob with the finger while adjusting the other knob.

### 13. RECORD/PLAYBACK Socket ("DIN" TYPE)

If your tape recorder is provided with the DIN type connector plug, either recording or playback thru this amplifier can be simply made by connecting the DIN plug to this socket.

### 14. AM Antenna Terminal

This terminal is used for AM (medium wave) program reception. Connect either the lead-wire antenna supplied with this stereo system or a separate AM antenna installed outdoors, to this terminal.

### 15. FM Antenna Terminals

These terminals are used for both FM and FM-stereo program receptions. Connect either the T indoor-antenna supplied with this stereo system or a separate FM antenna installed outdoors, to these terminals.



## FUNCTIONS OF TERMINALS AND SWITCHES ON REAR PANEL OF AMPLIFIER

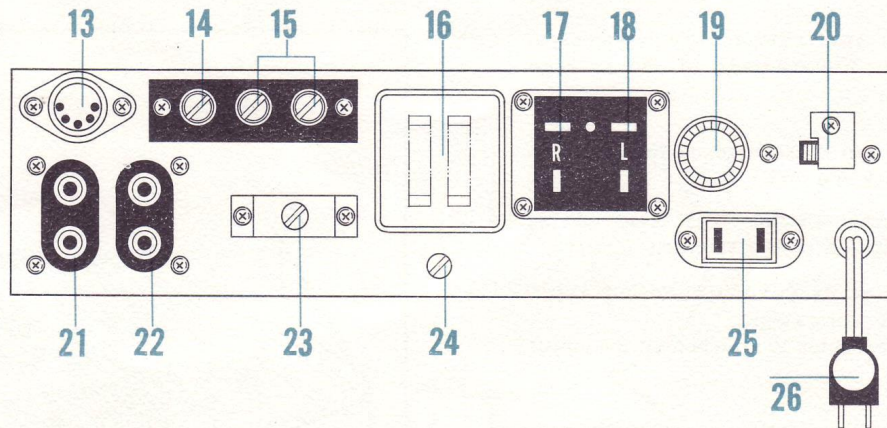

Fig. 6

### 16. Speaker Fuses

These fuses protect power transistors in the output stages against possible short-circuit in the speaker circuits. Each fuse is rated for 0.5-ampere fuse encased in glass-tube. Use of wrong fuse may cause damage to the amplifier.

### 17. Right Speaker Terminal Socket.

Connect the right channel speaker system to this socket. The cable coming from the rear of the right channel speaker system has a plug on its end. Connect securely the plug into the socket with red mark up.

### 18. Left Speaker Terminal Socket

Connect the left channel speaker system to this socket, as in the procedure for the right speaker terminal socket above.

### 19. Fuse Holder

This fuse protects the amplifier section of Model C-6000. NOTE: A 0.5-ampere fuse is installed when delivered from the factory. If the line voltage in your area is 115V, replace it with a one-ampere fuse. The fuse rating should vary with the line voltage as shown below:

Line Voltage	Fuse Rating
230 volts	0.5 ampere
115 volts	1.0 ampere

Note that improper selection and use of fuse may cause damage to the amplifier.

### 20. Line Voltage Selector Switch

This switch conditions the unit for either 230V or 115V operation, depending on the line voltage in your area. The switch is set to 230V line-voltage operation when delivered from the factory. If the line voltage in your area is 115 volts, change the switch position to 115V. Remove the stopper (die-stamped 230V) by loosening the screw holding it to the chassis, turn it over so that the stopper indicates the die-stamped letters 115 volts, and then secure the stopper to the chassis by re-tightening the screw.

### 21. AUX/TAPE Terminal Jacks

Connecting the LINE OUTPUT terminals to these terminals permits you to play back the recorded tape thru the amplifier of Model C-6000. TV outputs or the like may also be reproduced thru the amplifier in the similar manner.

### 22. REC Terminal Jacks

Connection of the LINE INPUT terminals of your tape recorder to these terminals makes it possible for you to record the music while you listen to it. Since any signals being played on C-6000 appear across these terminals, the SELECTOR switch (7) also controls selection of signals to be recorded on tape when terminals are connected to LINE INPUT terminals of your tape recorder.

### 23. FM Separation Control

This control is used to adjust the separation of FM stereo program.

\*Model C-6000 is delivered from the factory after complete separation adjustment. Do not move the control setting unless the FM stereo program separation is noticeably poor. In this case, receive the separation test signal from an FM station, and adjust this control with a screw driver by moving the control position slightly left and right for best separation.

\*When the separation is extremely poor, contact your service man for proper adjustment.

### 24. Grounding Terminal

This terminal is used to ground the stereo unit.

### 25. Auxiliary AC Line Outlet

This outlet provides AC line power to external units such as tape recorder with current up to 2 amperes. The POWER switch (1) controls the power supplied thru this outlet.

### 26. AC Line Cord

AC line power is supplied to C-6000 thru this cord. Connect the plug to a wall socket after necessary assembling and wiring are complete.

## FUNCTIONS OF TERMINALS LOCATED INSIDE AMPLIFIER (UNDER PLAYER DECK)

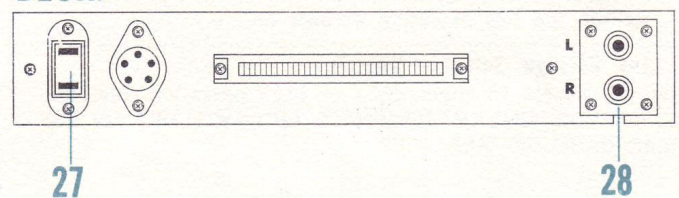

Fig. 7

### 27. AC Line Outlet for Record Player

AC power is supplied to the record player thru this outlet. Connect the line cord of the record player to this outlet. The POWER switch (1) located on the front panel controls power to the record player.

### 28. PHONO Terminal Receptacle

Connect the plug on player output cord to this terminal receptacle. Be sure that letters L and R marked on the plug agree with those on the receptacle.

## ATTACHMENTS AND PREWIRING OF RECORD PLAYER

The record player unit and its attachments are packed separately in the same package. The contents of the package are as follows:

- Player Unit (The pick-up arm is mounted on the unit with cartridge. Carefully unpack the unit.)
- Turntable Platter and Rubber Cushion (The drive belt is installed around the periphery of the turntable platter.)
- Oil Feeder, Stylus Pressure Gauge, 45-rpm Record Adapter, Small Screw Driver, Counterweight.

NOTE: The replacement capstan is attached on the player unit.

1. Before mounting the turntable platter in the player unit, connect the player AC line cord to the AC line outlet (27) and also the player output plug to the PHONO terminal jacks (28), while raising the player unit as shown in Fig. 4. Be sure that the letters L and R marked on the player output plug agree with those on the jacks.
2. After the prewiring is complete as stated above, place the player unit in the cabinet and adjust its position so that four rubber legs located underneath the player deck exactly fit onto the respective holes.

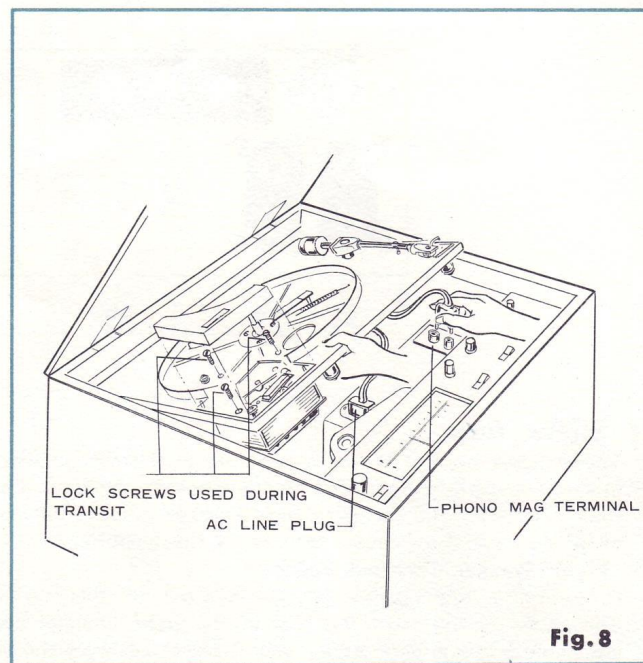

Fig. 8

## HOT TO ASSEMBLE RECORD PLAYER

### 1. AC Line Frequency

Prior to shipment of Model C-6000 to a certain area, operation of the unit is conditioned at the factory for the specific line frequency of the area. If the unit is transferred from an area to a different line-frequency area (from 50-Hz area to 60-Hz area, or vice versa), the capstan on the player unit must be replaced for proper player operation.

### 2. How to Replace Capstan

- 1) Loosen two mounting screws at the bottom of the capstan and remove the capstan from the motor shaft.
- 2) Mount the proper capstan on the motor shaft.
- 3) Adjust the capstan section comes exactly on the center of the tape shift guide as shown in Fig. 10, and then tighten the two mounting screws securely.

### 3. Line Voltage Selector Switch

Set this switch to either 230V or 115V operation. See para. 20 of FUNCTIONS OF TERMINALS AND SWITCHES ON THE REAR PANEL OF AMPLIFIER

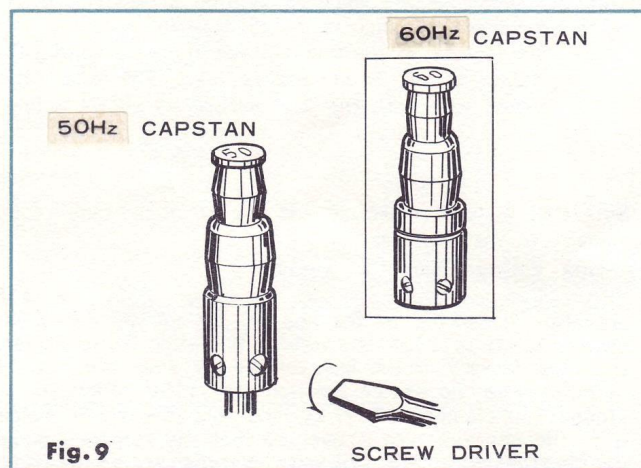

Fig. 9

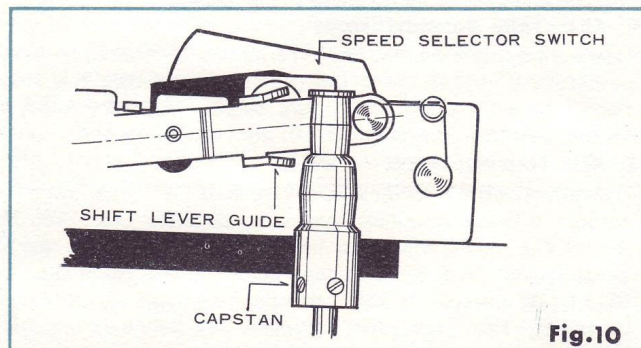

Fig. 10

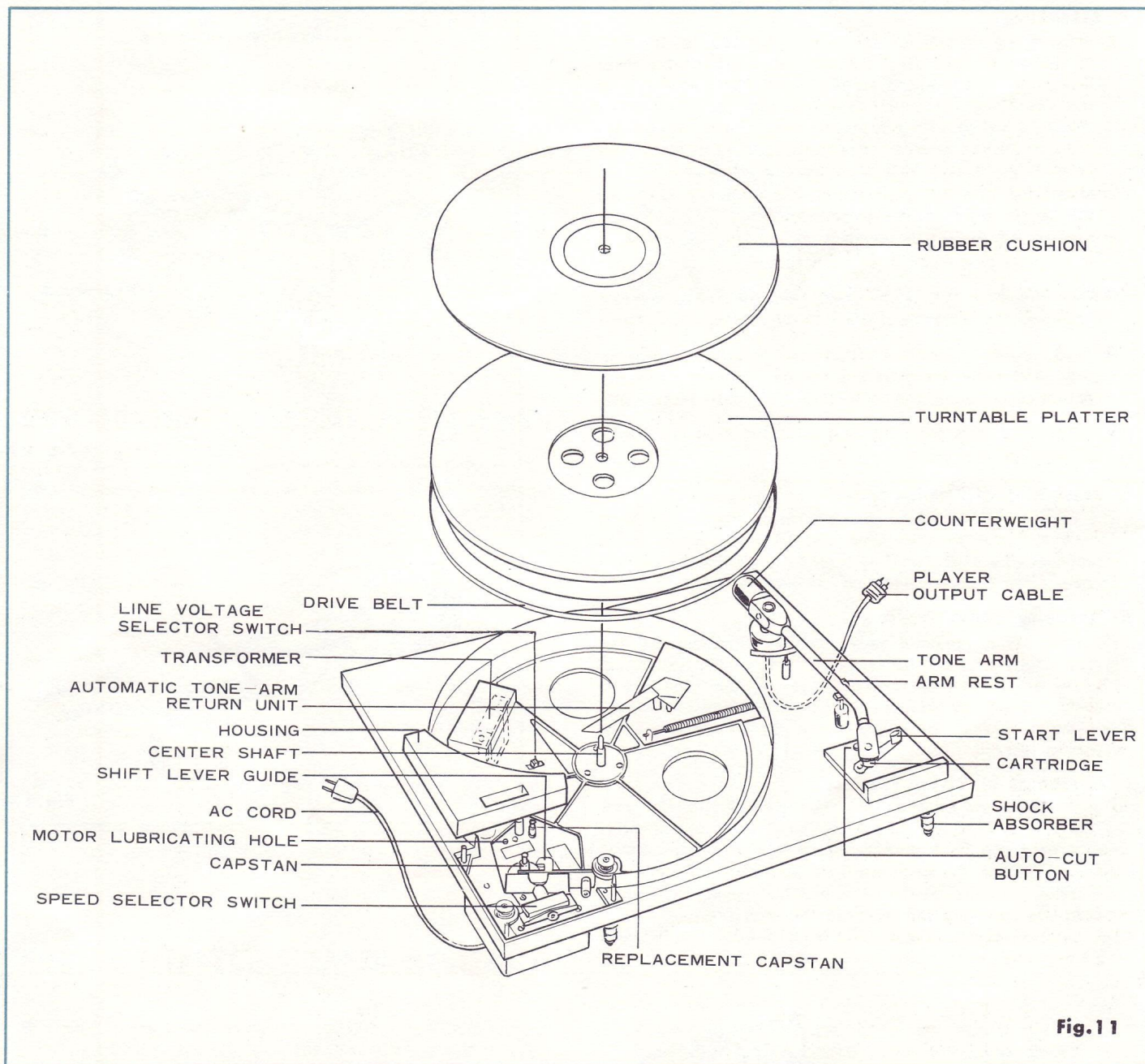

Fig. 11

## 4. Assembling

- 1) Remove the housing (or belt cover) located to the left of the player unit, lift it out vertically, and remove three lock screws (red-painted screws with fiber washers) in the vicinity of the motor assembly with the small screw driver furnished with the player unit. These screws are used to secure internal components during transit, thus protecting the unit against shock and vibration.
- 2) Mount the turntable platter and the rubber cushion on the center shaft in the order stated.
- 3) Stretch the drive belt installed around the periphery of the platter and place it on the capstan.

- While the drive belt is installed, keep the speed selector switch set to 33-rpm position (the left bottom position).
- The drive belt is provided with a tape. Pull the tape with fingers, and install the drive belt on the smallest capstan section as threading the belt thru the shift lever guide.
- Remove the tape from the belt after the tape is properly installed on the capstan.

## 5. Assembling of Pick-Up Arm

The counterweight for the pick-up arm of Model C-6000 is separately packed in order to prevent possible damage to the components by shock and vibration. Fig.13 illustrates how to mount the counterweight on the pick-up arm.

## 6. Measuring Stylus Pressure

Place the stylus pressure gauge on the turntable, let the stylus quietly rest on the graduated side of the gauge, adjust the stylus position on the gauge so that the stylus pressure completely balances the gauge in a horizontal position, and then read the indication on the gauge where the stylus is located.

## 7. Adjustment of Stylus Pressure

Loosen the screw securing the counterweight to the rear of the pick-up arm, and adjust the position of the counterweight back and forth until an optimum stylus pressure is obtained. Moving the counterweight backward will decrease the stylus pressure on the other end, and moving the weight toward the cartridge will increase the pressure. The optimum stylus pressure for Model C-6000 lies between 2.5-3.5 grams.

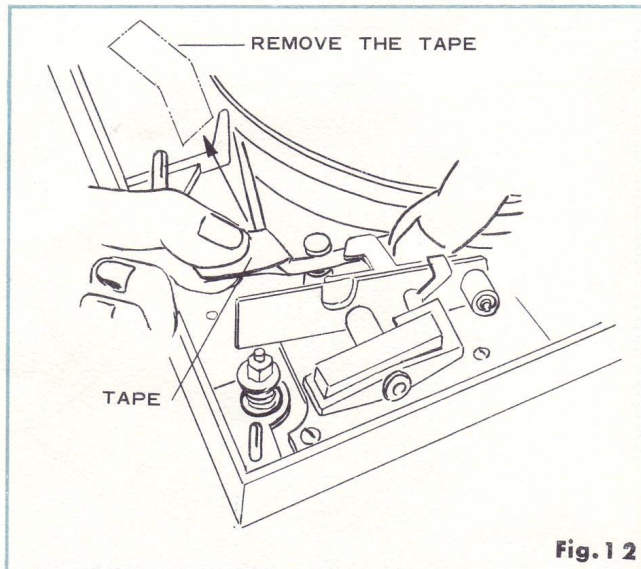

Fig. 12

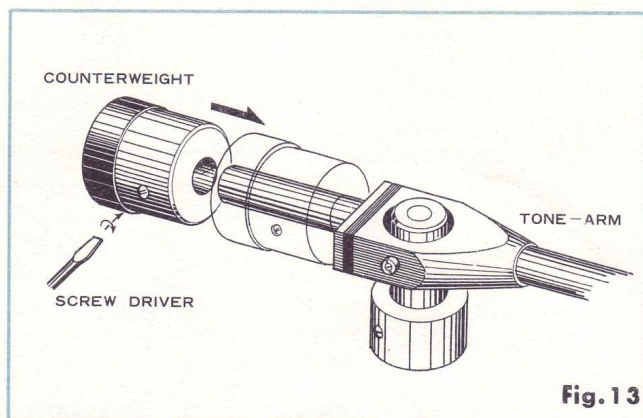

Fig. 13

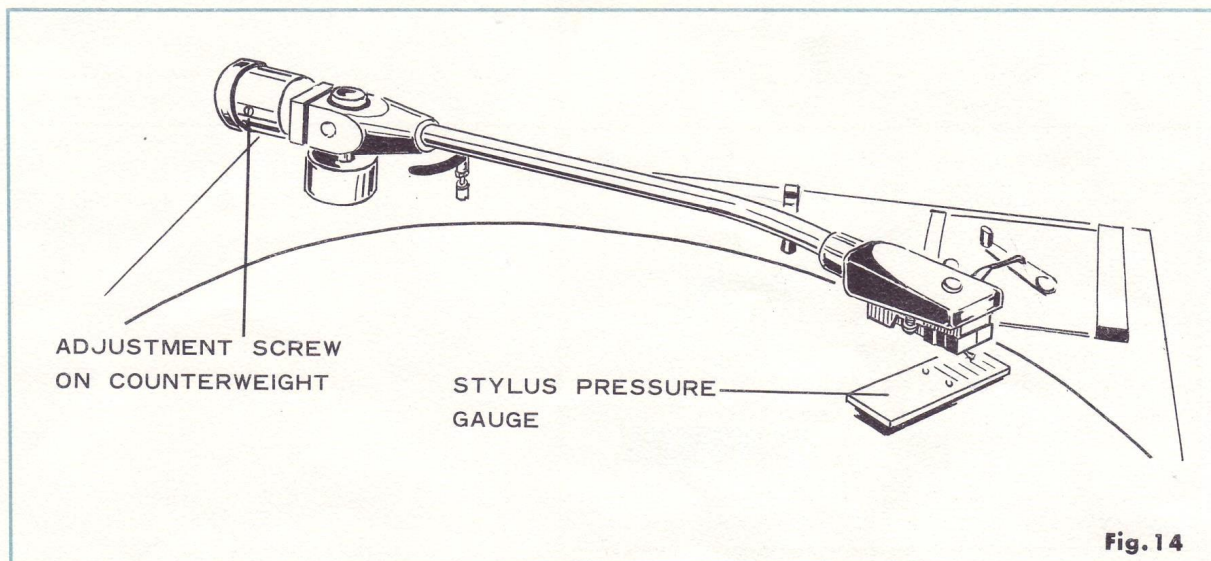

Fig. 14



## WHERE TO INSTALL MODEL C-6000

The best stereo-listening place is at the vertex (top) of an equilateral triangle having two stereo speakers at both ends of the base. From this, it is evident that the room corner or a narrow room is not an ideal location for installing stereo system. Remember that your Model C-6000 is fully transistorized, and avoid the following places for installation:

- The place where the influence of dust and humidity is significant, and where good ventilation is not obtainable.
- The place where the stereo system will be exposed on the direct sun ray.

- The place in the vicinity of heat-radiating apparatus (space heater, etc).

NOTE: In particular, transistors are weak against high temperature. Take good care to provide sufficient ventilation on the transistorized system.

- The place where the floor is not solid nor horizontal.
- If the place in which you like to install C-6000 has not much room in depth, remove the two rubber legs located on the front bottom of the cabinet and re-mount them at the spare holes located approximately 3-1/2" from the front of the cabinet.

## HOW TO INSTALL SPEAKER SYSTEMS

- All sides (except the rear side) of the speaker cabinet are equally finished. It may be thus recommended to set the cabinet with its long side down for shelf installation or with its short side down for floor installation.
- On the rear of the cabinet, hanger hardware are attached for use in wall installation of the speaker cabinet. Fix the cabinet on the wall vertically, using the hardware with nails furnished with the speaker cabinets.
- If you desire to install the speaker cabinet on the wall with its long side down, re-locate the hanger hardware to appropriate positions on the long side of the cabinet, and then fix the cabinet onto the wall with nails.
- It is possible to install stereo speaker systems on shelf or on the wall while keeping the C-6000 amplifier-player assembly nearby the listening place. Such installation may be best for enjoying music with the optimum stereo effect.

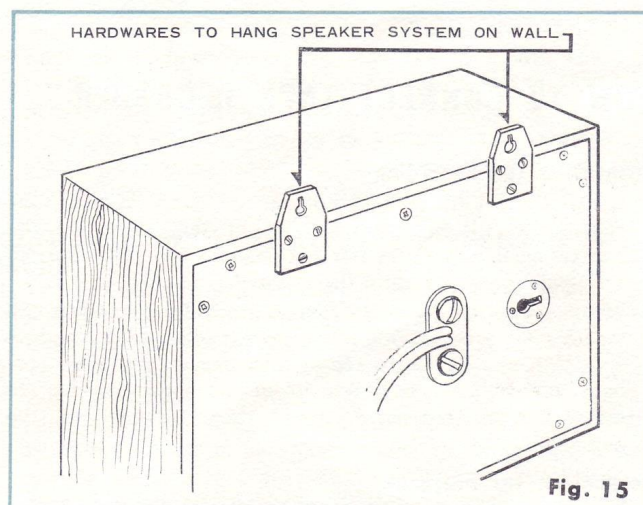

## HOW TO CONNECT SPEAKER SYSTEMS

- When you make necessary connections for speaker systems, antenna, ground, and tape recorder, observe the following precautions:

1. Remove two mounting screws on the rear of the amplifier, and take off the rear cover from the amplifier.
2. Insert the speaker cords (or antenna lead wires, etc.) thru the slot located in the bottom of the amplifier, and properly connect them to corresponding sockets (or terminals) as shown in Fig. 16. Do not use the holes in the rear cover for inserting cords and lead wires, because the rear cover can not be replaced back on the amplifier.

- How to connect speaker systems

1. Two stereo speaker systems of C-6000 are completely identical, and there is no difference between them. For convenience of description, we tentatively designate the speaker system located on the left hand side of Model C-6000 as the L (left) channel speaker and the one on the right hand side as the R (right) channel speaker.

2. Connect the left speaker terminal (18) to the plug on the speaker cord coming from the L channel speaker.
3. Connect the right speaker terminal (17) to the R channel speaker in the similar manner as above.

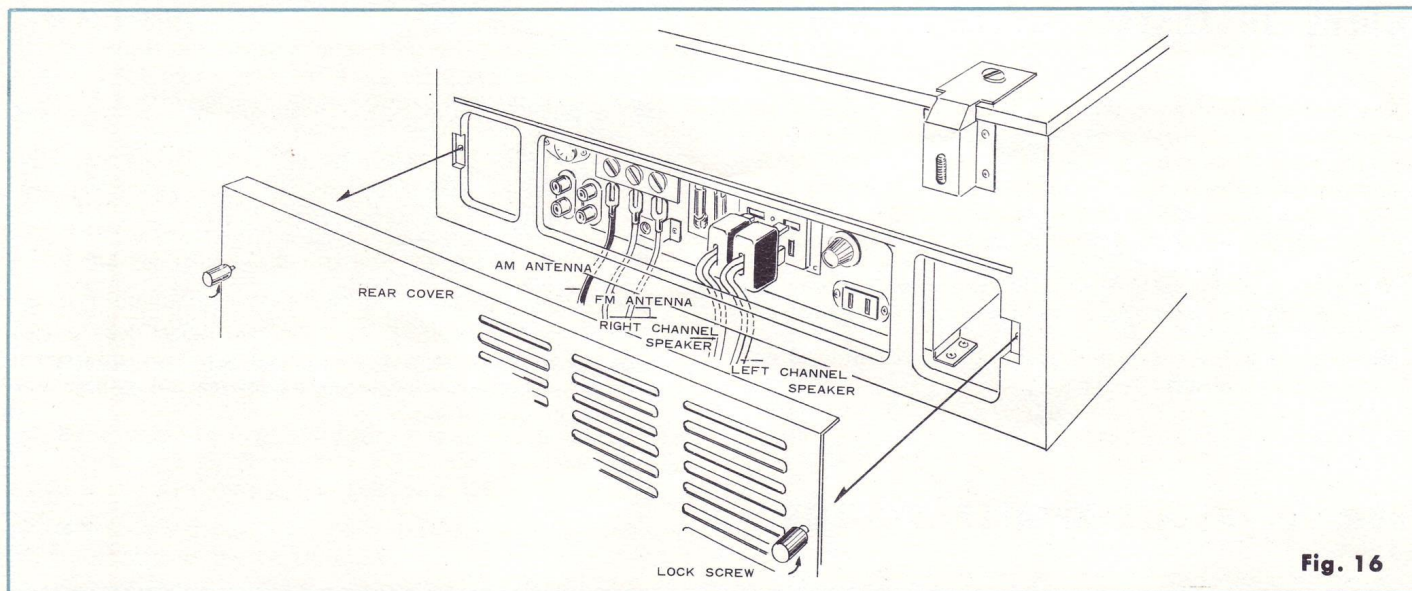

Fig. 16

## HOW TO CONNECT TAPE RECORDER

### Connection for Recording

1. Connect the LINE INPUT terminal of your stereo tape recorder to the REC terminal (22) of this amplifier; the top terminal is for the left (L) channel and the bottom terminal is for the right (R) channel.
2. When a monoral tape recorder is used for recording the music played on C-6000, first select the tape channel on which you desire to record the music, and then connect the channel input terminal of the tape recorder to either the top terminal or the bottom terminal of the amplifier.

### Connection for Playback

1. Connect the LINE OUTPUT terminal of your stereo tape

recorder to the AUX terminal (21) of the amplifier. The top terminal is for the left (L) channel and the bottom terminal is for the right (R) channel.

2. When a monoral tape recorder is used to feed signals to the C-6000, connect the tape recorder output terminal to the top terminal (for the left channel) of the amplifier.

### RECORD/PLAY-BACK CONNECTOR SOCKET (DIN TYPE)

If your tape recorder is provided with a DIN-Type Record/Play-back connector plug, simply connecting the plug to the TAPE REC/P. B. CONNECTOR socket will permit you to complete connections for both recording and play-back with the tape recorder.

## HOW TO CONNECT ANTENNA AND GROUND

### ● AM (Medium Wave) Antenna

1. If your house is made of wooden material and located close to the broadcasting station, lay the furnished AM antenna wire along the wall in your room and connect one end of the wire to the AM antenna terminal (14).
2. If your house is made of ferro-concrete or located at a distant place from the broadcasting station, install a separate AM antenna outdoors for reception of AM radio waves and connect it to the AM of the amplifier.

### ● FM Antenna

1. If your house is built with wooden material or located near the broadcasting station, use the furnished T-indoor antenna.  
Establish the horizontal section of the T-antenna perpendicular to the direction in which the FM broadcasting station is located, and connect the end of the T-antenna vertical section to the FM antenna terminal (15).

2. If your house is of ferro-concrete or far from the FM broadcasting station (such location results in weak signal and large noise), install a separate FM antenna outdoors for reception of FM radio waves.

There are a variety of FM antennas commercially available, ranging from three-element type to seven-element type. Selection of the antenna type varies with the area you are in; consult the service man at the shop where you purchase antenna.

### ● Grounding

The GROUND terminal (24) is used to ground your amplifier. Connect the ground wire coming from a well-established ground electrode.

NOTE: For making a bundle of hook-up wires such as cords and leads, use the furnished cable-ties.



## HOW-TO OPERATE

### Operation for Listening to AM or FM Program

#### AM Program

1. Set the SELECTOR switch (7) to AM.
2. Select the desired station with the TUNING control (4), while watching the TUNING INDICATOR (2).

#### FM Stereo/Mono Program

1. Set the SELECTOR switch (7) to FM AUTO.
  - Your Model C-6000 is provided with automatic FM stereo/mono switching circuit. When you listen to an FM program, set the SELECTOR switch (7) always to FM AUTO position. However, in case that arriving FM signal is weak and extraneous noise is large, or that you desire to listen to an FM stereo program in mono-mode for some reasons, you may set the SELECTOR switch to FM MONO position.
2. Set the AFC switch (10) to OFF
3. Select the station you desire with the TUNING control (4) while watching the TUNING INDICATOR (2). Whenever an FM stereo program is received, the FM STEREO indicator flashes on, permitting you to listen to the program in stereo mode.
4. After a station is selected properly, immediately set the AFC switch (10) to ON position.

#### Operation for Playing Record

The record player of Model C-6000 is featured with an automatic tone-arm return mechanism and a belt-driven system. For operation of the record player, observe the following procedures:

#### Record Playing:

1. Set the SELECTOR switch (7) to PHONO.
2. Check and see if the rated RPM speed of the record agrees with the speed setting (either 33-1/3 rpm or 45 rpm) on the player unit. If the setting does not agree with the requested speed of the record, pull the arm-elevation lever toward you, while keeping the tone-arm on the arm rest. Then, the turntable will start rotating. With the turntable in motion, set the speed selector

switch on the player unit to the rated speed of the record you are about to play. The selector switch is marked with two record speeds (33-1/3 rpm or 45 rpm), one on each end.

When one end of the switch is depressed with the finger, the speed marked on the depressed end indicates the running speed of the turntable. After the speed is properly adjusted, lightly depress the Auto-Cut button to stop the turntable.

NOTE: During changing the speed, the motor and turntable must be rotated. If the speed is changed while the turntable is not in motion, the drive belt may be damaged.

3. Bring the tone-arm over the record and set the stylus above the starting groove on the record. For smooth operation, it may be recommendable to move the tone arm toward the center of turntable, passing over the starting groove, and then bring back the arm above the starting groove.
4. Pull the arm elevation lever fully toward you. The turntable will then start rotating, and the tone arm will be quietly lowered to cause the stylus to fit in the starting groove. The music now begins.
5. After the record-play comes to an end, the automatic return mechanism automatically returns the tone arm to the arm rest and shuts off power for the player unit.

#### Operation to Stop or Start Playing in the Middle of Record

1. To start playing in the middle of the record, bring the tone arm above the groove where to start playing and then pull the arm elevation lever toward you.
2. To stop playing in the middle of the record, press the Auto-Cut button. The tone arm will be then automatically returned to the arm rest, and the power for motor will be turned off. It is also permissible to bring the tone arm to the arm rest manually. In this case, it is necessary to press the Auto-Cut button separately to turn power off, because the motor is kept running.

## TIPS FOR PROLONGED OPERATION OF RECORD PLAYER

- To start playing, always pull the arm elevation lever fully toward you.
- When you use the Auto-Cut button, lightly press it and immediately let go your hold.
- Do not change the turntable speed by rotating the turntable by hand. This will shorten the life of the drive belt.
- Do not touch the tone arm while it is returning to the arm rest.
- Lubricate the following locations occasionally. Use the furnished oil (or good machine oil) for lubrication.
 

Motor Lubrication Hole	.....Once in three months, one or two drops.
Shaft of Turntable	.....Once or twice in a year, five or six drops.
Automatic Return Mechanism	.....Once in a year, one or two drops.

NOTE: Be sure that no oil adheres to the drive belt. The oil adhered onto the belt may cause slippage in driving, resulting in wow and flutter. In such case, obtain carbon-tet. or the equivalent solvent from the pharmacy and clean the belt with the solvent.

#### Stylus Replacement

- The stylus should be replaced before it is completely worn out. Diamond stylus is used with Model C-6000. The rated life of diamond stylus is approximately from 200 to 300 hours (equivalent to playing 200 records of 12" LP disc).
- To replace the stylus, remove the old stylus and insert a new one into the cartridge so that the stylus holder is set securely into the cartridge receptacle. The stylus is normally obtained in the state shown in the diagram circled in dotted line. Contact to the PIONEER sales agent

nearest to where you are and obtain the PIONEER PN-10 that best suits to Model C-6000.

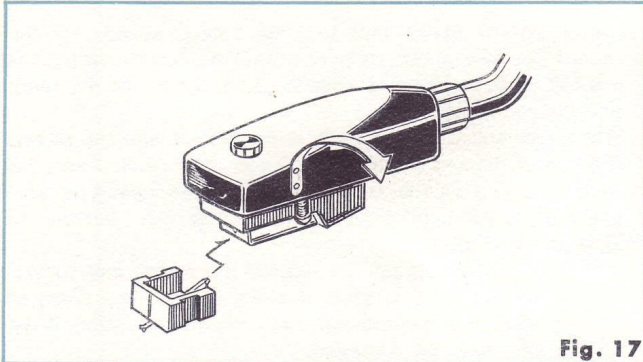

## MODEL C-6000 TECHNICAL SPECIFICATIONS

### Transistors and Diodes

2SB 347 (or 2SB 348)	2 (Equalizer amp)
2SB 345	2 ( " )
2SB 346	6 (Control amp, Driver)
2SB 77	1 (Ripple filter)
2SB 77A	3 (Driver, Ripple filter)
2SD 77A	2 (Driver)
2SB 449	4 (Power amp)
2SA 420	1 (FM-FRONT-END)
2SA 44Q	2 ( " )
2SB 54	3 (Switching unit)
2SA 342	4 (FM IF Unit)
2SC 183	3 (MPX Stage)
2SC 458	1 (MPX indicator Switch)
2SA 102	1 (AM Converter)
2SA 101	2 (AM IF amp)
<b>Diodes</b>	
SE 0501 (or SD-IY)	2 (Rectifier)
SE 0502 (or SD-IZ)	2 ( " )
IN 60	14 (FM Det, auto select circuit, AGC, Meter circuit. MPX 19kc doubler, switching AM Det AGC Meter circuit)
1S 86 (or 1S 553)	(FM AFC)
RD 11A	(Constant Voltage)

### Audio Section

Circuitry	Single Ended push-pull circuit without output transformer
Music Power Output	34 watts total (EIA)
BMS Rated Power Output	11 watts per channel
Harmonic Distortion	Less than 1% (at 1kHz rated output)
Frequency Response	± 3db, from 50Hz to 20kHz (Over-all)
Hum & Noise (at rated output)	MAG: better than 65db AUX: better than 75db
Inputs and Audio Sensitivity	MAGnetic PHONO: 2.2mv. AUXiliary: 165mv.
Output Terminals and Jacks	Speakers: 8 tr 16 ohms, Stereo

headphones, jack Simultaneous tape Recording jack, equipped with TAPE MONITOR switch. Tape recording/playback jack (DIN standards)  
PHONO: RIAA  
BASS: Switchable to ON-OFF

Equalization Curves  
Tone Controls  
(each channel)  
Loudness Countour

### FM Section

Circuitry	3 gang variable capacitor for Tuned RF stage and separate type converter front-end with AFC circuit Wide-band radio discriminator
Frequency Range	87 ~ 108MHz
IHF Usable	3.5 $\mu$ v
Sensitivity	
Image Rejection	52db (at 98MHz)
Signal to Noise Ratio	55db (100% MOD)
Antenna Input	300 ohms (balanced)

### Multiplex Section

Circuitry	Time-switching type de-modulator FM Mono Stereo Automatic section
Channel Separation	35db (at 1 kHz)

### AM Section

Frequency Range	525 ~ 1605kHz
IHF Usable	28 $\mu$ v
Sensitivity	
Image Rejection	33db (at 1000 kHz)

### Power Supply, Etc.

Power Supply	Full-wave rectifier using silicon diodes
Line Requirements	115 / 230 volts, 0.65 / 0.33 amp. (switchable), 50 ~ 60 Hz 64 watts (Max)

### Amplifier-Player Cabinet Section

Dimensions	8 $\frac{3}{8}$ " (H) $\times$ 20 $\frac{1}{2}$ " (W) $\times$ 20 $\frac{1}{2}$ " (D)
Weight	49 lbs. 5oz. (Include player and Receiver)

### Speaker Systems Section

Type	Two-way system
Mounted Speakers	8" Woofer, horn type tweeter
Impedance	8 Ohms
Frequency Response	40 to 20,000 Hz
Dimensions	21 $\frac{1}{4}$ " (H) $\times$ 11" (W) $\times$ 7 $\frac{7}{8}$ " (D)
Weight	16 lbs. 5oz

### Record Player Section

Type	Belt-Driven system With built in 12" turntable platter
Cartridge (Model PC-10)	Moving magnet type (Replacement stylus model PN-10)
Optimum stylus force	2.5 to 3.5gr
Frequency Response	20 to 20,000 Hz
Pickup Arm	Statically balanced type pipe arm
Phono Motor	Four-poles synchronous motor (33 $\frac{1}{3}$ , 45 RPM)
Wow	Less than 0.15%
Power Requirement	17 watts



## Maintenance of Cabinet

Hard-rubbing the cabinet surfaces with the furnished cabinet wax once in every three or four months will preserve the deluxe cabinet finish over extended periods of time.

1. Put some wax on clean, dry cloth, and coat the wax over the cabinet surfaces equally.

2. Wipe off the extra wax with another piece of dry cloth and rub the cabinet surfaces with it along wood grain.  
NOTE: Firmly close the lid on the wax can and keep it at a cold and dark place for storage. Be sure that the wax is not placed close to fire, because the wax is inflammable.  
Wax on hands can be easily washed off with water.

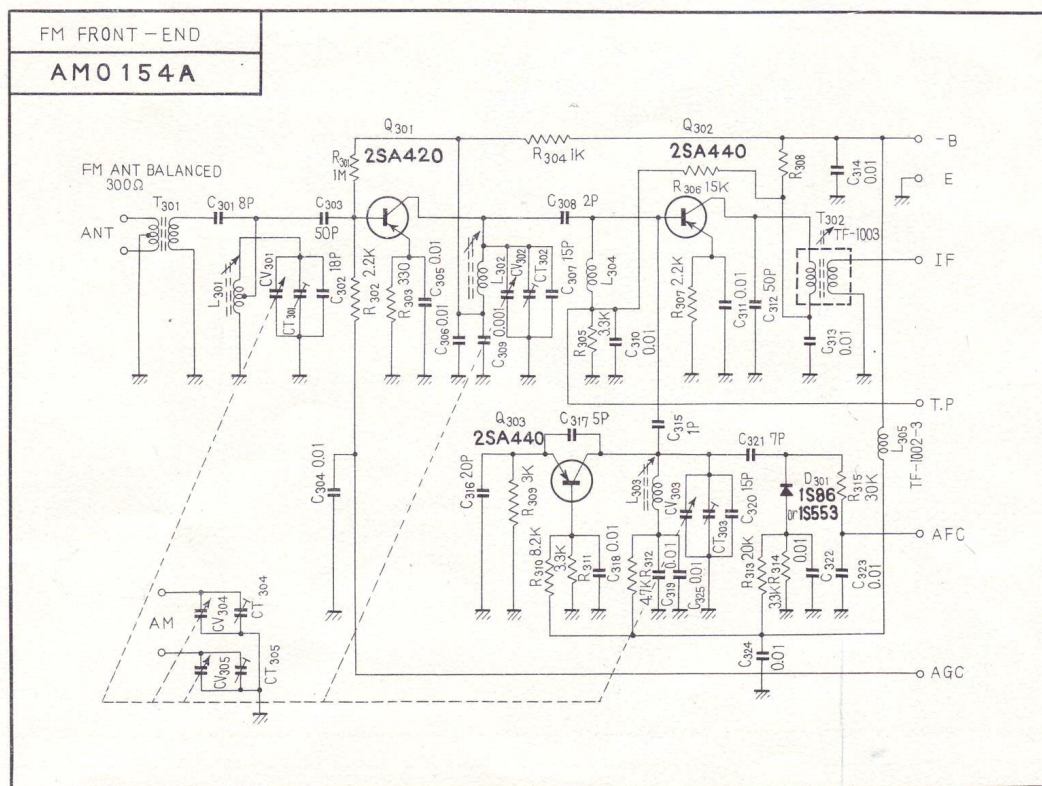
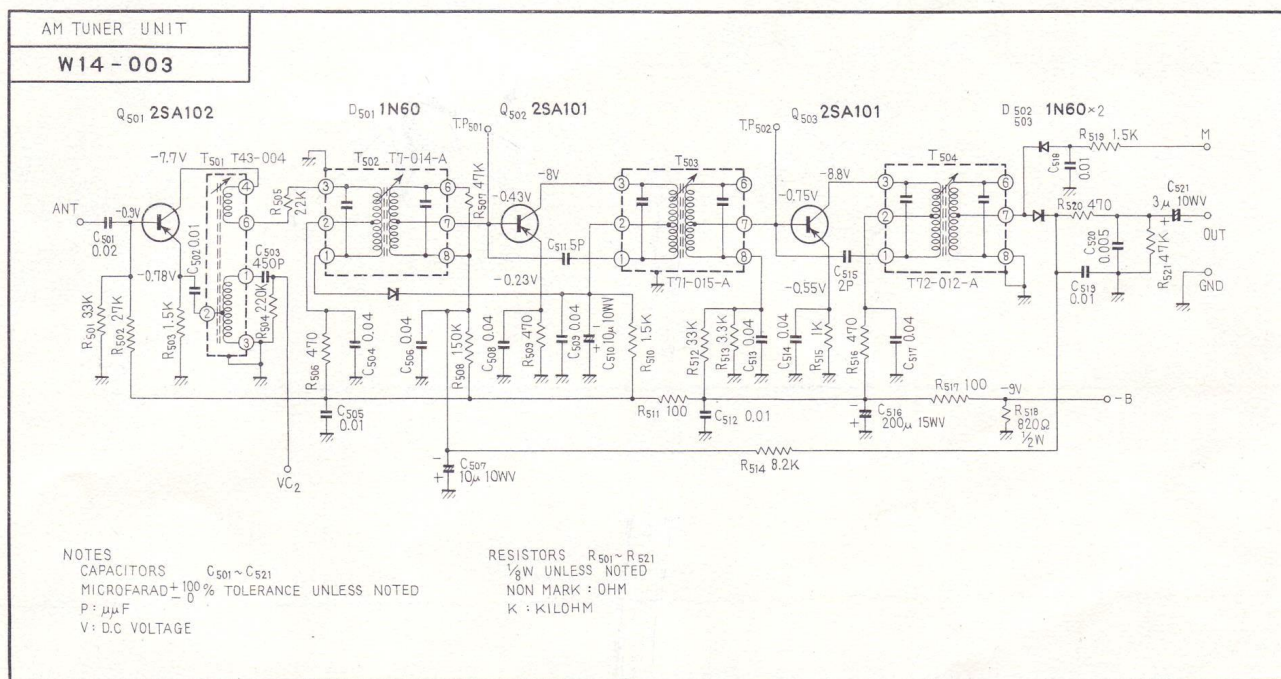

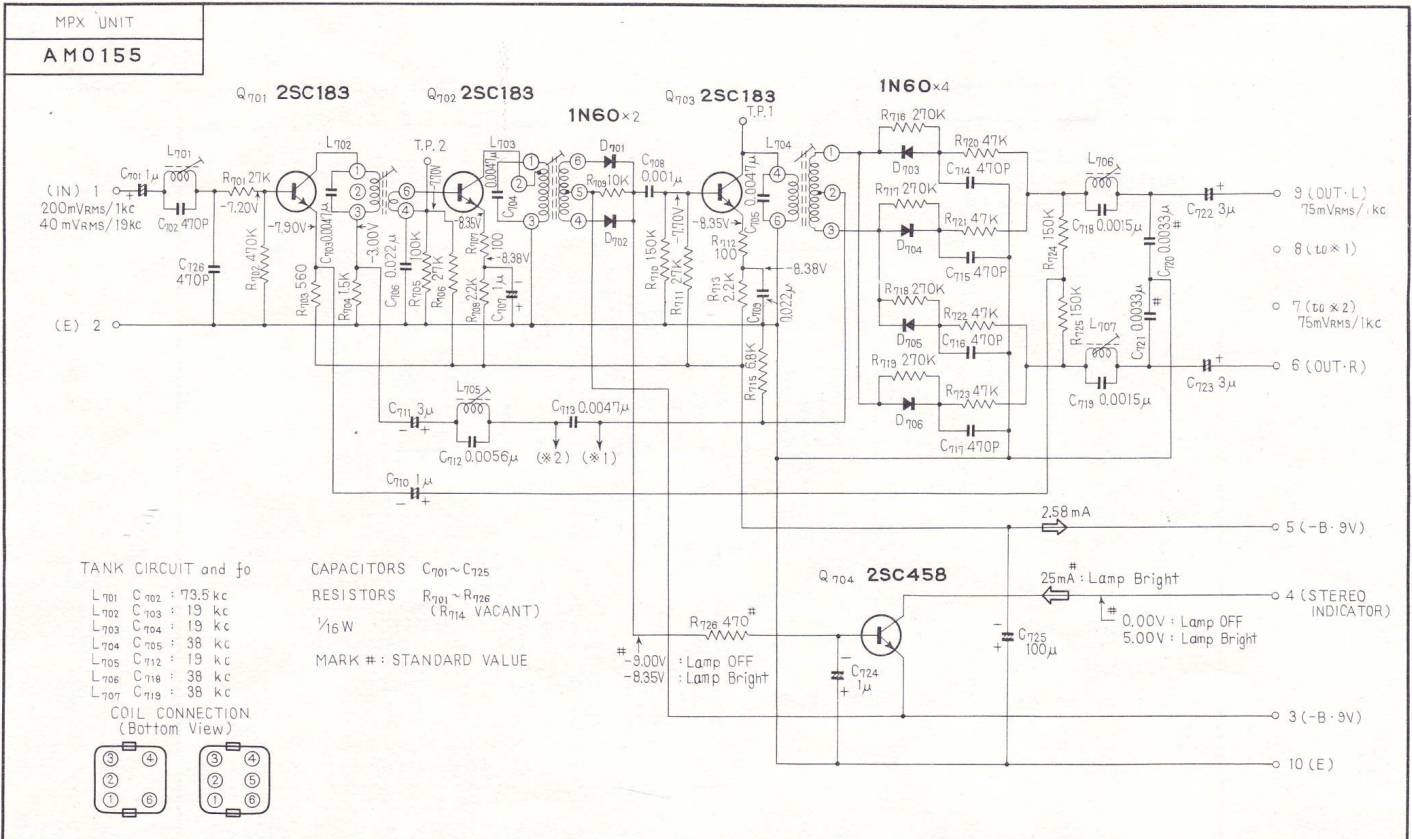
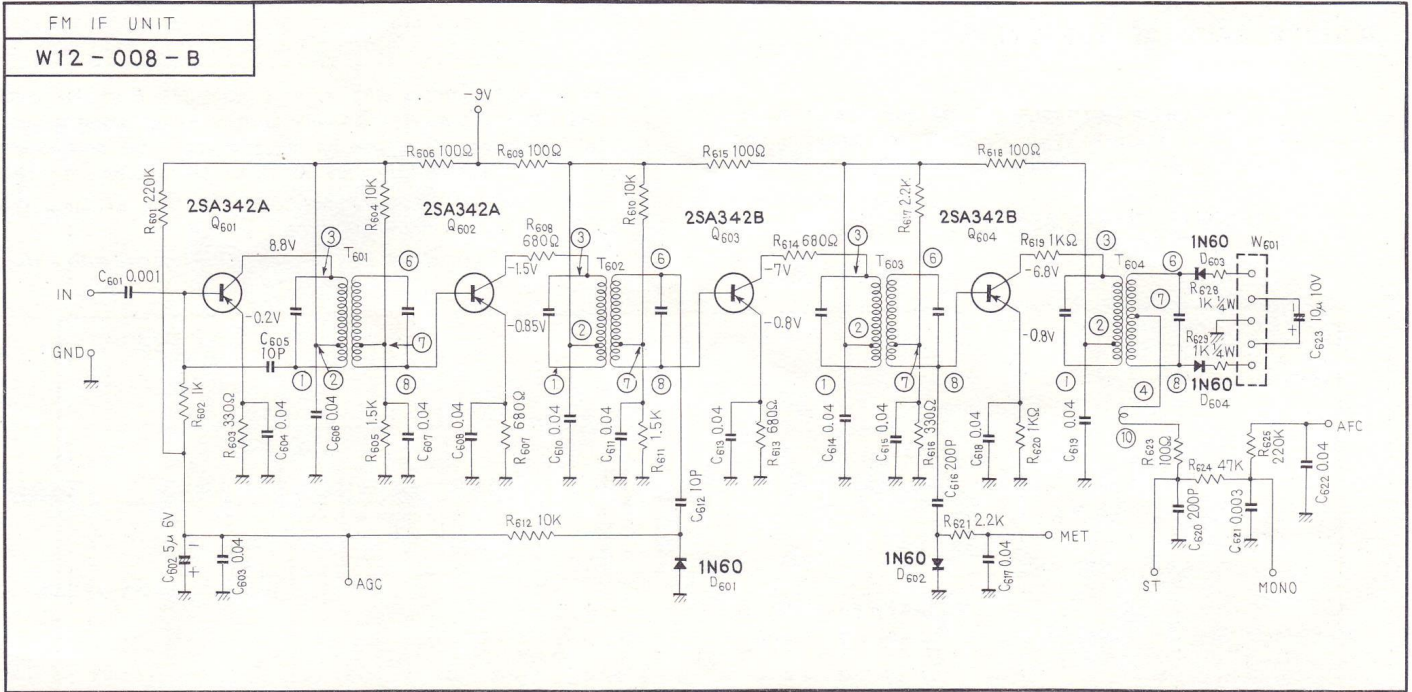



W14-003

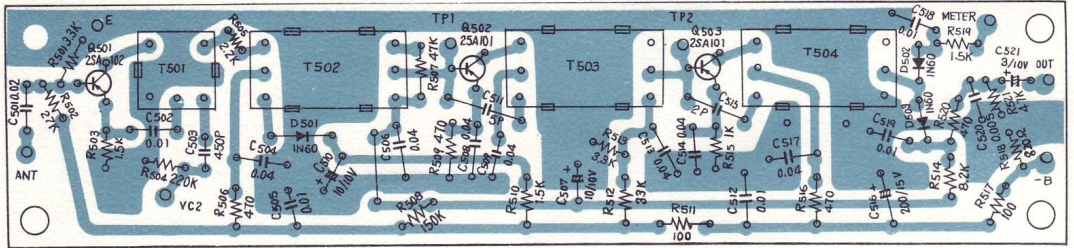

W12-008

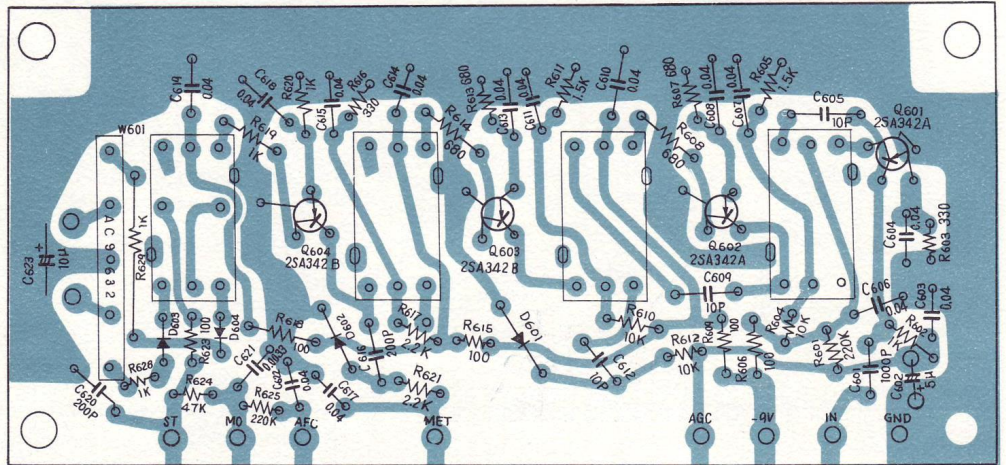

AM0155

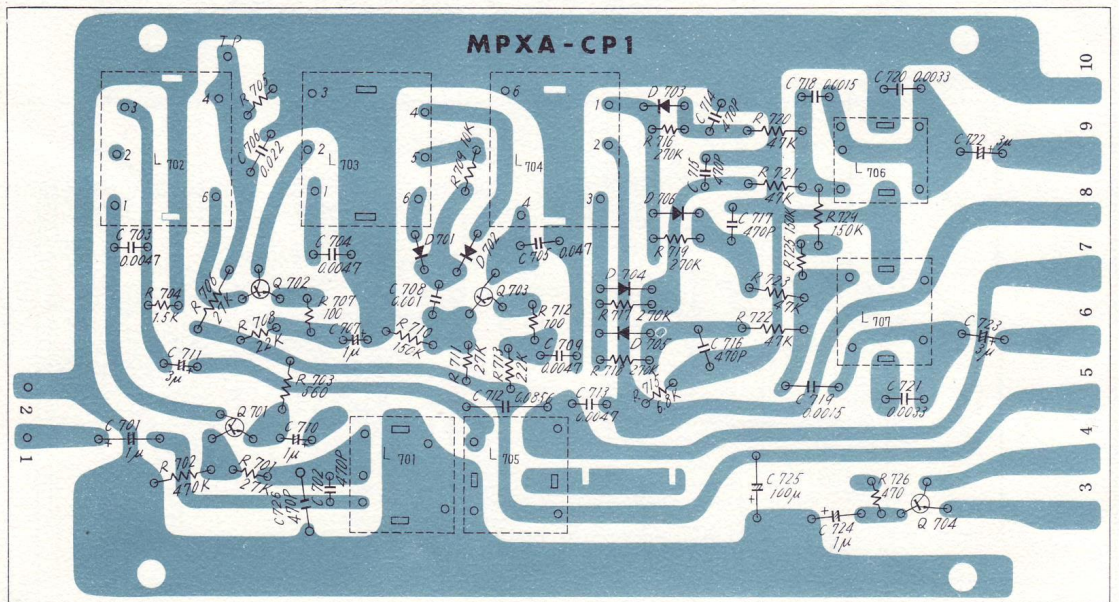

## DIAL CORD STRINGING

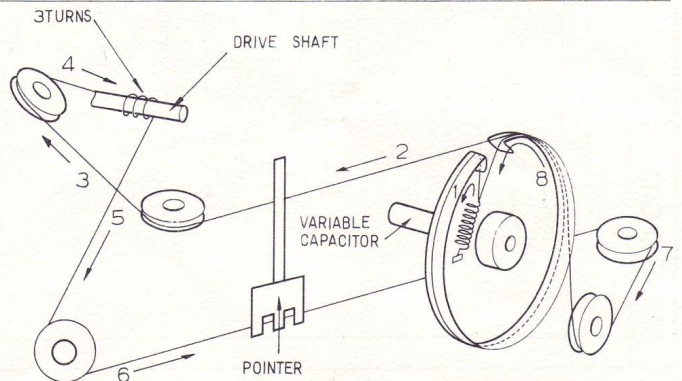



## ALIGNMENT OF THE C-6000

### Alignment of AM Section

STEPS	Input				Dial Setting	Equipment Coupling	Alignment	
	Generator	Coupling	Freq.	Mod.			Adjst	Remarks
1	Sweep Generator	TP2	455 kHz 80dB	400Hz 30%	Point of no interference as near as 530kHz	Oscilloscope OUT	T <sub>504</sub>	Adjust to get maximum sensitivity and symmetry
2	"	TP1	50dB	"	"	"	T <sub>503</sub> T <sub>504</sub>	"
3	"	ANT terminal of AM unit	40dB	"	"	"	T <sub>502</sub> T <sub>503</sub> T <sub>504</sub>	"
4	Signal Generator	Antenna terminal	600kHz 70dB	"	600kHz	Oscilloscope VTVM OUT	T <sub>501</sub>	Adjust to get maximum deflection
5	"	"	1400kHz 70dB	"	1400kHz	"	TC <sub>305</sub>	"
6	Repeat STEPS 4 and 5 several times							
7	"	"	600kHz 40dB	"	600kHz	"	Bar Antenna	" (Adjusting Ring)
8	"	"	1400kHz 40dB	"	1400kHz	"	TC <sub>304</sub>	"
9	Repeat STEPS 7 and 8 several times							

### Alignment of FM MPX Section

Position of Switch: SELECTOR.....FM AUTO AFC.....OFF  
 Volume Control Setting: Fully Counterclockwise  
 Input Signal: Main(L+R) 40.5 kHz deviation (60%), 19kc pilot 7.5kc deviation(10%)

STEPS	Circuit to be adjusted	Input		Connect VTVM	Alignment		
		Coupling	Signal		Adjust	Remarks	
1	SCA Filter	Oscillator to IN	73.5kHz 40mV	AC VTVM OUT(L or R)	L <sub>701</sub>	Adjust to get minimum deflection	
2	19kHz & 38kHz Trap	MPX Generator to FM Antenna terminal	19kHz	" OUT(L and R)	L <sub>705</sub> L <sub>706</sub> L <sub>707</sub>	Adjust to get minimum deflection	
3	19kHz stage	"	"	"	L <sub>702</sub> L <sub>703</sub>	Adjust to get maximum brightness	
4	38kHz Stage	"	L-R	" OUT(L or R)	L <sub>704</sub>	Position of Separation control: Full clockwise, Adjust to get maximum deflection	
5	Separation Control	"	L or R	"	VR <sub>4</sub> (Separation Control)	Adjust to get minimum deflection of reverse channel	
6	Repeat STEPS 4 and 5 two times. Confirm if R and L signals come from each output terminals.						



### Alignment of FM Section

Disconnect IF terminal of Frontend unit from IN terminal of IF unit  
 Position of Switch: SELECTOR.....FM MONO AFC.....OFF  
 Volume Control Setting: Fully Counterclockwise

STEPS	Input		Dial Setting	Output		Alignment	
	Equipment Coupling	Freq.		Level	Equipment & Coupling	Adjust	Remarks
1	Sweep Generator IN	10.7MHz	50dB		Oscilloscope MET	T <sub>601</sub> T <sub>602</sub> T <sub>603</sub>	Adjust to get maximum sensitivity and symmetry
2	" "	"	80dB		" "		Check symmetry of Curve
3	Remove electrolytic capacitor C <sub>623</sub> (10 $\mu$ F) in detector circuit						
4	" "	"	40dB		Oscilloscope MONO	T <sub>604</sub>	Adjust primary stage of T <sub>203</sub> so that incline of straight part of "S" curve will be steepest adjust secondary stage so that center of "S" curve will coincide with center of marker
5	Connect IF terminal of Frontend unit to IN terminal of IF unit						
	" TP of Frontend	"	50dB	Point of no interference as near as 88MHz	" MET	T <sub>302</sub> T <sub>601</sub> T <sub>602</sub> T <sub>603</sub>	Adjust to get maximum sensitivity and symmetry
7	" "	"	80dB	"	" "		Check symmetry of curve
8	" "	"	40dB	"	" MONO	T <sub>604</sub>	Adjust similarly STEPS 4
9	Connect electrolytic capacitor C <sub>623</sub> (10 $\mu$ F)						
10	Signal Generator FM Antenna terminal	90MHz	20dB (400Hz 30%)	90MHz	Oscilloscope VTVM MONO	L <sub>303</sub> (L <sub>0</sub> )	Adjust to get maximum deflection
11	" "	106MHz	" "	106MHz	" "	CT <sub>301</sub> (H <sub>0</sub> )	"
12	Repeat STEPS 10 and 11 several times						
13	" "	90MHz	" "	90MHz	" "	L <sub>301</sub> (L <sub>A</sub> ) L <sub>302</sub> (L <sub>R</sub> )	"
14	" "	106MHz	" "	106MHz	" "	TC <sub>301</sub> (H <sub>A</sub> ) TC <sub>302</sub> (H <sub>R</sub> )	"
15	Repeat STEPS 13 and 14 several times						

# PIONEER



## **PIONEER ELECTRONIC CORPORATION**

15-5, 4-Chome, Ohmori-nishi, Ohta-ku, Tokyo, Japan

**PIONEER ELECTRONICS U.S.A. CORPORATION**

140 Smith St., Farmingdale, N.Y. 11735, U.S.A.

**PIONEER ELECTRONIC EUROPE AG.**

59, Forch Strasse, 8032, Zurich, Switzerland