

HI-FI COMPONENTS





Pioneer hi-fi components — for better audio/video integration and better digital sound

Surround sound, stereo TV, hi-fi and digital video sound, big screens and higher-resolution CRTs — these are the reasons why you should consider mating dynamic pictures with dynamic sound. And Pioneer provides the perfect means. Our new receivers are ready to help you take advantage of the recent advancements made in audio and video: they feature surround sound processors (a professional Dolby Pro-Logic Surround decoder in our best model), a number of connections for video components, and even an amp for surround channels.

In our CD players, we combine still better sound with easier operation. Designed to fight resonance and vibration for clear digital sound, our players come with features such as 8-times oversampling digital filters and twin D/A converters to provide superb reproduction. The "Music Window," time fade edit, one-touch digital fade, multi-play CD format, and Magazine Program Selection System are just some of the extras that have made CD operation more convenient than ever.

Improvements like these are also made in our new amps, tuners, cassette decks and speaker systems — all to allow you to enjoy the extraordinary dynamic range of digital sound.

Pioneer — taking the lead into the future of audio and video.

STATION 30 ch FM 100.50 MHz

DOLBY SURROUND PRO LOGIC

AUTO TUNED STEREO TONE ACUSTIC

TV VIDEO ADAPTOR PHONO

© beim Hersteller Archiv Michael Otto HiFi-Classic.de

PRESET LEVEL BALANCE L R MUTING

MASTER VOLUME

FM AM TUNING MEMORY SCAN HITS

*1 *2 *3 *4 *5 *6 *7 *8 *9 STATION CALL *10 *11-20 *21-30 *31-40 *41-50 *51-60 *61-70 *71-80 *81-90 *91-100

MEMORY STATION NAME

TUNING

AUDIO/VIDEO RECEIVERS

A/V remote controls — some programmable

All receivers in our "VSX" series come equipped with a full-function audio/video remote control. It lets you operate not just the receiver it comes with, but also other audio components and even video equipment that feature our SR (System Remote) logomark.  What's even more amazing, the remote units for the VSX-9300S and VSX-3300S are "Smart Remote"™ that can "learn" functions of most other infrared remotes.

Versatile video connection

Our "VSX" receivers are fully capable of connecting and controlling video equipment as well.

VSX-9300S/VSX-7300: Each connects four video program sources. Dubbing is possible from disc to tape or tape to tape. Using the VCR-1 record selector, you can even watch an entirely different video program during dubbing. Both receivers permit connection of a video adaptor and two monitor TVs.

VSX-5300: Connects three video program sources. Dubbing is possible, and two monitor TVs can also be connected.

VSX-3300/VSX-3300S: Each connects a VCR and an LD player. Dubbing is possible from VDP to VCR. Again, a monitor TV can also be connected.

In addition, each receiver is provided with a 5-pin DIN socket that accepts an optional RF modulator (JA-RF5) for connecting a regular TV without video inputs.

Movie-theater surround sound

Ever wished to have that theater sound at home when you view videos? Now you can do just that because many video tapes and discs transferred from films made since the mid-1970's now contain Dolby* Surround in the soundtrack. All it takes to enjoy this realistic movie-theater sound is to add a proper decoder and speakers to your audio/video system. The good news is that every Pioneer "VSX" receiver is equipped with surround sound capabilities.

● Dolby Pro-Logic Surround (VSX-9300S)

The Dolby Surround decoder in the VSX-9300S is special: it's the Dolby Pro-Logic Surround, the same kind of processors used by most first-run movie theaters. It decodes encoded sound information contained in Dolby Surround video software and produces five distinct outputs (left front, right front, left rear, right rear and center front) to put you in the middle of the action.

The Dolby Pro-Logic features active matrixing and steering logic, to reduce crosstalk and improve separation between adjacent channels to better than 25dB, thus making stable imaging possible. Moreover, steering logic enhances the sense of

Sound Field Comparison

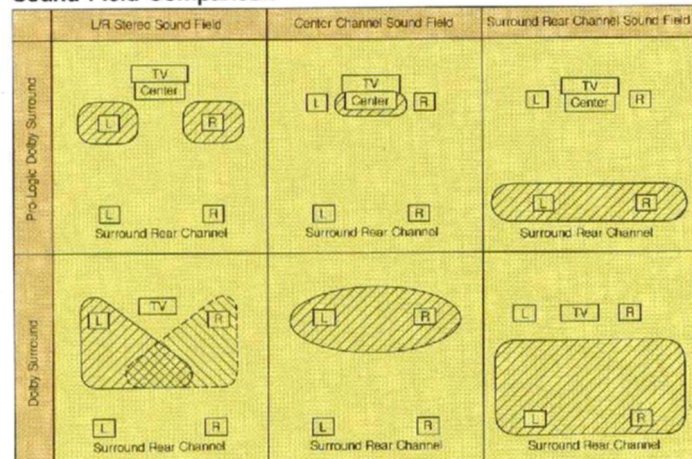

Note: An additional monaural amplifier is required to drive the center speaker.

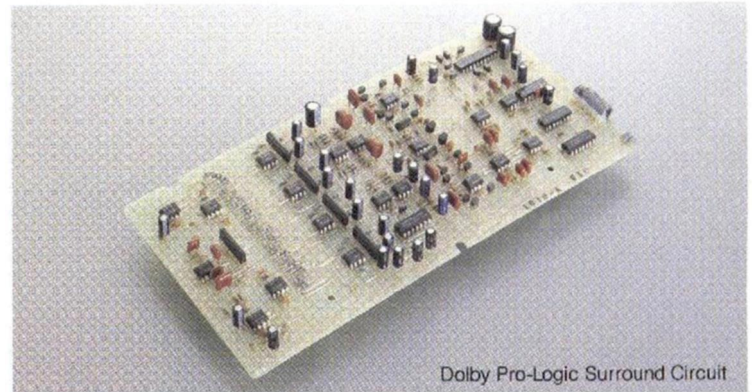

direction by emphasizing the dominant channel and suppressing other less dominant channels. Three center channel output modes — NORMAL, WIDE and PHANTOM — are available for your choice.

Our Pro-Logic Surround decoder utilizes an advanced digital delay. Since the delay for surround is synthesized digitally, both noise and distortion are kept to a minimum.

● Dolby Surround (VSX-7300/5300)

The VSX-7300 and VSX-5300 feature a Dolby Surround decoder based on digital technology. You can adjust delay time to 15, 20 or 30 milliseconds, depending on the size of your "media" room.

● Stadium and Simulated Surround (VSX-9300S/7300/5300)

Our surround decoder offers two more options. Stadium Surround provides the open, reverberant ambience of outdoor concerts and sports events. And Simulated Surround recreates the ambience of a live space, like a disco or concert hall: you hear direct sound from the front, and reverberations and echoes from behind.

● Speaker Matrix Surround (VSX-3300/3300S/SX-2300)

Video signal selector (VSX-9300S/7300/5300/3300/3300S)

When you watch a video, you can use the convenient video signal selector to choose the video that matches the audio program of your choice. It's a convenience that comes in handy when recording a simulcast — FM for audio, cable TV for video — or adding personal touches to your video productions.

Simulated Stereo (VSX-9300S/7300/5300/3300/3300S/SX-2300)

All our receivers except for the SX-1300 are equipped with Simulated Stereo that lets you enjoy fuller sound from video software with mono soundtracks.

Split-screen video enhancer (VSX-9300S/7300/5300)

While you view or dub videos, our video enhancer lets you make edges in the picture sharper and clearer. The split-screen control lets you compare the processed and unprocessed picture on the same screen. Conveniently, the VSX-9300S and VSX-7300's enhancer lets you enhance the video signal going to the VCR (VCR-1) without affecting the signal you watch.



VCR noise filter (VSX-9300S/7300/5300)

The VCR noise filter reduces noise in VCR's sound so that you can enjoy cleaner soundtracks.

Acoustic memory (VSX-9300S/7300/5300)

You can create five customized response curves using bass and treble controls, and commit them to the computer memory for instant recall at the touch of a button.

Low-noise, remote-controlled motor-driven volume control (VSX-9300S/7300/5300/3300/3300S)

You can adjust the level of sound from across the room using the handy remote. Moreover, since the level is adjusted by a motor driven control, it will not add noise and distortion to the signal as electronic controls often do.

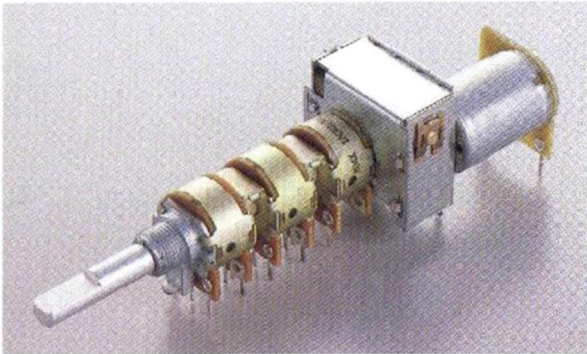

Non-Switching Amp Type II eliminates switching distortion**

The VSX-9300S, VSX-7300 and VSX-5300 are equipped with Pioneer's revolutionary Non-Switching power amplifier (Type II), contained in an IC. It uses a high-speed servo called "Vari-Bias"*** that automatically adjusts the bias current to power transistors in accordance with input level. During operation, the power transistors are never switched off; therefore, switching distortion is totally avoided, overall distortion is dramatically reduced, and music is reproduced faithfully with a new sense of clarity.

Moreover, our Non-Switching Amp Type II reduces the type of intermodulation distortion caused by changes in temperature and improves linearity in output thirtyfold. These improvements have resulted in better reproduction and more stable electrical performance. Our Non-Switching Amps also have the ability to drive low-impedance loads, making them ideal for the reproduction of highly transient digital sound.

Station ID display (VSX-9300S/7300/5300)

As you preset a station, you can also assign it a four-character ID (alphabets, numbers and some punctuation marks) and commit it to the memory. Use this convenience to give stations names like "JAZZ" and "NEWS," or identify stations with their call letters. To recall any of the stations you've given IDs, just punch in the preset number of a desired station.



HITS (Hyper Intelligent Tuning System) (VSX-9300S/7300)

HITS lets you scan all the named stations beginning with characters you specify (e.g. type in "J" to scan stations with names "JAZZ," "JAZ2," "JAZ3," etc.); automatically scan up and down the band in 1MHz steps (FM), 200kHz steps (AM) for the next station; or automatically tune a station in the vicinity of a frequency you input.

* "Dolby," "Dolby Surround" and "Pro-Logic" are trademarks of Dolby Laboratories Licensing Corporation.

**Non-Switching and Vari-Bias are trademarks of Pioneer Electronics.

Pioneer SR

Remote control units provided with Pioneer audio/video receivers are designed to control other products carrying the Pioneer "SR" (System Remote) logo in addition to the components they come with originally. For example, the remote for the VSX-9300S receiver controls the components shown below. With an SR system, you can conveniently control a number of Pioneer products from a single remote unit. Please note, however, that some remote functions may not work for certain components.

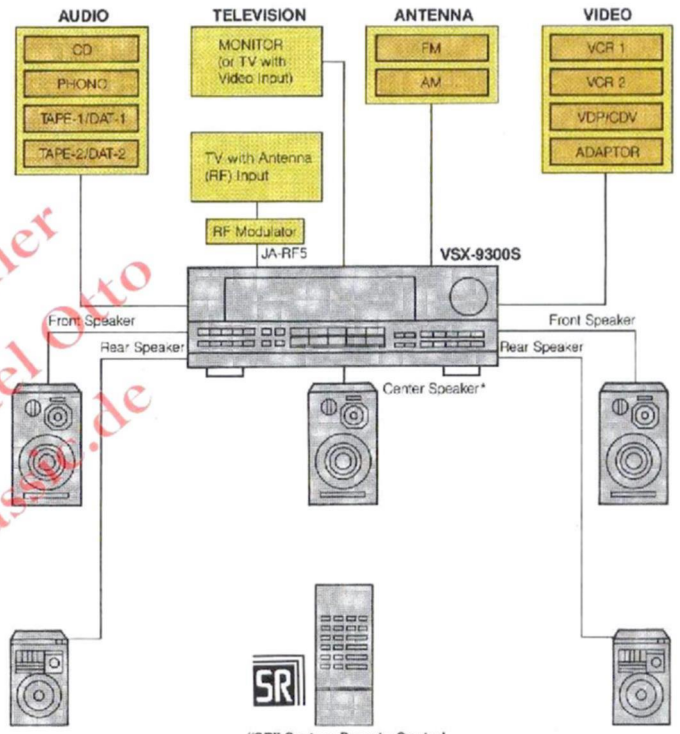

*Note: An additional monaural amplifier is required to drive the center speaker.

1MHz Station Sweep

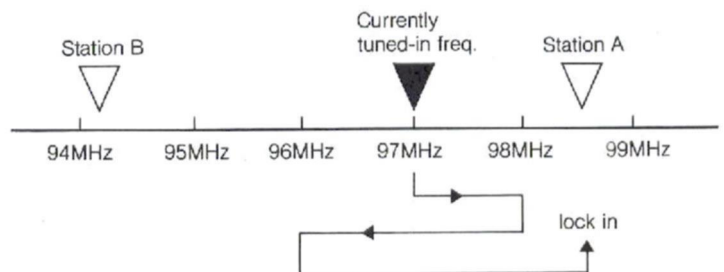



VSX-9300S

SR NON SWITCHING AMP™ DD DOLBY SURROUND PRO LOGIC

Audio/Video Quartz-Synthesizer Receiver with Non-Switching Amp and Smart Remote™

- **Stereo mode:** Continuous average power output of 125 watts* per channel, min., at 8 ohms, from 20Hz to 20,000Hz with no more than 0.005% total harmonic distortion.
- **Surround mode:** Continuous average power output of 125 watts* per channel, min., at 8 ohms, from 20Hz to 20,000Hz with no more than 0.005% total harmonic distortion (front); 30 watts per channel, min., at 8 ohms, at 1kHz with 0.7% THD (surround).
- **Dolby Pro-Logic Surround with adjustable digital delay:** For amazing wrap-around video sound. Test-tone generator permits precise channel balance.
- **Stadium and Simulated Surround:** For live musical performance and outdoor events.
- **Anti-resonance design:** Honeycomb chassis and large insulators.
- **Programmable Smart Remote™:** One remote handles the functions of most others.
- **5 video inputs (VCR-1, VCR-2, VDP/CDV, TV, VIDEO ADAPTOR):** Two monitor TVs can also be connected. Two-way dubbing is possible.
- **4 audio inputs:** TAPE-1/DAT-1, TAPE-2/DAT-2, CD, PHONO.
- **VCR-1 record selector:** Dub while you watch a different video.
- **Video signal selector:** For independent audio and video switching.
- **Simulated Stereo:** Makes mono sound fuller and more enjoyable.
- **Split-screen video enhancer.**

- **Video recording enhancer:** It's even possible to enhance a record signal without processing the picture being viewed.
- **VCR noise filter:** For hiss-free video sound.
- **Acoustic memory:** Offers five customized responses.
- **Exclusive Non-Switching Circuit Type II**
- **Random preset of 30 FM/AM stations.**
- **HITS with IDs for 30 stations.**
- **Direct-access tuning, memory scan and auto tuning.**
- **5-ganged low-noise, remote-controlled motor-driven volume control.**
- **Speaker A/B/Rear selector.**
- **Oversized fluorescent display.**
- **60/30-minute sleep timer.**

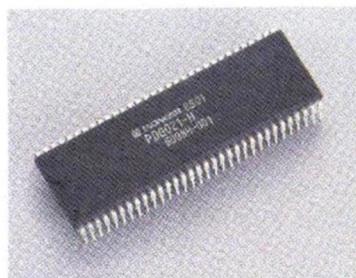

High-integration Microprocessor

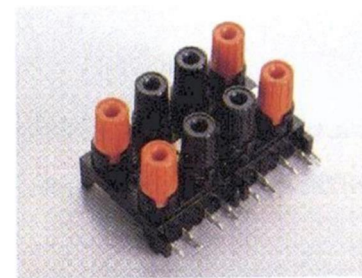

Large, Heavy-duty Speaker Terminals

*Measured pursuant to the Federal Trade Commission's Trade Regulation Rule on Power Output Claims for Amplifiers.



PIONEER SMART REMOTE™

Our Smart Remote™ is what its name implies — smart. There are two reasons why. One, it controls not only the VSX-9300S, but it also comes preprogrammed to control Pioneer SR (System Remote) audio and video components (CD player, cassette deck, LD player, TV, VCR, etc.). And two, you can program its functions as you like: it has the capacity to learn functions from other remote controls for most audio or video components so long as they are of infrared type. So with our Smart Remote in hand, you can handle just about every audio and video operation from the comfort of your chair. It has 68 keys offering 225 functions (max.), of which 154 are programmable.

Programming the remote is just as simple: put ours head-to-head with other remotes, slide the switch to LEARN, and press corresponding buttons.

**With infrared remote control units of other makes that use special signal types, programming functions may not be possible.*

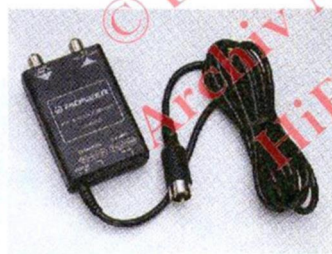

JA-RF5

RF Modulator

Even if yours is a conventional TV with no video inputs, you can connect it to our A/V receivers with the JA-RF5 RF modulator. It converts baseband video signals into RF signals for the antenna input of a regular TV.



S-X7



Surround Speaker System

- Compact and lightweight (3 lbs. 5 oz./1.5kg)
- Wide installation versatility: Can be hung on the wall or from the ceiling for stereo or surround sound
- 3-1/2-inch (8.7cm) full-range speaker.
- 30 watts (max music power).

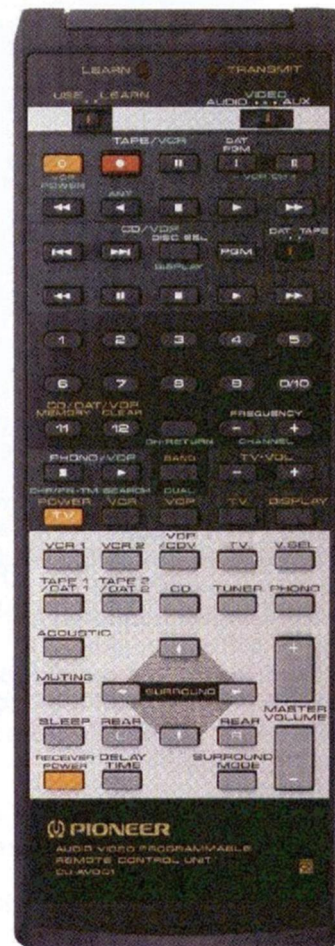



VSX-7300 NON SWITCHING AMP*

Audio/Video Quartz-Synthesizer Receiver with Non-Switching Amp

- **Stereo mode:** Continuous average power output of 125 watts* per channel, min., at 8 ohms, from 20Hz to 20,000Hz with no more than 0.005% total harmonic distortion.
- **Surround mode:** Continuous average power output of 125 watts* per channel, min., at 8 ohms, from 20Hz to 20,000Hz with no more than 0.005% total harmonic distortion (front); 30 watts per channel, min., at 8 ohms, at 1kHz with 0.7% THD (surround).
- **Dolby Surround with adjustable digital delay:** For amazing wrap-around video sound.
- **Stadium and Simulated Surround:** For live musical performance and outdoor events.
- **Full-function A/V remote control.**
- **5 video inputs (VCR-1, VCR-2, VDP/CDV, TV, VIDEO ADAPTOR):** Two monitor TVs can also be connected. Two-way dubbing is possible.
- **4 audio inputs:** TAPE-1/DAT-1, TAPE-2/DAT-2, CD, PHONO.
- **VCR-1 record selector:** Dub while you watch a different video.
- **Video signal selector:** For independent audio and video switching.
- **Simulated Stereo:** Makes mono sound fuller and more enjoyable.
- **Split-screen video enhancer.**
- **Video recording enhancer:** It's even possible to enhance a record signal without processing the picture being viewed.
- **VCR noise filter:** For hiss-free video sound.
- **Acoustic memory:** Offers five customized responses.
- **Exclusive Non-Switching Circuit Type II.**
- **Random preset of 30 FM/AM stations.**
- **HITS with IDs for 30 stations.**
- **Direct-access tuning, memory scan and auto tuning.**
- **Low-noise, remote-controlled motor-driven volume control.**
- **Speaker A/B/Rear selector.**
- **Oversized fluorescent display.**
- **60/30-minute sleep timer.**





VSX-5300



Smart Remote for VSX-3300S



VSX-3300

VSX-5300 NON SWITCHING AMP*

Audio/Video Quartz-Synthesizer Receiver with Non-Switching Amp

- **Stereo mode:** Continuous average power output of 100 watts* per channel, min., at 8 ohms, from 20Hz to 20,000Hz with no more than 0.005% total harmonic distortion.
- **Surround mode:** Continuous average power output of 100 watts* per channel, min., at 8 ohms, from 20Hz to 20,000Hz with no more than 0.005% total harmonic distortion (front); 15 watts per channel, min., at 8 ohms, at 1kHz with 0.7% THD (surround).
- **Dolby Surround with adjustable digital delay.**
- **Stadium and Simulated Surround.**
- **Full-function A/V remote control.**
- **3 video inputs (VCR-1, VCR-2, VDP/CDV):** Two monitor TVs can also be connected. Two-way dubbing is possible.
- **4 audio inputs:** TAPE-1/DAT-1, TAPE-2/DAT-2, CD, PHONO.
- **Video signal selector.**
- **Simulated Stereo.**
- **Split-screen video enhancer.**
- **VCR noise filter:** For hiss-free video sound.
- **Acoustic memory:** Offers five customized responses.
- **Exclusive Non-Switching Circuit Type II**
- **Random preset of 30 FM/AM stations without IDs.**
- **Customized IDs for 10 preset stations.**
- **Direct-access tuning, memory scan, auto tuning.**
- **Low-noise, remote-controlled motor-driven volume control.**
- **Speaker A/B/Rear selector.**
- **Oversized fluorescent display.**
- **60/30-minute sleep timer.**

VSX-3300/3300S

Audio/Video Quartz-Synthesizer Receiver

- **Continuous average power output of 80 watts* per channel, min., at 8 ohms, from 20Hz to 20,000Hz with no more than 0.05% total harmonic distortion**
- **2 video inputs (VCR/TAPE-1 and VDP/CDV):** A monitor TV can also be connected. Dubbing is possible.
- **3 audio inputs:** TAPE-2/DAT, CD, PHONO.
- **Speaker matrix surround:** Simplified video surround.
- **Programmable Smart Remote™ (VSX-3300S):** One remote for all. It has 65 keys for 170 functions (max.), of which 40 are programmable.
- **Full-function A/V remote control (VSX-3300).**
- **Video signal selector:** For independent audio and video switching.
- **Simulated Stereo:** Makes mono sound fuller and more enjoyable.
- **Random preset of 24 FM/AM stations.**
- **Memory scan and auto tuning.**
- **Low-noise, remote-controlled motor-driven volume control.**
- **5-band graphic equalizer:** 100Hz, 330Hz, 1kHz, 3.3kHz, 10kHz.
- **Speaker A/B selector.**
- **Large fluorescent display.**

*Measured pursuant to the Federal Trade Commission's Trade Regulation Rule on Power Output Claims for Amplifiers.



SX-2300



SX-1300

SX-2300



Quartz-Synthesizer Receiver

- Continuous average power output of 60 watts* per channel, min., at 8 ohms, from 20Hz to 20,000Hz with no more than 0.07% total harmonic distortion.
- **Speaker matrix surround:** Just add two more speaker systems to your present hi-fi system to enter the exciting world of surround sound. Video sound especially benefits from this circuit.
- **Simulated Stereo:** Makes mono sound fuller and more enjoyable.
- **Random preset for 24 FM/AM stations:** Up to 24 FM and AM stations can be tuned and memorized as presets.
- **Auto tuning:** Lets you tune in the next station up or down the tuning band.
- **Memory scan:** Lets you automatically sample each and every preset station.
- **5-band graphic equalizer:** To shape the music to your taste and to overcome aberrations in system response.
- **Speaker A/B selector.**
- **Large fluorescent display.**
- **Microcomputer control:** For precise control of amp, tuner and fluorescent display circuits.
- **5 audio inputs:** TAPE-2, TAPE-1/DAT, VCR/LINE, CD, PHONO.

SX-1300

Quartz-Synthesizer Receiver

- Continuous average power output of 40 watts* per channel, min., at 8 ohms, from 20Hz to 20,000Hz with no more than 0.07% total harmonic distortion.
- **Random preset for 24 FM/AM stations:** Up to 24 FM and AM stations can be tuned and memorized as presets.
- **Auto tuning:** Lets you tune in the next station up or down the tuning band.
- **Memory scan:** Lets you automatically sample each and every preset station.
- **5-band graphic equalizer:** To shape the music to your taste and to overcome aberrations in system response.
- **Speaker A/B selector.**
- **Large fluorescent display.**
- **Microcomputer control:** For precise control of amp, tuner and fluorescent display circuits.
- **5 audio inputs:** TAPE-2, TAPE-1/DAT, VCR/LINE, CD, PHONO.

*Measured pursuant to the Federal Trade Commission's Trade Regulation Rule on Power Output Claims for Amplifiers.

INTEGRATED AMPLIFIERS & FM/AM TUNERS

Digital criteria in amplifier design

Our experience in digital audio has shown us that the wide dynamic range of digital programs can only be fully enjoyed when an amplifier meets three performance criteria. One, it should be capable of driving low impedances of 4 ohms or less, overcoming variations in speaker impedance. Two, it should reproduce bass frequencies as capably as high and mid frequencies. Three, it should have the ability to reproduce music at low levels with the richness of higher levels. That's in addition to basic specification requirements like low noise and distortion.

The A-717 integrated amplifier is designed to meet these criteria. Using the shortest possible signal paths, an elaborate power supply, non-resonating mechanical construction, and state-of-the-art electronic designs, we have created an amplifier specifically made for the superb reproduction of digital music.

Direct connection

With our A-717, a program signal goes through the most direct path on its way to the power output stage, keeping the chance of noise contamination to a minimum and maintaining musical integrity and purity. We've made this possible by arranging the chassis layout so that the selection of inputs and record sources, and volume adjustment occur deep inside the cabinet; switching is performed by a long shaft or wire cable running to and from the front panel.

Moreover, to ensure the most direct connection possible between input and output, we have provided a direct-connect switch called "LINE DIRECT." When it is turned on the signal is routed from the input selector directly to the power amp, bypassing all intervening circuits except for volume control. Use of a minimum number of contacts has resulted in the purest possible signal transmission, bringing you unusually clear and clean reproduction from any program source.

Another way we've improved purity is by separating the phono circuit, power amp circuit, power supply and power output stage into individual compartments. This prevents circuits that handle high current from affecting inputs that amplify low-level signals.

Anti-vibration concept

In order to shut out sound degradation due to subtle vibration, we've used parts and construction that are highly resistant to vibration and resonance. The insulators, bottom plate and shields separating the circuit blocks have honeycomb-like rib patterns. And the heatsink chimney also has a honeycomb cross-section. Honeycomb construction ensures not only high resistance to vibration, it also increases the mechanical rigidity of the entire enclosure.

Low-impedance driving capability

The A-717 is designed to capably drive low impedances, a feature especially important when used with a quality speaker for playback of digital programs. What makes it all possible is the combination of direct circuit connection, a large-capacity power supply and the Type III Non-Switching Circuit.

The power supply circuit of the A-717 is elaborate. Two power transformers are employed in parallel connection. They feature a high total capacity, generating high currents to supply energizing power to the internal amplifiers at very low impedance. They are contained in finned die-cast cases which dissipate heat efficiently, preventing an increase in resistance due to high temperature. Thanks to the heavy die-cast casing, the transformers are strongly resistant to resonance. Moreover, the magnetic flux is fully contained within, so that magnetic radiation will not affect delicate signals, causing muddy sound. Our new transformer design combines the advantages of the popular EI-core transformer and a quality toroidal.

New Non-Switching Circuit Type III

Another major design feature is our Non-Switching Circuit which has put an end to switching distortion, adding clarity to the sound you hear. Now, this unique circuit has been upgraded for even better performance. Named Type III, the newest version combines a number of benefits to make our amplifiers ready to take on the digital challenge. One, distortion is reduced to 1/50th the original value when high currents are drawn. Two, lower distortion is achieved at lower impedances. Three, thermal distortion is reduced to zero, with quiescent currents stabilized at power-on and during operation. All this adds up to an improved signal-to-noise ratio and better sonic transparency.

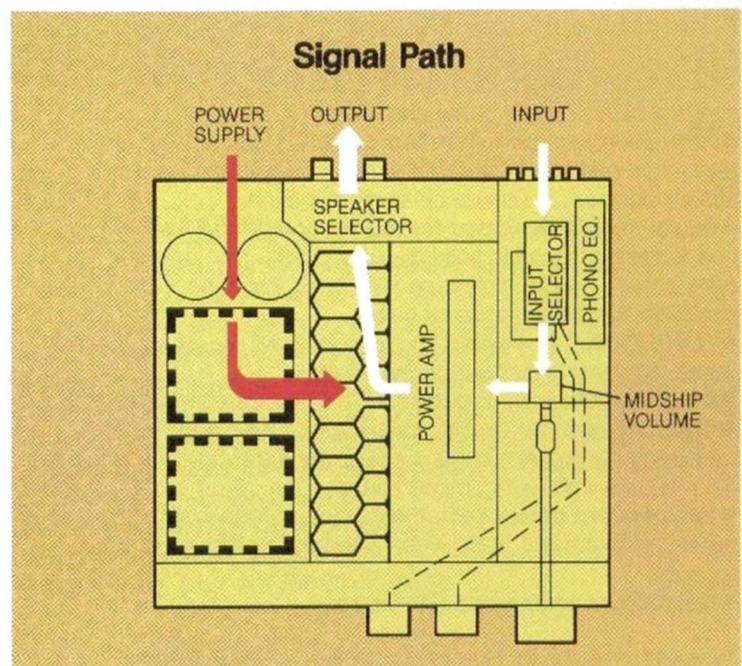



A-717

NON SWITCHING AMP™

Non-Switching Integrated Amplifier

- **Continuous average power output of 100 watts* per channel, min., at 8 ohms, from 20Hz to 20,000Hz with no more than 0.003% total harmonic distortion (135 watts* at 4 ohms with 0.005% THD).**
- **Exclusive Non-Switching Circuit Type III:** Ends switching distortion, improves linearity and thermal stability, and better drives low impedance (4 ohms or lower).
- **Separate voltage- and output-amplifying stages:** Steady performance is guaranteed, uninfluenced by load variations.
- **Separate circuit blocks:** For minimum interference between circuits.
- **Direct connection:** Input signal goes through the technically shortest path to retain purity and integrity.
- **Anti-resonance and vibration designs:** Honeycomb chassis separators and heat sink resist vibration, and large insulators absorb vibration, to ensure clear reproduction.
- **Power supply designed for higher power and low impedance:** Housed in solid die-cast cases, twin power transformers feature high capacity, damp resonance, and contain magnetic flux, for exceptional clarity.
- **"LINE DIRECT" switch:** For bypassing all secondary circuits except for volume; highest purity results.
- **8 inputs:** Included are three for TAPE and one for ADAPTOR.
- **"Hybrid" booster for MC cartridges:** Combined use of transformer and optimum-gain phono equalizer ensures extended, flat response and well-damped sound.
- **Independent power switch for phono:** Phono circuit may be turned off to prevent noise when listening to other program sources.
- **Gold-plated phono and CD inputs.**

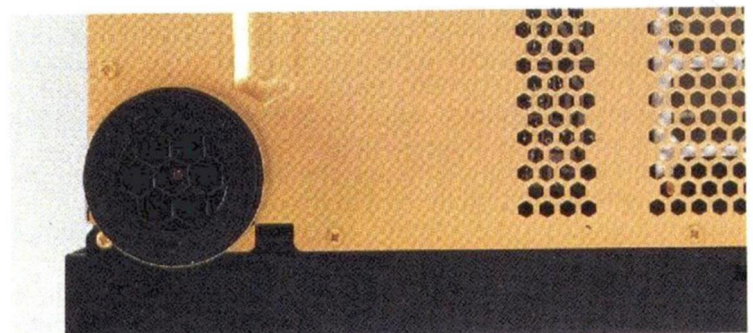

*Measured pursuant to the Federal Trade Commission's Trade Regulation Rule on Power Output Claims for Amplifiers.



VSA-910

SR NON SWITCHING AMP*

DD DOLBY SURROUND™

VSA-910

A/V Surround Amplifier with Digital Delay

- **Stereo mode:** Continuous average power output of 100 watts* per channel, min., at 8 ohms, from 20Hz to 20,000Hz with no more than 0.005% total harmonic distortion.
- **Surround mode:** Continuous average power output of 70 watts* per channel, min., at 8 ohms, from 20Hz to 20,000Hz with no more than 0.005% total harmonic distortion (front); 30 watts* per channel, min., at 8 ohms, from 20Hz to 20,000Hz with no more than 0.08% total harmonic distortion (surround).
- **Exclusive Non-Switching Circuit Type II.**
- **Dolby, Stadium and Simulated Surround, with digital delay.**
- **4 video inputs:** Dubbing is possible.
- **Split-screen video enhancer.**
- **Programmable Smart Remote™.**
- **Acoustic memory for three bass/treble tone settings.**
- **Super bass.**
- **On-screen display.**
- **Large multi-function fluorescent display.**



F-717

Digital Direct Decoder FM/AM Tuner

- **Pioneer's Digital Direct Decoder:** Digital processing is combined with direct conversion from FM to left/right audio outputs to improve every major tuner specification.
- **Linear front end:** Features electronic twin-varicaps to reduce RF intermodulation distortion and expand dynamic range.
- **"Pulse swallow" frequency synthesis:** Using an ultrasonic reference frequency, it provides stable reception and a high signal-to-noise ratio.
- **Random presets for 16 FM/AM stations:** Favorite stations may be preset and recalled at a touch.
- **Improved AM sound:** A large loop antenna and an FET buffer for the tuning coil assure clean AM sound.
- **3-point signal indicator.**
- **AM stereo adapter terminal:** Allows you to upgrade to AM stereo any time.

F-551

Quartz-PLL FM/AM Tuner

- **Pioneer CCTS (Computer-Controlled Tuning System):** Tracking error is automatically minimized to provide low noise and distortion. Also, the hi-blend circuit is automatically turned on to reduce stereo noise when the signal is weak.
- **Three-speed search:** One touch tunes each and every station; a sustained push causes the tuner to search for only powerful stations; and a more sustained touch quickens the search speed.
- **Random presets for 24 FM/AM stations:** Favorite stations may be preset and recalled at a touch.
- **Digital readout of signal strength.**
- **Digital frequency display.**
- **Pioneer SR (System Remote) ready.**

F-717

F-551

SR

8-times oversampling digital filter (PD-M700/7100)

The Compact Disc format uses a sampling frequency of 44.1kHz, to provide a frequency bandwidth of from about 0Hz to 20kHz. This frequency can result in the generation of "sampling" noise because its "foldover" frequencies are spectrally close to the audible frequency range. These spurious frequencies — known as sampling noise — are normally eliminated by a higher-order analog filter with steep attenuation response. Such filters, though, tend to cause a phase lag in frequencies of 10kHz and higher, making accurate signal reproduction impossible.

Our 8-times oversampling digital filter offers the solution. It samples the input signal at 8 times the normal frequency (that's 352.8kHz), shifting the spurious frequencies far out of the audio range. This makes it possible for us to use a low-order analog filter, made from high-quality discrete parts, with mild attenuation response to remove the spurious frequencies. So our 8-times oversampling digital filter ends noise due to foldover frequencies, while maintaining accurate phase linearity up to 20kHz and enabling low-distortion output.

We also use 4-times and 2-times oversampling digital filters in other models to bring you similar benefits.

Quantization noise generation (conceptual)

16-bit Sampling

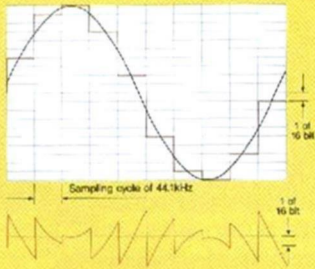

16-bit 8-times Oversampling

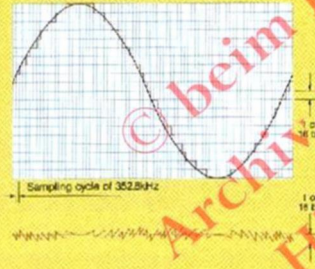

Spectra of sampling noise

No oversampling

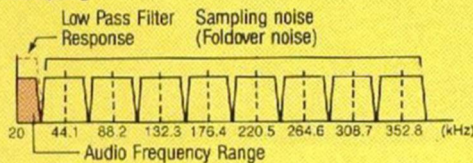

8-times oversampling

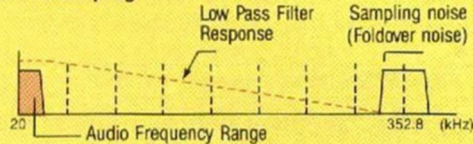

The linear-envelope twin D/A converter system (PD-M700/M600/7100)

Our linear-envelope D/A converter system is one of the most advanced designs. Conventional converters use 16 current sources to convert 16-bit data into analog output; with them even the slightest error in the current source can lead to conversion distortion. With our new linear-envelope converter, however, we've virtually eliminated the current-source error, thus ending conversion distortion. Moreover, there are two converters, one for each channel, to end inter-channel phase difference and to provide better sound imaging. And each is a glitch-free type for lower noise.

Pioneer Accu-Focus System (PD-M700/M600/M500/7100)

The laser beam that reflects off pits on the surface of the Compact Disc holds billions of bits of digital musical information. The beam is detected by a pickup and the signals are passed on to a photo-detector where they are converted into electric RF signals. The photodetector is divided into four components to control the focus servo, inevitably causing phase difference between the four signals the detector has received. The Accu-Focus System, however, solves this phase-related problem by adding a delay circuit for the first-arriving signals, thus dramatically reducing distortion and improving frequency response in the RF output, especially at high frequencies. As a result, both noise and distortion are reduced in the audible frequency range.

Pioneer-exclusive ACCU-FOCUS system with laser pickup

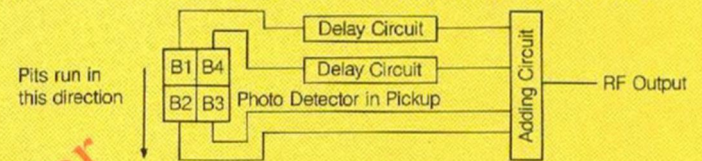

B1 and B4 receive signals before B2 and B3 do. B1 and B4 signals are sent to their own delay circuits, and then applied to the adding circuit. There all four signals are synchronized and then output as RF signals, resulting in a high signal-to-noise ratio and low distortion.

Comparison of error rate

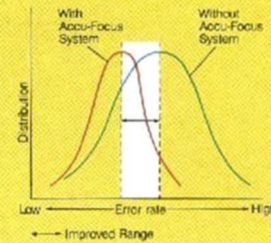

Anti-resonance concept

To ensure superb disc tracking and great sound, we've come up with the "anti-resonance concept." This concept is expressed in our CD players in the following ways.

- **Honeycomb chassis (all models):** The chassis of all our CD players have a ribbed honeycomb construction. This design not only increases rigidity but also protects the pickup and disc drive system inside from vibration generated by speakers and other external influences.

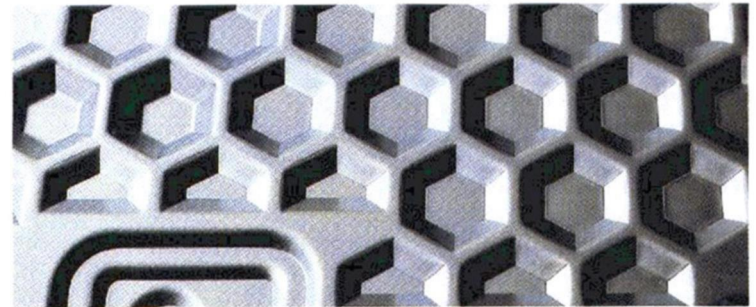

- **Magnetic-clamp disc stabilizer (PD-7100/5100/4100):** With conventional players, the rotating disc is clamped just at the center, leaving the middle section and outer rim subject to external vibration and acoustic pressure. But our magnetic-clamp disc stabilizer secures the disc both at its center and middle section. Moreover, a magnetic clamping is used in combination so that the clamped disc is completely detached from the player during playback. This prevents spurious vibration from the disc from being transmitted to the electronic circuits.

- **Large insulators (PD-M700/M600/M500/7100/5100):** Highly rigid vibration-damping insulators protect the player from shocks and vibration.

- **New linear-motor pickup drive with low-center-of-gravity FRP (Fiber Reinforced Plastics) base (PD-7100):** This new drive ensures accurate and stable disc tracking and comfortably quick access to individual tracks.

- **Ballast base with ceramic supports (PD-5100/4100):** The base of the pickup mechanism has a lower center of gravity to improve stability. And the suspension system uses ceramic supports in combination that are highly rigid and feature optimized internal loss. As a result, rolling of the pickup mechanism base is drastically reduced, allowing the pickup to read the disc with exceptional precision.

Optical and coaxial digital outputs (PD-M700/7100)

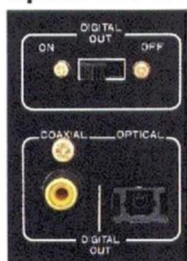

There are two digital outputs on the PD-7100 and PD-M700 that permit direct connection with other digital equipment (such as an amplifier with a built-in D/A converter). Of the two outputs, one is for optical connection to completely shut out digital noise.

Optical Connection Cable

Here's a high-performance optical cable for transmission of digital output from our CD players with optical digital output to other digital equipment with matching input — equipment like our D/A converter-equipped amp. The cable uses a bundled quartz glass-fiber core featuring low loss, wide band transmission, high insulation and light weight. The connector uses a precision metal ferrule. The cable has the three-layer construction to withstand twisting, shock, humidity and extreme temperatures.

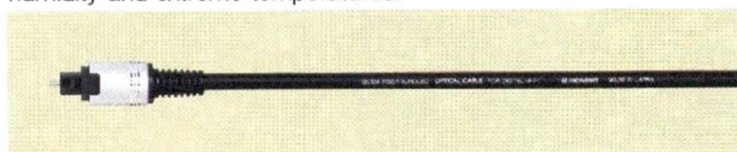

JLL-AP115T (optional) Length 4' 11" (1.5m)

Convenient 6-disc multi-play magazine format (PD-M700/M600/M500/M400)

Our multi-play Compact Disc players let you enjoy digital sound for hours and hours, uninterrupted. They each accept up to six CDs mounted inside a special magazine, and play the discs the way you want them played: sequential play, programmed play, repeat, random play, etc. — features designed to welcome you to Pioneer's versatile world of digital sound.

"SR" Remote control (PD-M700/M600/M500/7100/5100)

All our CD players except for the PD-4100 and PD-M400 come equipped with a full-function remote control that includes a numeric keypad. So you can operate your CD player from the comfort of your easy chair.

What's more, the remotes for the PD-M700 and PD-M600 feature an LCD (Liquid Crystal Display) and our Magazine Program Selection System that permits you to store up to 256 "steps" (songs and pauses) from up to 10 magazines, each with 6 discs. Using the MPSS*, you are saved from programming tracks each time you mount a magazine: all you have to do is press the

memory button for that magazine and the "transfer" button. The programmed songs are then automatically "loaded" from the remote into the player. And the PD-M700's remote even lets you give each magazine an 8-letter (max.) title.

Auto program editing (PD-7100/5100)

This is a handy feature when dubbing from disc to tape. When you specify the length of a tape you're going to record on, the player automatically counts the number of tracks that can be recorded within the specified time. Conveniently, it lets you know how many tracks can be recorded on both Side A and B of a tape before dubbing actually begins.

Time fade editing (PD-M700/M600/M500/7100)

Time fade editing works somewhat like the auto program editing described above, but when you specify a time, play automatically fades smoothly out at that specified time. With our multi-play CD players (PD-M700 and PD-M600), you can even program tracks from six discs and let music fade out when the specified time is up.

"Music Window" — a totally new convenience (PD-7100)

The Music Window feature lets you fade music in and out at any point smoothly. Up to eight fades (fade-ins and fade-outs) are possible per disc. Use this feature to edit tracks to your liking — ideal for background music.

One-touch digital fade (PD-M700/M600/7100)

You can manually fade music in and out at any time. And because the fade circuit is made of a digital attenuator IC, there's no sonic degradation.

3-inch (8cm) CD playback

All our CD players let you enjoy new 3-inch (8cm) CDs. For our multi-play CD players, we make the JD-M108 multi-play magazine available for playback of six 3-inch (8cm) discs. Using optional 3-inch (8cm) disc adaptors for the JD-M100, you can play 3-inch (8cm) discs.



*MPSS is a trademark of Pioneer Electronic Corporation.

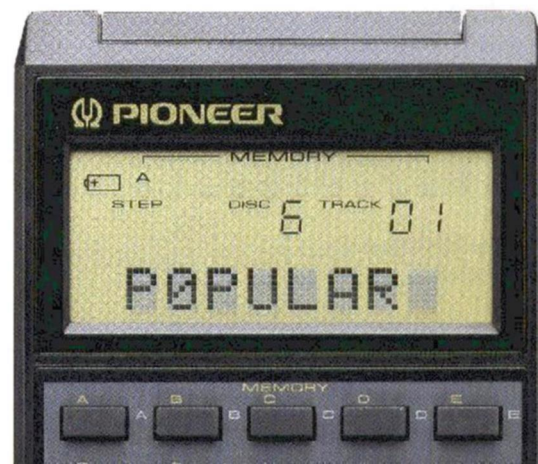



PD-M700



Multi-Play Compact Disc Player

- **8-times oversampling digital filter:** Higher resolution and lower noise.
- **Linear-envelope D/A converter system using twin glitch-free converters.**
- **Accu-Focus System:** For better frequency response in RF output.
- **Class-A FET buffer amp:** For reduced distortion and improved sound quality.
- **Four separate power supplies:** Clean sound with analog circuits insulated from digital circuits.
- **Anti-resonance concept:** Honeycomb chassis and large insulators and ribbed bonnet.
- **Optical and coaxial digital outputs.**
- **Time fade editing.**
- **Digital level control, with memory:** For low-noise precise level adjustment.
- **One-touch digital fade.**
- **Full-function SR remote control with LCD, MPSS and magazine-title indication.**
- **6-disc magazine and single-disc loader:** To allow you to enjoy both multi-disc and single-disc play.
- **3-mode random play (Normal/Program/Delete):** To add fun and variety to digital listening — random play of tracks on discs, random play of programmed tracks, and random play of tracks except for tracks you don't want to hear.
- **Random programmed play of 32 tracks for 6 discs.**
- **Programmable pause.**
- **Repeat:** All discs, programmed discs and tracks.
- **Index search.**
- **9-digit fluorescent display with disc indication:** Shown are disc number, track number, index number, elapsed time, remaining play time in a track, remaining play time in a disc, etc.
- **Headphone output with volume control.**
- **Timer play for programmed tracks at preset level (timer optional).**
- **Ready to play 3-inch (8cm) CDs:** A 3-inch (8cm) CD magazine is available as an option.
- **Battery backup for status memory.**
- **Gold-plated output jacks.**
- **Subcode output.**



Conventional D/A Converter (MSB not optimized)

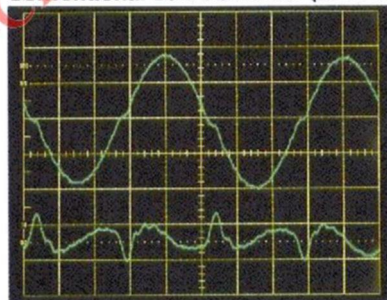

Linear-envelope D/A Converter (MSB optimized)

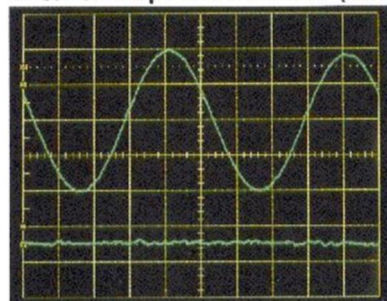

Output and Distortion Waveforms of D/A Converters

Our linear-envelope D/A Converter keeps error in weighted current source for MSB (Most Significant Bit) to a minimum. Therefore, as the input switches from negative to positive, or vice versa, there's only a small amount of error. In conventional D/A converters, however, accumulated error can result in gross error.



PD-M600

Multi-Play Compact Disc Player



- 4-times oversampling digital filter.
- Linear-envelope D/A converter system with twin glitch-free converters.
- **Accu-Focus System:** For better frequency response in RF output.
- **Anti-resonance concept:** Honeycomb chassis, large insulators and ribbed bonnet.
- **Time fade editing.**
- **Digital level control:** For low-noise, precise level adjustment.
- **One-touch digital fade.**
- **Full-function SR remote control with LCD and MPSS.**
- **6-disc magazine and single-disc loader:** To allow you to enjoy both multi-disc and single-disc play.
- **3-mode random play (Normal/Program/Delete).**
- **Random programmed play of 32 tracks for 6 discs.**
- **Programmable pause.**
- **Repeat:** All discs, programmed discs and tracks.
- **Index search.**
- **9-digit fluorescent display with disc indication.**
- **Headphone output with volume control.**
- **Timer play (timer optional).**
- **Ready to play 3-inch (8cm) CDs:** A 3-inch (8cm) CD magazine is available as an option.
- **Subcode output.**

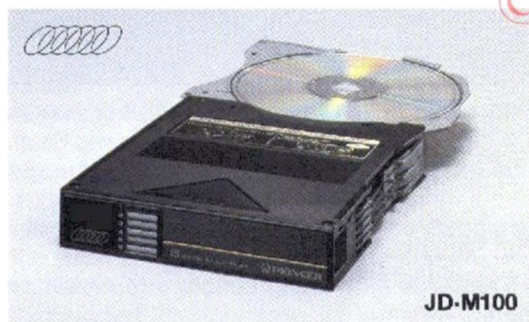

JD-M100



JD-M108

JD-M100/JD-M108

Multi-Play Magazine/3-inch (8cm) CD Multi-Play Magazine

Every Pioneer multi-play CD player comes with a magazine that holds up to six 5-inch (12cm) discs. This saves you from having to load discs each time you want to play them, and the magazine doubles as a convenient storage box. Spare magazines are available as options. The JD-M108 accepts 3-inch (8cm) CDs.

*The JD-M108 cannot be used on the following models: PD-M6, PD-M670, PD-M40, PD-M50, PD-M60, PD-M70, PD-M90X, PD-X909M, and CDX-M100.

The magazine-type Multi-Play CD players with mark and the Magazines with the same mark, are compatible for 5-inch (12cm) discs.



PD-M500



PD-M400

PD-M500



Multi-Play Compact Disc Player

- 4-times oversampling digital filter.
- Twin D/A converter system.
- **Accu-Focus System:** For better frequency response in RF output.
- **Anti-resonance concept:** Honeycomb chassis, large insulators and ribbed bonnet.
- **Time fade editing.**
- **Digital level control:** For low-noise, precise level adjustment.
- **Full-function SR remote control.**
- **6-disc magazine and single-disc loader:** To allow you to enjoy both multi-disc and single-disc play.
- **Random play:** To add fun and variety to digital listening.
- **Ready to play 3-inch (8cm) CDs:** A 3-inch (8cm) CD magazine is available as an option.
- **Random programmed play of 32 tracks for 6 discs.**
- **Programmable pause.**
- **Repeat:** All discs, programmed discs and tracks.
- **7-digit fluorescent display with disc indication.**
- **Timer play (timer optional).**



PD-M400



Multi-Play Compact Disc Player

- 2-times oversampling digital filter.
- Twin D/A converter system.
- **Anti-resonance concept:** Honeycomb chassis and ribbed bonnet.
- **6-disc magazine:** To allow you to enjoy multi-disc play.
- **Random play:** To add fun and variety to digital listening.
- **Random programmed play of 32 tracks for 6 discs.**
- **Programmable pause.**
- **Repeat:** All discs, programmed discs and tracks.
- **7-digit fluorescent display with disc indication.**
- **Timer play (timer optional).**
- **Pioneer SR (System Remote) ready.**
- **Ready to play 3-inch (8cm) CDs:** A 3-inch (8cm) CD magazine is available as an option.



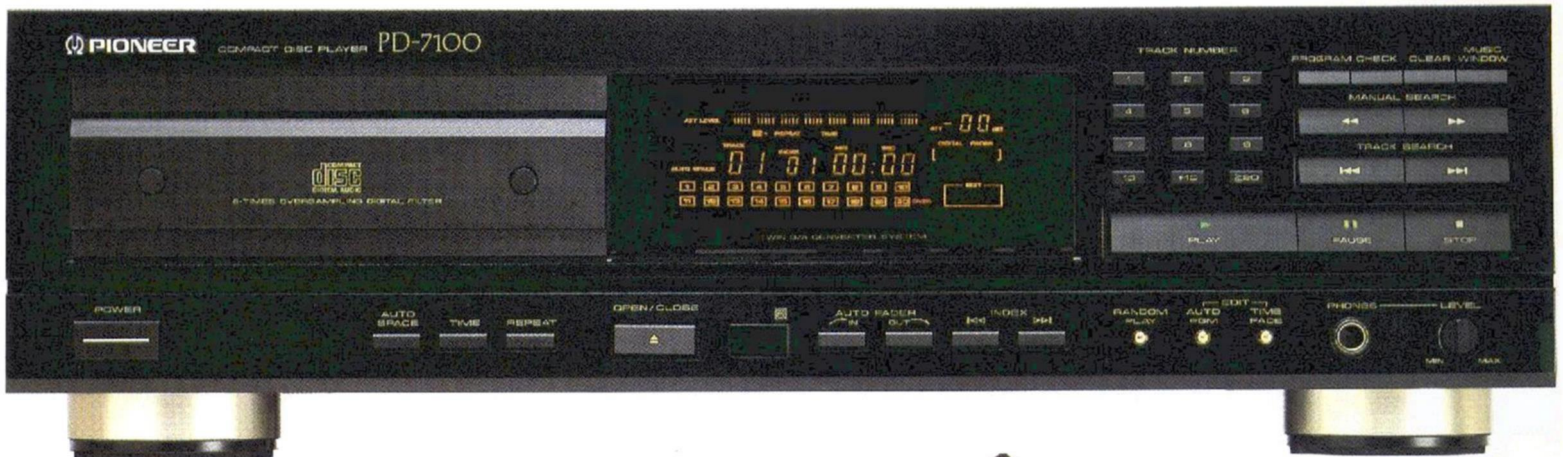

PD-7100

Compact Disc Player

- **8-times oversampling digital filter:** Higher resolution and lower noise.
- **Linear-envelope D/A converter system with twin glitch-less converters.**
- **Accu-Focus System:** For better frequency response in RF output.
- **Class-A FET buffer amp:** For reduced distortion and improved sound quality.
- **Four separate power supplies:** Clean sound because analog circuits are insulated from digital circuits.
- **Anti-resonance concept:** Honeycomb chassis, magnetic-clamp disc stabilizer, large insulators.
- **Linear-motor pickup drive:** For stable disc tracking and quick track access.
- **Optical and coaxial digital outputs.**
- **Auto program editing.**
- **Time fade editing.**
- **"Music Window."**
- **Digital level control:** For low-noise, precise level adjustment.
- **One-touch digital fade.**
- **Variable fade:** Fade time may be adjusted from 0 to 9 seconds during operation of Music Window, time fade edit or one-touch fade.
- **Full-function SR remote control.**
- **Random play:** To add fun and variety to digital listening.
- **Ready to play 3-inch (8cm) CDs.**
- **Random programmed play of 24 tracks.**
- **Programmable pause.**
- **Repeat:** 1 track, all tracks, programmed tracks.
- **Auto space.**
- **Index search.**
- **20-track music calendar.**
- **10-digit fluorescent display.**
- **Headphone output with volume control.**
- **Timer play (timer optional).**
- **Subcode output.**

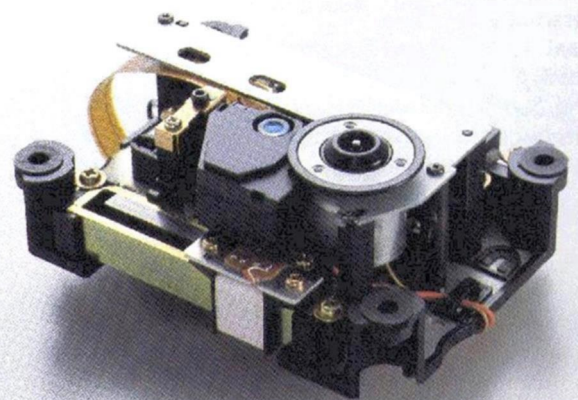

Optical Pickup Mechanism Driven by Linear Motor



PD-5100



PD-4100

PD-5100



Compact Disc Player

- 4-times oversampling digital filter.
- Twin D/A converter system.
- **Anti-resonance concept:** Honeycomb chassis, magnetic-clamp disc stabilizer, large insulators, ballast base with ceramic supports.
- Auto program editing.
- Full-function SR remote control.
- Random play: To add fun and variety to digital listening.
- Ready to play 3-inch (8cm) CDs.
- Random programmed play of 20 tracks.
- Programmable pause.
- Repeat: All tracks and programmed tracks.
- 20-track music calendar.
- 8-digit fluorescent display.
- Headphone output with volume control.
- Timer play (timer optional).

PD-4100



Compact Disc Player

- 2-times oversampling digital filter.
- Twin D/A converter system.
- **Anti-resonance concept:** Honeycomb chassis, magnetic-clamp disc stabilizer, ballast base with ceramic supports.
- Random play: To add fun and variety to digital listening.
- Ready to play 3-inch (8cm) CDs.
- Random programmed play of 20 tracks.
- Programmable pause.
- Repeat: All tracks and programmed tracks.
- 6-digit fluorescent display.
- Timer play (timer optional).
- Pioneer SR (System Remote) ready.

CASSETTE DECKS

Dolby HX Pro (CT-W900R/S800/S600)

Dolby HX Pro is just the circuit for taping digital programs: it extends the high-frequency "headroom" for a flat frequency response at higher frequencies, thus expanding the overall dynamic range. The circuit monitors the high-frequency contents in the music that appear at the record head and automatically adjusts the bias current in real-time according to the level of the high-frequency signals. Results? Improved high-frequency response.

Here's why: during recording, "bias" is applied to the record head along with musical signals to improve linearity. More bias boosts the output at low and mid frequencies, but reduces the output of high frequencies. Conversely, lower bias improves high-frequency response, but results in increased distortion. So, the bias is set at a value after balancing mid-frequency distortion, sensitivity and maximum output level.

But with digital sound, high-frequency signals, which digital programs contain in abundance, automatically increase the bias, causing a phenomenon called "self-biasing." This means that the more high-frequency information music contains, the more it suffers from poor high-frequency response. The Dolby HX Pro, however, minimizes self-biasing by automatically reducing bias when there is a lot of high-frequency information.

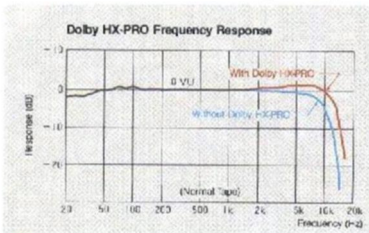

Incidentally, Dolby HX Pro works only during the recording process, so its benefits can be extended to even home decks, headphone stereos and car cassette players that do not contain the circuit.

Cassette stabilizer (CT-W900R/S800/S600)

Even barely detectable vibrations in the cassette, caused by the rotating motors and sound pressure, can muddy taped sound. So we've come up with a new, effective way to damp these vibrations — the cassette stabilizer. With it, a rubber liner and resin pressure pads firmly clamp the loaded cassette in place from front and back, never allowing it to budge. Audible results are exceptional clarity and better sound-image definition.

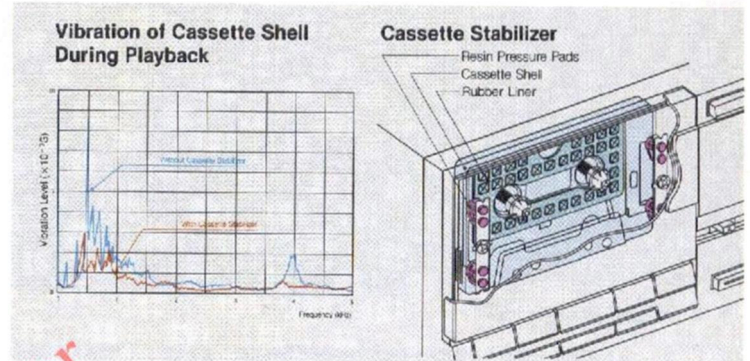

Direct connection (CT-S800)

Circuits are connected to each other as directly as possible to reduce transmission loss, avoid noise pickup and prevent other forms of signal degradation. For instance, we've positioned the input level control and balance control near the input terminals and used long shafts running from the front panel for level and balance adjustment, to trim the wiring between input and output to the shortest possible length. In this way we've ensured that the delicate nuance of music will be accurately reproduced.

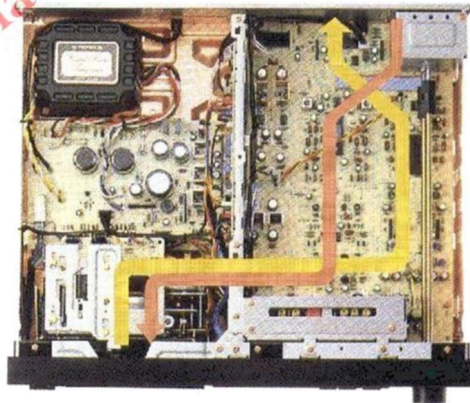

Honeycomb construction (all models except CT-W300)

Resonance and vibration are effectively damped by the use of a honeycomb chassis and (in the CT-S800) honeycomb separator. Those parts also contribute to making the entire chassis rigid and more resistant to external force. With resonance and vibration fully damped, the tape sounds clear and clean, free of any trace of muddiness and fuzziness.

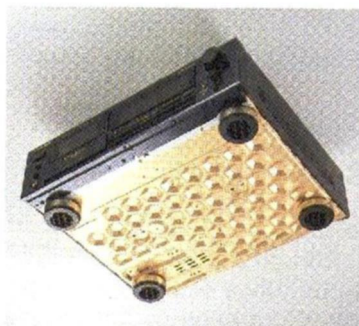

Honeycomb Chassis



Large Honeycomb Insulators (CT-W900R/CT-S800)

Pioneer "Reference Master Mechanism" (CT-S800)

Our "Reference Master Mechanism," which combines a number of precision features, ensures that digital programs are recorded with clarity and wide dynamic range totally intact. One, it uses a staggered-resonance closed-loop dual-capstan system to reduce wow & flutter and intermodulation noise. Two, the mechanical chassis is made of rigid metal sheet to firmly support the tape. Three, the capstan shafts are finished with microscopic precision, and coupled with large balanced flywheels featuring a high moment of inertia. Four, the capstan motor features smooth cog-free rotation and low generation of high-frequency vibration. Finally, the optically aligned head block is made of rigid precision die-cast zinc. It all adds up to an amazingly low wow and flutter of 0.024% (WRMS) with the CT-S800.

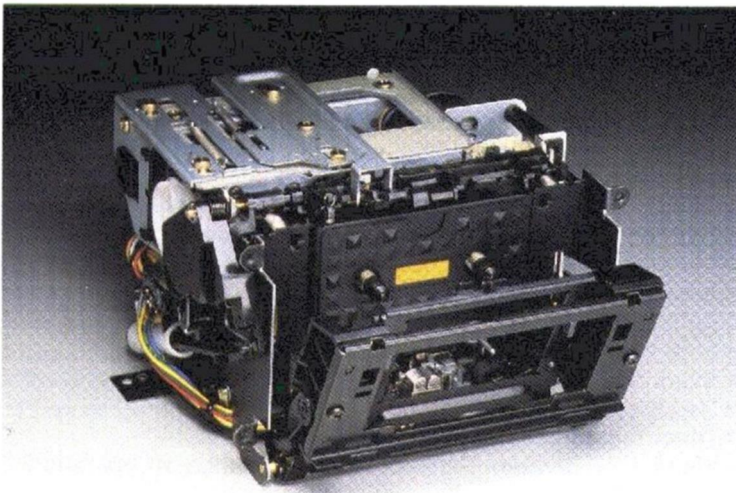

Pioneer "Reference Master Mechanism"

CT-W900R



CT-W700R

CT-W900R



Double Quick Auto-Reverse Cassette Deck

- **Two quick auto-reverse record/play full-logic cassette transports:** For the ultimate in taping ease.
- **Anti-resonance and vibration designs:** Cassette stabilizer, honeycomb chassis and large honeycomb insulators.
- **Tape dubbing:** At normal or double speed at the touch of a button thanks to the Synchro feature.
- **Relay recording/play:** For long recording and play sessions.
- **Parallel recording:** To make two tapes simultaneously.
- **Twin Dolby HX Pro:** Expands the dynamic range at high frequencies.
- **Dolby B/C noise reduction, with MPX filter:** For low-noise recording.
- **Music/Skip Search:** To zero in on a song up to 15 away, forward or back.
- **One-touch recording.**
- **Peak level meters with peak hold.**
- **Auto-switching electronic 4-digit tape counter for Deck I and II.**
- **Auto rec mute.**
- **Auto tape selector.**
- **Blank Search and Blank Skip.**
- **Headphone output with volume control.**
- **Timer record/play (timer optional).**
- **Pioneer SR (System Remote) ready for hands-off operation.**

CT-W700R



Double Auto-Reverse Cassette Deck

- **Two auto-reverse full-logic cassette transports:** One plays and the other plays and records in both directions.
- **Anti-resonance and vibration designs:** Honeycomb chassis and insulators.
- **Tape dubbing:** At normal or double speed at the touch of a button thanks to the Synchro feature.
- **Relay play:** For long, uninterrupted musical sessions.
- **Dolby B/C noise reduction, with MPX filter:** For low-noise recording.
- **Music/Skip Search:** To zero in on a song up to 15 away, forward or back.
- **One-touch recording.**
- **Fluorescent peak level meters.**
- **Auto-switching electronic 3-digit tape counter for Deck I and II.**
- **Auto rec mute.**
- **Auto tape selector.**
- **Blank Search and Blank Skip.**
- **Headphone output.**
- **Timer record/play (timer optional).**
- **Pioneer SR (System Remote) ready for hands-off operation.**



CT-W500



CT-W300

CT-W500



Double Cassette Deck

- **Two full-logic cassette transports:** One plays and the other both plays and records.
- **Honeycomb chassis fights resonance and vibration.**
- **Tape dubbing:** At normal or double speed at the touch of a button thanks to the Synchro feature.
- **Relay play with repeat:** Each tape can be repeated up to 6 times, for music without breaks.
- **Dolby B/C noise reduction:** For low-noise recording.
- **Music/Skip Search:** To zero in on a song up to 15 away, forward or back.
- **One-touch recording.**
- **6-segment LED level meters.**
- **Auto rec mute.**
- **Auto tape selector.**
- **Blank Skip.**
- **Headphone output.**
- **Timer record/play (timer optional).**
- **Pioneer SR (System Remote) ready for hands-off operation.**

CT-W300



Double Cassette Deck

- **Two cassette transports:** One plays and the other both plays and records.
- **Tape dubbing:** At normal or double speed at the touch of a button thanks to the Synchro feature.
- **Relay play:** For long, uninterrupted musical sessions.
- **Dolby B/C noise reduction:** For low-noise recording.
- **One-touch recording (Deck II).**
- **5-segment LED level meters.**
- **Auto tape selector (Deck I).**
- **Timer record/play (timer optional).**
- **Pioneer SR (System Remote) ready for hands-off operation (pause on/off).**

CT-1280WR



Double Auto-Reverse Cassette Deck

- **Two auto-reverse full-logic cassette transports.**
- **Dolby B/C noise reduction.**
- **Music/Skip Search.**



CT-S800

3-Head Cassette Deck

- **Pioneer "Reference Master Mechanism":** Precision tape drive with a closed-loop dual capstan system ensures precise sound.
- **Anti-resonance and vibration designs:** Rigid copper-plated honeycomb chassis, honeycomb separator, cassette stabilizer, large honeycomb insulators and cast-iron enclosed power transformer.
- **Direct connection:** Direct circuit connection and direct power supplies for pure and dynamic sound.
- **High-speed servo-regulated power supply system:** Stabilizes the power-supply voltage instantly. There's also separate power supplies for the audio, control and display circuits.
- **Dolby HX Pro:** Expands the dynamic range at high frequencies.
- **Dolby B/C noise reduction, with MPX filter:** For low-noise recording.
- **3-head design:** PCCOC (single-crystal oxygen-free copper of highest purity) wire and amorphous play head provide highest purity.
- **Auto monitor:** As recording starts, monitor automatically switches from source to tape.
- **Bias adjustment:** For flat, low-distortion response from individual tapes.
- **Fluorescent level meter with peak hold:** Range may be set from wide to expanded.
- **Music/Skip Search:** To zero in on a song up to 15 away, forward or back.
- **One-touch tape return & return play.**
- **One-touch recording standby.**
- **3-mode electronic tape and elapsed/remaining time counter.**
- **Auto rec mute.**
- **Auto tape selector.**
- **Powered eject.**
- **Headphone output with volume control.**
- **Timer record/play (timer optional).**
- **Pioneer SR (System Remote) ready for hands-off operation.**

2-Mode Fluorescent Level Meter

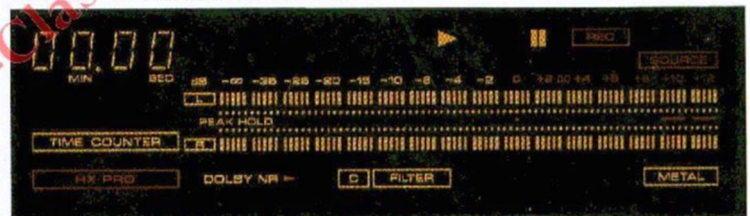

"Wide range mode"

The range covers from -35dB to $+12\text{dB}$ in 15 steps, the range suitable for music with normal dynamic range.

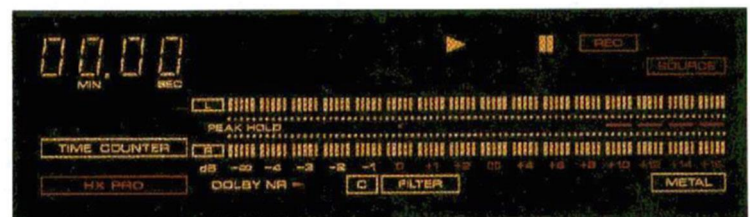

"Expanded range mode"

The range below and above 0dB is expanded, covering from -4dB to $+16\text{dB}$ in 15 steps. This is the mode for close monitoring of the recording level.

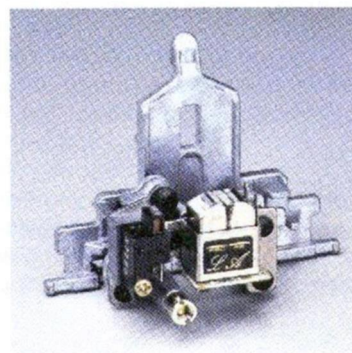

Rigid High-Precision Die-Cast Zinc Head Block

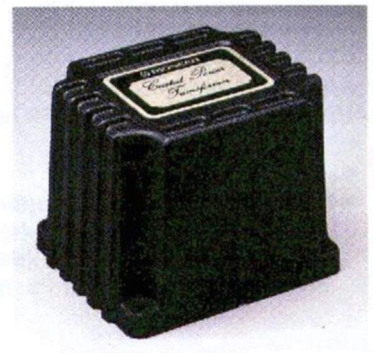

Cast-iron Enclosed Power Transformer



CT-S600

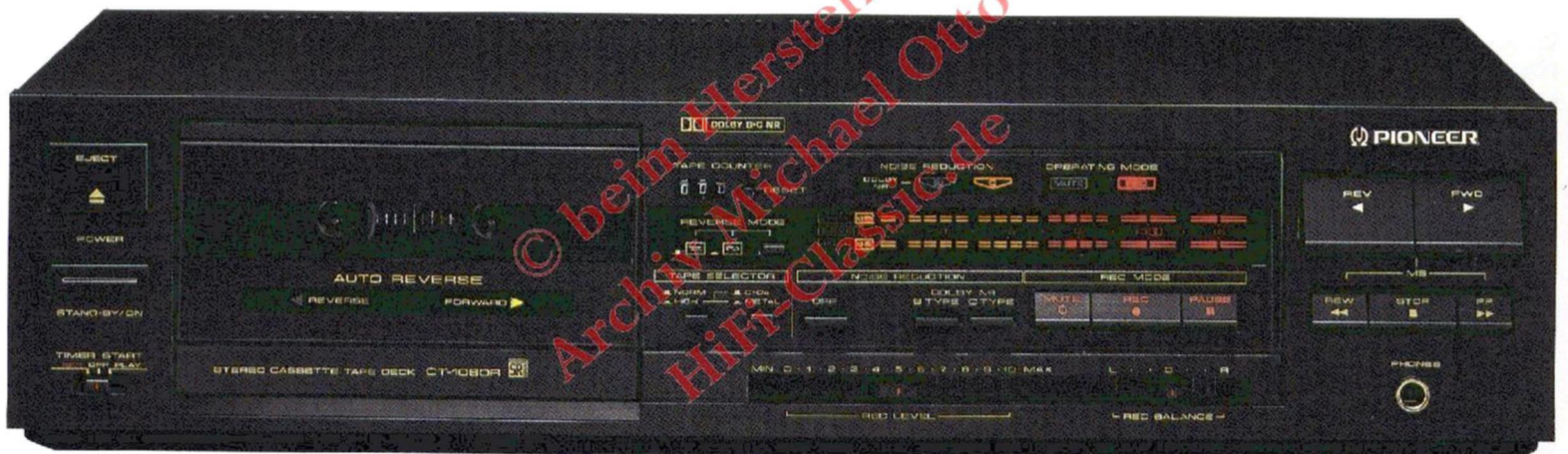

CT-1080R

CT-S600



2-Motor Cassette Deck

- **Two-motor full-logic tape control:** For precise and comfortable tape operation.
- **Anti-resonance and vibration designs:** Die-cast zinc head base, honeycomb chassis, cassette stabilizer and large insulators.
- **Dolby HX Pro:** Expands the dynamic range at high frequencies.
- **Dolby B/C noise reduction, with MPX filter:** For low-noise recording.
- **Bias adjustment:** For flat, low-distortion response from individual tapes.
- **Fluorescent level meter and 4-digit electronic tape counter.**
- **Music/Skip Search:** To zero in on a song up to 15 away, forward or back.
- **One-touch recording standby.**
- **Auto rec mute.**
- **Blank Search and Index Scan.**
- **Headphone output with volume control.**
- **Timer record/play (timer optional).**
- **Pioneer SR (System Remote) ready for hands-off operation.**

CT-1080R



Quick Auto-Reverse Cassette Deck

- **Quick auto-reverse cassette transport:** For automatic recording and playback of both sides of a tape.
- **Two-motor full-logic tape transport:** For comfortable operation.
- **Dolby B/C noise reduction:** For low-noise recording standby.
- **Music Search:** To find the song you want quickly.
- **Rec mute:** Adds silences between recorded songs.
- **One-touch recording standby.**
- **LED level meters, one for each channel.**
- **Timer record/play (timer optional).**
- **Pioneer SR (System Remote) ready for hands-off operation.**

SPEAKER SYSTEMS

LDMC — Linear-Drive Magnetic Circuit

To make a speaker system truly ready for digital programs, simply expanding frequency range and reducing distortion isn't enough. Linearity must also be improved to effectively expand the system's dynamic range. Our search for the best way to combine these properties in a speaker system without increasing its size led to a new design we call the LDMC (Linear-Drive Magnetic Circuit).

The woofer diaphragm must travel over a relatively long distance to produce sound over a wide level range. The power to drive the woofer results from an interaction between the current flowing through its voice coil and the magnetic flux created by its magnet. Ideally, that driving power should change linearly. But in conventional magnetic circuits, the magnetic flux isn't distributed uniformly; accordingly, the driving force it creates does not change linearly. Loud sounds are not reproduced with the same accuracy and delicacy as soft sounds. The result? Distortion. To your ears, the sound seems lifeless and boring.

The new Linear-Drive Magnetic Circuit has dramatically improved linearity in our woofers. It creates a more uniform magnetic flux for the voice coil and hence a more linear force to drive the woofer diaphragm, regardless of the position of the diaphragm while in motion.

With linearity improved and distortion reduced dramatically, the sound from our LDMC woofers is refreshingly transparent, powerful and exceptionally lifelike. The precise performance of the woofer is further improved by a DRS (Dynamic Response Suspension) system that helps the diaphragm move in proportion to the level of the applied signal.

EBD — Electronic Bass Drive

The woofers in our DSS Series of speaker systems have another Pioneer-exclusive feature — EBD (Electronic Bass Drive). This design winds two voice coils on the bobbin, one over the other. To one an input with low frequencies is applied, while to the other the input with only ultra-low frequencies is applied. When reproducing music, the EBD effectively doubles the size of a speaker enclosure, thereby doubling the amount of usable low-frequency output you actually hear and enjoy. To further expand and improve the bass response, we've placed the woofer in a rear-ported bass-reflex enclosure.

Beryllium ribbon tweeter

In our ribbon tweeter featured in the DSS-9 and DSS-7, a thin ribbon of strong yet lightweight beryllium is employed as the diaphragm. Since the diaphragm generates and radiates sound directly, input signals are converted into acoustic energy accurately; in other words, linearity is far superior to other tweeter designs. And, because of its low mass and light weight, transient response is greatly improved. It all adds up to high-frequency sound that is delicate yet powerful, qualities that make our speaker systems perfect matches for digital programs.

Pioneer Polymer Graphite (PG) cones

Because a woofer has a larger diaphragm than other units in a speaker system, it is susceptible to speaker breakup, a phenomenon that occurs when various sections of the diaphragm begin to vibrate independently. Speaker breakup is a source of distortion. But our new Polymer Graphite (PG) diaphragm, featured in the DSS-9 and DSS-7, is so hard and firm, it doesn't break up as easily as paper. Yet unlike metals such as aluminum, it has excellent damping characteristics: response is smooth and free of peaks and dips over the entire frequency range assigned to the speaker. All in all, our PG diaphragm features very high power linearity with superior transient response, a rare combination that makes it ideal for digital reproduction.

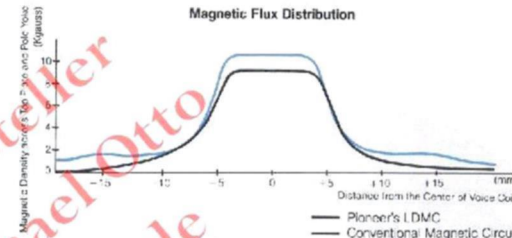
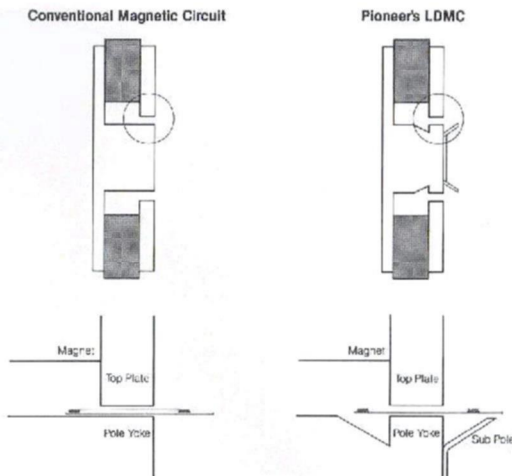

Working Principle of EBD Woofer

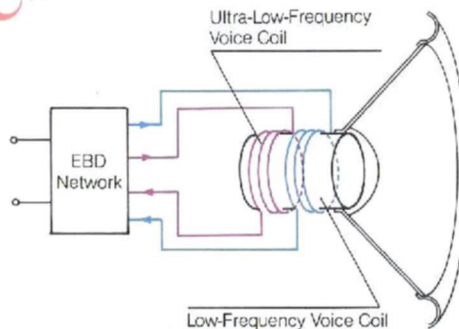

*Polymer Graphite is a trademark of Pioneer Electronics.



DSS-9

DSS-9



3-Way Bass Reflex Speaker System

- **12-inch (30cm) PG cone woofer:** Provides excellent transient response and reduces distortion.
- **4-3/4-inch (12cm) boron cone midrange:** Offers improved frequency response and extended dynamic range.
- **Pioneer beryllium ribbon tweeter:** For improved transient response and reduced distortion.
- **Linear-Drive Magnetic Circuit:** For accuracy and wide dynamic range from the loudest to the softest sound.
- **Electronic Bass Drive:** To extend bass response.
- **Round cornered baffle:** For clearer stereo imaging.
- **Tone selectors for mids and highs.**
- **High power, 240 watts (max music power), 80 watts (rated).**

DSS-7



3-Way Bass Reflex Speaker System

- **12-inch (30cm) PG cone woofer :** Provides excellent transient response and reduces distortion.
- **2-1/2-inch (6.6cm) boron cone midrange:** Offers improved frequency response and extended dynamic range.
- **Pioneer beryllium ribbon tweeter:** For improved transient response and reduced distortion.
- **Linear-Drive Magnetic Circuit:** For accuracy and wide dynamic range from the loudest to the softest sound.
- **Electronic Bass Drive:** To extend bass response.
- **Tone selectors for mids and highs.**
- **High power, 210 watts (max music power), 70 watts (rated).**



DSS-7

DSS-5

3-Way Bass Reflex Speaker System

- **3-way bass reflex design:** 10-inch (25cm) cone woofer, 2-1/2-inch (6.6cm) cone midrange, 3/4-inch (2cm) dome tweeter.
- **Linear-Drive Magnetic Circuit:** For accuracy and wide dynamic range from the loudest to the softest sound.
- **Dynamic Response Suspension:** The woofer is suspended by a responsive damper so it can accurately respond to dynamic changes in the input level.
- **Electronic Bass Drive:** To extend bass response to the lowest frequencies while improving transient response.
- **High power, 120 watts (max music power), 40 watts (rated).**



DSS-5

DSS-9/7/5: Vinyl-covered cabinet is finished in simulated walnut grain, with particleboard rear panel.

CS-707

4-Way Bass Reflex Speaker System with 15-3/4-inch Woofer

- **Extra large 15-3/4-inch (40cm) woofer with EBD (Electronic Bass Drive):** Use of heat-resistant voice coil and a large strontium ferrite magnet assures powerful, efficient reproduction of crisp lows down to 30Hz.
- **4-3/4-inch (12cm) cone midrange:** Equipped with a large strontium ferrite magnet for high power and forward sound.
- **Horn tweeter:** An acoustic lens provides well-dispersed highs for excellent definition. A self-restoring protection circuit prevents voice coil burnout.
- **Twin piezo supertweeters:** Extend high-frequency response beyond the audible range to ensure power and realism.
- **Three tone selectors (NORMAL, SOFT and CRISP):** Choose the position that's best for each type of music.
- **11-LED power indicators:** Show input level and warn of imminent overload.
- **Wide frequency response:** From 30Hz to 25,000Hz; high power capability, 300 watts max.



CS-707

CS-607

4-Way Bass Reflex Speaker System with 12-inch Woofer

- **Large 12-inch (30cm) woofer with EBD (Electronic Bass Drive):** Pioneer's exclusive EBD and large, powerful magnet provide crisp and gutsy lows down to 35Hz.
- **4-3/4-inch (12cm) cone midrange:** Equipped with a large strontium ferrite magnet for high power and forward sound.
- **Horn tweeter:** An acoustic lens provides well-dispersed highs for excellent definition. A self-restoring protection circuit prevents voice coil burnout.
- **Twin piezo supertweeters:** Extend high-frequency response beyond the audible range to ensure power and realism.
- **11-LED power indicators:** Show input level and warn of imminent overload.
- **Wide frequency response:** From 35Hz to 25,000Hz; high power capability, 210 watts max.



CS-607

CS-407

3-Way Bass Reflex Speaker System with 12-inch Woofer

- **High-power 12-inch (30cm) woofer:** High-efficiency magnetic circuit permits the unit to handle high power levels for robust bass.
- **4-inch (10cm) cone midrange:** Designed for high efficiency and power to reproduce authentic presence.
- **2-1/2-inch (6.6cm) cone tweeter:** An acoustic lens provides well-dispersed highs for excellent definition.
- **Wide frequency response:** From 35Hz to 20,000Hz; high power capability, 150 watts max.



CS-407



CS-G301WAI

CS-G301WAI

3-Way Bass Reflex Speaker System with 12-inch Woofer

- **Large 12-inch (30cm) woofer:** Provided with a highly efficient magnet for powerful reproduction of lows.
- **4-3/4-inch (12cm) cone midrange:** For accurate, clean mids.
- **2-1/2-inch (6.6cm) cone tweeter:** For efficient reproduction of extending highs.
- **Wide frequency response:** From 35Hz to 20,000Hz; high power capability, 120 watts (max music power).

CS-G201WAI

3-Way Bass Reflex Speaker System with 10-inch Woofer

- **Large 10-inch (25cm) woofer:** Provided with a highly efficient magnet for powerful reproduction of lows.
- **3-inch (7.7cm) cone midrange:** For accurate, clean mids.
- **2-1/2-inch (6.6cm) cone tweeter:** For efficient reproduction of brilliant highs.
- **Wide frequency response:** From 40Hz to 20,000Hz; high power capability, 100 watts (max music power).

CS-G101WAI

2-Way Bass Reflex Speaker System with 10-inch Woofer

- **Large 10-inch (25cm) woofer:** Provided with a highly efficient magnet for powerful reproduction of lows.
- **2-1/2-inch (6.6cm) cone tweeter:** For efficient reproduction of brilliant highs.
- **Wide frequency response:** From 55Hz to 20,000Hz; high power capability, 50 watts (max music power).



CS-G201WAI



CS-G101WAI



S-X7

S-X7

Surround Speaker System

- **Compact and lightweight** (3 lbs. 5 oz./1.5kg)
- **Wide installation versatility:** Can be hung on the wall or from the ceiling for stereo or surround sound
- **3-1/2-inch (8.7cm) full-range speaker.**
- **30 watts (max music power).**



CS-G301WAI/G201WAI/G101WAI:
Vinyl-covered cabinet is finished in
simulated walnut grain, with par-
ticleboard rear panel.

ADD-ON EQUIPMENT



GR-777

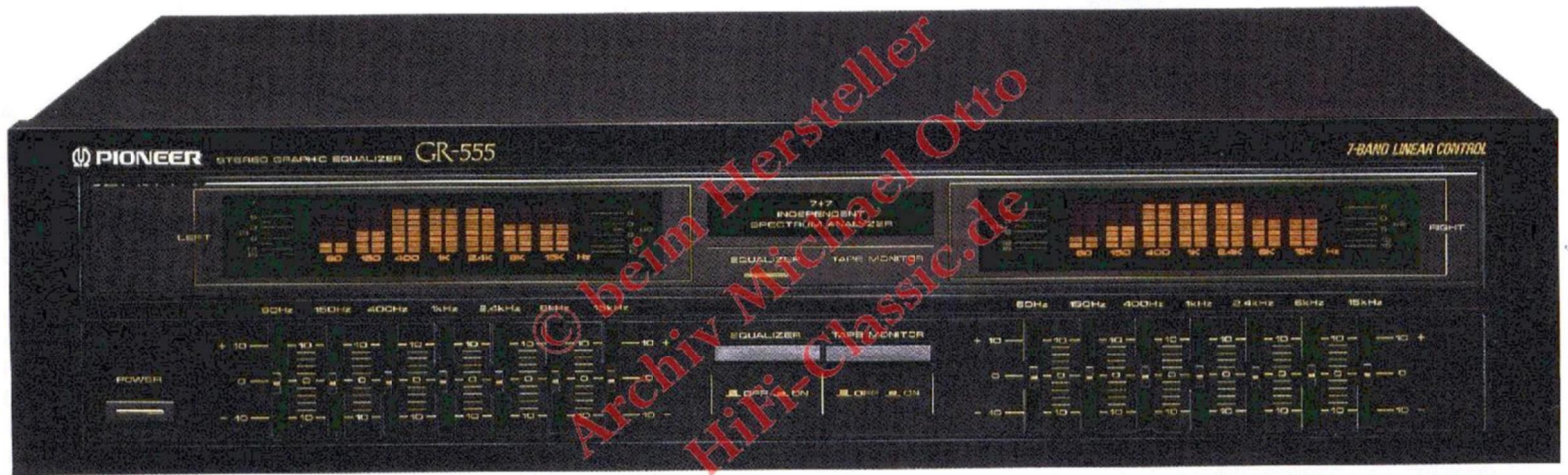

GR-555

GR-777



Electronic 10-Band Graphic Equalizer

- **10-band equalization:** Boost and cut up to 10dB at 10 frequency bands — 32Hz, 63Hz, 125Hz, 250Hz, 500Hz, 1kHz, 2kHz, 4kHz, 8kHz, 16kHz — channel by channel.
- **10-band spectrum analyzer:** Monitors the frequency makeup of music, channel by channel.
- **5 programmable equalization patterns:** Create your own equalized curves and store them in memory.
- **5 resident equalization patterns:** Five equalized curves — called HEAVY, CLEAR, SOFT, VISUAL and VOCAL — are stored in memory for instant recall.
- **SR remote control supplied.**

GR-470

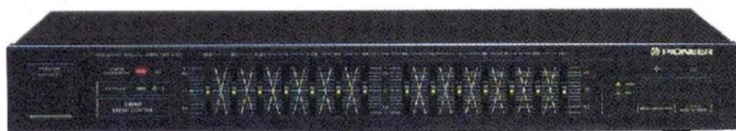

GR-555

7-Band Graphic Equalizer

- **7-band equalization:** Permits boost and cut up to 10dB at 7 frequency bands — 60Hz, 150Hz, 400Hz, 1kHz, 2.4kHz, 6kHz and 15kHz — channel by channel.
- **7-band spectrum analyzer:** Monitors the frequency makeup of music, channel by channel.
- **Tape monitor.**
- **Equalizer on/off switch.**

GR-470

7-Band Graphic Equalizer

- **7-band equalization:** Permits boost and cut up to 10dB at 7 frequency bands — 60Hz, 150Hz, 400Hz, 1kHz, 2.4kHz, 6kHz and 15kHz — channel by channel.
- **LEDs in slider tips:** Depict the "shape" of response you've created, channel by channel.
- **Equalizer on/off switch.**

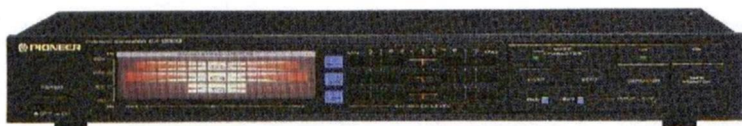

EX-9000

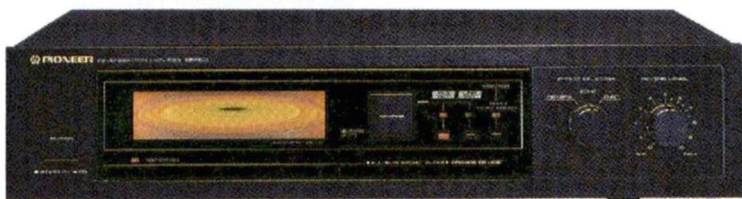

SR-60

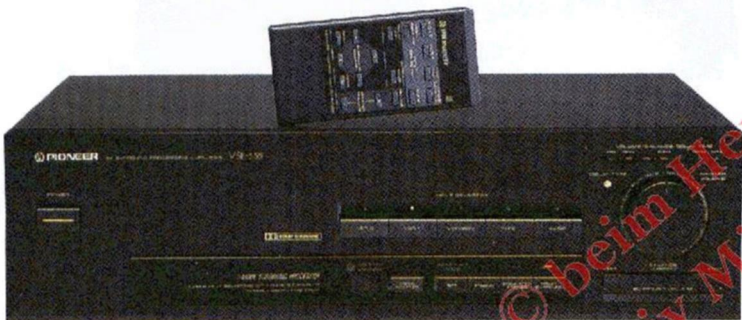

VSP-555

CU-AV100



CU-AV70

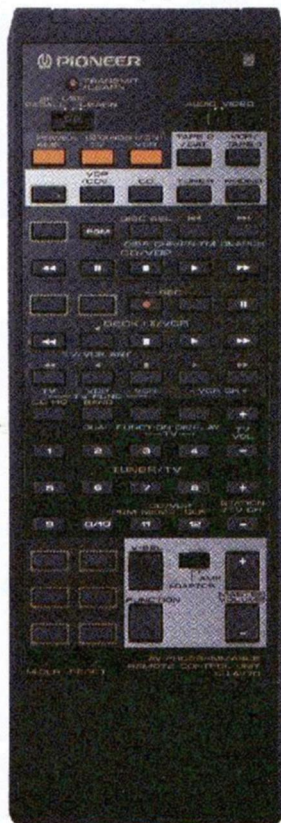

EX-9000

Dynamic Expander

- **Dynamic expansion:** Increases overall dynamic range of any music source to match digital's.
- **3-band adjustment:** Expansion level is adjustable band by band — lows, mids and highs.
- **"Music Character" buttons:** "HARD" for very dynamic programs, "SOFT" for programs with little dynamic variation.
- **Fluorescent expansion indicator:** Attractive two-color design, and divided band by band for convenience.
- **Noise reduction:** Noise in any program material can be reduced.
- **Two input levels:** 0dB and -6dB, the latter to prevent distortion due to an excessively high input signal.

SR-60

Reverberation Amplifier

- **Effect selector:** Three positions are offered.
REVERB — Turns a listening room into a concert hall.
ECHO — Applies echo to all signals.
DUET — Makes a solo singer sound like a duo.
- **Reverb level control:** Continuously adjusts the reverb time over 0 to 3 second range.
- **BBD (Bucket Brigade Device) amp:** For natural, low-distortion application of reverberation.
- **Time/depth display:** Shows the amount of reverb as a pleasing visual effect.
- **Reverb recording:** Allows you to record music with reverb added.
- **Line output.**

VSP-555

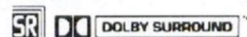

Digital Surround Processing Amplifier

- **3-mode surround processor:** DOLBY, STADIUM and SIMULATED modes provide exciting surround sound.
- **Low-distortion digital delay:** Delay time can be set for 15, 20 or 30msec.
- **Versatile audio/video switching and connections:** 1 tape deck, 2 VCRs, 1 LD player, 1 monitor TV, 1 video adaptor, and surround speakers can be connected. There are also outputs for a center-channel amp and a front-channel amp. Two-way dubbing is possible between VCR-1 and VCR-2.
- **Built-in power amp for surround:** Continuous average power output of 30 watts* per channel, min., at 8 ohms, from 30Hz to 7kHz with no more than 5% total harmonic distortion. (Dolby Surround on)
- **Independent selection of audio and video programs.**
- **SR remote control supplied.**

*Measured pursuant to the Federal Trade Commission's Trade Regulation Rule on Power Output Claims for Amplifiers.

CU-AV100/CU-AV70



Smart Remotes™

Our Smart Remote™ is what its name implies — smart. It does more than operate audio and video components, with Pioneer SR (System Remote): you can program its functions as you like. It has the capacity to learn functions from other remote controls for most audio or video components so long as they are of the infrared type. So with our Smart Remote in hand, you can handle just about every audio and video operation from the comfort of your chair. The CU-AV100 has 68 keys to offer 225 functions (max.), of which 154 are programmable, while the CU-AV70 provides 65 keys for 170 functions (max.), of which 40 are programmable.

*With infrared remote control units of other make that use special signal types, programming functions may not be possible.

TURNTABLES

PL-910



Front-Loading Programmable Linear Tracking Turntable

- **Programming of up to 8 tracks:** You can program the turntable to play a total of 8 songs (15 if some are repeated) on a record in any order.
- **Pioneer-exclusive Dynamic Resonance Absorber (DRA) on tone arm:** A result of computer vibration analyses, this complex resonator eliminates resonance-induced vibration, adding clarity to sound.
- **Front-loading design:** For stack-up mounting ease.
- **Linear tracking:** Reduces tracking error for lower distortion and better definition.
- **Automatic disc size/speed selector:** Record size and speed are automatically chosen by an optical sensor.
- **Touch controls:** Positioned outside the cabinet for easy operation.
- **Manual cueing controls:** Permit precise cueing of tone arm to any position, left or right.
- **Repeat:** For play of a record up to 8 times.



PL-910

PL-L550



Fully Automatic Linear Tracking Turntable

- **Pioneer-exclusive Dynamic Resonance Absorber (DRA) on tone arm:** A result of computer vibration analyses, this complex resonator eliminates resonance-induced vibration, adding clarity to sound.
- **Linear tracking:** Reduces tracking error for lower distortion and better definition.
- **Coreless FG-servo direct-drive motor:** For smooth and stable platter rotation. Pioneer Stable Hanging Rotor reduces spindle wobble.
- **Automatic disc size/speed selector:** Record size and speed are automatically chosen by an optical sensor.
- **Repeat:** For play of a record up to 8 times.
- **T4P-mount plug-in cartridge connector.** (Cartridge not included)

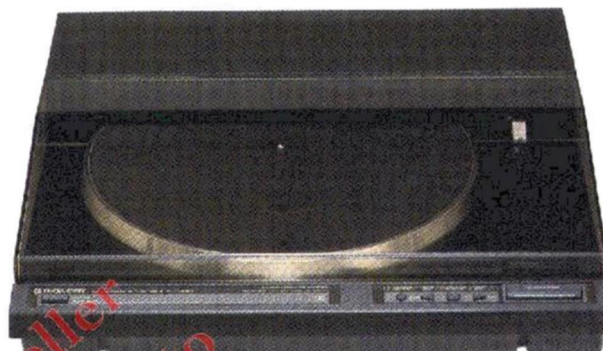

PL-L550

PL-670



Fully Automatic Direct-Drive Turntable

- **Pioneer-exclusive Dynamic Resonance Absorber (DRA) on tone arm:** A result of computer vibration analyses, this complex resonator eliminates resonance-induced vibration, adding clarity to sound.
- **DC-servo direct-drive motor with Stable Hanging Rotor:** Provides smooth and accurate platter rotation. Stable Hanging Rotor adds dynamic stability to the rotating motor.
- **Automatic record size selector.**
- **Front operation.**
- **T4P-mount plug-in cartridge connector.** (Cartridge not included)
- **Cueing control.**



PL-670

PL-590

Fully Automatic Turntable

- **Fully automatic operation:** For easy hands-off use.
- **Low-mass straight tone arm:** Ensures accurate, low-distortion disc playback.
- **High-performance DC-servo motor with Stable Hanging Rotor:** Platter rotation is precise and stable with the Stable Hanging Rotor improving dynamic stability.
- **Universal type cartridge connector:** An MM cartridge is mounted.

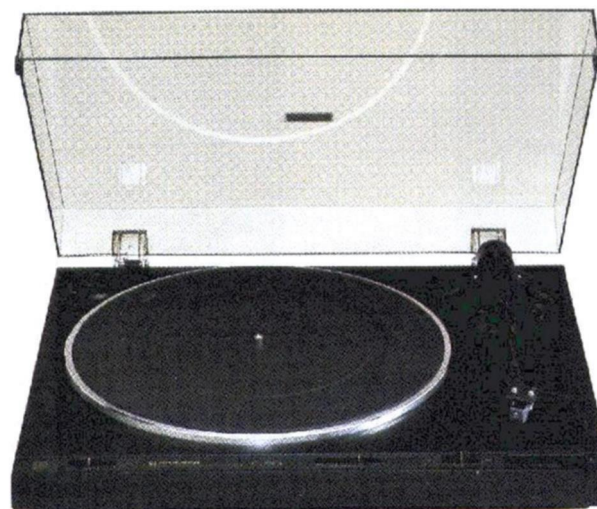

PL-590

HI-FI ACCESSORIES

Whatever your setup, Pioneer has accessories designed to meet your needs. Our line of headphones offers models for any application — private listening, portable listening, and monitoring. Each provides superb sound reproduction and is structured for comfortable, fatigue-free listening.

Pioneer microphones offer natural, balanced response, wide frequency range, and clear, crisp sound. They're rugged enough to survive rough handling, and are easy to use.

Pioneer's line of cartridges is just as comprehensive: there's an MC (Moving-Coil) cartridge with high output so you can connect the turntable directly to the normal phono inputs of your amp. We also offer a number of T4P-mount plug-in cartridges for easy installation.

CARTRIDGES & STYLI



PN-5MC PC-5MC
Low-mass high-output MC cartridge



PN-300T PC-300T
Plug-in (T4P) MM cartridge



PN-295T PC-295T
Plug-in (T4P) MM cartridge



PN-290T PC-290T
Plug-in (T4P) MM cartridge



PN-250T PC-250T
Plug-in (T4P) MM cartridge



PN-240
Replacement stylus



SE-M90
Stereo Headphones



SE-M70
Stereo Headphones



SE-M50
Stereo Headphones



SE-50D
Stereo Headphones



SE-205
Stereo Headphones



SE-30D
Stereo Headphones



DM-61
Dynamic Microphone



DM-51
Dynamic Microphone



DM-21
Dynamic Microphone



This is a standard logo mark for the plug-in cartridge connector system. Any cartridges carrying this mark are compatible with any turntables or tone arms carrying the same mark.

SPECIFICATIONS

RECEIVERS

	VSX-9300S	VSX-7300	VSX-5300	VSX-3300/VSX-3300S	SX-2300	SX-1300
AMPLIFIER SECTION						
Continuous Power Output Stereo Mode:	Continuous average power output of 125 watts* per channel, min., at 8 ohms from 20Hz to 20,000Hz with no more than 0.005% total harmonic distortion	Continuous average power output of 125 watts* per channel, min., at 8 ohms from 20Hz to 20,000Hz with no more than 0.005% total harmonic distortion	Continuous average power output of 100 watts* per channel, min., at 8 ohms from 20Hz to 20,000Hz with no more than 0.005% total harmonic distortion	Continuous average power output of 80 watts* per channel, min., at 8 ohms from 20Hz to 20,000Hz with no more than 0.05% total harmonic distortion	Continuous average power output of 60 watts* per channel, min., at 8 ohms from 20Hz to 20,000Hz with no more than 0.07% total harmonic distortion	Continuous average power output of 40 watts* per channel, min., at 8 ohms from 20Hz to 20,000Hz with no more than 0.07% total harmonic distortion
Surround Mode Front Channels:	Continuous average power output of 125 watts* per channel, min., at 8 ohms from 20Hz to 20,000Hz with no more than 0.005% total harmonic distortion	Continuous average power output of 125 watts* per channel, min., at 8 ohms from 20Hz to 20,000Hz with no more than 0.005% total harmonic distortion	Continuous average power output of 100 watts* per channel, min., at 8 ohms from 20Hz to 20,000Hz with no more than 0.005% total harmonic distortion	Continuous average power output of 80 watts* per channel, min., at 8 ohms from 20Hz to 20,000Hz with no more than 0.05% total harmonic distortion	Continuous average power output of 60 watts* per channel, min., at 8 ohms from 20Hz to 20,000Hz with no more than 0.07% total harmonic distortion	Continuous average power output of 40 watts* per channel, min., at 8 ohms from 20Hz to 20,000Hz with no more than 0.07% total harmonic distortion
Rear Channels:	Continuous average power output of 30 watts per channel, min., at 8 ohms at 1kHz with no more than 0.7% total harmonic distortion	Continuous average power output of 30 watts per channel, min., at 8 ohms at 1kHz with no more than 0.7% total harmonic distortion	Continuous average power output of 30 watts per channel, min., at 8 ohms at 1kHz with no more than 0.7% total harmonic distortion	Continuous average power output of 15 watts per channel, min., at 8 ohms at 1kHz with no more than 0.7% total harmonic distortion	Continuous average power output of 15 watts per channel, min., at 8 ohms at 1kHz with no more than 0.7% total harmonic distortion	Continuous average power output of 15 watts per channel, min., at 8 ohms at 1kHz with no more than 0.7% total harmonic distortion
Dynamic Power (2/4/8 ohms):	280/260/185W	280/260/185W	230/200/150W	190/165/120W	145/125/85W	—/90/65W
Total Harmonic Distortion: (8 ohms)	0.005% (20—20,000Hz, continuous rated power output)	0.005% (20—20,000Hz, continuous rated power output)	0.005% (20—20,000Hz, continuous rated power output)	0.05% (20—20,000Hz, continuous rated power output)	0.07% (20—20,000Hz, continuous rated power output) 0.01% (1,000Hz, 60W per channel power output)	0.07% (20—20,000Hz, continuous rated power output) 0.01% (1,000Hz, 40W per channel power output)
Input Sensitivity/Impedance PHONO (MM): CD, AUX, TAPE, ADAPTOR: VCR, VDP:	2.5mV/47k ohms 150mV/47k ohms 150mV/47k ohms	2.5mV/47k ohms 150mV/47k ohms 150mV/47k ohms	2.5mV/47k ohms 150mV/47k ohms 150mV/47k ohms	2.5mV/47k ohms 150mV/22k ohms 150mV/22k ohms	2.5mV/47k ohms 150mV/22k ohms 150mV/22k ohms	2.5mV/47k ohms 150mV/22k ohms 150mV/22k ohms
PHONO Overload Level (1kHz) MM:	150mV (T.H.D. 0.08%)	150mV (T.H.D. 0.08%)	130mV (T.H.D. 0.08%)	130mV (T.H.D. 0.01%)	130mV (T.H.D. 0.01%)	130mV (T.H.D. 0.01%)
Output Level/Impedance TAPE REC: VCR REC: PRE OUT:	150mV/2.2k ohms 150mV/2.2k ohms 1V/220 ohms	150mV/2.2k ohms 150mV/2.2k ohms 1V/220 ohms	150mV/2.2k ohms 150mV/2.2k ohms —	150mV/2.2k ohms 150mV/2.2k ohms —	150mV/2.2k ohms — —	150mV/2.2k ohms — —
Frequency Response PHONO (RIAA Equalization): CD, AUX, TAPE: VCR, VDP:	20—20,000Hz ±0.3dB 5—100,000Hz 0dB, -3dB 5—100,000Hz 0dB, -3dB	20—20,000Hz ±0.3dB 5—100,000Hz 0dB, -3dB 5—100,000Hz 0dB, -3dB	20—20,000Hz ±0.3dB 5—100,000Hz 0dB, -3dB 5—100,000Hz 0dB, -3dB	20—20,000Hz ±0.5dB 10—70,000Hz +0.5dB, -3dB 10—70,000Hz +0.5dB, -3dB	20—20,000Hz ±0.5dB 10—70,000Hz +0.5dB, -3dB 10—70,000Hz +0.5dB, -3dB	20—20,000Hz ±0.5dB 10—70,000Hz +0.5dB, -3dB 10—70,000Hz +0.5dB, -3dB
Tone Control BASS: TREBLE:	±8dB (100Hz) ±8dB (10kHz)	±8dB (100Hz) ±8dB (10kHz)	±8dB (100Hz) ±8dB (10kHz)	— —	— —	— —
Graphic Equalizer Equalizer Range: Center Frequencies:	— —	— —	— —	±8dB 100, 330, 1k, 3.3k, 10kHz	±8dB 100, 330, 1k, 3.3k, 10kHz	±8dB 100, 330, 1k, 3.3k, 10kHz
VCR Noise Filter Low: High:	-3dB (100Hz) -3dB (5kHz)	-3dB (100Hz) -3dB (5kHz)	-3dB (100Hz) -3dB (5kHz)	— —	— —	— —
Loudness Contour:	+6dB (100Hz), +3dB (10kHz)	+6dB (100Hz), +3dB (10kHz)	+6dB (100Hz), +3dB (10kHz)	—	—	—
Signal-to-Noise Ratio (IHF '66/EIA) PHONO (MM): CD, AUX, TAPE: VCR, VDP:	82dB/77dB 98dB/80dB 98dB/80dB	82dB/77dB 98dB/80dB 98dB/80dB	82dB/77dB 98dB/80dB 98dB/80dB	73dB/75dB 96dB/79dB 96dB/79dB	72dB/75dB 97dB/80dB 97dB/80dB	72dB/75dB 97dB/80dB 97dB/80dB
FM TUNER SECTION						
Usable Sensitivity (mono):	10.8dBf (0.95µV, 75 ohms)	10.8dBf (0.95µV, 75 ohms)	10.8dBf (0.95µV, 75 ohms)	10.8dBf (0.95µV, 75 ohms)	10.8dBf (0.95µV, 75 ohms)	10.8dBf (0.95µV, 75 ohms)
50dB Quieting Sensitivity Mono: Stereo:	15.3dBf (1.6µV, 75 ohms) 37.1dBf (19.5µV, 75 ohms)	15.3dBf (1.6µV, 75 ohms) 37.1dBf (19.5µV, 75 ohms)	15.3dBf (1.6µV, 75 ohms) 37.1dBf (19.5µV, 75 ohms)	15.3dBf (1.6µV, 75 ohms) 37.1dBf (19.5µV, 75 ohms)	15.3dBf (1.6µV, 75 ohms) 37.1dBf (19.5µV, 75 ohms)	15.3dBf (1.6µV, 75 ohms) 37.1dBf (19.5µV, 75 ohms)
Signal-to-Noise Ratio Mono: Stereo:	80dB (at 85dBf) 76dB (at 85dBf)	80dB (at 85dBf) 76dB (at 85dBf)	80dB (at 85dBf) 76dB (at 85dBf)	80dB (at 85dBf) 76dB (at 85dBf)	79dB (at 85dBf) 75dB (at 85dBf)	78dB (at 85dBf) 75dB (at 85dBf)
Distortion 100Hz (mono/stereo): 1kHz (mono/stereo): 6kHz (mono/stereo):	0.08%/0.2% 0.08%/0.15% 0.2%/0.3%	0.08%/0.2% 0.08%/0.15% 0.2%/0.3%	0.08%/0.2% 0.08%/0.15% 0.2%/0.3%	0.2%/0.3%	0.2%/0.3%	0.2%/0.3%
Frequency Response:	30—15,000Hz +0.5dB, -2dB	30—15,000Hz +0.5dB, -2dB	30—15,000Hz +0.5dB, -2dB	30—15,000Hz ±1dB	30—15,000Hz ±1dB	30—15,000Hz ±1dB
Capture Ratio:	1.0dB	1.0dB	1.0dB	1.2dB	1.2dB	1.2dB
Alternate Channel Selectivity:	65dB (400kHz)	65dB (400kHz)	65dB (400kHz)	55dB (400kHz)	55dB (400kHz)	55dB (400kHz)
Stereo Separation 1kHz: 30—15,000Hz:	50dB 35dB	50dB 35dB	48dB	35dB	35dB	35dB
Antenna Input:	300 ohms balanced 75 ohms unbalanced	300 ohms balanced 75 ohms unbalanced	300 ohms balanced 75 ohms unbalanced	300 ohms balanced 75 ohms unbalanced	300 ohms balanced 75 ohms unbalanced	300 ohms balanced 75 ohms unbalanced
AM TUNER SECTION						
Sensitivity (IHF, Loop Antenna): (IHF, External Antenna):	300µV/m 20µV	300µV/m 20µV	300µV/m 20µV	300µV/m 20µV	300µV/m 20µV	300µV/m 20µV
Selectivity:	30dB	30dB	30dB	25dB	20dB	20dB
Signal-to-Noise Ratio:	50dB	50dB	50dB	50dB	50dB	50dB
Antenna:	Loop antenna	Loop antenna	Loop antenna	Loop antenna	Loop antenna	Loop antenna

*Measured pursuant to the Federal Trade Commission's Trade Regulation Rule on Power Output Claims for Amplifiers.

	VSX-9300S	VSX-7300	VSX-5300	VSX-3300/VSX-3300S	SX-2300	SX-1300
VIDEO SECTION						
Input (Sensitivity/Impedance) VCR, VDP:	1Vp-p/75 ohms	1Vp-p/75 ohms	1Vp-p/75 ohms	1Vp-p/75 ohms	—	—
Output (Level/Impedance) VCR, VDP, Monitor:	1Vp-p/75 ohms	1Vp-p/75 ohms	1Vp-p/75 ohms	1Vp-p/75 ohms	—	—
Frequency Response:	5Hz—10MHz 0dB, -3dB	5Hz—10MHz 0dB, -3dB	5Hz—10MHz 0dB, -3dB	10Hz—6MHz +1dB, -2dB	—	—
Crosstalk:	55dB (3.58MHz)	55dB (3.58MHz)	55dB (3.58MHz)	55dB (3.58MHz)	—	—
Enhancer:	±3dB (2MHz)	±3dB (2MHz)	±3dB (2MHz)	—	—	—
Signal-to-Noise Ratio:	55dB	55dB	55dB	50dB	—	—
MISCELLANEOUS						
Power Requirements:	120V 60Hz	120V 60Hz	120V 60Hz	120V 60Hz	120V 60Hz	120V 60Hz
Power Consumption:	550W (UL), 3W (standby)	550W (UL), 3W (standby)	415W (UL), 3W (standby)	475W (UL), 3W (standby)	315W (UL)	175W (UL)
Dimensions (W x H x D): (without package)	16-9/16 x 6-1/8 x 16-9/16 inches 420 x 155.5 x 421 mm	16-9/16 x 6-1/8 x 16-9/16 inches 420 x 155.5 x 421 mm	16-9/16 x 4-7/8 x 15-13/16 inches 420 x 124 x 401 mm	16-9/16 x 4-3/4 x 13-1/4 inches 420 x 120 x 337 mm	16-9/16 x 4-3/4 x 13-1/4 inches 420 x 120 x 337 mm	16-9/16 x 4-3/4 x 13-1/4 inches 420 x 120 x 337 mm
Weight (without package):	26 lbs. 8 oz./12kg	26 lbs. 8 oz./12kg	22 lbs. 1 oz./10kg	18 lbs. 1 oz./8.2kg	15 lbs. 7 oz./7.0kg	13 lbs. 11 oz./6.2kg

COMPACT DISC PLAYERS

	PD-M700	PD-M600	PD-M500	PD-M400
System:	Compact disc digital audio system	Compact disc digital audio system	Compact disc digital audio system	Compact disc digital audio system
Frequency Response:	4—20,000Hz ±0.5dB	4—20,000Hz ±0.5dB	4—20,000Hz ±0.5dB	4—20,000Hz ±0.5dB, -1.0dB
Signal-to-Noise Ratio (EIAJ):	104dB	104dB	102dB	102dB
Dynamic Range (EIAJ):	96dB	96dB	92dB	92dB
Channel Separation (EIAJ):	100dB	100dB	95dB	95dB
Wow and Flutter (EIAJ):	Unmeasurable (±0.001%, weighted peak)	Unmeasurable (±0.001%, weighted peak)	Unmeasurable (±0.001%, weighted peak)	Unmeasurable (±0.001%, weighted peak)
Distortion (EIAJ):	0.003%	0.004%	0.03%	0.05%
Output Voltage (EIAJ):	2.2V ±0.3V	2.2V ±0.3V	2.0V ±0.3V	1.8V ±0.3V
Power Requirement:	120V 60Hz	120V 60Hz	120V 60Hz	120V 60Hz
Power Consumption:	18W	16W	13W	11W
Dimensions (W x H x D): (without package)	16-9/16 x 4-5/16 x 12-3/8 inches 420 x 109 x 315 mm	16-9/16 x 4-5/16 x 12-3/8 inches 420 x 109 x 315 mm	16-9/16 x 3-9/16 x 12-3/8 inches 420 x 90 x 315 mm	16-9/16 x 3-9/16 x 12-3/8 inches 420 x 90 x 315 mm
Weight (without package):	11 lbs. 14 oz./5.4kg	11 lbs. 11 oz./5.3kg	10 lbs. 13 oz./4.9kg	10 lbs. 6 oz./4.7kg

	PD-7100	PD-5100	PD-4100
System:	Compact disc digital audio system	Compact disc digital audio system	Compact disc digital audio system
Frequency Response:	4—20,000Hz ±0.5dB	4—20,000Hz ±0.5dB	4—20,000Hz ±0.5dB, -1.0dB
Signal-to-Noise Ratio (EIAJ):	107dB	102dB	102dB
Dynamic Range (EIAJ):	97dB	92dB	92dB
Channel Separation (EIAJ):	100dB	95dB	95dB
Wow and Flutter (EIAJ):	Unmeasurable (±0.001%, weighted peak)	Unmeasurable (±0.001%, weighted peak)	Unmeasurable (±0.001%, weighted peak)
Distortion (EIAJ):	0.0025%	0.03%	0.05%
Output Voltage (EIAJ):	2.0V ±0.5V	2.0V ±0.3V	1.8V ±0.3V
Power Requirement:	120V 60Hz	120V 60Hz	120V 60Hz
Power Consumption:	11W	13W	11W
Dimensions (W x H x D): (without package)	16-9/16 x 4-13/16 x 12-3/8 inches 420 x 123 x 315 mm	16-9/16 x 3-7/8 x 12-3/8 inches 420 x 98 x 315 mm	16-9/16 x 3-9/16 x 12-3/8 inches 420 x 90 x 315 mm
Weight (without package):	12 lbs. 9 oz./5.7kg	8 lbs. 10 oz./3.9kg	8 lbs. 6 oz./3.8kg

AMPLIFIERS

	A-717	VSA-910
AMPLIFIER SECTION		
Continuous Power Output:	Continuous average power output of 100 watts* per channel, min., at 8 ohms from 20Hz to 20,000Hz with no more than 0.003% total harmonic distortion, or 135 watts* per channel, min., at 4 ohms from 20Hz to 20,000Hz with no more than 0.005% total harmonic distortion	Continuous average power output of 100 watts* per channel, min., at 8 ohms from 20Hz to 20,000Hz with no more than 0.005% total harmonic distortion SURROUND MODE (Front channels) Continuous average power output of 70 watts* per channel, min., at 8 ohms from 20Hz to 20,000Hz with no more than 0.005% total harmonic distortion (Rear channels) Continuous average power output of 30 watts* per channel, min., at 8 ohms from 20Hz to 20,000Hz with no more than 0.08% total harmonic distortion
Total Harmonic Distortion:	0.003% (20—20,000Hz, 8 ohms, continuous rated power output) 0.005% (20—20,000Hz, 6 ohms, continuous rated power output)	0.005% (20—20,000Hz, continuous rated power output)
Intermodulation Distortion: (5CHz:7,000Hz=4:1, 8 ohms)	0.003% (continuous rated power output)	
Input Sensitivity/Impedance PHONO (MM): PHONO (MC): CD, AUX, TAPE, ADAPTOR: VCR, VDP:	2.5mV/50k ohms 0.2mV/100 ohms 150mV/50k ohms —	2.5mV/50k ohms — 150mV/30k ohms 150mV/30k ohms
PHONO Overload Level (1kHz) MM/MC:	200mV/19mV (T.H.D. 0.008%)	150mV (T.H.D. 0.03%)
Output Level/Impedance TAPE REC: VCR, VDP: PRE OUT: SPEAKERS: HEADPHONES:	150mV/2.2k ohms — — A, B, A+B, OFF Low impedance	150mV/4.7k ohms 150mV/4.7k ohms 1V/470 ohms A, B, A+B, OFF Low impedance
Frequency Response PHONO (RIAA Equalization) MM: MC: CD, AUX, TAPE: VCR, VDP:	20—20,000Hz ±0.2dB 20—20,000Hz ±0.3dB 1—150,000Hz 0dB, -3dB —	20—20,000Hz ±0.3dB 5—100,000Hz 0dB, -3dB 5—100,000Hz 0dB, -3dB
Tone Control BASS: TREBLE:	±8dB (100Hz) ±8dB (10kHz)	±6dB (100Hz) ±8dB (10kHz)
Filter PHONO Subsonic Filter: VCR Noise Filter Low: High:	7Hz (-12dB/oct.) — — —	— 50Hz (-6dB/oct.) 5kHz (-6dB/oct.)
Loudness Contour: (Volume at -40dB position)	+5dB (100Hz), +3dB (10kHz)	+6dB (100Hz), +3dB (10kHz)
Signal-to-Noise Ratio (IHF, short-circuited A-network) PHONO (MM/MC): CD, AUX, TAPE: VCR, VDP:	— 95dB/77dB 108dB —	83dB/— 96dB 96dB
VIDEO SECTION		
Input (Sensitivity/Impedance) VCR, VDP, Adaptor:	—	1Vp-p/75 ohms unbalanced
Output (Level/Impedance) VCR, Adaptor, Monitor TV:	—	1Vp-p/75 ohms unbalanced
Frequency Response:	—	5Hz—6MHz 0dB, -3dB
Crosstalk:	—	55dB (3.58MHz)
Signal-to-Noise Ratio:	—	55dB
MISCELLANEOUS		
Power Requirements:	120V 60Hz	120V 60Hz
Power Consumption:	500W (UL)	420W (UL)
Dimensions (W x H x D): (without package)	16-9/16 x 6-5/16 x 16-11/16 inches 420 x 160 x 424 mm	16-9/16 x 4-7/8 x 15-9/16 inches 420 x 124 x 396 mm
Weight (without package):	41 lbs. 14 oz./19kg	24 lbs. 4 oz./11kg

*Measured pursuant to the Federal Trade Commission's Trade Regulation Rule on Power Output Claims for Amplifiers.

TUNERS

	F-717	F-551
FM TUNER SECTION		
Usable Sensitivity (mono):	10.8dBf (0.95µV, 75 ohms)	11.2dBf (1.0µV, 75 ohms)
50dB Quieting Sensitivity Mono: Stereo:	14.2dBf (1.4µV, 75 ohms) 35.9dBf (17µV, 75 ohms)	36.2dBf (17.7µV, 75 ohms)
Signal-to-Noise Ratio Mono: Stereo:	86dB (at 80dBf) 81dB (at 80dBf)	75dB (at 80dBf) 72dB (at 80dBf)
Distortion 100Hz (mono/stereo): 1kHz (mono/stereo): Mono/Stereo:	(at 80dBf) 0.05% / 0.08% 0.05% / 0.08% 0.05% (6kHz)/0.15% (10kHz)	—/0.4%
Frequency Response:	20—15,000Hz +0.4dB, -1dB	30—15,000Hz ±1dB
Capture Ratio:	1.0dB	1.5dB
Alternate Channel Selectivity:	56dB (400kHz)	65dB (400kHz)
Spurious Response Ratio:	70dB	
Image Response Ratio:	50dB	
IF Response Ratio:	90dB	
AM Suppression Ratio:	65dB	
Subcarrier Product Ratio:	60dB	
Muting Threshold:	25.2dBf (5µV, 75 ohms)	
Stereo Separation 1kHz: 20—10,000Hz:	60dB 50dB	40dB
Antenna Input:	300 ohms balanced 75 ohms unbalanced	300 ohms balanced 75 ohms unbalanced
AM TUNER SECTION		
Sensitivity IHF, Loop Antenna:	150µV/m	300µV/m
Selectivity:	40dB	20dB
Signal-to-Noise Ratio:	50dB	50dB
Image Response Ratio:	40dB	40dB
IF Response Ratio:	60dB	50dB
Antenna:	Loop antenna	Loop antenna
AUDIO SECTION		
Output (Level/Impedance) FM (100% Mod, Fixed): AM (30% Mod, Fixed):	650mV/1.4k ohms 150mV/1.4k ohms	650mV 150mV
MISCELLANEOUS		
Power Requirements:	120V 60Hz	120V 60Hz
Power Consumption:	9W	10W
Dimensions (W x H x D): (without package)	16-9/16 x 2-3/8 x 8-11/16 inches 420 x 61 x 221 mm	16-9/16 x 2-3/8 x 8-1/2 inches 420 x 60 x 215.8 mm
Weight (without package):	5 lbs. 2 oz./2.3kg	5 lbs. 8 oz./2.5kg

TURNTABLES

	PL-910	PL-L550	PL-670	PL-590
MOTOR				
Drive System:	Belt-drive	Direct-drive	Direct-drive	Belt-drive
Motor:	DC-servo motor	DC-servo motor	DC-servo motor	DC-servo motor
Speeds:	33-1/3 and 45 rpm	33-1/3 and 45 rpm	33-1/3 and 45 rpm	33-1/3 and 45 rpm
Wow and Flutter (WRMS):	0.06%	0.025%	0.025%	0.06%
Signal-to-Noise Ratio (DIN B):	70dB	80dB	78dB	68dB
TONE ARM				
Type:	Statically balanced, linear tracking tone arm with DRA	Statically balanced, linear tracking tone arm with DRA	Statically balanced, low mass straight PG™ tone arm with DRA	Statically balanced, straight tone arm
Effective Arm Length:	3-3/4 inches (95mm)	8-11/16 inches (221mm)	8-11/16 inches (221mm)	8-11/16 inches (221mm)
Overhang:	—	5/8 inch (15.5mm)	5/8 inch (15.5mm)	5/8 inch (15.5mm)
Usable Cartridge Weight:	Fixed	Fixed (T4P type)	Fixed (T4P plug-in)	4—8g
CARTRIDGE				
Type:	Integrated IM type (PC-291)	—	—	MM type
Frequency Response:	10—30,000Hz	—	—	10—30,000Hz
Output Voltage:	2.5mV	—	—	2.5mV
Stylus:	0.6 mil diamond (PN-291)	—	—	0.6 mil diamond (PN-240)
Tracking Force:	1.25g ± 0.25g	—	—	2.0—3.0g
MISCELLANEOUS				
Power Requirement:	120V 60Hz	120V 60Hz	120V 60Hz	120V 60Hz
Power Consumption:	11W	13W	9W	2W
Dimensions (W x H x D): (without package)	16-9/16 x 4-1/8 x 13-3/4 inches 420 x 105 x 350 mm	16-9/16 x 4-1/4 x 14-3/8 inches 420 x 108 x 365 mm	16-9/16 x 4-5/8 x 14-3/8 inches 420 x 118 x 365 mm	16-9/16 x 3-3/4 x 14 inches 420 x 95 x 356 mm
Weight (without package):	16 lbs. 8 oz./7.5kg	10 lbs. 9 oz./4.8kg	10 lbs. 6 oz./4.7kg	6 lbs. 3 oz./2.8kg

ADD-ON EQUIPMENT

GR-777

Inputs (Sensitivity/Impedance)	
LINE IN:	150mV/50k ohms
Outputs (Level/Impedance)	
LINE OUT:	150mV/3.3k ohms
Graphic Equalizer Section	
Equalizer Range:	±10dB
Center Frequencies:	32, 63, 125, 250, 500, 1k, 2k, 4k, 8k, 16kHz
Frequency Response	
LINE IN, TAPE PLAY:	5—70,000Hz +0dB, -3dB
Signal-to-Noise Ratio:	110dB
(IHF, A-network, output 1V)	
Total Harmonic Distortion:	0.02% (20—20,000Hz, output 1V)
Gain:	0dB
Spectrum Analyzer Section	
Display Resolution:	2dB (x 13)
Center Frequencies:	32, 63, 125, 250, 500, 1k, 2k, 4k, 8k, 16kHz
Miscellaneous	
Power Requirements:	120V 60Hz
Power Consumption:	18 watts
Dimensions (W x H x D):	16-9/16 x 3-3/8 x 12-1/4 inches 420 x 85.5 x 311.5 mm
Weight (without package):	8 lbs. 13 oz./4kg

GR-555

Inputs (Sensitivity/Impedance)	
LINE IN:	150mV/50k ohms
TAPE PLAY:	150mV/50k ohms
Outputs (Level/Impedance)	
LINE OUT:	150mV/2.2k ohms
Graphic Equalizer Section	
Equalizer Range:	±10dB
Center Frequencies:	60, 150, 400, 1k, 2.4k, 6k, 15kHz
Frequency Response	
LINE IN, TAPE PLAY:	10—50,000Hz +0dB, -3dB
Signal-to-Noise Ratio:	104dB
(IHF, A-network, output 1V)	
Total Harmonic Distortion:	0.03% (20—20,000Hz, output 1V)
Gain:	0dB (controls flat)
Spectrum Analyzer Section	
Display Resolution:	3dB (x 8)
Center Frequencies:	60, 150, 400, 1k, 2.4k, 6k, 15kHz
Miscellaneous	
Power Requirements:	120V 60Hz
Power Consumption:	16 watts
Dimensions (W x H x D):	16-9/16 x 4-1/8 x 13-1/8 inches 420 x 105 x 334 mm
Weight (without package):	9 lbs. 4 oz./4.2kg

GR-470

Equalizer Range:	±10dB
Center Frequencies:	60, 150, 400, 1k, 2.4k, 6k, 15kHz
Total Harmonic Distortion:	0.03% (20—20,000Hz, output 1V)
Gain:	0dB (controls flat)
Frequency Response:	5—50,000Hz 0dB, -3dB
Signal-to-Noise Ratio:	106dB (IHF, A-network, output 1V)
Input Sensitivity/Impedance:	150mV/50k ohms
Output Level/Impedance:	
LINE OUT:	150mV/3.3k ohms
REC OUT:	150mV
Power Requirement:	120V 60Hz
Power Consumption:	6W
Dimensions (W x H x D):	16-9/16 x 2-3/8 x 8-11/16 inches 420 x 60 x 221 mm
Weight (without package):	4 lbs. 14 oz./2.2kg

EX-9000

Dynamic Range (max.)			
	Low(50Hz)	Mid(500Hz)	High(5kHz)
Expansion Level:	17dB	12dB	17dB
Upward Gain:	+15dB	+7dB	+12dB
Downward Gain:	-2dB	-5dB	-5dB
Impulse Response			
Attack Time:	4.7msec.		
Release Time:	68msec.		
Hard Position:	2.7 sec.		
Soft Position:	2.7 sec.		
Output Voltage (Distortion 0.8%, 50k ohms, expansion level max.)			
Low (50Hz):	7.0V		
Mid (500Hz):	7.5V		
High (5kHz):	5.5V		
Input Impedance			
LINE IN, TAPE PLAY:	50k ohms		
Output Impedance (1kHz)			
LINE OUT:	1k ohms		
Signal-to-Noise Ratio:	96dB (output 1V)		
(IHF, A-network, 1kHz, all expansion level max.)			
Gain:	0dB (all controls minimum)		
Power Requirement:	120V 60Hz		
Power Consumption:	28 watts		
Dimensions (W x H x D):	16-9/16 x 2-3/8 x 8-5/16 inches 420 x 60 x 212 mm		
Weight (without package):	7 lbs. 1 oz./3.2kg		

SR-60

Reverberation Time (DEPTH volume control Min.)	
Reverb:	0—3 sec. (400Hz)
Echo:	0—3 sec. (400Hz)
Duet:	100msec. (400Hz)
Maximum Output Voltage:	6.5V (1kHz, T.H.D. 0.01%)
Total Harmonic Distortion:	0.005% (1kHz, REVERB LEVEL Min., output 1V)
Inputs (Sensitivity/Impedance)	
Reverb:	150mV/50k ohms
Tape Play:	150mV/50k ohms
Outputs (Sensitivity/Impedance)	
Reverb:	150mV/220 ohms
Tape Rec:	150mV/220 ohms
Frequency Response:	10—70,000Hz 0dB, -1dB
Signal-to-Noise Ratio:	104dB (output 2V), 98dB (output 1V)
(IHF, A-network)	
Power Requirement:	120V 60Hz
Power Consumption:	30 watts
Dimensions (W x H x D):	16-9/16 x 3-7/8 x 13-3/8 inches 420 x 99 x 340 mm
Weight (without package):	10 lbs. 2 oz./4.6kg

VSP-555

Surround Amplifier Section
Continuous average power output of 30 watts* per channel, min., at 8 ohms from 30Hz to 7kHz with no more than 5% total harmonic distortion

Frequency Response:	30—7,000Hz 0dB, -3dB
Audio Section	
Inputs (Sensitivity/Impedance)	
AL/DIC, VDP, VCR1/2, TAPE:	150mV/50k ohms
Outputs (Level/Impedance)	
VCR1/2, TAPE:	150mV/4.7k ohms
PREOUT (FRONT):	1V/4.7k ohms
PREOUT (L+R):	1V/4.7k ohms
Frequency Response:	10—70,000Hz +0dB, -3dB
(PREOUT, FRONT, L+R)	
Signal-to-Noise Ratio:	90dB
(IHF, short-circuited A-network)	
Video Section	
Inputs (Sensitivity/Impedance)	
VDP, VCR1/2,	
VIDEO ADAPTOR:	1Vp-p/75 ohms
Outputs (Level/Impedance)	
VCR1/2, VIDEO ADAPTOR,	
MONITOR:	1Vp-p/75 ohms
Frequency Response:	5Hz—6MHz +0dB, -3dB
Signal-to-Noise Ratio:	55dB
Miscellaneous	
Power Requirements:	120V 60Hz
Power Consumption:	80 watts
Dimensions (W x H x D):	420 x 120 x 336 mm 16-9/19 x 4-3/4 x 13-1/4 inches
Weight (without package):	12 lbs. 6 oz./5.6kg

CASSETTE TAPE DECKS

	CT-W900R	CT-W700R	CT-W500	CT-W300
Type:	4-track, 2-channel double auto-reverse stereo cassette tape deck (recording/playback x 2)	4-track, 2-channel double auto-reverse stereo cassette tape deck (recording/playback and playback)	4-track, 2-channel double stereo cassette tape deck (recording/playback and playback)	4-track, 2-channel double stereo cassette tape deck (recording/playback and playback)
Motors:	DC-servo motor for capstan drive x 2, DC motor for reel drive x 2	DC-servo motor x 2	DC-servo motor x 2	DC-servo motor x 2
Heads:	"Hard Permalloy" recording/playback head x 2, Ferrite erasing head x 2	"Hard Permalloy" recording/playback head x 1, "Hard Permalloy" playback head x 1, Ferrite erasing head x 1	"Hard Permalloy" recording/playback head x 1, "Hard Permalloy" playback head x 1, Ferrite erasing head x 1	"Hard Permalloy" recording/playback head x 1, "Hard Permalloy" playback head x 1, Ferrite erasing head x 1
Fast Winding Time (C-60 tape):	100 seconds	100 seconds	100 seconds	100 seconds
Wow and Flutter (WRMS):	0.055%	0.055%	0.06%	0.13%
Frequency Response (-20dB)				
Metal Tape:	18—18,500Hz	25—18,000Hz	25—16,000Hz	35—16,000Hz
Chrome Tape:	18—18,000Hz	25—7,000Hz	25—16,000Hz	35—16,000Hz
Normal Tape:	18—17,000Hz	25—6,000Hz	25—15,000Hz	35—15,000Hz
Signal-to-Noise Ratio (NR off*):	58dB	57dB	56dB	56dB
Harmonic Distortion (0dB):	0.7%	0.7%	0.7%	0.8%
Inputs (Sensitivity/Impedance)				
LINE (pin jack x 2):	63mV/56k ohms	63mV/68k ohms	63mV/68k ohms	63mV/52k ohms
Output (Reference level/Load impedance)				
LINE (pin jack x 2):	316mV/5.6k ohms	316mV/5.4k ohms	316mV/5.2k ohms	316mV/7.7k ohms
HEADPHONES (5mmØ stereo jack x 1):	81mV/8 ohms	45mV/8 ohms	45mV/8 ohms	45mV/8 ohms
Power Requirement:	120V 60Hz	120V 60Hz	120V 60Hz	120V 60Hz
Power Consumption:	26W	22W	15W	16W
Dimensions (W x H x D):	16-9/16 x 5-3/16 x 12-1/2 inches (without package)	16-9/16 x 4-9/16 x 12-7/16 inches (without package)	16-9/16 x 4-9/16 x 12-7/16 inches (without package)	16-9/16 x 4-3/4 x 10-3/8 inches (without package)
Weight (without package):	13 lbs. 4 oz./6.0kg	11 lbs. 11 oz./5.3kg	11 lbs./5.0kg	8 lbs. 10 oz./3.9kg

*S/N is improved by 10dB with Dolby B on and by 19dB with Dolby C on, both at 5kHz.

SPEAKER SYSTEMS

	DSS-9	DSS-7	DSS-5	CS-707	CS-607
Enclosure:	Bass-reflex type	Bass-reflex type	Bass-reflex type	Bass-reflex type	Bass-reflex type
Unit Layout:	Symmetrical	Symmetrical	Symmetrical		
Speakers					
Woofer:	12-inch (30cm) PG™ cone type	12-inch (30cm) PG™ cone type	10-inch (25cm) cone type	15-3/4-inch (40cm) cone type	12-inch (30cm) cone type
Midrange:	4-3/4-inch (12cm) beryllium cone type	2-1/2-inch (6.6cm) beryllium cone type	2-1/2-inch (6.6cm) cone type	4-3/4-inch (12cm) cone type	4-3/4-inch (12cm) cone type
Tweeter:	Beryllium ribbon type	Beryllium ribbon type	3/4-inch (2cm) cone type	Horn type with acoustic lens	Horn type with acoustic lens
Supertweeter:	—	—	—	Twin piezo supertweeters	Twin piezo supertweeters
Impedance:	8 ohms	8 ohms	8 ohms	8 ohms	8 ohms
Frequency Range:	30—50,000Hz	30—50,000Hz	38—20,000Hz	30—25,000Hz	33—25,000Hz
Sensitivity (1m):	91dB/W	91dB/W	91dB/W	98dB/W	96dB/W
Maximum Music Power:	240W	21CW	120W		
Maximum Power:				300W	21CW
Rated Power:	80W	70W	40W	70W	50W
Crossover Frequencies:	650Hz (Low/Mid) 4,000Hz (Mid/High)	850Hz (Low/Mid) 4,500Hz (Mid/High)	1,200Hz (Low/Mid) 5,000Hz (Mid/High)	1,500Hz (Low/Mid) 4,000Hz (Mid/High) 11,000Hz (High/Superhigh)	2,000Hz (Low/Mid) 5,000Hz (Mid/High) 11,000Hz (High/Superhigh)
Dimensions (W x H x D):	15-3/8 x 28-3/4 x 13-7/8 inches (without package)	14-9/16 x 25-9/16 x 13-9/16 inches (without package)	12-13/16 x 22-7/16 x 11-7/16 inches (without package)	17-11/16 x 28-9/16 x 10-9/16 inches (without package)	16-1/8 x 25-7/16 x 11-1/4 inches (without package)
Weight (without package):	57 lbs. 5 oz./26kg	49 lbs. 10 oz./22.5kg	31 lbs. 15 oz./14.5kg	44 lbs. 1 oz./20kg	35 lbs. 4 oz./16kg

Speaker Power Handling Capability vs. Amplifier Output Power

Normally, speakers will not be damaged even if the output power of an amplifier exceeds the speakers' allowable input power, on the condition that the amplifier is kept below its clipping level* (Use care when increasing the volume level if the amplifier has an extremely high power rating.)

There is, however, a chance that the tweeter may be damaged when the amplifier is pushed beyond its clipping level even if the amplifier's power rating is below the speakers' allowable input power.

It is therefore important to consider the allowable input power of your speakers (maximum music power) when selecting an amplifier, and at the same time, the amplifier must be operated so that its clipping level is not exceeded.

*Clipping level: The power level at which severe distortion suddenly appears due to attempts to drive an amplifier beyond its capacity.

HEADPHONES

	SE-M90	SE-M70	SE-M50	SE-50D	SE-30D	SE-20S
Impedance:	32 ohms	32 ohms	32 ohms	32 ohms	40 ohms	10 ohms
Maximum Input Power (each channel):	1,000mW	1,000mW	1,000mW	1,000mW	100mW	500mW
Frequency Range:	3—50,000Hz	3—50,000Hz	3—50,000Hz	3—50,000Hz	10—25,000Hz	20—20,000Hz
Connection Cord:	16' 5" (5m)	16' 5" (5m)	16' 5" (5m)	8' 2" (2.5m)	8' 2" (2.5m)	8' 2" (2.5m)
Weight (without connection cord):	9 oz. (255g)	9 oz. (255g)	8.1 oz. (230g)	3.2 oz. (90g)	2.5 oz. (70g)	1.0 oz. (450g)

CT-S800	CT-S600	CT-1080R
4-track, 2-channel recording and playback stereo cassette tape deck	4-track, 2-channel recording and playback stereo cassette tape deck	4-track, 2-channel auto-reverse recording and playback stereo cassette tape deck
DC-servo motor for capstan drive x 1, DC motor for reel drive x 1, DC auxiliary motor x 1	DC-servo motor for capstan drive x 1, DC motor for reel drive x 1	DC-servo motor for capstan drive x 1, DC motor for reel drive x 1
"Laser Amorphous" playback head x 1, "Hard Permalloy" recording head x 1 (combination type), Ferrite erasing head x 1	"Hard Permalloy" recording/playback head x 1, Ferrite erasing head x 1	"Hard Permalloy" recording/playback head x 1, Ferrite erasing head x 1
80 seconds	90 seconds	90 seconds
0.024%	0.055%	0.07%
20—22,000Hz 20—21,000Hz 20—21,000Hz	25—18,000Hz 25—17,000Hz 25—16,000Hz	30—17,000Hz 30—16,500Hz 30—16,000Hz
60dB	58dB	58dB
0.8%	0.7%	0.7%
67mV/50k ohms	63mV/56k ohms	63mV/51k ohms
316mV/1.4k ohms	316mV/5k ohms	316mV/5k ohms
80mV/8 ohms	81mV/8 ohms	45mV/8 ohms
120V 60Hz	120V 60Hz	120V 60Hz
25W	17W	20W
16-9/16 x 5-1/4 x 14-5/8 inches 420 x 133.5 x 372 mm	16-9/16 x 5-1/8 x 12-11/16 inches 420 x 130 x 322 mm	16-9/16 x 4 x 8-5/16 inches 420 x 101 x 211 mm
21 lbs. 3 oz./9.6kg	11 lbs./5kg	7 lbs. 8 oz./3.4kg

NOTE:

- (1) Reference tape: Normal and LH tapes are DIN 45513 (Fe). Chrome tape is DIN 45513 (Cr).
- (2) Reference recording level is meter 0dB level. (160 nwb/m magnetic level=Philips cassette reference level)
- (3) Reference signal is 315Hz.
- (4) Wow and Flutter: at 3kHz, WRMS (JIS), at 3.150Hz weighted PEAK (DIN 45507).
- (5) Frequency Responses are measured at -20dB and at 0dB levels respectively for reference recording level, Dolby off. Level deviation is ±6dB (where not indicated). (DIN 45500)
- (6) Signal-to-Noise Ratio: Measured at the third harmonic distortion 3% level, weighted (DIN 45513/BLATT7).
- (7) Sensitivity: Input level (mV) for reference recording level measured with input (recording) level control set at maximum position.
- (8) Maximum allowable input level (mV) is measured at the point where the output signal wave is clipped while gradually turning the input level control.
- (9) Reference output level is LEDs display's 0dB level.
- (10) Maximum output (Playback) level: Output level to reference recording level, measured with an output (Playback) level control set at maximum position.

*Specifications quoted for "metal" tapes are approximate. See manufacturers' data for individual tapes.

CS-407	CS-G301WAT	CS-G201WAT	CS-G101WAT	S-X7
Bass-reflex type	Bass-reflex type	Bass-reflex type	Infinite baffle type	Bass-reflex box type
12-inch (30cm) cone type 4-inch (10cm) cone type 2-1/2-inch (6.6cm) cone type with acoustic lens	12-inch (30cm) cone type 4-3/4-inch (12cm) cone type 2-1/2-inch (6.6cm) cone type	10-inch (25cm) cone type 3-inch (7.7cm) cone type 2-1/2-inch (6.6cm) cone type	10-inch (25cm) cone type 2-1/2-inch (6.6cm) cone type	3-1/2-inch (9.7cm) full-range cone type — —
8 ohms	6 ohms	6 ohms	6 ohms	16 ohms
35—20,000Hz	35—20,000Hz	40—20,000Hz	55—20,000Hz	100—20,000Hz
94dB/W	91dB/W	90dB/W	90dB/W	90dB/W
150W	120W	100W	50W	30W
40W	40W	35W	17W	—
3,000Hz (Low/Mid) 10,000Hz (Mid/High)	3,500Hz (Low/Mid) 7,000Hz (Mid/High)	3,000Hz (Low/Mid) 6,000Hz (Mid/High)	5,000Hz (Low/High)	—
14-15/16 x 24-13/16 x 10-3/8 inches 380 x 630 x 263 mm	14-15/16 x 26-1/2 x 13 inches 380 x 673 x 330 mm	13-3/4 x 24 x 11-13/16 inches 350 x 610 x 300 mm	13 x 22-7/16 x 7-13/16 inches 330 x 570 x 198 mm	5-3/8 x 7-1/2 x 4-1/2 inches 136 x 190 x 115 mm
23 lbs. 2 oz./10.5kg	29 lbs. 12 oz./13.5kg	20 lbs. 15 oz./9.5kg	14 lbs. 5 oz./6.5kg	3 lbs. 5 oz./1.5kg

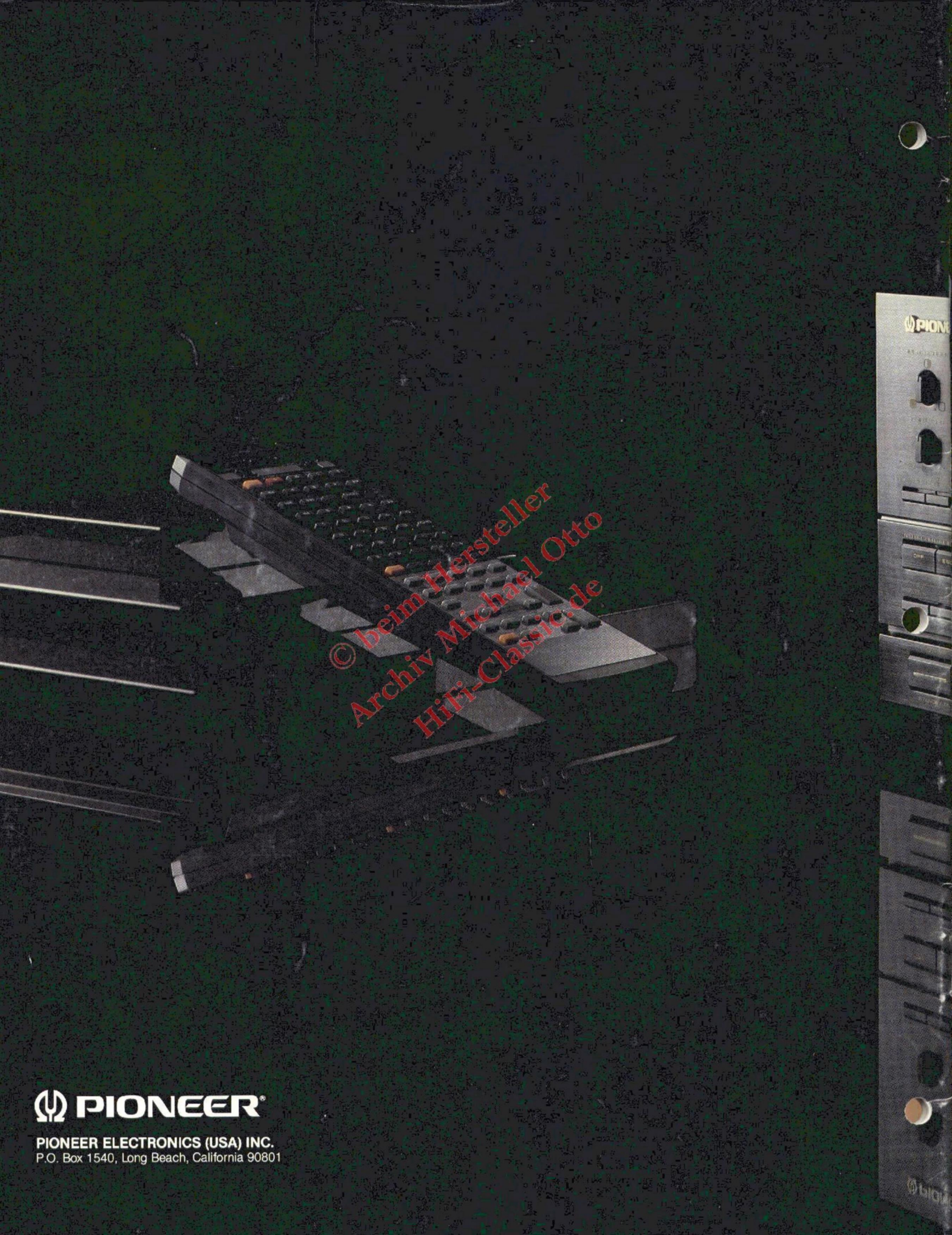

© beim Hersteller
Archiv Michael Otto
HiFi-Classic.de

 **PIONEER®**

PIONEER ELECTRONICS (USA) INC.
P.O. Box 1540, Long Beach, California 90801

