

# HI-FI

COMPONENTS

© beim Hersteller  
Archiv Michael Otto  
HiFi-Classic.de





© Hifi-Hersteller  
Archiv Michael Otto  
HiFi-Classic.de

## Pioneer welcomes you to the digital audio age

This is a dynamic time in the exciting world of audio. Highly touted digital recording and playback techniques have finally arrived, and they deliver exactly what they promised — perfectly flat frequency response, almost no noise or distortion and super-wide dynamic range.

Pioneer is a pacesetter in digital technology thanks to certain advantages we enjoy, such as our

pioneering research in lasers for our LaserDisc™ video players. You'll find that every piece of equipment in this catalog was designed for the digital audio age: from our digital audio Compact Disc player to our audio/video receivers. From our PG™ cone speaker systems to our microcomputer controlled decks and turntables. Welcome to the digital audio age. Welcome to Pioneer.

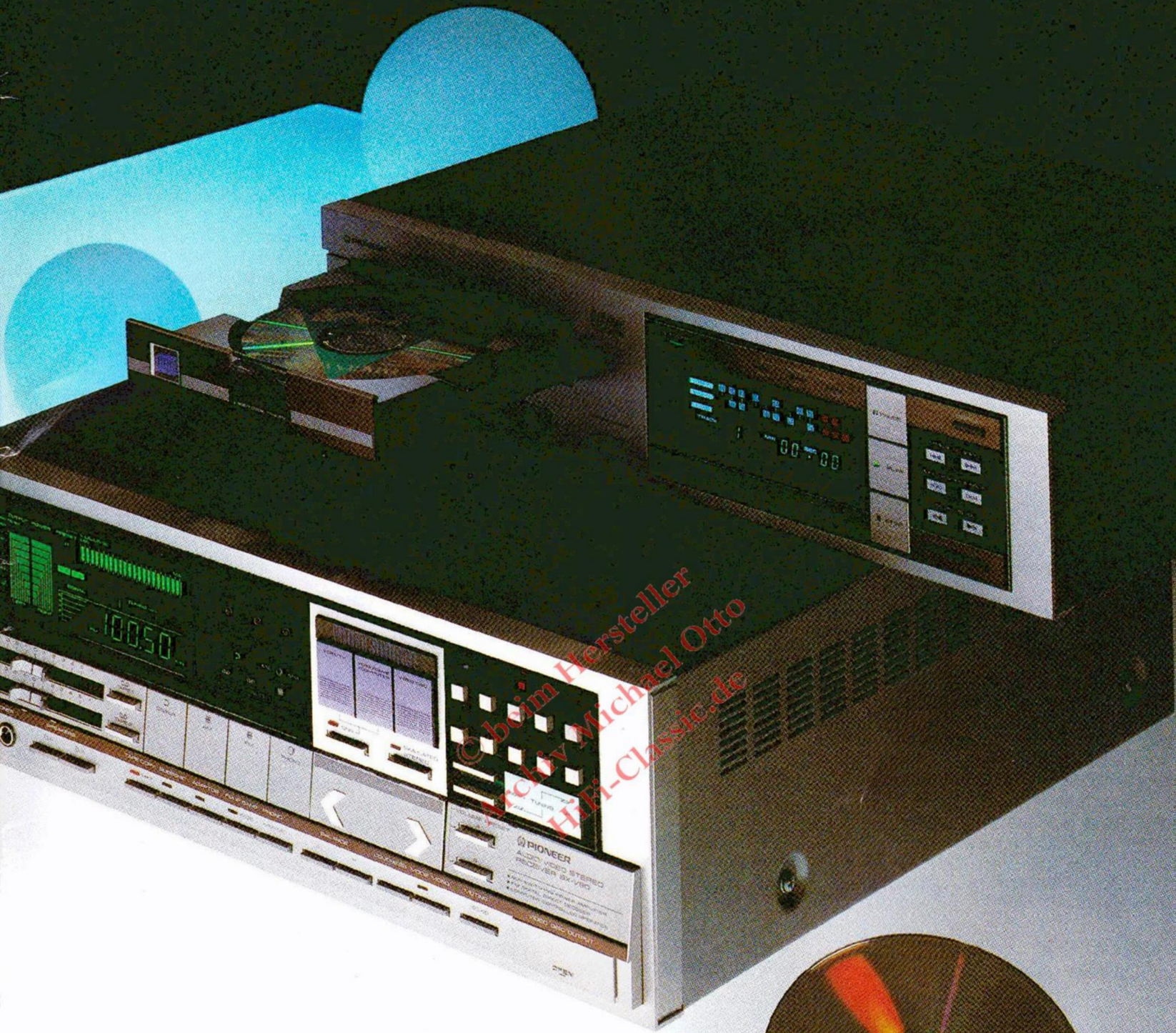

© beim Hersteller  
by Michael Otto  
Hi-Fi-Classic.de



# Pioneer Compact Disc Player

## The Technology

### A look at analog

Sound, including the music reproduced by audio speakers, is analog. That is, the signal varies continuously. Conventional recording and playback systems are also analog in that the information they record, store and play back is "analogous" to the original sound. However, this information, whether it be an electrical signal, physical undulations in a record groove or magnetic variations on a recording tape, is susceptible to damage. The introduction of unwanted noise and distortion can affect the electrical signal. A record groove can suffer physical damage. A magnetic tape can become unmagnetized (high frequencies are particularly susceptible). The purpose of top-quality audio equipment is to *minimize* the deterioration of the analog information.

### Digital recording

Rather than minimizing deterioration of information (sound), digital recording techniques prevent it. This is done by sampling the signal at a very high rate and assigning digits (the binary numbers 1 and 0) to the measured values. For example, the Compact Disc Digital Audio System has a sampling rate of 44.1kHz; in other words, one second of music is measured 44,100 times. These measurements are turned into a series of discrete stepped voltages which are then converted into digital "bits" by an ADC (Analog-to-Digital Converter). This process is known as "quantization."

### Digital storage

The digital bits are stored on a plastic

Compact Disc in the form of microscopic pits arranged in tracks only  $1.6\mu\text{m}$  apart. Since the pits are read optically by a laser beam, they can be sealed safely under a layer of transparent plastic. Stored in this way, music signals in digital form are not subject to external noise and distortion.

### Digital pickup

Retrieving digital information is extremely simple in principle. A digital reader need only differentiate between 1 (presence of a pit) and 0 (absence thereof), leaving very little room for error. To ensure that the correct signals are read at the correct time, the CD player employs three servo systems to monitor tracking. To compensate for dropouts, the player uses a powerful error correction system (interleaving). A missing signal is interpolated from signals preceding and following it, thus the absence of a signal is not apparent at the output.

Next, the digital signal is converted back into an analog signal by a DAC (Digital-to-Analog Converter). Finally, the signal goes through a low-pass filter to eliminate extraneous ultra high frequencies, and appears as an audio signal at the output, just like the signal from a tuner or tape deck.

### Compact Disc: Physical characteristics

• *No loss of musical information.* Digital transfer processes are error free. Thus digital information can be transferred from one source to another with absolutely no loss of signal quality. The sound you hear

from a Compact Disc is as clean and clear as the digital master.

• *No disc wear.* Since the billions of microscopic pits on a Compact Disc are sealed beneath a transparent layer of plastic, they are fully protected against damage. And since the laser pickup focuses beneath the surface layer, dust and small scratches on the surface are ignored. Unlike phonograph records, no annoying pops, crackles or ticks occur.

• *One hour of music from a single disc.* Only 4-3/4 inches (12cm) in diameter — small enough to put into your coat pocket — a single-sided Compact Disc can hold over one hour of music.

• *Convenient search and random access functions.* Every Compact Disc has search and random access information encoded on it that is read by the player before play. This is what makes possible extraordinarily convenient functions such as search, random access and time displays.

### Compact Disc: Specifications

Noise and distortion are essentially nonexistent. Dynamic range is the equal of a live performance — fully 50% better than conventional analog systems. Response is ruler flat at all audible frequencies. Channel separation is practically infinite. To be more specific:

- Dynamic range better than 95dB.
- Signal-to-noise ratio better than 95dB.
- Harmonic distortion less than 0.004%.
- Channel separation greater than 90dB.
- Frequency response flat within  $\pm 0.5\text{dB}$  from 5Hz to 20kHz.
- Wow and flutter unmeasurable.

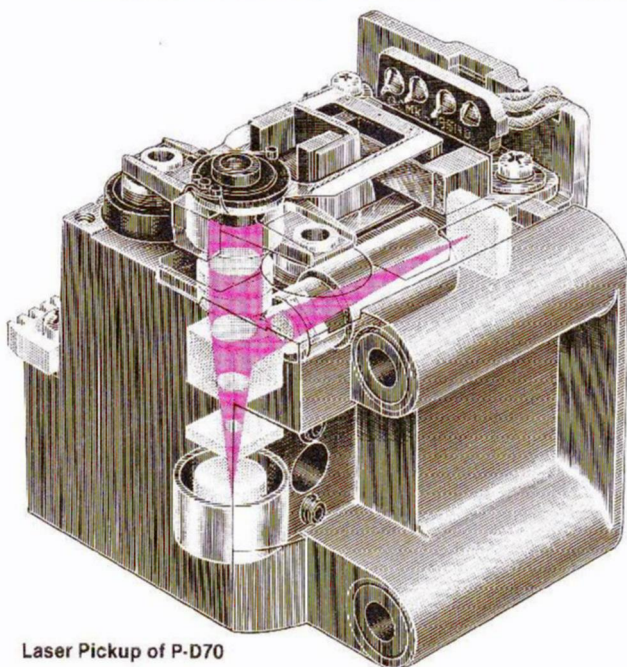

Laser Pickup of P-D70

### Audio Output Waveforms After Error Correction and Interpolation

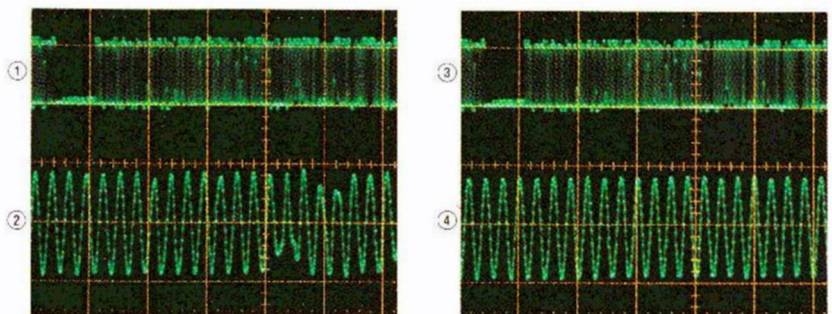

#### Our Test Model

① 2msec/div.  
EFM signal with burst error of 10 consecutive frames.  
Signal of about 1.36msec duration is missing.  
② 500 $\mu\text{s}$ /div.  
7kHz FS sine-wave output. Error correction is impossible.  
Though an average signal value is arrived at to compensate for the error, the waveform is distorted.

#### P-D70

③ Same as ① left.  
④ 500 $\mu\text{s}$ /div.  
7kHz FS sine-wave output. Error is corrected accurately, therefore the output waveform shows almost no distortion.



## P-D70 COMPACT DISC PLAYER

### Audio technology takes a giant leap forward

Pioneer is no newcomer to laser and digital electronic technology — many of the techniques first developed for our LaserDisc™ video systems are used in our new P-D70 Compact Disc player. Its high-performance optical laser featuring a 3-spot beam system was developed by our research laboratory to solve the problem of tracking error. It utilizes three servo systems: a focus servo to keep the laser's focus on the reflective surface of the disc, a tracking servo that monitors adjacent tracks to ensure that the laser beam is always in the exact center of the track, and a spindle servo to continuously adjust the rotational velocity of the disc so that linear velocity remains constant.

The analog filter we developed for the P-D70 is a special 11th order low-pass filter. The signal processing circuitry in LSI (Large-Scale Integrated Circuit) form contributes to better sound by improving error detection and correction capability. It can even compensate for dropouts of up to 12 consecutive burst frame errors. This means

any discs on the market can be played trouble-free on the P-D70.

An unusual feature of the P-D70 is its meter system. In the BINARY display mode it lets you watch actual bits of data as they are read from the Compact Disc and processed for an analog (audio) output. It further shows the peak levels over a wide range of 72dB from -54dB to +18dB. In the PEAK display mode it shows peak levels. Since the meters operate from digital data, response is accurate over the entire range from -36dB to +12dB.

The versatile 4-way display system of the P-D70 shows you the total play time of the disc in minutes and seconds. Each time you press the DISPLAY button, the display shows the index number, total play time (with total number of tracks), and remaining play time. Also shown is the track in play at any moment.

Operating the P-D70 is extremely easy thanks to its front-loading configuration and a wealth of convenient, easy-to-use features.

These include Track Search so you can quickly skip ahead or behind one or two tracks. Minute Search that lets you skip exactly one, two, three, etc. minutes of play time ahead or back. Index Search so you can start play from any indexed point within a track. Programmed Memory Play so you can play tracks (up to 10) in any order you wish. And others like Slow Scan and Repeat Play for even more convenience. The P-D70: Pioneer digital sound at its finest.

# Pioneer Receivers

## The Technology

Every Pioneer receiver offers unusually high power for its price. And making each an even better value are the many features we've incorporated for easier operation and unexcelled sound quality. The tuner sections offer the accuracy Pioneer is renowned for, and have a full selection of conveniences. Look around: you'll be convinced that Pioneer receivers are in a class by themselves.

### Non-Switching\* Amp eliminates switching distortion

Three of our receivers — SX-V90, SX-60 and SX-50 — feature a revolutionary Non-Switching power amplifier design. It uses a high speed servo called a "Vari-Bias\*" that automatically adjusts the bias current to the power transistors in accordance with the input level. During operation, the power transistors are never allowed to switch off; this means switching distortion is avoided and music will be reproduced faithfully with a new sense of clearness. Pioneer Non-Switching amps provide the smooth, low-distortion sound of expensive class-A amps, and the high efficiency of class-B amps. You get best-of-both-worlds performance. This is just one more example of Pioneer's technological edge.

(\*Non-Switching and Vari-Bias are trademarks of Pioneer.)

### Digital Direct Decoder

The SX-V90 features the very best of our industry-leading tuner technology — a Digital Direct Decoder for FM in IC form. In a nutshell, it provides low distortion, a high signal-to-noise ratio and wide separation — hi-fi specifications all the way. For more details, refer to the tuner technology section.

### Quartz-PLL digital synthesizer tuning: Accuracy and preset station convenience

Four top Pioneer receivers feature Quartz-PLL digital synthesizer tuning. It guarantees that stations, once tuned, will never again drift out of tune, whatever the cause — temperature, humidity, or else.

Our Quartz-PLL tuning system offers easy operation too: you can preset a large number of your favorite FM and AM stations — 10 for each tuning band in the SX-V90 and SX-60, 8 in the SX-50 and SX-40. Once stations are preset, you can recall them instantly at the touch of a button. Another tuning mode, Auto tuning, lets you quickly tune stations up and down the tuning band automatically.

### Simulated stereo for mono programs

Most musical software, such as records, tapes and FM, is available in stereo. But there are still some programs available only in mono — TV broadcasts, most video tapes, video discs and AM radio. This is why we've included a simulated stereo circuit in all but our two least expensive models. Connect the audio output of your video equipment to the VIDEO terminals on our receivers, and enjoy stereo sound through your hi-fi system. Of course you can get the same simulated stereo effect from AM radio, mono records and tapes.

### Simplified operation

Our top four receivers have had operation simplified by means of a host of indicators and microcomputer control. Selected inputs, tuned preset stations, power output and other vital information are clearly shown on an oversized fluorescent panel (SX-V90, SX-60 and SX-50). Switches are all electronic for easier and surer operation.

### The presettable receiver

Of all our receivers, the versatile SX-V90 is actually our easiest to use. The reason is it incorporates a sophisticated computer control system that permits many functions to be preset.

**Preset FM IF bandwidths:** When you preset an FM station, you can also preset its IF bandwidth. So each time you tune the preset station, its IF bandwidth is automatically set as you've selected — wide for top hi-fi sound or narrow for interference-free reception.

**Preset volume:** You can keep two favorite volume settings in the computer memory for instant one-touch recall. Also you can preset the on/off position of the loudness and muting controls for each preset volume setting.

**Preset sensitivity:** The slight difference (up to  $\pm 6$ dB, re tuner level) in output level between various equipment (turntables, Compact Disc player, VCRs, etc.) can be compensated for and preset, input for input. So as you switch from one input to another, from video to audio, etc., you don't need to adjust the level control each time.

## Distortion Spectra

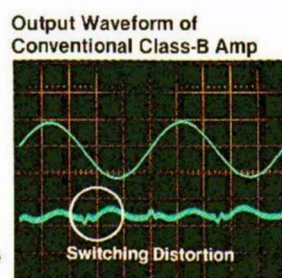
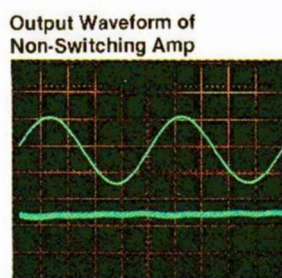
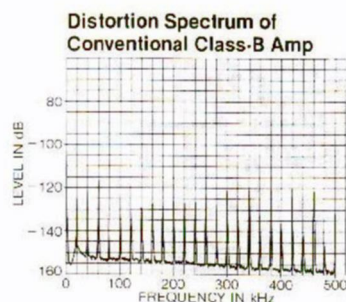
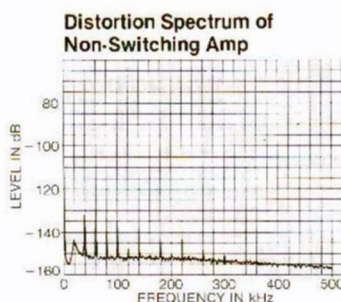

## Video ready

The SX-V90 is designed to integrate both audio and video systems: in addition to standard audio equipment it accepts and controls one video disc player, two VCRs (Videocassette Recorders), one monitor TV and one TV receiver.

It lets you do far more than just switching from one video source to another, or from video to audio and back again. For one, you can dub videotapes from one VCR

to another, while listening to any audio source (records, tapes, etc.). You have access to the output of a video disc player through front-panel terminals. You can even operate your personal computer or play a video game thanks to the versatile video switching facilities of the SX-V90.

Video sound is also improved by the SX-V90 — a DNR\* (Dynamic Noise Reduction System) is built in. The circuit analyzes the high-frequency content of the sound

from a video source (connected to VCR 1 and 2 terminals) and automatically attenuates highs when hiss and other noise are excessive. When you hear the great sound of your video tapes and TV broadcasts played through the SX-V90, you too will become a believer.

(\*DNR is a trademark of National Semiconductor Corporation.)

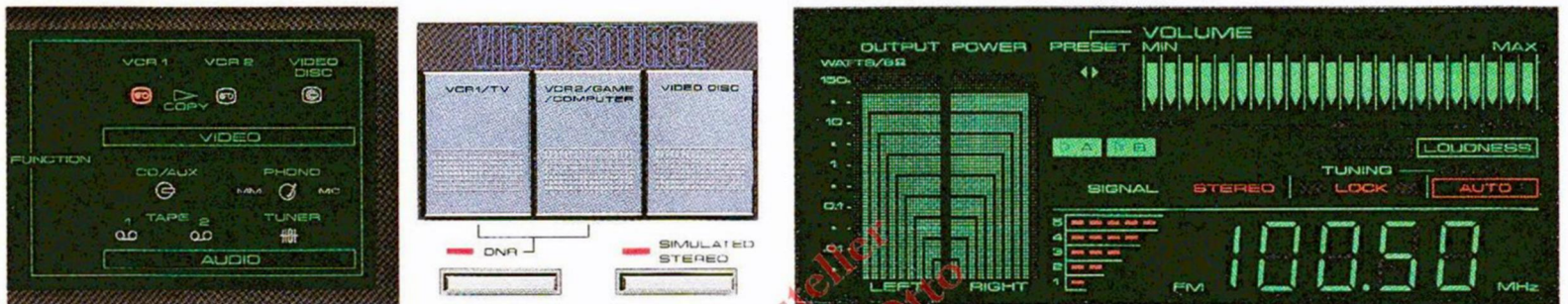

### Connection diagram for the SX-V90

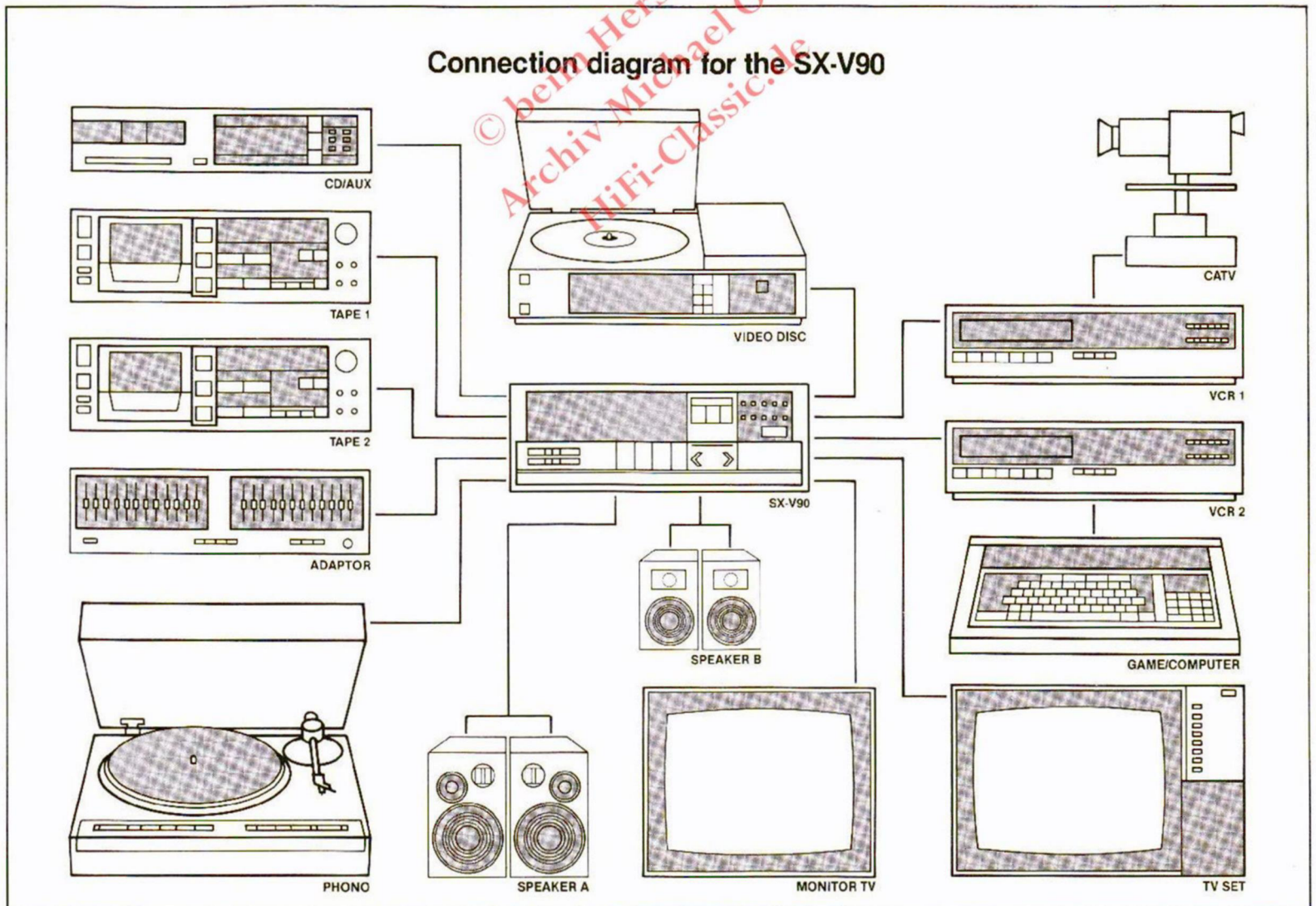

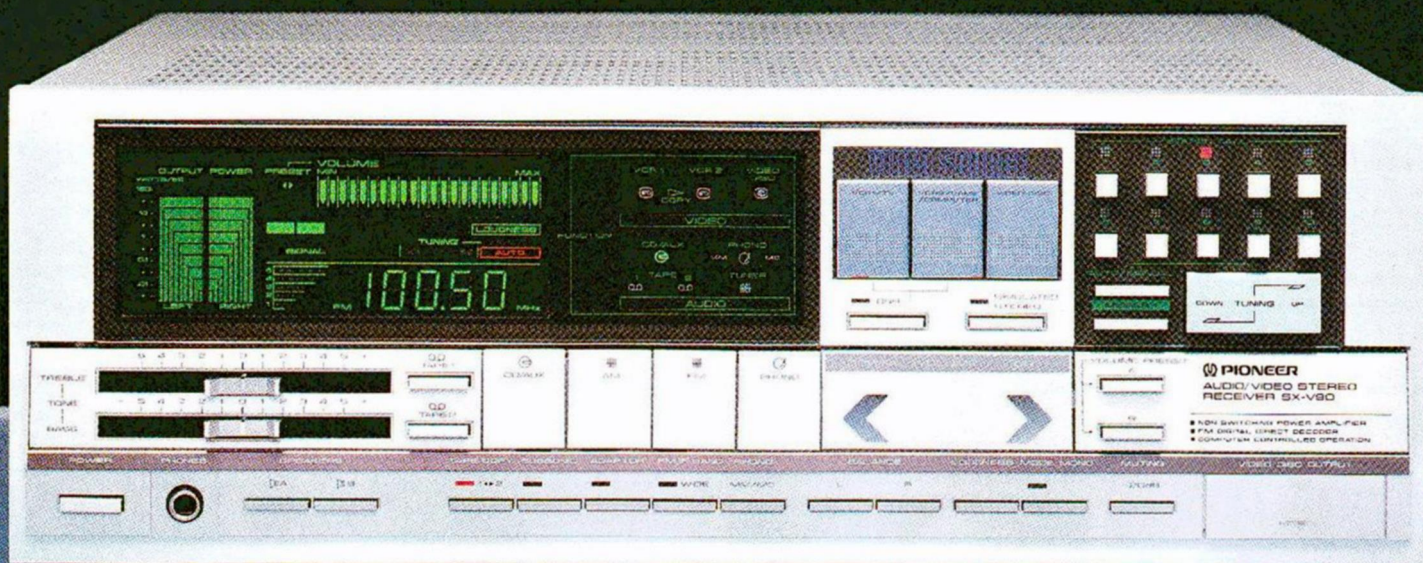

© beim Hersteller  
 Archiv Michael Otto  
 HiFi-Classic.de

NON SWITCHING AMP™

## SX-V90 NON-SWITCHING QUARTZ-PLL SYNTHESIZER RECEIVER

### The nerve center for your integrated audio-video system

Here is a truly unique receiver that is designed to help you integrate your audio and video equipment into one easy-to-operate system. In addition to audio components (a turntable, two decks, etc.), it connects and controls up to three video units (both audio and video signals) — two VCRs and one videodisc player. Alternately, you can connect a personal computer or a video game. The SX-V90 is that versatile.

Circuits for the sound of video equipment are all stereo, of course. If your video suffers from noise, there is a built-in DNR (Dynamic Noise Reduction System) that works miracles to provide you with better sound. If your source is mono, a built-in circuit creates a simulated stereo output. That's not all: you can also dub from VCR 1 to VCR 2 while listening to any audio program. At the front is available the output from a connected videodisc player.

But don't forget that the SX-V90 is a high-performance audio receiver. As such, it is as capable as any. Its power amp

boasts **a continuous average power output of 125 watts\* per channel, min. at 8 ohms, from 20 hertz to 20,000 hertz with no more than 0.005% total harmonic distortion.** For good, low-distortion sound, it features the Pioneer Non-Switching power amp.

The SX-V90's tuner features the new innovative Digital Direct Decoder (modified in IC form) to effectively reject interference. Working with two more interference rejection circuits — an exclusive selective ID MOS FET RF amp and an FET balanced mixer — it dramatically reduces noise and distortion, rendering music surprisingly clear and smooth.

Another big surprise is the preset capability made available by the 4k-byte ROM microcomputer. You can preset 10 FM stations plus an equal number of AM stations. You can preset two favorite volume levels, along with loudness and muting. You can preset the compensated-for differences in output levels of various program sources,

so that all will play at the same volume. You can even pre-select the IF bandwidth (wide or narrow) for each FM station.

Other features: a large fluorescent display panel with innovative power level indicator, bi-directional tape dubbing (audio), a subsonic filter, adaptor loop circuit, connection for MM and MC cartridges, slide tone controls, jumpers to separate pre and power amps, speaker A/B switches, and battery memory backup.

\*Measured pursuant to the Federal Trade Commission's Trade Regulation Rule on Power Output Claims for Amplifiers.

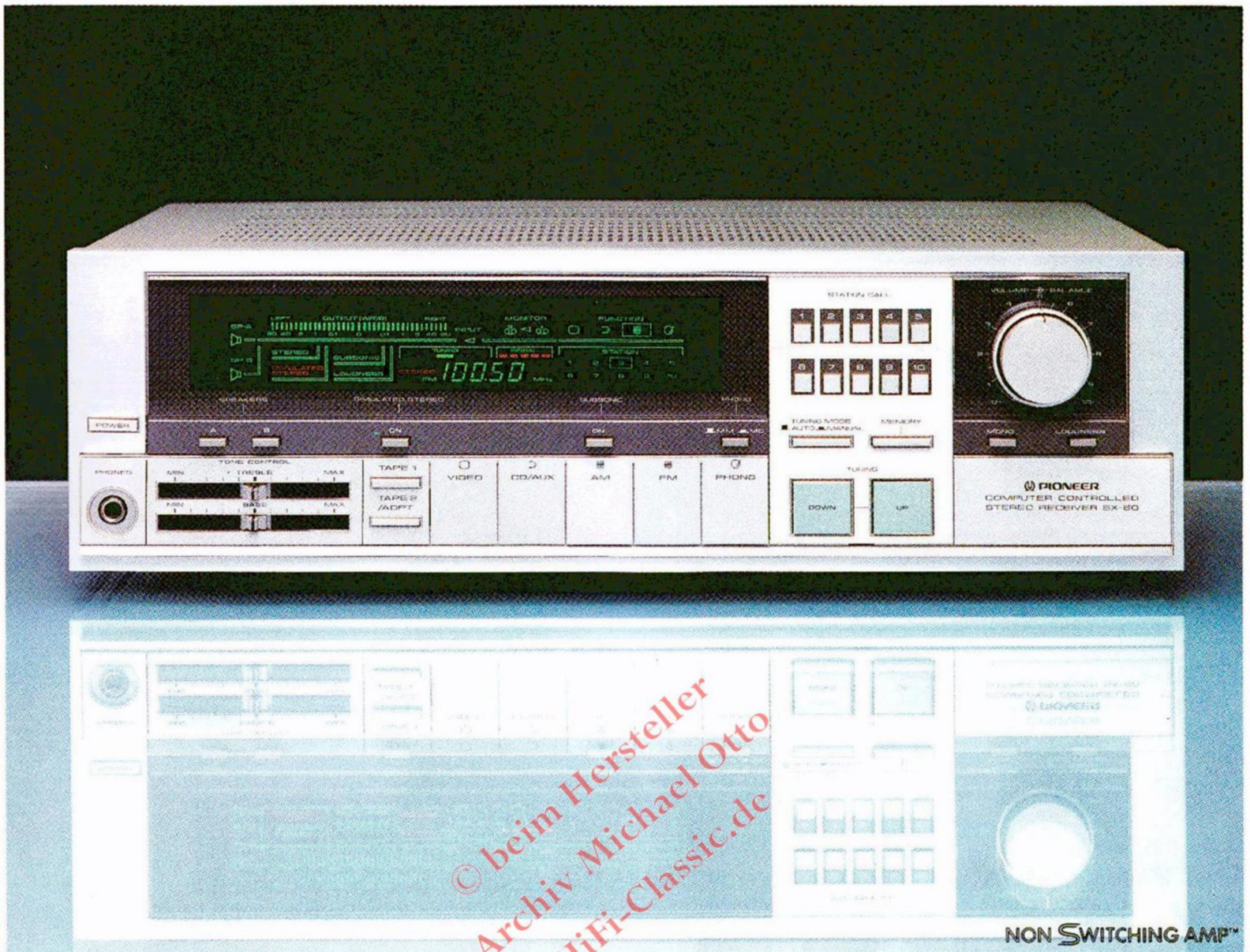

## SX-60 NON-SWITCHING QUARTZ-PLL SYNTHESIZER RECEIVER

### Designed with an emphasis on simple operation

Pioneer is the pace-setter in hi-fi engineering. So it's only natural that in the field of receiver technology we were among the first to develop sophisticated systems that actually simplify operation, such as pushbutton preset tuning, comprehensive indicator displays and computer control. The SX-60 is a fine example of what we mean.

It features unusually big power for its price — **continuous average power output of 80 watts\* per channel, min. at 8 ohms, from 20 hertz to 20,000 hertz with no more than 0.005% total harmonic distortion.** Yet power is just one feature of our finest receiver; the Non-Switching amp is another. This advanced power amp design combines the advantages of low-distortion class-A operation and high-efficiency class-B operation. Power transistors are always on thanks to our bias-tracking Vari-Bias circuit. There's no switching, therefore no switching distortion, yet efficiency is always high. This is the single most important factor in the smooth, silky

sound of the SX-60.

Its tuner section has a number of surprises for you. First, it offers quartz-PLL digital tuning for accuracy, and a total of 10 FM and 10 AM station presets for instant touch recall. Second, it has an auto tuning mode that lets you easily locate stations up and down the tuning band. And finally, it has Pioneer's selective ID MOS FET front end that effectively rejects interference to let you hear stations you normally can't. Of course, there's a digital readout to show the frequency of stations you've tuned.

The center of attention of the SX-60 is the one-panel fluorescent display. It gives you information on: selected inputs, tuned preset stations, signal flow, selected speakers, and power output. The panel also indicates STEREO and SIGNAL STRENGTH as well.

All circuits of the SX-60 are controlled by a microcomputer, the reason it is so easy to use and reliable. The computer has also allowed us to use electronic switches for

more comfortable touch operation.

A video input on the back panel lets you connect a video tape recorder or video disc player to the SX-60, and enjoy its sound through your hi-fi system. The simulated stereo switch lets you enjoy enhanced stereo from any mono program source, such as video tape, TV, FM and AM.

Other features include speaker A/B switches, a high-gain phono equalizer for moving-coil cartridges, a subsonic filter, inputs for two decks and slider tone controls.

Computer control for comfortable operation

# SX-50

NON-SWITCHING QUARTZ-PLL SYNTHESIZER RECEIVER



- **Continuous average power output of 50 watts\* per channel, min. at 8 ohms, from 20 hertz to 20,000 hertz with no more than 0.007% total harmonic distortion.**
- **Non-Switching Power Amplifier:** Eliminates switching distortion while retaining high efficiency.
- **Quartz-PLL synthesizer tuning:** Drift-free reception for hours of hi-fi listening.
- **Presets for 8 FM and 8 AM stations:** Your favorite stations are only a touch away.
- **Computer control:** Assures years of reliable operation, and makes possible the use of electronic switches for more comfortable operation.
- **Video ready:** Allows you to enjoy video and TV sound through your hi-fi system.
- **Simulated stereo:** Derives enhanced stereo from any mono program.
- **One-panel fluorescent display:** All the information you need concerning operating status is shown in one place.
- **Other features:** Speaker A/B switches, subsonic filter, tape 1 and 2, slider tone controls.

Total ease of operation and comprehensive displays

# SX-40

QUARTZ-PLL SYNTHESIZER RECEIVER



- **Continuous average power output of 38 watts\* per channel, min. at 8 ohms, from 20 hertz to 20,000 hertz with no more than 0.02% total harmonic distortion.**
- **Quartz-PLL synthesizer tuning:** Drift-free reception for hours of hi-fi listening.
- **Presets for 8 FM and 8 AM stations:** Your favorite stations are only a touch away.
- **Computer control:** Assures years of reliable operation, and makes possible the use of electronic switches for more comfortable operation.
- **Video ready:** Allows you to enjoy video and TV sound through your hi-fi system.
- **Simulated stereo:** Derives enhanced stereo from any mono program.
- **Comprehensive LED display:** All the information you need concerning operating status is shown in one place.
- **Other features:** Speaker A/B switches, subsonic filter, tape monitor, slider tone controls.

\*Measured pursuant to the Federal Trade Commission's Trade Regulation Rule on Power Output Claims for Amplifiers.

Sleek, low-profile design featuring advanced circuitry

## SX-303 FM/AM STEREO RECEIVER

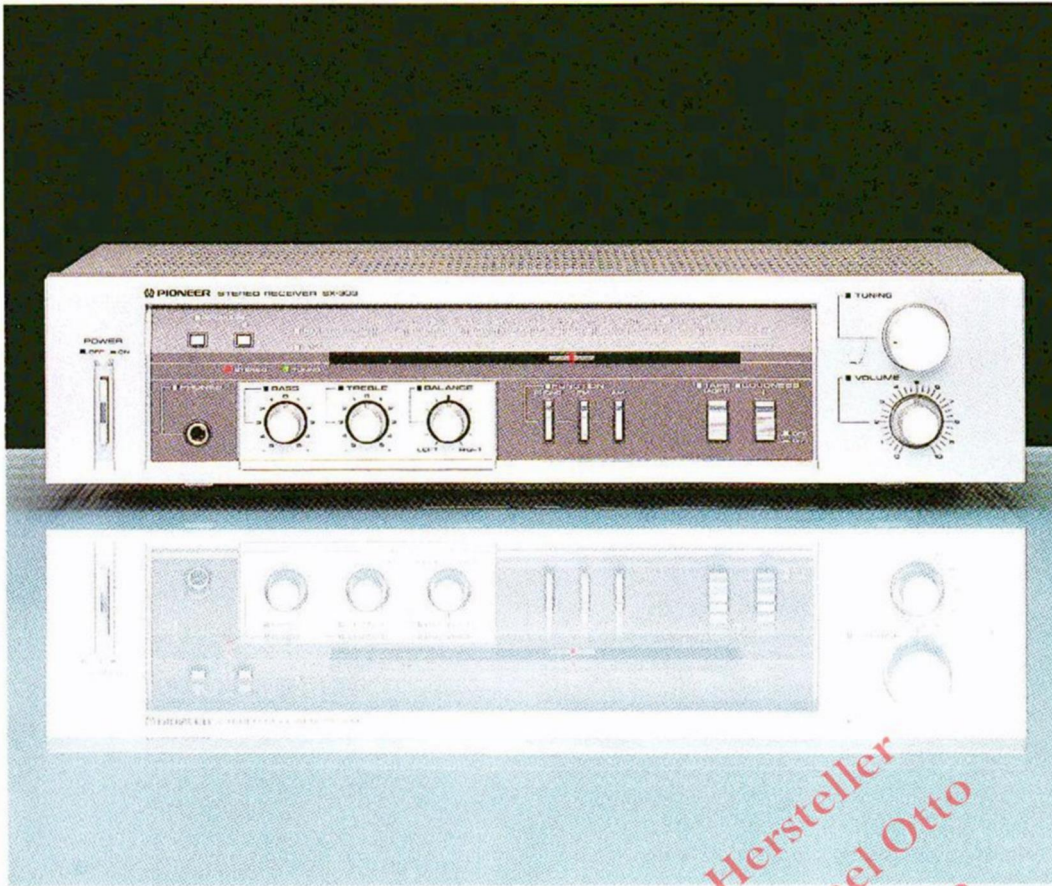

- **Continuous average power output of 45 watts\* per channel, min. at 8 ohms, from 40 hertz to 20,000 hertz with no more than 0.3% total harmonic distortion.**

- **FET FM front end:** For higher sensitivity and selectivity. You'll hear FM with lower distortion and wider range.

- **PLL stereo demodulator in IC form:** Assures wide separation, low distortion, and requires no periodic realignment.

- **Independent speaker A/B switches:** Let you drive two pairs of speakers independently.

- **Bass/treble tone controls and loudness:** Let you tailor sound to taste. Loudness gives you natural response when listening at low levels.

- **Other features:** Tape monitor, STEREO and TUNING indicators, LED tuning pointer, balance control, phones output.

Look no further; here's the receiver you've been waiting for

## SX-202 FM/AM STEREO RECEIVER

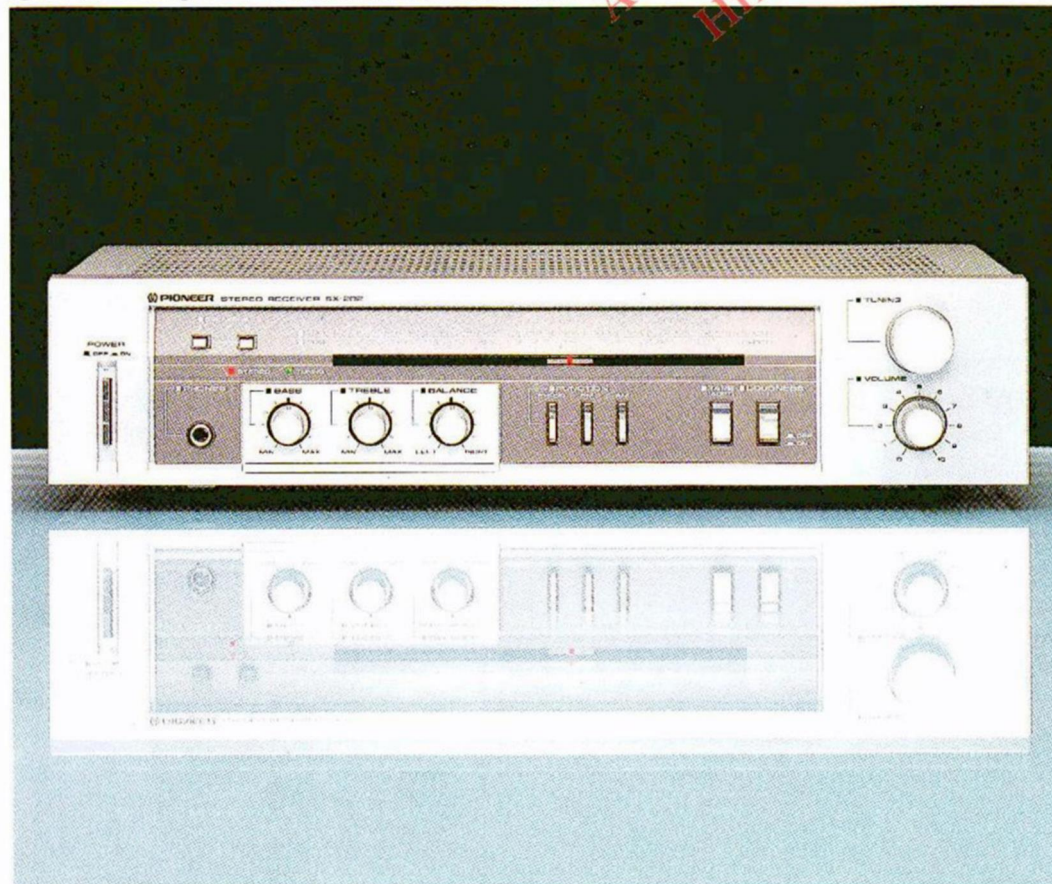

- **Continuous average power output of 25 watts\* per channel, min. at 8 ohms, from 40 hertz to 20,000 hertz with no more than 0.3% total harmonic distortion.**

- **FET FM front end:** For higher sensitivity and selectivity. You'll hear FM with lower distortion and wider range.

- **PLL stereo demodulator in IC form:** Assures wide separation, low distortion, and requires no periodic realignment.

- **Independent speaker A/B switches:** Let you drive two pairs of speakers independently.

- **Bass/treble tone controls and loudness:** Let you tailor sound to taste. Loudness gives you natural response when listening at low levels.

- **Other features:** Tape monitor, STEREO and TUNING indicators, LED tuning pointer, balance control, phones output.

# Pioneer Amplifiers

## The Technology

Pioneer's famed Non-Switching amplifier design has been improved with the addition of the new Dynamic Power Supply. The A-90, A-70 and A-60 are our Dynamic Power Non-Switching amplifiers. Each offers greatly expanded dynamic range and improved power-supply efficiency for exceedingly clean sound that is completely free of clipping.

### Compact Discs with astounding 90dB of dynamic range

For an amplifier it is not enough if it merely reproduces the signals fed to it. It must give the listener *realistic* reproduction, a recreation of the excitement and thrill of a live performance.

Now that the Compact Disc Digital System has arrived, a tremendously wide dynamic range of 90dB is available, a far cry from the mere 60dB or so (at best) of analog records and FM radio. Wider dynamic range, however, requires greater instantaneous power from an amplifier — power to spare.

Suppose the average level you normally listen at is referenced to 0dB. During musical crescendos and thunderous attacks, the amplifier must deliver 20dB more power to avoid clipping. If you want to enjoy your music — rock, jazz or classical — to the fullest without a hint of distortion during peaks, 20dB of peak level margin is a must.

Suppose, again, the average level at which you listen to music is 1 watt, which equals 0dB. The difference of 20dB between the average level and peak level represents a difference of a factor of 100. So it means you need about 100 watts of instantaneous power (per channel) during very loud passages. (Naturally, how much power you actually require depends also on your

personal listening habits, the size of your listening room and the efficiency of your speakers. What's disturbingly loud to one person may be comfortable to another.)

How do we cope with the higher power that new Compact Discs and audiophile analog records demand? Increasing the size (and capacity) of the power supply for more output power is not the answer. Rather, we need a more efficient and more responsive power supply, like Pioneer's new Dynamic Power Supply. It's the design for the digital age.

### The Dynamic Power Supply reduces power loss by a factor of two

Pioneer's Dynamic Power Supply consists of two power supply systems,  $V_L$  which feeds low voltages and  $V_H$  which feeds high voltages. During soft and moderate level passages, the  $V_L$  section provides low voltage to the output transistors. But when the level rises as the sound becomes louder, the  $V_H$  section is turned on. As you see from the oscilloscope photos on the opposite page, the high-voltage power supply is designed to track the level of an input signal with a constant voltage margin. This avoids clipping. Moreover, when a series of high-level, high-frequency inputs is applied, the  $V_H$  section remains on for some time even after the level of the signals becomes low. This ingenious design prevents instantaneous, pulse-like high-frequency signals from clipping.

The amazing Dynamic Power Supply has double the power supply efficiency of conventional class-B amps. In other words, the output transistors have only half the power loss of other designs.

### Non-Switching Amp for no switching distortion

In the A-90, A-70 and A-60, the Dynamic Power Supply is coupled with the equally revolutionary Non-Switching power amplifier design — an incomparable match for clear, low distortion sound. The Non-Switching design uses a high speed bias servo called "Vari-Bias" that controls the bias current to power transistors in accordance with variations in input level. It ensures that the transistors never switch off. Since there's no switching, there's no switching distortion. Sound is rendered clear and smooth.

### Built-in moving-coil cartridge capability

The A-90 has a separate pre-preamp for moving-coil cartridges. Its design is perhaps the most sophisticated and accurate ever conceived — push-pull circuitry from input to output, an ultra-low-noise FET input in parallel push-pull configuration, and a DC-servo. The capabilities of this pre-preamp are so impressive they are almost at the theoretical limit — a signal-to-noise ratio of 74dB (re 150 $\mu$ V input), for instance.

The phono equalizer of the A-70 and A-60 is built around a high-gain DC-servo circuit featuring a low-noise dual FET input. Again, it is of high caliber, delivering a signal-to-noise ratio of 70dB for moving-coil cartridges and an even better figure for moving-magnet cartridges.

### Dynamic Range and Frequency Response: Analog vs. Digital

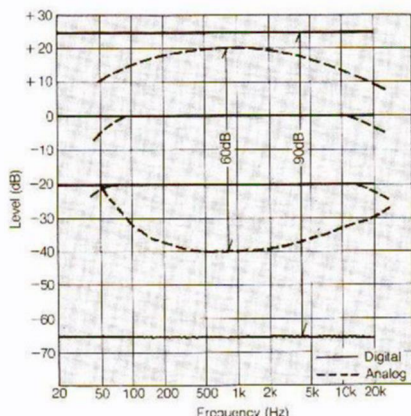

From the chart, three distinct properties of digital audio are discernible. One, the noise level of digital audio is consistently -65dB or less, a full 25dB better than analog audio. Two, the peak level margin of digital audio is 25dB, 5dB better than conventional analog audio. And three, a dynamic range of 90dB is available at *any* frequency and at *any* level. With analog audio, flat response is impossible at any level, and even marginally flat response is possible only at low levels.

### Block Diagram of Dynamic Power Supply

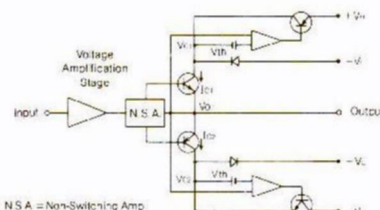

The Dynamic Power Supply consists of two complementary systems — a low-voltage system  $V_L$ , and a high-voltage system  $V_H$ . At most times, only  $V_L$  is in operation, feeding power to the output transistors; but when the level passes a certain threshold value,  $V_H$  is turned on to provide additional power to the transistors.

## Dynamic Waveforms of Actual Music

Shown below is the dynamic waveform of an actual piece of music — the opening section of Brahms's Ballade for Piano No. 3, "Intermezzo." As you see, the peak at point ② has a level about 20dB higher than the average level, point ①. Variations of the same magnitude are common even in solo piano music. Also you can see that there are

silent passages where the level drops to 0dB. From this demonstration, it is evident that an amplifier must not only have high power, but also a high signal-to-noise ratio and low distortion in order to reproduce the real-life dynamic range of music faithfully.

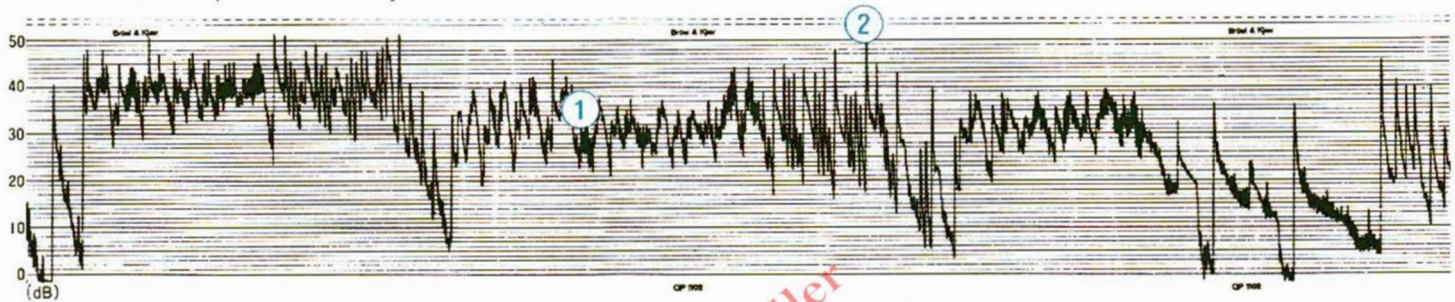

### Voltage Waveform of Dynamic Power Supply

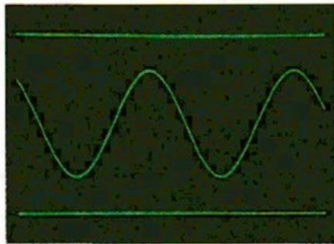

#### 400Hz output, average level

Most of the time, during low-level passages, the low-voltage power supply,  $V_L$ , is feeding electrical power to the output transistors.

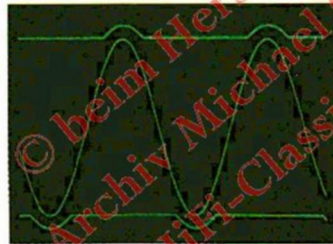

#### 400Hz, high level

But when a loud passage appears, the power supply is switched from  $V_L$  to  $V_H$ . This ensures that the power supply voltage tracks the level of the program signal at all times.

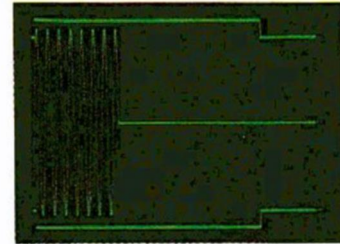

#### 5kHz, high level

Shown is the voltage waveform of the power supply during reproduction of a high-level, high-frequency signal. Even after the signal is removed, the high-voltage power supply is kept on for some time. This prevents transient high frequencies from being clipped, however suddenly they appear.

## Comparison of Distortion Waveforms

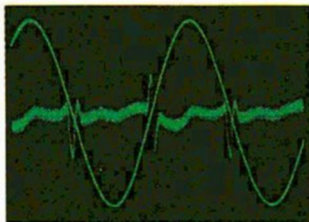

#### Conventional Class-B Amp

As transistors turn on and off, signals of a pulsive nature are generated. This is known as switching distortion.

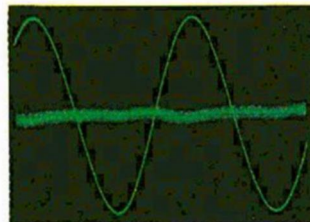

#### Non-Switching Amp

The pulsive signal you see in the left photo is not apparent here. No switching distortion is generated.

## Block Diagram of Head Amp for MC Cartridges

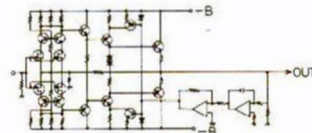

Input consists of super-low-noise FETs arranged in a parallel push-pull configuration, with DC servo feedback applied from output to input. This design provides an exceptionally high signal-to-noise ratio to the head amp for moving-coil cartridges.

## Noise Response of Head Amps for MC Cartridges

#### A-90's Head Amp

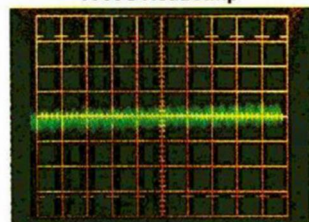

#### Conventional Head Amp

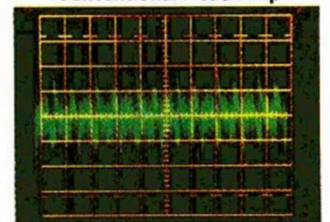



## A-90 DYNAMIC POWER NON-SWITCHING STEREO AMPLIFIER

### Our best, most powerful and most versatile model

You'll find the A-90 to be the most powerful and cleanest sounding amplifier you've even heard. It has power to spare — **continuous average power output of 200 watts\* per channel, min. at 8 ohms, from 20 hertz to 20,000 hertz with no more than 0.002% total harmonic distortion.** Even instantaneous response peaks, the kind you'll hear with Compact Discs, are reproduced without a hint of clipping; and during silent passages, you'll hear total silence, not a trace of noise to take away from your listening pleasure.

The secret is that the A-90 is our DC-servo Dynamic Power Non-Switching amplifier. Dynamic Power Supply provides low power supply voltage to the output transistors during soft passages for higher efficiency and reduced power loss. But when the sound becomes louder, the high voltage power supply comes into action to provide sufficiently high drive voltage to the output transistors, thus preventing clipping. The Dynamic Power Supply is twice as

efficient as conventional class-B amplifiers. This is why the A-90 can deliver a remarkable 200 watts per channel without strain, and without requiring a heavy duty heat sink or a huge power supply.

In the power amp section of the A-90, we use another Pioneer-exclusive feature, the Non-Switching configuration. With switching distortion completely vanquished and harmonic distortion almost nonexistent, music acquires a silkier and smoother quality. The combination of these technologies — the Dynamic Power Supply and the Non-Switching configuration — is only available from Pioneer, the world's leader in hi-fi technology.

Also responsible for the high power and low distortion of the A-90 is the use of the highest quality parts in the low-impedance power supply, such as a highly-regulated, low-stray flux toroidal transformer and eight filter capacitors with a total of 176,000 $\mu$ F capacitance.

The built-in pre-preamp for MC

cartridges uses super-low-noise input FETs. It generates so little noise that its signal-to-noise ratio of 74dB is almost the theoretical limit (76dB), according to the transistor thermal-noise theory. Unusual but useful is the Line Straight switch which, when used, allows the program signal to entirely bypass the tone control and balance potentiometers and the mode switch. A simpler signal path means purer ultimate sound quality.

Other features of the A-90 include: non-magnetic parts for lead wires and resistor caps to avoid magnetic distortion.

\*Measured pursuant to the Federal Trade Commission's Trade Regulation Rule on Power Output Claims for Amplifiers.



## A-70 DYNAMIC POWER NON-SWITCHING STEREO AMPLIFIER

### Simple operation, ample power and great looks

Newer music programs are offering an ever wider dynamic range, and this is why you need an amplifier with power to spare, an ability to respond to momentary power demands. The A-70 Dynamic Non-Switching amplifier was designed to tackle the critical problem of clipping at peak input levels. It provides **continuous average power output of 120 watts\* per channel, min. at 8 ohms, from 20 hertz to 20,000 hertz with no more than 0.003% total harmonic distortion.** Let's take a look at just how we've accomplished this remarkable feat.

First we've incorporated our Dynamic Power Supply. Using two level-adjusted high and low voltage power supplies, it reduces power loss during operation to one-half that of conventional class-B power amps. Therefore, efficiency is increased twofold. At most times, a low-level power supply feeds power to the output transistors. But the moment a musical peak appears, a high-voltage power supply is turned on. Thus,

clipping is avoided while sufficient driving voltage is supplied to the transistors during loud passages. A special feature called "high frequency on" ensures that high-frequency high-level signals, no matter how instantaneous, are reproduced with accuracy.

The power amp is also of the Non-Switching configuration, our exclusive design that prevents output transistors from switching off. Since transistors don't switch off, they don't create the switching distortion common to class-B amps. This winning combination of two exclusive technologies has made it possible for you to enjoy inordinately smooth sound at any listening level.

The A-70 is of the two-amp design. High-level inputs, such as from tape, tuner, or auxiliary equipment, are fed directly to the power amplifier. Phono inputs, including that from a low-level moving-coil cartridge, are amplified by a high-gain equalizer/amplifier. Simpler and shorter signal routes mean higher sound purity. The phono circuit uses

a low-noise dual FET input and a DC servo to achieve a high 70dB signal-to-noise ratio with moving coil cartridges.

You can enjoy the benefits of an even simpler and straighter signal path since we've provided the A-70 with a Line Straight Switch. It lets you bypass not only the tone control circuit but also the loudness circuit. Other features include LED peak power indicators and LED-equipped slider tone controls.

Designed to reproduce any program source with the lowest possible distortion

## A-60 DYNAMIC POWER NON-SWITCHING STEREO AMPLIFIER



- **Continuous average power output of 100 watts\* per channel, min. at 8 ohms, from 20 hertz to 20,000 hertz with no more than 0.007% total harmonic distortion.**

- **Dynamic Power Supply:** Improves power efficiency twofold for higher dynamic power during peak passages.

- **Non-Switching Power Amplifier:** Eliminates switching distortion and drastically reduces all other types of distortion.

- **DC-servo high-gain phono equalizer:** Features low-noise FET input and a DC servo, allowing the use of any popular types of cartridges, moving-magnet or moving-coil.

- **"Line Straight" switch:** Provides purest possible sound quality by bypassing tone controls and loudness switch.

- **LED indicators:** For "Line Straight," subsonic filter and input selectors (including tape).

- **Other features:** Subsonic filter, tape dubbing, A/B speaker drive, loudness.

A low-distortion amplifier with easy to use controls

## A-40 NON-SWITCHING STEREO AMPLIFIER

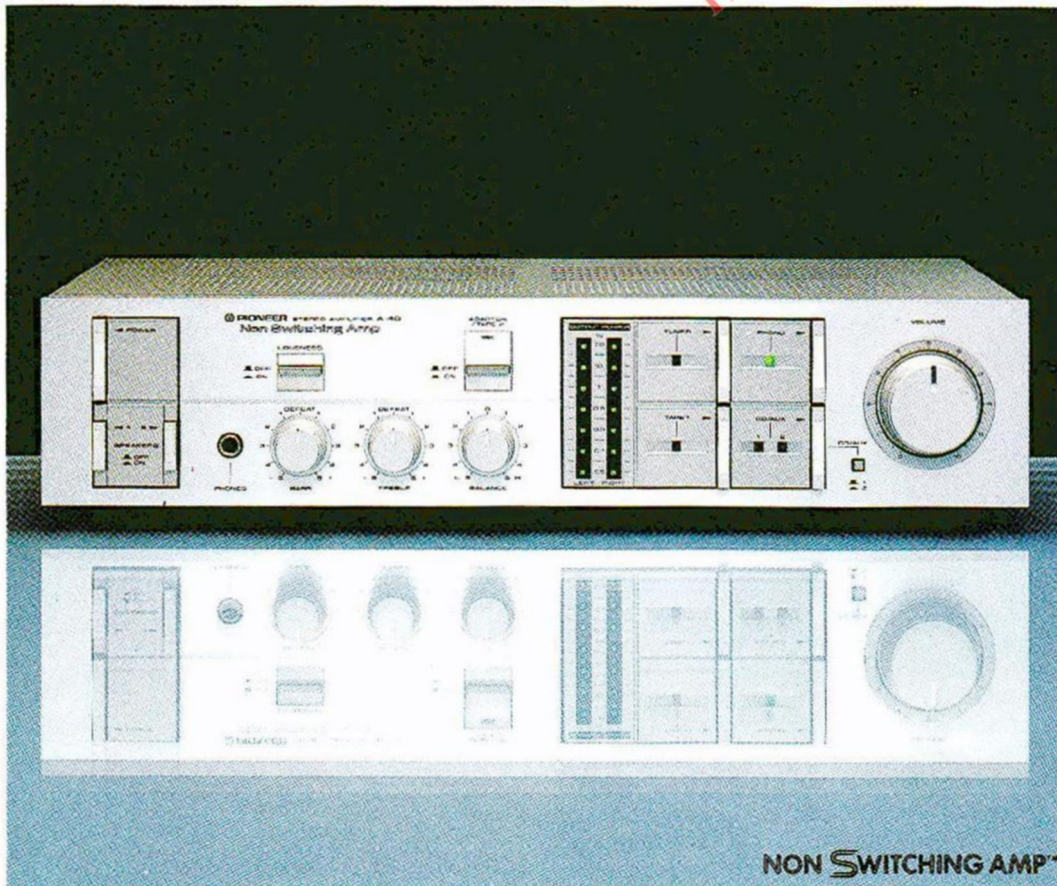

- **Continuous average power output of 70 watts\* per channel, min. at 8 ohms, from 20 hertz to 20,000 hertz with no more than 0.009% total harmonic distortion.**

- **Non-Switching Power Amplifier:** Eliminates switching distortion and drastically reduces all other types of distortion while retaining high efficiency.

- **Low-noise phono equalizer:** Features an FET input to assure wider dynamic range and lower distortion from any record.

- **LED indicators:** Include 7-segment power indicator for each channel and indicators for each input.

- **Other features:** Tape dubbing, A/B speaker drive, loudness.

# Pioneer Tuners

## The Technology

Pioneer tuners are at their best when conditions are not at their best: in urban areas where the airwaves are crowded with numerous stations and where interference and multipath are problems; and in rural, fringe reception areas where insufficient signal strength is the problem. Now, no matter where you live, you can enjoy best FM (and AM) reception, with least noise and distortion.

### Digital Direct Decoder gets to the root of the problem to eradicate noise and distortion

Figure 1 shows a simplified block diagram of a conventional tuner. An FM signal is detected and turned into an analog detector output. It then goes through an anti-birdie filter and then on to the multiplex decoder. Here, the signal is mixed with a subcarrier, consisting of a series of 38kHz

square waves, and then separated into left and right channel information. Throughout these stages, the signal is processed in analog form. Analog signals are easy prey to noise and distortion. Moreover, the anti-birdie filter, used to eliminate noise in the region beyond 53kHz, tends to take away part of the program signal and add distortion. Worse, the 38kHz subcarrier contains an infinite number of odd-order harmonics, which results in an increase in harmonic distortion. It's surprising that conventional tuners don't sound even worse than they do!

One solution has been the pulse count detector. Though it does treat signals in digital form during detection, in later stages digital signals are handled in analog form. Problems related with signals in analog form, anti-birdies and 38kHz square-wave subcarriers remain.

Look at figure 2. It's a diagram of our new F-90 tuner. Signals are turned into a

series of digital pulses by a pulse converter. And from then on they remain digital up until they reach the multiplex decoder, where an audio output is extracted from the mixture of digital program signals with a 38kHz sine-wave subcarrier. Therefore, signals are completely immune to contamination by noise and distortion. Absence of an anti-birdie filter means lower distortion. Furthermore, the subcarrier that is mixed with the program signal is a series of sine waves, a type of signal that contains only a fundamental frequency (38kHz) and no harmonics whatsoever.

The out-of-this-world specifications of the Pioneer F-90 tuner featuring a Digital Direct Decoder are truly spectacular: 0.0095% (mono) and 0.02% (stereo) distortion, 65dB stereo separation, 93dB S/N ratio (mono), and 85cB selectivity (400kHz, Narrow).

**Fig.1: Simplified Schematic Diagram of Conventional Tuner**

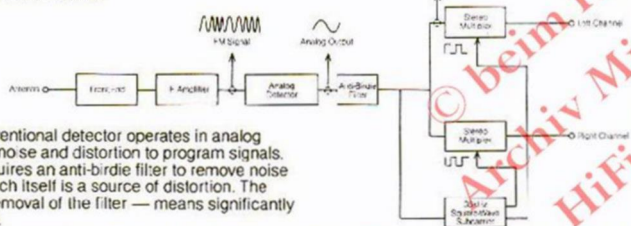

Because a conventional detector operates in analog fashion, it adds noise and distortion to program signals. Moreover, it requires an anti-birdie filter to remove noise over 53kHz, which itself is a source of distortion. The alternative — removal of the filter — means significantly increased noise.

**Fig.2: Simplified Schematic Diagram of Digital Direct Decoder**

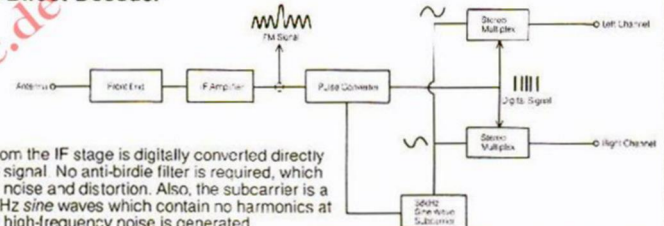

The output from the IF stage is digitally converted directly into an audio signal. No anti-birdie filter is required, which means lower noise and distortion. Also, the subcarrier is a series of 38kHz sine waves which contain no harmonics at all, hence no high-frequency noise is generated.

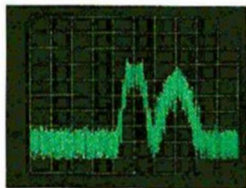

**(1) RF Input Waveform (98MHz center frequency, modulated 1kHz frequency)**  
This is the waveform of an FM input. The tuned frequency is 98MHz. As you see, it suffers interference from a neighboring station at 98.2MHz.

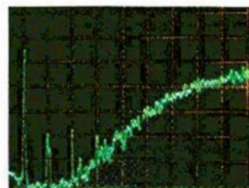

**(2) Frequency Spectrum of Detector Output**  
The L+R sum signal is seen at 1kHz, the pilot at 19kHz, and the subcarrier at 38kHz. The rising response beyond 38kHz reflects high-frequency noise.

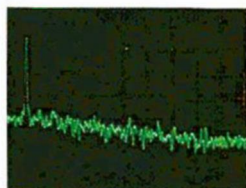

**(3) Frequency Spectra of Output**  
3-1 shows the output of a conventional tuner, and 3-2 that of the F-90. Each represents the frequency spectrum of the 1kHz input (shown in 1) after demodulation. You see, in addition to the desired input, a large amount of noise in 3-1, but little noise in 3-2.

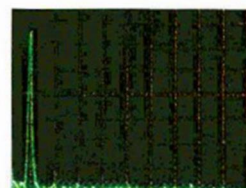

**(4) Waveform of Demodulated Output**  
4-1 is the demodulated output from a conventional demodulator, and 4-2 from the digital direct decoder. In 4-1 noise is apparent, but in 4-2 it's not.

**Ultra-Low Distortion — 0.0095% (mono), 0.02% (stereo)**

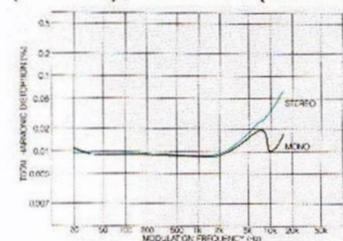

The F-90 offers record-low distortion for both mono and stereo FM.

**Ultra-Wide Channel Separation — 65dB**

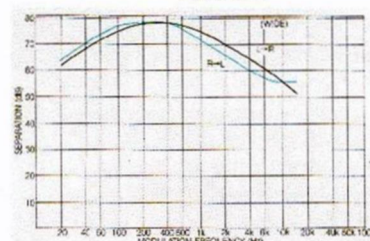

The F-90 delivers amazing 65dB separation at 1kHz, and 50dB over a range from 20Hz to 10kHz.

**Ultra-High Signal-to-Noise Ratio — 93dB (mono)**

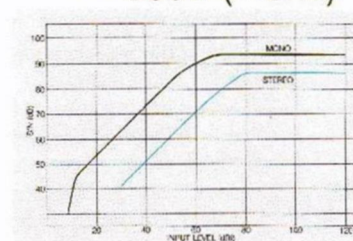

At 80dB input power, signal-to-noise is an astonishing 93dB (mono), and 86dB (stereo). Moreover, this high ratio is maintained over a wide input power range.

**Ultra-Sharp Selectivity — 85dB (400kHz)**

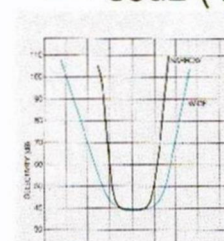

The F-90 has very high 85dB alternate channel selectivity. This figure is a measure of the extraordinary capabilities of the F-90.



## F-90 DIGITAL DIRECT DECODER TUNER

### A Digital Direct Decoder for truly spectacular specifications

The Pioneer F-90 is destined to change all preconceptions about tuners. Reading its specifications you might mistake them for those of a state-of-the-art amplifier. Especially amazing are its stereo separation of 65dB and its distortion of 0.0095% (mono). The reason for this new level of performance is the new Digital Direct Decoder. For details, please refer to the preceding page.

Other circuits of the F-90 offer capabilities far beyond those of nearly every other tuner on the market. A linear front end for FM improves RF intermodulation rejection in order to reduce interference ("ghosts") from neighboring stations. The result is low distortion in the front end. Another technology in the front end, an FET balanced mixer, assures high stability, while improving RF intermodulation and other interference rejection capabilities.

Linear amplification and a high signal-to-noise ratio are the characteristics of the tuner's detector. Here, we use a parallel

MOS FET at the input of the IF to achieve high gain and a high signal-to-noise ratio. Drift is banished and stability improved, for we use a precision crystal oscillator for the second mixer (1.26MHz). Reduced noise is another benefit of this second oscillator.

We've incorporated a useful feature into this tuner. To permit best possible reception at all times, we've included an IF bandwidth selector with two positions, WIDE and NARROW. Use WIDE for lowest distortion and best hi-fi sound, and NARROW to improve selectivity to minimize distortion resulting from interference. Either way, you'll enjoy the best possible sound, whatever the receiving conditions.

It goes without saying that the F-90 is a digital synthesizer tuner featuring drift-free performance. And for your convenience, it gives you presets for 8 FM and 8 AM stations for quick instant recall.

Other features are specially selected parts for better sound, fully static digital control for low noise, a record level

calibrator (Rec Level Check) for easy recording level adjustments on your tape deck, and a high-quality AM tuner section.

A slim, easy-to-use tuner featuring our top circuitry

## F-70 QUARTZ-DIGITAL SYNTHESIZER FM/AM TUNER

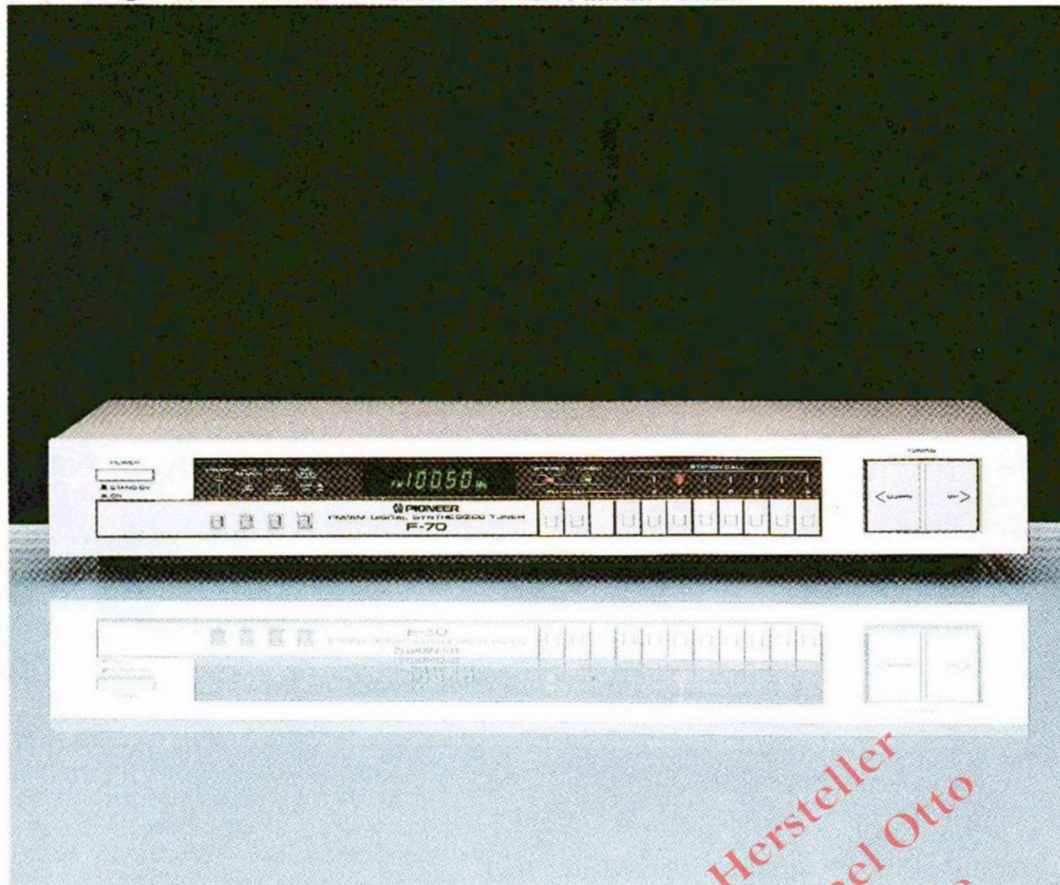

- **Front end featuring twin varicaps:** Reduces RF intermodulation and provides wider dynamic range. By effectively rejecting interference and image frequencies, performance is significantly improved, particularly in urban areas.
- **Digital synthesizer tuner:** Drift-free performance and pushbutton presets for instant recall of 8 FM and 8 AM stations.
- **“Pulse Swallow” frequency synthesis system:** Using an ultrasonic quartz-derived reference frequency, it contributes to the high signal-to-noise ratio (80dB for stereo, 85dB for mono).
- **“Direct-Through” multiplex demodulator:** Uses non-switching transistors for a clean stereo signal.
- **2 tuning modes:** Auto Search to automatically locate stations, Manual Search to check every frequency in preset intervals.

A boon to off-the-air recordists — a tuner with a built-in programmable timer/clock

## F-101T QUARTZ-DIGITAL SYNTHESIZER FM/AM TUNER

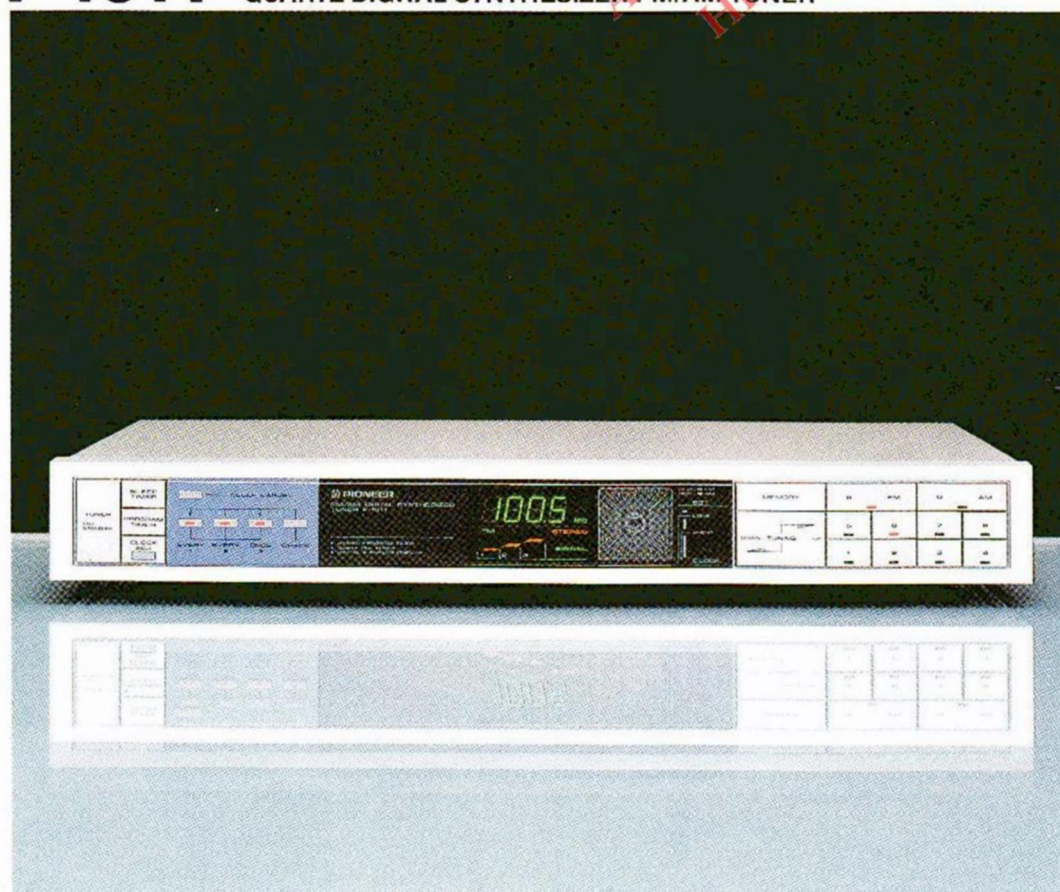

- **Programmable timer:** A microcomputer controls the timer so that the tuner and connected equipment turn on at preset times. Up to three operations a day — two daily and one one-time only.
- **Digital and analog clocks:** A colorful fluorescent panel shows time both in digits and by hands. The digital display doubles as a frequency display for the tuner.
- **Digital synthesizer tuner:** For top tuning accuracy and presets of 8 FM and 8 AM stations.
- **Timer setting indicator:** Preset times are shown by lights ringing the analog clock.
- **Sleep timer:** Set in 10-minute increments for up to 24 hours.
- **Last channel memory:** FM and AM stations last tuned are automatically tuned the next time the unit is turned on.
- **Memory backup for station frequencies.**

# Pioneer Cassette Decks

## The Technology

With the arrival of the digital audio age, we decided that it was an opportune time to go back to the basics and "rethink" the cassette deck. Our intensive study into every aspect of cassette deck design culminated in the development of the most highly sophisticated decks we have ever offered: models CT-A9 and CT-A7, each featuring our new "Reference Master Mechanism." For the first time, cassette deck performance has been brought up to the exacting standards of digital audio. We expect models CT-A9 and CT-A7 to become the benchmarks by which all other cassette decks are judged.

### Staggered-resonance closed-loop dual-capstan drive

Tape tension variations, tape skew, tape speed variations, etc., are the factors that prevent the tape from smoothly and accurately running across the heads. Of all tape drive designs presently known, the closed-loop dual-capstan drive is considered to be most effective in assuring smooth and precise tape flow. It uses two pinch rollers and two capstans to provide uniform tape speed and tape tension.

In the CT-A9 and CT-A7, we use a highly sophisticated version of the closed-loop dual-capstan drive system — we call it the "Reference Master Mechanism." In our

version, the two capstans differ in diameter (and, therefore, in rotation speed) as do the two matched pinch rollers. Peaks in wow and flutter are thus staggered so as not to excite resonance. The result is record-low wow and flutter — only 0.018% (WRMS) in the CT-A9. Since tape tension is uniform, modulation noise and level variations are also reduced.

To assure accurate tape traction and prevent tape slippage, the perimeter surface of the capstan is given what we call an "FS finish." It further reduces wow and flutter, modulation noise, output variations and dropouts to inaudible levels.

In summary, the Pioneer "Reference Master Mechanism" results in sound that is completely devoid of fuzziness and muddiness. Transients are reproduced faithfully, dynamic range is extended, while noise is essentially eliminated. It's sound realism's finest hour.

### Precision tape transport and head block assemblies

In our "Reference Master Mechanism," no part is permitted to vibrate during operation. The main chassis is a thick steel plate about 2.5 times as resistant to bending as the chassis of lesser decks. The head block consists of two pieces of die-cast zinc that are mounted on the mechanism base. When

mounting the head block on the chassis, we use optical instrumentation to avoid even the minutest alignment discrepancy. Our attention to detail ensures that the tape runs smoothly across the heads, with as little skew, phase variation and azimuth misalignment as technically possible.

### 4-bit microcomputer control for smooth, accurate and silent operation

The tape transport mechanism in the CT-A9 and CT-A7 operates under supervision of a 4-bit microcomputer. Working in combination with a device called an "absolute encoder," it accurately controls the DC motor through a digital feedback system. The encoder monitors the positions of all mechanical parts of the deck, and transmits this information to the computer. The computer then times and coordinates everything — power to the reel motor, the cutting in of the muting circuit, etc. — down to the split second for smoothest possible operation. Since no plungers are used, the mechanism works with total silence. Microcomputer control also means simplified operation. For instance, when you place a tape into the cassette compartment, the door closes, the tape is positioned and tape slack is taken up — all automatically thanks to our "Auto Loading."

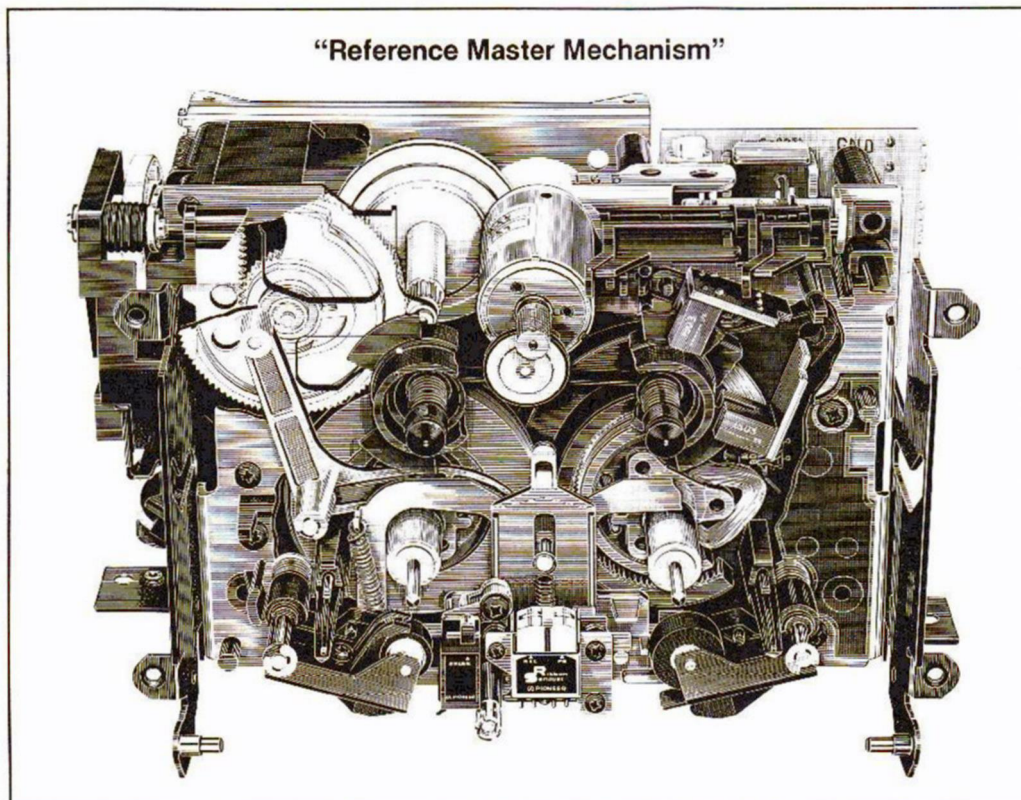

● Level Variation (10kHz)

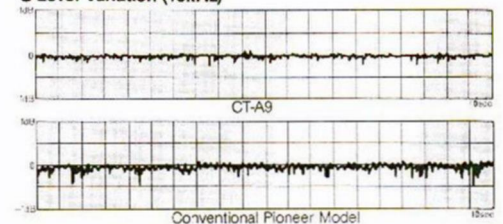

● Phase Variation (10kHz)

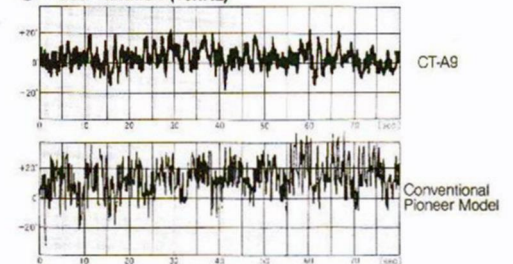

● Frequency Analysis of Wow & Flutter Components

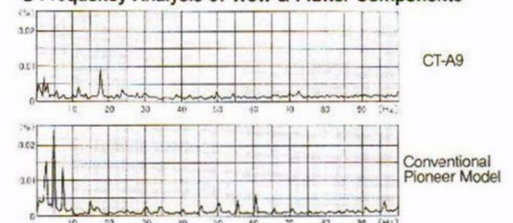

## Ribbon Sendust Heads for wide dynamic range

Pioneer's top cassette deck models utilize Ribbon Sendust recording and playback heads. In the cores of these heads are used thin sendust "ribbons," manufactured by an exclusive high technology process that successfully overcomes the material's natural inductivity.

The Pioneer Ribbon Sendust head boasts extremely low core loss (for extended high-frequency response), high playback sensitivity and low tape friction noise (for a better signal-to-noise ratio), and high saturation magnetic flux density (for higher output in the low-to-mid range). Moreover, distortion, particularly of harmful 3rd harmonics, is drastically reduced too. Cassette tapes have never offered more extended or more dynamic performance.

In our highest performance decks (CT-A9 and CT-A7), our sendust heads offer yet another refinement. The gap for the playback head has been reduced to a narrow  $0.6\mu\text{m}$ , thereby improving high-frequency response by about 1.5dB. The heads are also driven at lower impedance so that transient response is improved.

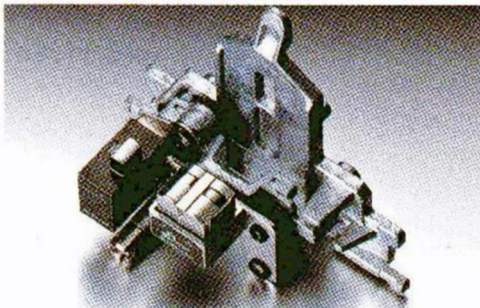

## Three-head design with record/playback heads mounted in a single precision housing

A record head needs a wide gap to avoid saturation, while a playback head requires a narrow gap for extended flat response. So using the same head for recording and play is a compromise at best.

In our top three models (CT-A9, CT-A7 and CT-90R), however, we use three separate heads for recording, playback and erasure, giving each the optimum gap width for its specific function. That's why playback response of these decks is wide and extended and why distortion is low.

We have fitted the record and play heads in a single precision housing to ensure that the head gaps remain perfectly parallel with each other. The design keeps azimuth error, crosstalk and response irregularities to a minimum.

## Advanced auto-reverse mechanism with swivel record/play heads

The CT-90R and CT-70R are our high-performance auto-reverse models. In these decks, the housing that holds the record and playback heads swivels 180 degrees inside a micro-precision head holder when the tape reaches the end. It turns smoothly with almost no measurable friction or play thanks to a special lubricant lining.

Since the same heads and electronics are used for both sides of a tape, response and output remain the same. And since the heads are precision aligned with each other before mounting in the head housing, azimuth error cannot occur. Thanks to an LED sensor system for tape-end detection, the tape quickly changes direction the moment the tape/leader joint appears.

## Computer controlled transport featuring 3 direct-drive motors

In the CT-90R and CT-70R, three direct-drive motors are used. One directly drives the capstan (in the forward direction) and the other two drive the reels. This simplified mechanism requires no belts or idler wheels to reduce speed or transmit power, and therefore offers higher accuracy and reliability. Controlled by a microcomputer, these motors operate in perfect harmony, providing a number of automatic operations. Finally, these motors are our own coreless DC-servo Hall types, renowned for their highly precise and smooth operation.

## Pioneer's C.A.C. — Computer-Aided Convenience

**Blank Search** — Lets you easily dovetail the end of a previous program with the beginning of a new one. The break between the new and old recordings is automatically set at four seconds.

**Index Scan** — Lets you automatically sample the first seven seconds or so of each selection on the tape, one right after another.

**Blank Skip & Reverse** — Lets you skip long blanks on tapes during playback, and go quickly to the next song. Blank Skip & Reverse even lets you skip blanks at the end and beginning of a tape, as the tape reverses direction.

**Music Repeat** — Lets you repeat one selection, or entire selections on both sides of a tape, over and over again, up to eight times.

**Real Time Counter** — Displays the amount of tape remaining on the supply reel in real-time minutes and seconds.

## Automatic BLE Tuning System with MOL Balance

Each tape has specific electromagnetic characteristics, the most important of which are bias, level and equalization. Together they determine overall frequency response, flatness of high-frequency response, and distortion.

For this reason, Pioneer developed the Automatic BLE Tuning System. It *automatically* measures the characteristics of a tape in use and chooses the optimum values of bias, level and equalization. A 4-bit micro-computer is at the heart of the system, and it takes no more than a few seconds to optimize any tape.

Now we have made our Auto BLE Tuning System even more sophisticated and incorporated it into our top model, the CT-A9. It has what we call "MOL Balance." MOL stands for Maximum Output Level, the recording level at which distortion does not exceed 3 per cent. Beyond that level, distortion becomes so predominant that listening is unbearable. Also, MOL is frequency-dependent.

MOL Balance simply lets you adjust bias so as to maximize MOL depending on the type of music being recorded. It offers three choices — PEAK BIAS, OVERBIAS and UNDERBIAS. PEAK BIAS offers a flat MOL over a wide range, which is similar in response to the frequency spectrum of pop, rock and vocal music. UNDERBIAS offers a high MOL at higher frequencies; it has a response similar to the frequency spectrum of synthesizer music. Conversely, OVERBIAS has a higher MOL at low-to-mid frequencies, a response close to the spectrum of classical materials.

So by choosing the right MOL for the type of music you're going to record, you're assured of the widest possible dynamic range from each and every tape. And Auto BLE makes sure that correct equalization is applied for flat overall response.

Frequency Spectra of Typical Music Sources and Tape's MOL Response

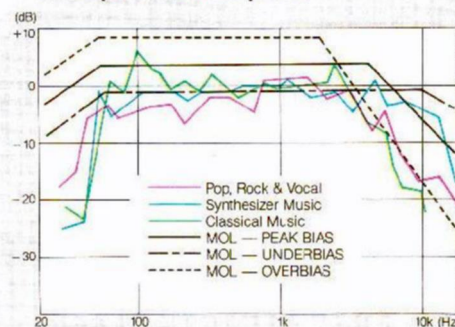



## CT-A9 3-HEAD CASSETTE DECK WITH "REFERENCE MASTER MECHANISM"

### The new reference standard by which all other decks should be judged

In designing the CT-A9 our engineers pulled out all the stops. The result is a deck that is *audibly* better — wow and flutter lower than any other deck in existence, almost no noise or distortion, ruler-flat response and, best of all, superb sound.

The tape drive system in the CT-A9 we proudly call our "Reference Master Mechanism." It uses a Pioneer-perfected closed-loop dual-capstan drive system that drastically reduces modulation noise and level variations. The capstan is driven directly by a Quartz-PLL servo motor, and the overall result is dramatically reduced wow and flutter of a barely measurable 0.018% (WRMS). The entire mechanism is under the competent control of a 4-bit microcomputer and absolute encoder that coordinates and times the mechanism for sure, silent and reliable operation.

The CT-A9 uses newly redesigned Ribbon Sendust heads. In addition to the standard advantages of Ribbon Sendust including extended high-frequency response,

this new low-impedance head design offers an even better signal-to-noise ratio and wider dynamic range. Two Ribbon Sendust heads are used in the CT-A9, one for recording, the other for playback. In this way, each is provided with an optimal head gap.

The CT-A9 features the latest amplifier technology as well. For instance, a DC playback equalizer is directly coupled with the head using no capacitors. This minimizes coloration, while improving transient response. Only specially selected components are used for the electric circuits of the CT-A9, including audio-use capacitors and metal film resistors.

The Pioneer Auto BLE (Bias, Level and Equalization) system now features MOL balance. Like standard BLE, it automatically adjusts bias, level and equalization so that every tape delivers wide, flat frequency response, low distortion, and accurate Dolby tracking. The new version, additionally, lets you optimize MOL (Maximum Output Level) by means of three switches. It lets you enjoy

a wide dynamic range from any material you record — electronic music, pop (rock) or classical.

The CT-A9 is designed for simple operation too. Auto Loading automatically closes the door to the cassette compartment and takes the slack out of the tape. Power Eject stops the tape, automatically opens the cassette compartment, and pushes the tape up. Tape Return stops the tape when the counter reads "0000" in either the FF or Rew mode. Auto Monitor lets you hear SOURCE when the deck is in record standby, and TAPE while recording.

Other features: Dolby\* B/C NR, MS (Music Search), tape/remaining-time counter, auto tape selector, timer standby, auto record mute, master level control with L/R level presets, and 35-segment fluorescent level meters with overrecording warning for each tape type.

(Note: Auto Tape Loader may not work when the cassette shell is transparent.)

\*Dolby and the double-D symbol are trademarks of Dolby Laboratories Licensing Corporation.



## CT-A7 3-HEAD CASSETTE DECK WITH "REFERENCE MASTER MECHANISM"

### Exciting new features plus extraordinary performance

The CT-A7 has many of the same features as our reference standard CT-A9, including the "Reference Master Mechanism" and the new Ribbon Sendust Head. This means that only one other deck we know of can outperform the CT-A7, and that's the CT-A9. Yet for all these features and performance, the CT-A7 won't cost you as much as you think.

The "Reference Master Mechanism" is our sophisticated closed-loop dual-capstan drive. It employs two capstan/pinch roller sets to ensure that the tape running across the heads is taut. Since the capstans (and pinch rollers) have different diameters and run at different speeds, they provide constant tape tension for better tape-to-head contact. And since they have staggered peaks in their wow and flutter response, resonance is damped. Advantages of our sophisticated drive mechanism are many: wow and flutter, modulation noise, level variations and dropouts are all dramatically reduced for audibly better sound. Further,

the mechanism is controlled by a 4-bit microcomputer and absolute encoder, for foolproof, reliable operation.

As in the CT-A9, our new low-impedance Ribbon Sendust Head is featured in the CT-A7. It offers good high-frequency response, high sensitivity, high MOL and low distortion across the entire frequency range. Two are used in the CT-A7 in our discrete 3-head design, one for record and one for play. They are mounted in the same housing and precision adjusted for low azimuth error. Crosstalk and "crossfield" (mutual interference between heads) are greatly reduced. The playback head is direct coupled with the DC amp for clearer reproduction.

The CT-A7 is easy to operate too. Just slip a tape into the well; the tape loads itself into the deck automatically and tape slack is taken up. Touch the Eject button even during play and Power Eject stops the tape and rejects it automatically. Touch the Tape Return button during FF or Rew and the tape stops when the counter reads "0000."

Auto Monitor lets you hear SOURCE when the deck is in record standby, and TAPE while recording, also automatically. Auto Record Mute creates 4-second blanks and stops the tape at the touch of a button.

Other features include: Dolby B/C NR, MS (Music Search), 4-digit electronic tape counter, auto tape selector, timer standby, and 18-segment fluorescent level meters with overrecording warning for each tape type.

(Note: Auto Tape Loader may not work when the cassette shell is transparent.)



\*Remote control unit JT-216 is optional.

## CT-90R 3-HEAD AUTO-REVERSE RECORD AND PLAY CASSETTE DECK

### Auto-reverse convenience, 3-head precision, tape tuning accuracy, computer facility

The CT-90R, our best auto-reverse cassette deck, has every feature to make possible what was previously thought of as impossible. In our Ribbon Sendust head, for instance, wide dynamic range is made compatible with extended frequency response; our unitized swivel heads offer both accurate 3-head performance and auto reverse convenience. (Off-the-tape monitor is not possible.)

For record and play, we use our own Ribbon Sendust heads that are precision mounted in a single housing. Since they are separate, they each have been given optimum gap widths — wide in the record head for high sensitivity and low distortion, narrow in the play head for extended frequency response. Perfectly aligned gaps reduce azimuth error, so there is little crosstalk and degradation of sound.

The reverse mechanism for the heads uses a swivel design, featuring smooth

action, low noise, and the ability to provide the same excellent response and output level from both tape sides. Reverse action is quick because an LED sensor is used to detect the leader tape; the moment the leader is detected, the tape transport changes the tape running direction.

The tape transport is highly sophisticated and simplified for better performance. It uses three direct-drive motors, each our own smooth, cog-free coreless Hall design for low wow and flutter. They are controlled by a microcomputer to provide a number of convenient automatic operations — what we call C.A.C. (Computer Aided Convenience). These include Blank Search, Index Scan, Blank Skip & Reverse, Music Repeat, and a Real Time Counter, all described in the introductory pages.

Another computer technology we use in the CT-90R is the Auto BLE system that automatically adjusts Bias, Level and Equali-

zation so that the full potential of each and every tape may be realized. It only takes eight seconds for Auto BLE to give you wide and flat frequency response, low distortion, and accurate response from Dolby recording — all automatically with the touch of just one button.

Dolby C noise reduction gives remarkably clear sound and wide dynamic range. Such side effects as breathing and noise modulation are suppressed to such an extent that they are hardly audible.

A deck for the audio purist

# CT-70R

3-MOTOR AUTO-REVERSE RECORD AND PLAY CASSETTE DECK



\*Remote control unit JT-216 is optional.

● **Auto-reverse record and playback:** Use of a precision swivel record/playback head means reliability, durability and matched response and output from both sides of a tape.

● **Three microcomputer-controlled direct-drive motors:** Brushless DC-servo Hall types, offer smooth, no-cog rotation. Computer controlled to provide extra convenience.

● **Ribbon Sendust Head:** Provides high signal-to-noise ratio, wide dynamic range and excellent high-frequency response. A perfect match for metal tapes.

● **Computer-Aided Convenience:** Included are Index Scan, Blank Search, Blank Skip & Reverse, Music Repeat.

● **Dolby C-type noise reduction system:** Reduces noise by 19dB at 5kHz, for wide range and low-noise tape sound.

● **Other features:** Dolby B noise reduction, 4-digit electronic tape counter, 12-segment LED peak level meters, auto tape selector, remote control terminal, timer standby, one-touch recording, record mute, memory stop.

An easy to use deck with fine performance and auto-reverse convenience

# CT-50R

AUTO-REVERSE CASSETTE DECK



\*Remote control unit JT-217 is optional.

● **Quick auto-reverse record/play:** Tape transport reverses itself so quickly, almost no interruption in the music is noticeable.

● **IC full-logic tape transport:** For comfortable touch operation and direct mode change.

● **Dolby C-type noise reduction system:** Reduces noise by 19dB at 5kHz, for wide dynamic range and low-noise tape sound.

● **Music Search/Skip:** Lets you automatically go back to the beginning of the song currently playing, or jump ahead to the beginning of the next one. Also lets you skip long blanks on tapes and go quickly to the next song.

● **Other features:** Dolby B noise reduction, LED peak level meters, auto tape selector, remote control, timer standby, record mute.

The programmable double cassette deck

# CT-1050W

DOUBLE CASSETTE DECK

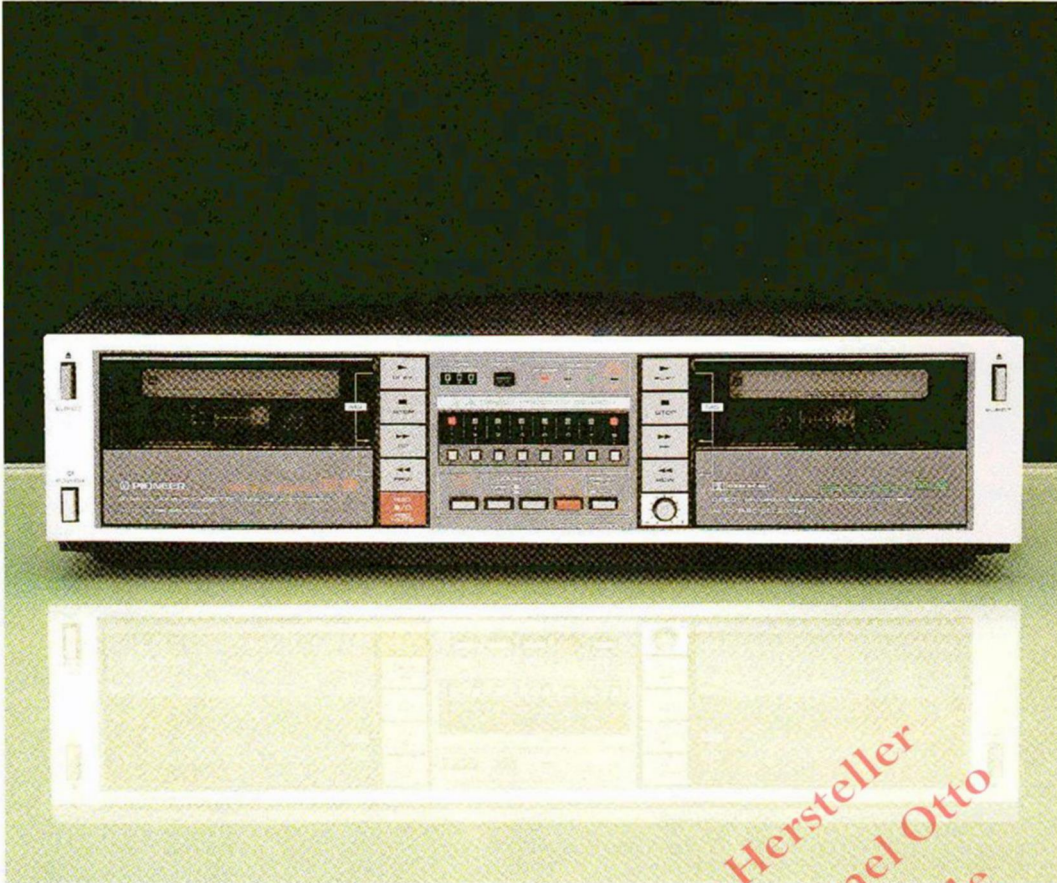

● **Easy dubbing:** you can dub from one tape to another with one-touch ease.

● **Direct program search:** Lets you select up to 16 songs and program the order in which they are played back.

● **Random auto edit:** Lets you automatically record programmed songs in programmed order at the touch of a button.

● **Relay play:** Lets you automatically play two tapes, one right after the other, in relay fashion.

● **Dolby C-type noise reduction:** Reduces noise by about 19dB at 5kHz, for wide dynamic range and low-noise tape sound.

● **IC full-logic tape transports:** For comfortable touch operation and direct mode change.

● **Other features:** Dolby B noise reduction, auto tape selector, timer standby, pitch control (on play-only transport), record mute.

Dubbing and Relay Play are two exciting new features

# CT-1040W

DOUBLE CASSETTE DECK

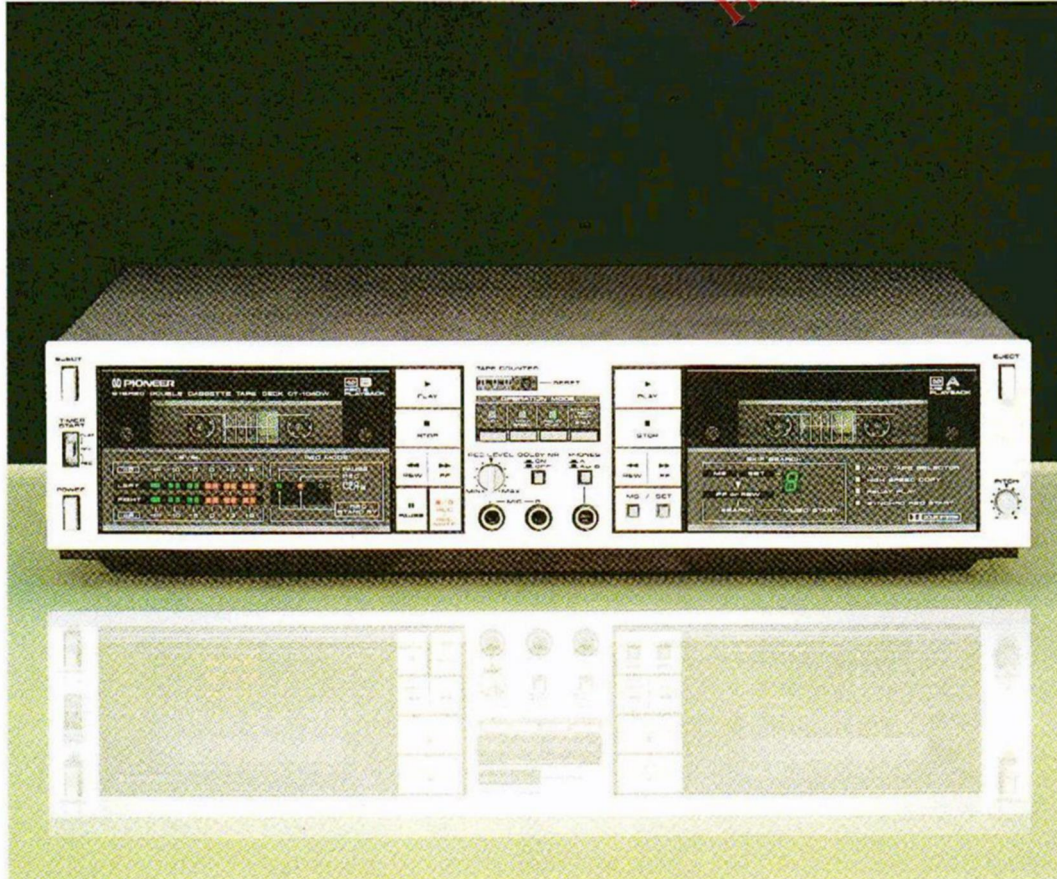

● **Easy dubbing:** You can easily dub tapes at normal or double speed.

● **Skip Search:** Lets you zero in on and play a song up to 9 ahead, or 8 behind.

● **Synchro recording:** At the touch of a button, both decks start in synchronization — one playing, the other recording.

● **Relay play:** Two tapes are played one right after another in relay fashion.

● **Other features:** IC full-logic tape transports, Dolby B noise reduction, LED level meters, auto tape selector, timer standby, pitch control (on play-only deck), record mute.

For those who care about the sound of their music

# CT-40

STEREO CASSETTE DECK



● **IC full-logic tape transport:** For comfortable touch operation and direct mode change.

● **Dolby C-type noise reduction system:** Reduces noise by 19dB at 5kHz, for wide dynamic range and low-noise tape sound.

● **Skip Search:** Lets you zero in on and play a song up to 9 ahead, or 8 behind.

● **Electronic 4-digit tape counter:** Offers finer resolution to make indexing easier.

● **One-touch recording:** Just a touch of the RECORD button is all that is necessary to start recording.

● **Other features:** Dolby B noise reduction, LED level meters, timer standby, record mute.

The user-friendly cassette deck

# CT-501

STEREO CASSETTE DECK



● **Soft-touch tape control:** For velvet-smooth operation.

● **Dolby C-type noise reduction system:** Reduces noise by 19dB at 5kHz, extending the usable dynamic range considerably.

● **One-touch recording:** Just a touch of the RECORD button is all that is necessary to start recording.

● **Tape selectors:** Provide positions for all popular tape types — metal, chrome and normal-bias.

● **LED level meters:** Facilitate the making of tapes with minimum noise and distortion.

● **Timer standby:** Permits off-the-air recording in absentia.

● **Dolby B-type noise reduction.**

© beim Hersteller  
Archiv Michael Otto  
HiFi-Classic.de

Every necessary feature for great taping results

# CT-301 STEREO CASSETTE DECK



- **Soft-touch tape control:** For velvet-smooth operation.
- **Dolby B-type noise reduction system:** Renders tape hiss nearly inaudible, even during the softest passages.
- **One-touch recording:** Just a touch of the RECORD button is all that is necessary to start recording.
- **Tape selectors:** Provide positions for all popular tape types — metal, chrome and normal-bias.
- **LED level meters:** Facilitate the making of tapes with minimum noise and distortion.
- **Timer standby:** Permits off-the-air recording in absentia.



## RT-909 AUTO-REVERSE OPEN-REEL TAPE DECK

The professional sound of open reel

- Precision closed-loop dual-capstan 3-motor drive system.
- Four-head design with monitor capability.
- Auto-reverse playback with infinite repeat.
- Accepts up to 10-1/2-inch reels for hours-long recording.
- Symmetrical tape path for better tape-to-head contact.
- Touch operated logic control tape transport.
- Professional specs: Frequency response from 20Hz to 28kHz ( $\pm 3$ dB), signal-to-noise ratio better than 60dB, wow and flutter less than 0.04% (WRMS).
- Fluorescent peak level indicator, independent bias/EQ selection, pitch control, timer start, microphone/line mixing.

\*Comes with one reel.

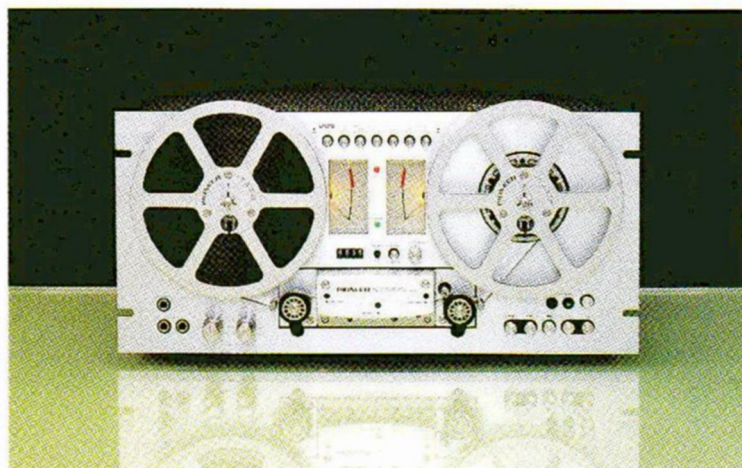

## RT-707 AUTO-REVERSE OPEN-REEL TAPE DECK

The choice of demanding audiophiles

- Precision closed-loop dual-capstan 3-motor drive system.
- Four-head design with monitor capability.
- Auto-reverse playback with infinite repeat.
- Accepts up to 7-inch reels for hours-long recording.
- Symmetrical tape path for better tape-to-head contact.
- Touch operated logic control tape transport.
- Superb specs: Frequency response from 30Hz to 24kHz ( $\pm 3$ dB), signal-to-noise ratio better than 58dB, wow and flutter less than 0.05% (WRMS).
- Vertical VU meters, pitch control, independent bias/EQ selection, microphone/line mixing.

\*Comes with one reel.

# Pioneer Turntables

## The Technology

If you feel that playing records on a turntable involves too much trouble and too much care, you haven't seen Pioneer's new lineup of turntables. Each is easy to use, and most are fully automatic with pushbutton operation. All are designed not only for smooth operation but also for excellent sound reproduction. We care about sound, so should you. Here are some of Pioneer's newest technologies that help give you *great* sound.

### Dynamic Resonance Absorber for better yet performance from our low-mass PG\* tone arms

As any audio pundit knows, the mission of a tone arm is to allow the cartridge to faithfully follow the record groove, extracting signals incised on the groove walls, yet without picking up extraneous vibration. Yet most tone arms excite resonance to such a degree that vibration, even slight, is inevitable, resulting in more distortion and coloration in the reproduced sound.

For this very reason, we conducted in-depth research into tone arm resonance. Some of the processes we used in our

studies included computer simulations and computer analysis (Fast Fourier Transform technique, for instance). We now feel that we know more about this persistent phenomenon than anyone else. The proof is the DRA, or Dynamic Resonance Absorber, we recently developed for our turntables.

The DRA is a complex resonator that is fitted on the tone arm shaft. It consists of an optimally viscous damper and a weight. Every time the tone arm is moved by a positive force caused by vibration or resonance, it applies a compensating negative force. In other words, the device absorbs any vibration applied to the tone arm. The result is that the stylus at the tip of the arm picks up only the signals in the groove. So completely are spurious signals caused by vibration and resonance eliminated that they are no longer of any concern. The end to the problem of vibration and resonance means clearer sonic imaging and richer, tighter reproduction.

The arm to which we fit the DRA is special too: It is constructed out of a Pioneer-exclusive material we call Polymer Graphite or PG. It has low mass, and high rigidity and internal loss. Therefore, it is

more resistant to resonance and has less apparent sound of its own than most other tone arms made of, for instance, aluminum. Again, in deciding on PG, designing the arm contour, and determining optimum weight distribution, we were aided by our powerful computer analysis system.

(\*PG (Polymer Graphite) is a trademark of Pioneer.)

### Stable Hanging Rotor\* for smooth motor rotation

The motor in every one of our turntables uses a Stable Hanging Rotor. This design places the fulcrum of the motor immediately below the platter on a truncated spindle. The fulcrum exactly coincides with the center of gravity of the platter. As a result, spindle wobble is eliminated; and loss of momentum due to spindle slippage is avoided.

(\*Stable Hanging Rotor is a trademark of Pioneer.)

### Construction of Dynamic Resonance Absorber

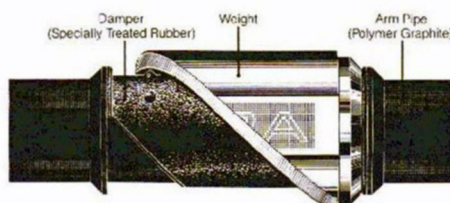

### Tone Burst Input/Output Response

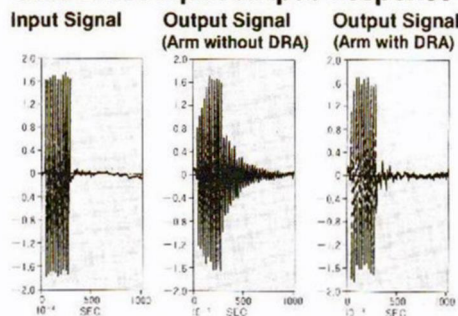

A series of ten 400Hz sine-wave signals (tone bursts) from the DA converter of a computer is used as a source of vibration (left trace). This vibration is applied to two tone arms, one with the Pioneer Dynamic Resonance Absorber, and one without. The output of each tone arm is then measured.

As you see in the right trace, the output from the DRA-fitted tone arm is a very close approximation of the input signal. Both its attack and decay responses are fast. But the response of the tone arm lacking the DRA (center trace) does not closely resemble the input signal. Both attack and decay responses are not quick enough.

### Three-Dimensional Cumulative Impulse Response

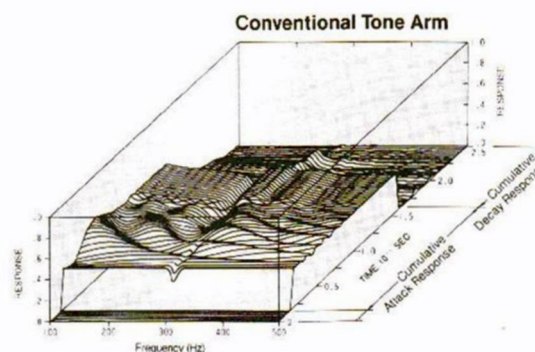

3-dimensional cumulative impulse response depicts how a tone arm responds to a 0.24-second pulse. Response is sliced into 40 equal sections, timed from the moment the pulse is first applied. Response is shown in three dimensions with frequency, response (level) and time as parameters.

Cumulative attack response lets you know how the tone arm responds to a pulse from the moment when it is applied to the moment when the arm reaches a steady state. The fewer violent undulations it contains, the better response is.

Cumulative decay response is indicative of how the tone arm responds from the moment a pulse is cut off to the moment when the arm reaches a steady state. Ridges in the response are proof that the tone arm is resonating mechanically at the frequency where these ridges lie. To your ears, resonance is heard as a lingering tone even after the signal is no longer being applied.

The response of a tone arm fitted with the Dynamic Resonance Absorber contains fewer undulations than does that of an arm without the DRA, and the undulations themselves are low and smooth. In addition, there are no clear ridges seen in the chart — proof that it performs far better than the conventional tone arm.

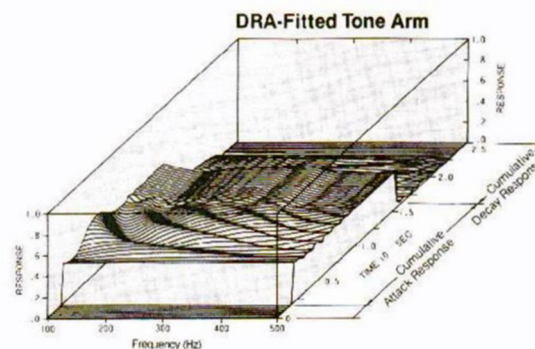

## Quartz-PLL servo with Periphery Integration and coreless motor — for utmost speed stability and accuracy

In our turntables we use precision motors — coreless servo motors. Their designs don't call for the use of cores or slots, therefore small speed deviations known as cogging are completely banished, for smooth, ripple-free rotational torque. This provides our coreless servo motor with a high signal-to-noise ratio and low wow and flutter. Moreover, switching of magnetic poles is accomplished by semiconductor Hall elements, not mechanical brushes, leading to a total absence of switching noise.

And in all our turntables except models PL-S30 and PL-44FS, the motors are controlled by a highly precise speed control system — a Quartz-PLL servo with Periphery Integration. This system compares a reference signal from a quartz crystal oscillator for phase difference with a speed-proportional signal from a speed-detector system in the motor. Any difference in phase, which represents speed error, is compensated for instantly, locking the platter speed with the quartz signal in the PLL (Phase-Locked Loop) circuitry.

To obtain the speed-proportional signal from the motor, we've employed another elaborate device — the Periphery Integration system. It utilizes magnetic poles printed on the underside of the rotor magnet housing and the coils printed on the circuit board to generate hundreds of pulses every rotation that are compared with the quartz reference frequency. Its effectiveness lies in its uncanny responsiveness to changes in dynamic loading conditions due to warps, eccentricities, etc.

## Construction of Coreless Direct Drive Motor

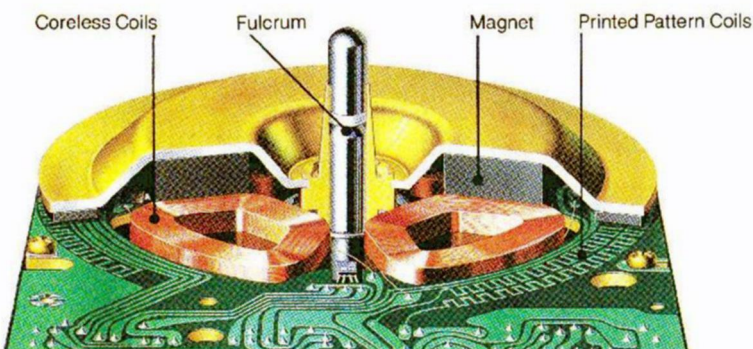

Vibration Attenuation Response of Tubular PG Tone Arm

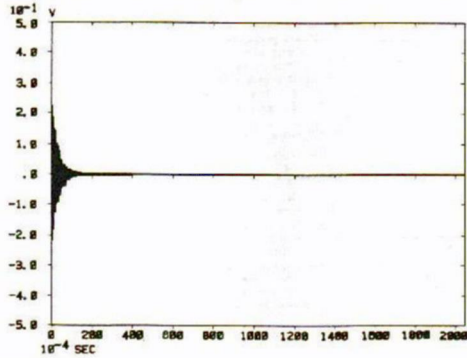

Vibration Attenuation Response of Tubular Aluminum Tone Arm

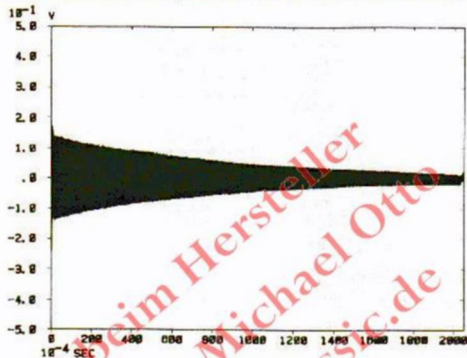

The material used in the construction of a tubular tone arm should have high strength and demonstrate high internal loss. In measuring internal loss, each material is struck by a hammer. Vibrations caused by this shock are converted into an electrical voltage. Thus, the width of the attenuation response is proportional to the amount of voltage generated by the shock-induced vibration. Pioneer's PG tone arm, because of its high internal loss, quickly attenuates spurious vibrations; they can't muddy sound quality.



## Pioneer turntables mount both plug-in and universal type cartridges

Pioneer turntables come equipped with a universal type headshell that mounts any of the many hundreds of cartridges currently on the market. In addition, except for the PL-L800S, PL-88FS and PL-44FS, they all include a new plug-in cartridge connector that accepts quick-mount snap-in type cartridges.



This is the standard logo mark for the plug-in cartridge connector system. Any cartridges carrying this mark are compatible with any turntables or tone arms carrying the same mark.



## PL-707 QUARTZ-PLL FULLY AUTOMATIC TURNTABLE

TAD

PG  
POLYMER GRAPHITE

### A turntable that places sound quality first

This is a turntable we are rightfully proud of, and if you own one you'll know why. It features our latest technology in all areas of turntable design, not the least of which is the new DRA, or Dynamic Resonance Absorber.

A result of extensive computer modal analysis, the DRA eliminates a type of resonance that conventional tone arm designs cannot. It permits the arm to accurately extract information from the record groove for better clarity and finer definition.

The tone arm on which the DRA is fitted is made of a Pioneer-exclusive material known as PG, or Polymer Graphite. Rigid, lightweight and able to quickly disperse vibration, it has made resonance — and mistracking caused by it — a worry of the past.

The PL-707 is easy to use, for it features microcomputer controlled fully automatic operation. A separate motor is used for the tone arm that is under the control of a computer, as is the platter motor. The computer is responsible for changing speeds, stopping the motors and moving the tone arm. Operation is dependable and fail-safe. If, for instance, you try to play a record before you unclamp the tone arm, no harm will be done because the computer will countermand the play command you've given.

For utmost rotational accuracy and smoothness, the platter of the PL-707 is driven directly by our Quartz-PLL coreless motor with Stable Hanging Rotor. Since cogging and fluttering are eliminated, the motor boasts very low wow and flutter, along with

a very high signal-to-noise ratio.

We've extended our anti-resonance philosophy to the cabinet of the PL-707 too. The motor and tone arm are mounted on a solid, non-resonant high-density cabinet. It sits on low-center-of-gravity insulators that effectively shut out shocks, jolts and airborne vibrations applied to the cabinet during play. It does not matter what the frequencies of these external sources of mistracking and muddy reproduction are, for our insulation system is equally effective against them all.

Note: Cartridge is not included in price. Universal type headshell is standard.

Tames resonance for clearer sound

# PL-S70

QUARTZ-PLL FULLY AUTOMATIC TURNTABLE



- **Dynamic Resonance Absorber:** A complex resonator fitted on the arm eliminates resonance-induced vibration, adding clarity to sound.
- **Coreless DC direct-drive motor with Stable Hanging Rotor:** Provides smooth rotation and perfect stability.
- **Quartz-PLL servo plus Periphery Integration:** Instantaneous error compensation for rock-steady platter-speed accuracy.
- **Rigid, low-mass straight PG tone arm:** Tames resonance for better tracking.
- **Fully automatic operation:** Including auto record size selection, record detection, repeat, quick play.
- **Up-front controls:** For easy hands-off operation.

Note: Cartridge is not included in price. Universal type headshell is standard.

More automatic operations than you can think of

# PL-S50

QUARTZ-PLL FULLY AUTOMATIC TURNTABLE



- **Dynamic Resonance Absorber:** A complex resonator fitted on the arm eliminates resonance-induced vibration, adding clarity to sound.
- **Coreless DC direct-drive motor with Stable Hanging Rotor:** Provides smooth rotation and perfect stability.
- **Quartz-PLL servo plus Periphery Integration:** Instantaneous error compensation for rock-steady platter-speed accuracy.
- **Rigid, low-mass straight PG tone arm:** Tames resonance for better tracking.
- **Fully automatic operation:** Including auto record size selection, record detection, quick play.
- **Up-front controls:** For easy hands-off operation.

Note: Cartridge is not included in price. Universal type headshell is standard.

Auto-return convenience and Quartz-PLL accuracy

# PL-S40

QUARTZ-PLL AUTO-RETURN TURNTABLE



- **Dynamic Resonance Absorber:** A complex resonator fitted on the arm eliminates resonance-induced vibration, adding clarity to sound.
- **Coreless DC direct-drive motor with Stable Hanging Rotor:** Provides smooth rotation and perfect stability.
- **Quartz-PLL servo plus Periphery Integration:** Instantaneous error compensation for rock-steady platter-speed accuracy.
- **Rigid, low-mass straight PG tone arm:** Tames resonance for better tracking.
- **Auto-return convenience:** Controls, including cueing, are up front for easy access.

Note: Cartridge is not included in price. Universal type headshell is standard.

The belt-drive turntable redefined

# PL-S30

AUTO-RETURN BELT-DRIVE TURNTABLE



- **Dynamic Resonance Absorber:** A complex resonator fitted on the arm eliminates resonance-induced vibration, adding clarity to sound.
- **DC-servo belt-drive motor with Stable Hanging Rotor:** For speed accuracy and platter stability.
- **Rigid, low-mass straight PG tone arm:** Tames resonance for better tracking.
- **Auto-return convenience:** Controls, including cueing, are up front for easy access. After play, the arm automatically returns to rest.

Note: Cartridge is not included in price. Universal type headshell is standard.

The turntable that will turn a lot of heads

## PL-450 AUTO-RETURN BELT-DRIVE TURNTABLE



- **Mass-concentrated low-mass straight tone arm:** Highly sensitive, non-resonating design for better tracking and better sound.
- **DC-servo belt-drive motor with Stable Hanging Rotor:** Belt-drive system prevents the transmission of motor vibration, Stable Hanging Rotor improves stability.
- **Auto-return convenience:** Arm automatically returns to rest after play, and motor stops.
- **Up-front controls:** Controls, including cueing, are up front for easy access.
- **Plug-in cartridge connector:** Cartridges can be replaced in seconds; solid connections are automatically made.

The second-generation tangential tracking turntable with fully automatic convenience

## PL-L800S TANGENTIAL TRACKING TURNTABLE



- **Tangential tracking:** For reduced tracking error, which means better defined sound with lower distortion.
- **Non-contact linear motor for arm movement:** For high signal-to-noise ratio and smooth arm tracking.
- **Rigid, short low-mass straight PG tone arm:** Tames resonance for better tracking.
- **Coreless DC direct-drive motor with Stable Hanging Rotor:** Provides smooth rotation and perfect stability.
- **Quartz-PLL servo plus Periphery Integration:** Instantaneous error compensation for rock-steady platter-speed accuracy with any load.
- **Computer controlled fully automatic operation:** Fully protects arm and motor from improper operation.
- **Universal cartridge connector:** Any standard cartridge of your choice can be used.
- **High-output moving-coil cartridge (PC-6MC):** Musical clarity, excellent transient response, user replaceable stylus. Connects directly to amp's MM phono terminals.

A microcomputer controlled turntable  
with hands-off direct access to any song on a record

## PL-88FS PROGRAMMABLE, FRONT-LOADING TURNTABLE



● **Front-loading design and stackable:** Constructed to support up to an 88-pound load on top.

● **Computer programmed automatic conveniences:**

*Programmable Play* — Play back a total of 8 songs, or 14 if some are repeated, in any order.

*Index Scan* — The first ten seconds or so of every song may be played, one right after the other.

*Skip Play* — Jump right to the next song.

*Repeat Play* — Repeat any song or songs you've chosen.

● **Double Eye and Address Sensors:** For accurate random access cueing, and speedy automatic operations.

● **Coreless DC direct-drive motor with Stable Hanging Rotor:** Provides smooth rotation and perfect stability.

● **Quartz-PLL servo plus Periphery Integration:** For rock-steady platter-speed accuracy.

● **High-output moving-coil cartridge (PC-41MC):** Directly connects to amp's MM phono terminals.

The front-loading turntable that thinks  
it's a cassette deck

## PL-44FS FRONT-LOADING TURNTABLE



● **Front-loading design and stackable:** Constructed to support up to an 88-pound load on top.

● **Repeat Play:** Lets you hear the same side of a record over and over.

● **Fully automatic operation:** Featured are automatic record size selection, record presence monitor and automatic end-of-play return.

● **DC-servo belt-drive motor with Stable Hanging Rotor:** For excellent speed accuracy and platter stability.

● **High-output moving-coil cartridge (PC-5MC):** User replaceable stylus, directly connects to amp's MM phono terminals.

# Pioneer Speaker Systems

## The Technology

Over the years we have introduced many significant speaker refinements in our quest for absolute realism. Two important achievements are highlighted in this year's speaker system lineup: Polymer Graphite (PG) in the woofers and midranges, and ribbon diaphragms in the tweeters. Both were developed to take advantage of new digital music sources like PCM and Compact Discs.

### Pioneer Polymer Graphite cones — for exciting realism and wide dynamic range.

A speaker cone should respond to the input signal accurately for faithful music reproduction. In practice, however, this is easier said than done. Cones, in particular paper cones, are prone to breakup, a phenomenon that occurs when a section of the cone starts vibrating independently at little provocation, thus generating distortion. Cone breakup can be reduced by constructing the cone out of an inflexible material like metal. But metal cones tend to resonate, or keep ringing even after the signal has been removed. This adds coloration to the sound. In other words, a paper speaker cone would be ideal if it had the stiffness of a metal cone. And a metal cone would be ideal if it had the "internal loss" of a paper cone in order to damp resonance.

Pioneer has developed a cone material that possesses the best properties of both metal and paper cones. It's called Polymer Graphite (or "PG" for short). It's stiff yet has excellent damping qualities. It generates significantly less distortion than either

material. And it has very high power linearity as well as excellent transient response.

What this all means is that any wide-dynamic-range source — be it the new Compact Disc format, or digitally mastered or direct-to-disc recordings — will be heard with a new sense of tightness down to the lowest frequencies, whatever the input level.

### Pioneer ribbon tweeters — direct driven diaphragms for new airiness and accuracy

In new Pioneer ribbon tweeters, we have eliminated voice coils entirely; the entire diaphragm is the voice coil, radiating sound directly. This reduces weight for better transient response, allowing the entire surface to respond more uniformly. Additionally, the ribbon is fixed at two edges, not at all four. The ribbon surface can thus respond with better piston-like motion. Therefore it suffers little breakup even at high input levels. Overall, Pioneer's new ribbon tweeters, whether of beryllium or aluminum, provide wider frequency range, better transient response, higher power linearity, and lower distortion. They have the ability to reproduce

far wider dynamic range than any competing tweeter designs.

### Mirror-image pairs — for better definition

To give you better definition, our speaker systems are specifically designed for left-channel or right-channel use, with the midranges and tweeters arranged in mirror-image fashion.

### High maximum power capability to let you enjoy the full dynamics of your music

New digital sources like Compact Discs and PCM encoded tapes provide a dynamic range of as much as 90dB. To play such sources, speaker systems must have a high maximum power handling capacity. Pioneer speaker systems can handle massive amounts of input power — from the 240 watts of the S-1010 to the 120 watts of the S-510. To do so, they use large, heavy magnets and heavy-duty voice coils in all drivers. Cabinets are heavily constructed to prevent unwanted resonance.

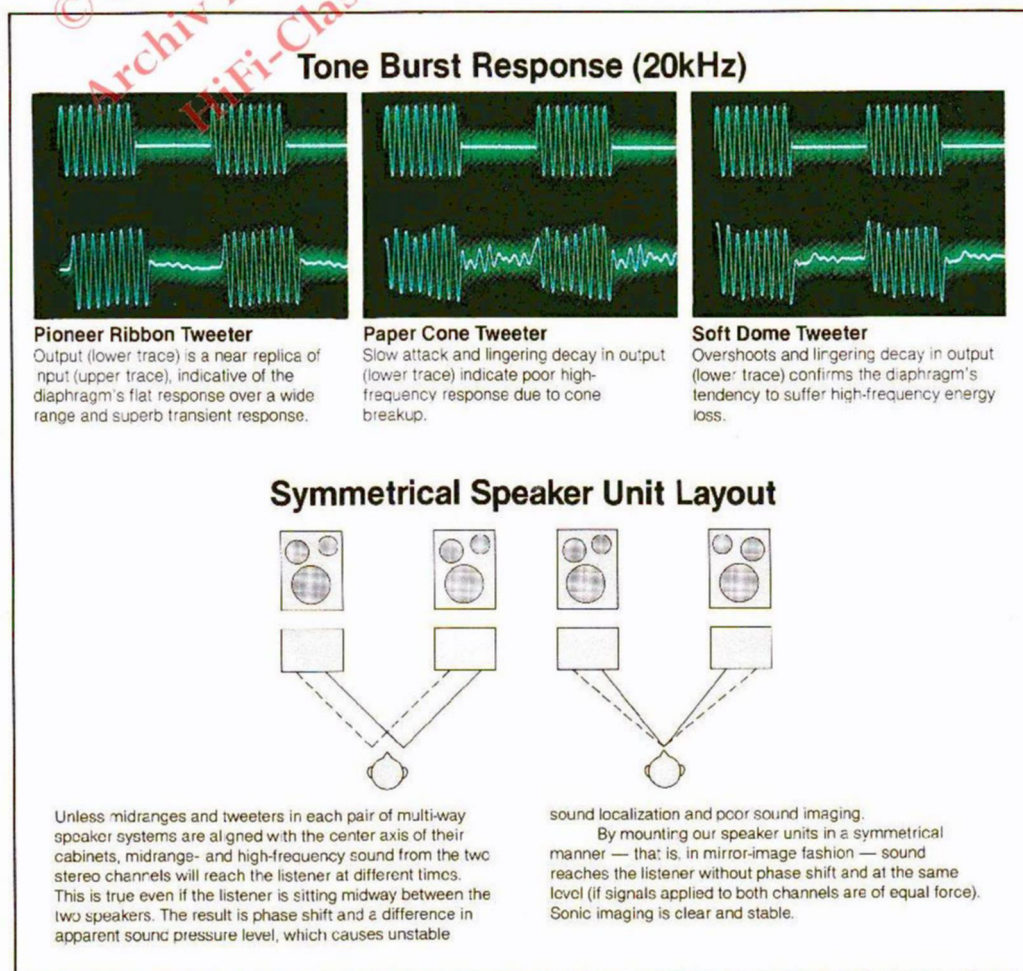
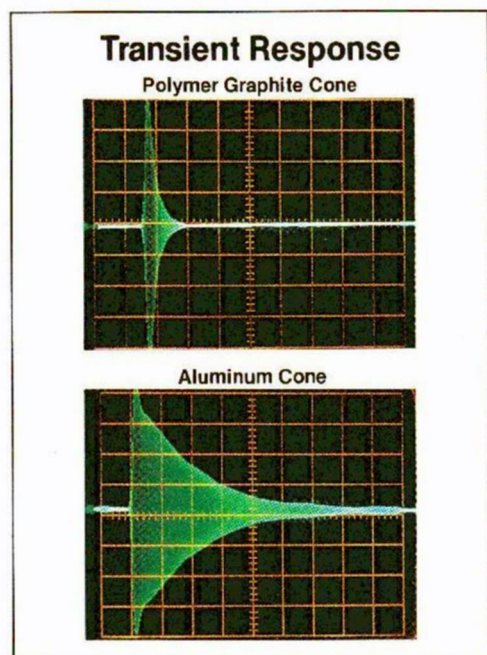

For the you-are-there realism of a live performance

## S-1010

FLOOR-STANDING SPEAKER SYSTEM WITH 14-3/16-INCH PASSIVE RADIATOR



● **Pioneer's newly-developed PG cone diaphragms:**

*10-1/4-inch (26cm) PG cone woofer* provides rich bass with fast transient response, and flat, smooth output over a wide power range.

*2-1/2-inch (6.6cm) PG midrange* for natural presence. Low distortion and superb transient response are combined.

● **Pioneer's beryllium ribbon tweeter:** For better transient response and low distortion thanks to direct sound radiation.

● **14-3/16-inch (36cm) passive radiator:** For crisp, low distortion bass reproduction.

● **Symmetrical speaker arrangement ("mirror image"):** For better definition.

● **Level controls for mids and highs:** Let you match speaker response with the acoustics of your room.

● **Attractive real walnut veneer finish.**

● **Wide frequency response, 28Hz to 50,000Hz;** high power capability, 240 watts maximum.



Walnut veneer cabinet with particleboard for rear panel.

A formidable combination of high power and excellent definition

## S-910

BOOKSHELF SPEAKER SYSTEM WITH 12-INCH WOOFER



● **Pioneer's newly-developed PG cone diaphragms:**

*12-inch (30cm) PG cone woofer* provides rich bass with fast transient response, and flat, smooth output over a wide power range.

*4-inch (10cm) PG midrange* for natural presence. Low distortion and superb transient response are combined.

● **Pioneer's beryllium ribbon tweeter:** For better transient response and low distortion thanks to direct sound radiation.

● **Symmetrical speaker arrangement ("mirror image"):** For better definition.

● **Level controls for mids and highs:** Let you match speaker response with the acoustics of your room.

● **Walnut vinyl finish.**

● **Wide frequency response, 30Hz to 50,000Hz;** high power capability, 240 watts maximum.



Vinyl-covered cabinet is finished in simulated walnut grain, with particleboard for rear panel.

Tailored for the digital age

## S-710 BOOKSHELF SPEAKER SYSTEM WITH 12-INCH WOOFER



- **Pioneer's newly-developed PG cone diaphragms:**

*12-inch (30cm) PG cone woofer* provides rich bass with fast transient response, and flat, smooth output over a wide power range.

*4-inch (10cm) PG midrange* for natural presence. Low distortion and superb transient response are combined.

- **Pioneer's aluminum ribbon tweeter:** For better transient response and low distortion thanks to direct sound radiation.

- **Symmetrical speaker arrangement ("mirror image"):** For better definition.

- **Level control for highs:** Lets you match speaker response with the acoustics of your room.

- **Walnut vinyl finish.**

- **Wide frequency response, 33Hz to 50,000Hz;** high power capability, 180 watts maximum.



Vinyl-covered cabinet is finished in simulated walnut grain, with particleboard for rear panel.

An affordable PG cone speaker system

## S-510 BOOKSHELF SPEAKER SYSTEM WITH 10-INCH WOOFER



- **Pioneer's newly-developed PG cone diaphragms:**

*10-inch (25cm) PG cone woofer* provides rich bass with fast transient response, and flat, smooth output over a wide power range.

*1-3/4-inch (4.5cm) PG midrange* for natural presence. Low distortion and superb transient response are combined.

- **Pioneer's aluminum ribbon tweeter:** For better transient response and low distortion thanks to direct sound radiation.

- **Symmetrical speaker arrangement ("mirror image"):** For better definition.

- **Level control for highs:** Lets you match speaker response with the acoustics of your room.

- **Walnut vinyl finish.**

- **Wide frequency response, 35Hz to 50,000Hz;** high power capability, 120 watts maximum.



Vinyl-covered cabinet is finished in simulated walnut grain, with particleboard for rear panel.

TURBO PLUS with EBD for smooth, extended bass

# CS-705

BOOKSHELF SPEAKER SYSTEM WITH 15-3/4-INCH WOOFER



- **Extra-large 15-3/4-inch (40cm) woofer with EBD (Electronic Bass Drive):** For smooth lows extending to 20Hz.
- **4-3/4-inch (12cm) cone midrange:** For excellent presence.
- **Horn tweeter:** Equipped with an acoustic lens for well-dispersed highs with excellent definition.
- **Ribbon supertweeter:** Extends response to and beyond the limits of human hearing to ensure utmost realism.
- **Three tone selectors:** Choose the position that's best for each type of music.
- **LED power indicators:** Four green LEDs show input level, red LED warns of overload.
- **Wide frequency response:** From 20Hz to 40,000Hz; high power capability, 200 watts maximum music power.

Vinyl-covered cabinet is finished in simulated walnut grain, with particleboard for rear panel.

For real bass that you can feel — TURBO PLUS

# CS-605

BOOKSHELF SPEAKER SYSTEM WITH 12-INCH WOOFER



- **Large 12-inch (30cm) woofer with EBD (Electronic Bass Drive):** For smooth lows extending to 25Hz.
- **4-3/4-inch (12cm) cone midrange:** For excellent presence.
- **Horn tweeter:** Equipped with an acoustic lens for well-dispersed highs with excellent definition.
- **Ribbon supertweeter:** Extends response to and beyond the limits of human hearing to ensure utmost realism.
- **Three tone selectors:** Choose the position that's best for each type of music.
- **LED power indicators:** Green LED indicates safe operation, red LED indicates overload.
- **Wide frequency response:** From 25Hz to 40,000Hz; high power capability, 150 watts maximum music power.

Vinyl-covered cabinet is finished in simulated walnut grain, with particleboard for rear panel.

Compact size, full-size sound

# CS-405

BOOKSHELF SPEAKER SYSTEM WITH 10-INCH WOOFER



- **High-power 12-inch (30cm) woofer:** High efficiency magnetic circuit and high-temperature voice coil for high power capacity and full bass.
- **4-inch (10cm) cone midrange:** Use of heat-resistant voice coil and lightweight cone mean crisp, clean mids.
- **Ribbon tweeter:** Extended response, low distortion, crisp, delicate highs.
- **Wide frequency response:** From 40Hz to 40,000Hz; high power capability, 120 watts maximum music power.

Vinyl-covered cabinet is finished in simulated walnut grain, with particleboard for rear panel.

A compact system featuring double normal bass output thanks to Pioneer EBD

# S-T5

BOOKSHELF SPEAKER SYSTEM — "TURBO PRO"



- **EBD (Electronic Bass Drive) System:** For extended bass response and wide dynamic range.
- **Compact size:** 7-3/16 inches (18.2cm) wide and deep, 10-1/8 inches (25.7cm) high.
- **6-1/2-inch (16cm) woofer:** A rigid and light PG cone provides crisp and transient lows.
- **1-inch (2.5cm) soft-dome tweeter:** For brilliant highs.
- **Solid enclosure:** Resonance-resistant design uses thick, heavy materials.
- **Frequency response, 45Hz to 20,000Hz;** power capability, 90 watts maximum.

# Add-on Components



## MA-100 MULTI-MIXING AMPLIFIER

**The great mixing machine — 6 inputs, parametric equalization and electronic echo**

- **6 inputs for mixing:** The MA-100 accepts and mixes one tape, one source and four additional inputs — a grand total of six inputs. The last four may be any combination of electric instruments (guitars, etc.) and mikes.
- **Panpots for the additional inputs (ch. 1 through 4):** Let you move and fix the sonic image anywhere within the stereo sound field.
- **Echo, chorus and duet:** To each of the six individual inputs, the MA-100 can apply one special effect in addition to echo. Chorus adds a backup group to a solo act; duet turns a solo into a duet.
- **BBD (Bucket Brigade Device) electronic echo:** For natural, low-distortion application of echo. Adjustable over a 3-second range.
- **Parametric equalizer for two inputs (ch. 3 and 4):** Select two frequencies — any low frequency between 100Hz and 900Hz, and any high frequency between 1kHz and 13kHz. Gain for each selected frequency is variable over a  $\pm 10$ dB range.

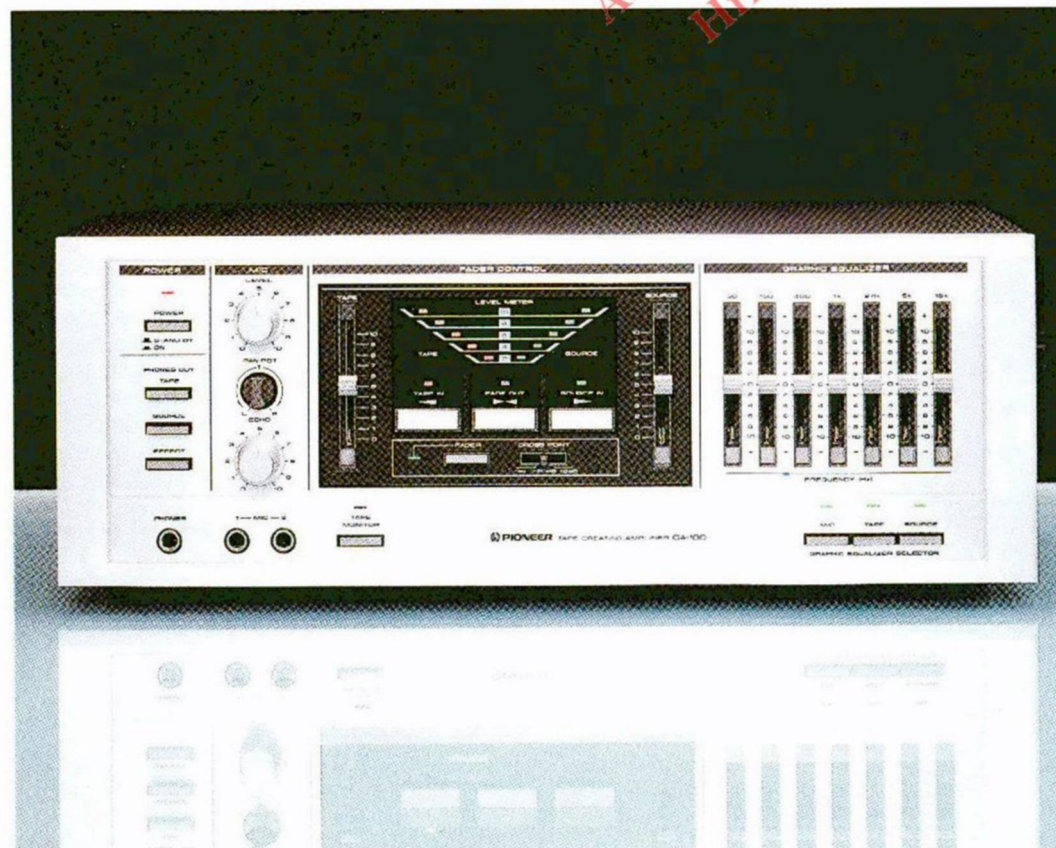

## CA-100 TAPE CREATING AMPLIFIER

**For everyone serious about taping — auto fader, 7-band graphic equalizer, mike mixing, more**

- **Automatic fader:** Easily and smoothly cross two program sources, fading one (tape) in while fading the other (tuner or turntable) out.
- **Cross Point selector:** At the infinity position, only after one source has completely faded out does the other fade in. At  $-20$ dB and  $-6$ dB positions, fade-ins and -outs overlap, more so at the  $-6$ dB position.
- **7-band graphic equalizer:** Lets you equalize tape, phono, tuner or mike sound to create your own personal sound. Adjustable frequency range is from 60Hz to 15kHz.
- **BBD electronic echo:** Apply echo to the two mike inputs; duration is adjustable up to a full two seconds. BBD means more natural application of echo with lower distortion.
- **Panpot for microphone:** Lets you position mike sound anywhere between your speakers, or move the sound from one point to another.
- **LED level meters:** Double as fader indicators.

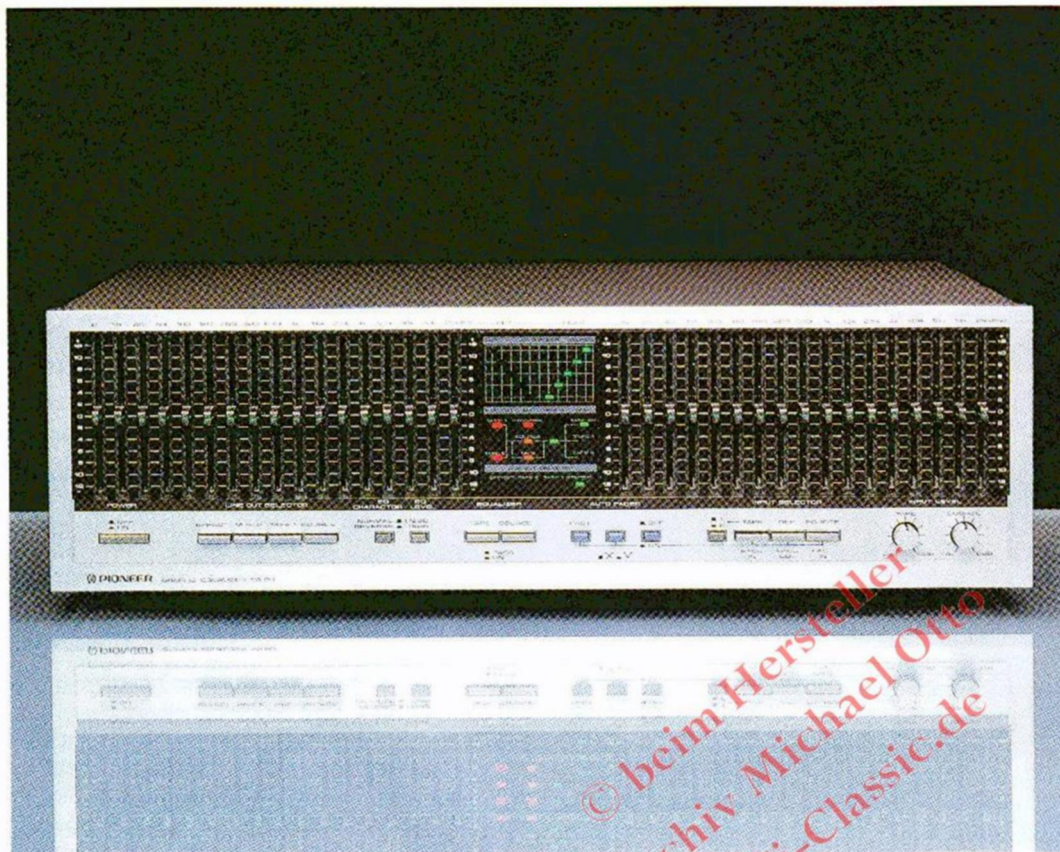

## SG-90

17-BAND GRAPHIC EQUALIZER

**Designed for top equalizing accuracy and versatility**

- **2/3-octave 17-band equalizer for true versatility:** Provided are 17 controls per channel, covering a range from 16Hz to 25kHz.
- **Low distortion** (0.001%, from 20 to 20,000Hz, all controls at flat), and a high signal-to-noise ratio (120dB).
- **Auto fader:** Helps you create your own tapes with professional fade-ins and fade-outs between songs.
- **Adjustable control level:**  $\pm 12$ dB for normal use,  $\pm 6$ dB for delicate critical adjustments.
- **EQ switches:** Let you equalize a program source while recording unequalized. "Reverse response" lets you perform tape noise reduction automatically.
- **2-deck connection:** Lets you apply equalization as you dub tapes.

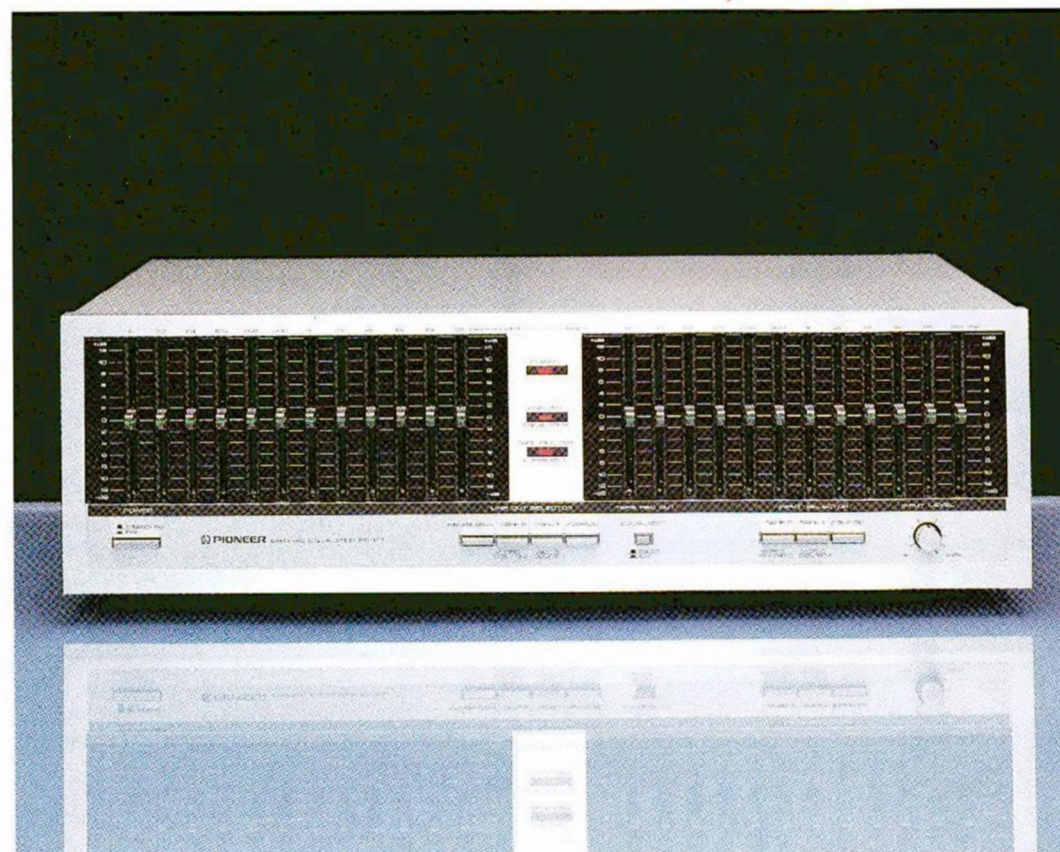

## SG-60

12-BAND GRAPHIC EQUALIZER

**Achieve flat response in any listening room**

- **One-octave equalizer:** 12 controls per channel, from 16Hz to 32kHz, give you complete tonal versatility. Levels may be adjusted up to  $\pm 12$ dB, with indents every 2dB.
- **Equalizer recording:** Equalized sound may be recorded on a connected tape deck. In this way, scratch and hiss noise can be eliminated as you dub records and tapes.
- **Input attenuator control:** Continuously adjusts input level from full to complete mute. Doubles as fader.
- **2 tape monitor connections:** Let you hear two tape decks and dub between the two.
- **LED indicators:** Show power, EQ defeat and record-out program.
- **Low-noise, low-distortion circuitry.**



## SG-50(M)

10-BAND GRAPHIC EQUALIZER/SPECTRUM ANALYZER

**Equalizer, spectrum analyzer and everything else necessary to achieve perfectly flat response**

- **One-octave equalizer:** 10 controls adjust both channels simultaneously, with frequency range from 32Hz to 16kHz.
- **Built-in 10-band spectrum analyzer:** Bands matched with equalizer controls. Permits precise monitoring of frequency makeup of sound. Level control and on/off switch provided.
- **Pink noise generator and calibrated microphone (supplied):** Allow you to easily compensate for the acoustics of your room, to attain optimally flat response.

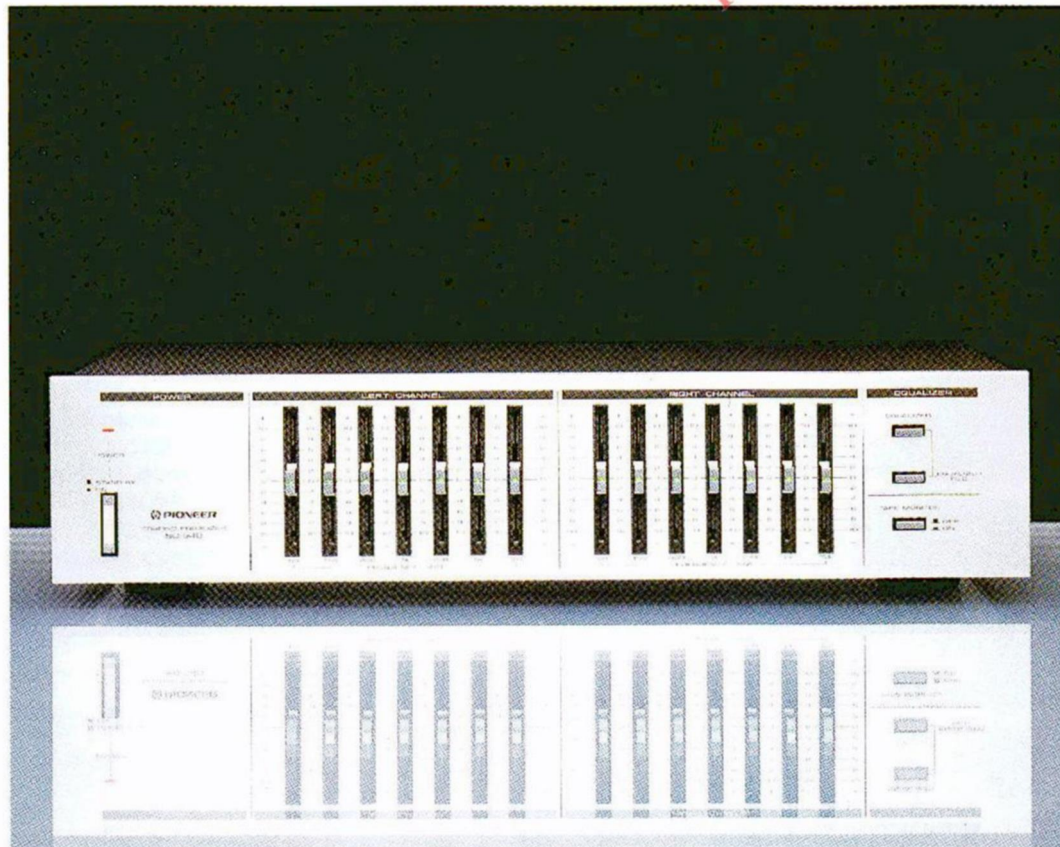

## SG-540

7-BAND GRAPHIC EQUALIZER

**An easy to use equalizer that matches any system**

- **7 equalizer controls per channel:** Versatile enough to compensate for room acoustics, speaker response, etc.
- **LED-lit slide controls:** Graphically show the overall shape of the equalization curve.
- **Equalizer recording:** Equalized sound can be recorded on a connected tape deck. In this way, scratch and hiss noise can be eliminated as you dub records and tapes.
- **Tape monitor switch:** Lets you connect and hear a connected tape deck.
- **Low-noise, low-distortion circuitry.**
- **Low silhouette.**



## SR-60

REVERBERATION AMPLIFIER

### Add life to your music

- **Effect selector:** Three positions are offered.

*REVERB* — Adds echo to reverb components only when there's a fixed sound image at center of stereo spread. Turns your listening room into a concert hall.

*ECHO* — Applies echo to all signals.

*DUET* — Makes a solo singer sound like a duet.

- **Reverb level control:** Continuously adjusts the reverb time over 0 to 3 second range.

● **BBD (Bucket Brigade Device) reverberation amp:** For natural, low-distortion application of reverberation.

● **Time/depth display:** Shows the amount of reverb as a pleasing visual effect.

● **Reverb recording:** Allows you to record music with reverb added.

- **Line output.**



## RG-60

DYNAMIC PROCESSOR

### Enjoy the thrill of a live performance from your records and tapes

● **Dynamic expansion control:** Enables you to expand dynamic range in 3dB steps from 4 to 16dB, to restore the dynamic peaks and valleys of the original performance taken out during mastering and mixdown.

● **Fluorescent level indicator:** Shows the effect of dynamic expansion with precision and responsiveness.

● **Noise reduction:** Loud passages are made louder, soft passages softer. Unlike a "closed" (two-way) noise reduction systems like Dolby NR or dbx\*, the RG-60 is an "open" system with the ability to reduce noise in any program material.

● **Top-notch specifications:** Patch the unit into the adaptor or tape loop of your amp or receiver with confidence — its hi-fi specifications are superb.

\*"dbx" is a trademark of dbx Inc.

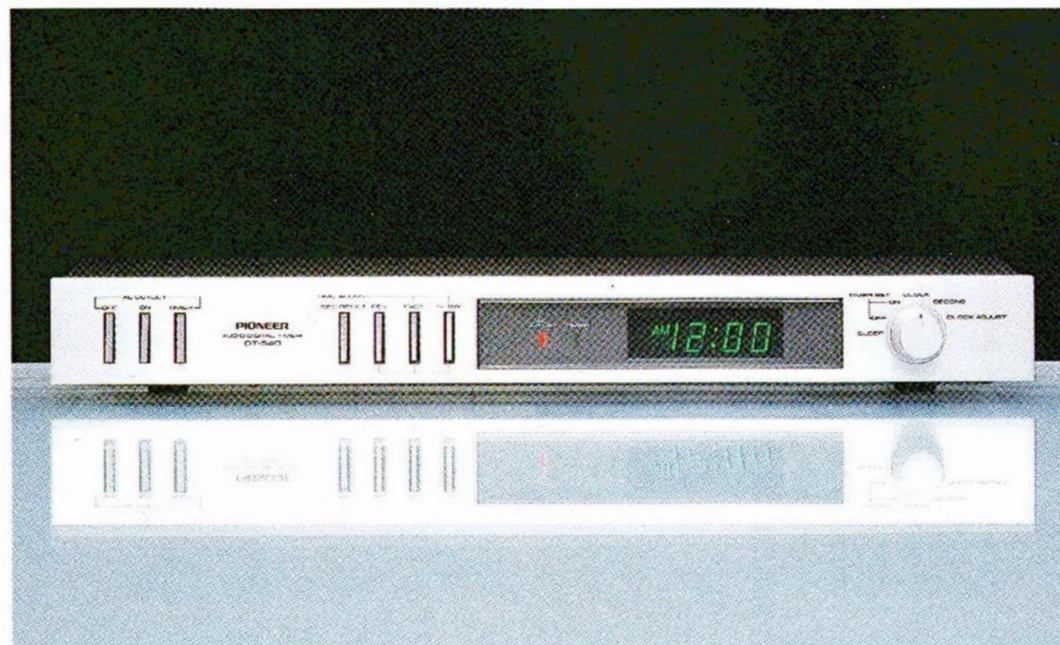

## DT-540

ELECTRONIC DIGITAL TIMER

### For time-shift recording and wakeup calls

● **24-hour cycle design:** Lets you turn your entire hi-fi system (or a deck and tuner alone) on and off once every day.

● **1-minute accuracy:** Turn connected equipment on and off at precisely the right times.

● **Sleep timer:** Turns off connected equipment in any time increment from 1 minute to 1 hour 59 minutes, automatically.

● **Convenient time and adjust controls:**

SECOND RESET sets the time accurately down to the second.

REVERSE lets you backtrack if you inadvertently go beyond the intended setting.

● **Manual AC on/off mode.**

● **Two AC outlets.**

# Specifications

## Receivers

|  | SX-V90  | SX-60  | SX-50  | SX-40   | SX-303   | SX-202   |
|--|---|--|--|---|--|--|
| <b>AMPLIFIER SECTION</b>                                     |   |  |  |   |  |  |
| Continuous Power Output:                                     | <b>Continuous average power output of 125 watts* per channel, min. at 8 ohms from 20 hertz to 20,000 hertz with no more than 0.005% total harmonic distortion</b> | <b>Continuous average power output of 80 watts* per channel, min. at 8 ohms from 20 hertz to 20,000 hertz with no more than 0.005% total harmonic distortion</b> | <b>Continuous average power output of 50 watts* per channel, min. at 8 ohms from 20 hertz to 20,000 hertz with no more than 0.007% total harmonic distortion</b> | <b>Continuous average power output of 38 watts* per channel, min. at 8 ohms from 20 hertz to 20,000 hertz with no more than 0.02% total harmonic distortion</b> | <b>Continuous average power output of 45 watts* per channel, min. at 8 ohms from 40 hertz to 20,000 hertz with no more than 0.3% total harmonic distortion</b> | <b>Continuous average power output of 25 watts* per channel, min. at 8 ohms from 40 hertz to 20,000 hertz with no more than 0.3% total harmonic distortion</b> |
| Total Harmonic Distortion: (8 ohms)                          | 0.005% (20 — 20,000Hz) (continuous rated power output, from Power In)   | 0.005% (20 — 20,000Hz) (continuous rated power output, from Power In)  | 0.007% (20 — 20,000Hz) (continuous rated power output, from Power In)  | 0.02% (20 — 20,000Hz) (continuous rated power output, from AUX)   | 0.3% (40 — 20,000Hz) (continuous rated power output, from Tape)  | 0.3% (40 — 20,000Hz) (continuous rated power output, from Tape)  |
| Intermodulation Distortion: (50Hz : 7,000Hz = 4 : 1, 8 ohms) | 0.005% (continuous rated power output, from Power In)   | 0.005% (continuous rated power output, from Power In)  | 0.007% (continuous rated power output, from Power In)  | 0.02% (continuous rated power output, from AUX)   | 0.3% (continuous rated power output, from Tape)  | 0.3% (continuous rated power output, from Tape)  |
| Input Sensitivity/Impedance                                  |   |  |  |   |  |  |
| PHONO (MM):  | 2.5mV/50k ohms  | 2.5mV/50k ohms   | 2.5mV/50k ohms   | 2.5mV/50k ohms  | 2.5mV/50k ohms   | 2.5mV/50k ohms   |
| PHONO (MC):  | 0.25mV/100 ohms   | 0.25mV/100 ohms  | —  | —   | —  | —  |
| CD/AUX or TAPE PLAY:   | 150mV/50k ohms  | 150mV/50k ohms   | 150mV/50k ohms   | 150mV/50k ohms  | 150mV/50k ohms   | 150mV/50k ohms   |
| VCR, VIDEO DISC:   | 150mV/50k ohms  | —  | —  | —   | —  | —  |
| PHONO Overload Level   |   |  |  |   |  |  |
| PHONO (MM):  | 150mV (1kHz, T.H.D. 0.015%)   | 150mV (1kHz, T.H.D. 0.007%)  | 130mV (1kHz, T.H.D. 0.1%)  | 130mV (1kHz, T.H.D. 0.1%)   | 150mV (1kHz, T.H.D. 0.1%)  | 150mV (1kHz, T.H.D. 0.1%)  |
| PHONO (MC):  | 14mV (1kHz, T.H.D. 0.015%)  | 14mV   | —  | —   | —  | —  |
| Output Level/Impedance                                       |   |  |  |   |  |  |
| TAPE REC:  | 150mV   | 150mV/2.2k ohms  | 150mV/2.2k ohms  | 150mV/2.2k ohms   | 150mV  | 150mV  |
| VCR 1 OUT, VIDEO DISC OUT:                                   | 150mV   | —  | —  | —   | —  | —  |
| SPEAKER:   | A, B, A+B, OFF  | A, B, A+B, OFF   | A, B, A+B, OFF   | A, B, A+B, OFF  | A, B, A+B, OFF   | A, B, A+B, OFF   |
| HEADPHONES:  | Low impedance   | Low impedance  | Low impedance  | Low impedance   | Low impedance  | Low impedance  |
| Frequency Response   |   |  |  |   |  |  |
| PHONO (RIAA Equalization) (REC OUT):                         | 20 — 20,000Hz ± 0.3dB   | 20 — 20,000Hz ± 0.3dB  | 20 — 20,000Hz ± 0.3dB  | 20 — 20,000Hz ± 0.5dB   | 30 — 20,000Hz ± 0.5dB  | 30 — 20,000Hz ± 0.5dB  |
| CD/AUX or TAPE PLAY:   | 5 — 100,000Hz 0dB, — 3dB  | 5 — 100,000Hz 0dB, — 3dB   | 5 — 100,000Hz 0dB, — 3dB   | 5 — 100,000Hz +0.5dB, — 3dB   | 15 — 50,000Hz +1dB, — 3dB  | 15 — 50,000Hz +1dB, — 3dB  |
| Tone Control   |   |  |  |   |  |  |
| BASS:  | ± 6dB (100Hz)   | ± 6dB (100Hz)  | ± 6dB (100Hz)  | ± 6dB (100Hz)   | ± 9dB (100Hz)  | ± 9dB (100Hz)  |
| TREBLE:  | ± 6dB (10kHz)   | ± 6dB (10kHz)  | ± 6dB (10kHz)  | ± 6dB (10kHz)   | ± 9dB (10kHz)  | ± 9dB (10kHz)  |
| Filter   |   |  |  |   |  |  |
| SUBSONIC:  | 20Hz (— 6dB/oct.)   | 20Hz (— 6dB/oct.)  | 20Hz (— 6dB/oct.)  | 20Hz (— 6dB/oct.)   | —  | —  |
| Loudness Contour:  | ON/OFF  | ON/OFF   | ON/OFF   | ON/OFF  | ON/OFF   | ON/OFF   |
| Hum and Noise (IHF, short-circuited A-network)               |   |  |  |   |  |  |
| PHONO MM/MC:   | 86dB/67dB   | 86dB/67dB  | 80dB/—   | 70dB/—  | 71dB/—   | 71dB/—   |
| CD/AUX or TAPE PLAY:   | 100dB   | 95dB   | 95dB   | 95dB  | 97dB   | 97dB   |
| <b>FM TUNER SECTION</b>                                      |   |  |  |   |  |  |
| Usable Sensitivity (Mono):                                   | 10.8dBf (0.95µV, 75 ohms)   | 10.3dBf (0.9µV, 75 ohms)   | 10.8dBf (0.95µV, 75 ohms)  | 10.8dBf (0.95µV, 75 ohms)   | 10.7dBf (0.94µV, 75 ohms)  | 10.7dBf (0.94µV, 75 ohms)  |
| 50dB Quieting Sensitivity                                    |   |  |  |   |  |  |
| Mono:  | 16.2dBf (1.8µV, 75 ohms)  | 15.7dBf (1.6µV, 75 ohms)   | 17.3dBf (2µV, 75 ohms)   | 17.3dBf (2µV, 75 ohms)  | 15.3dBf (1.6µV, 75 ohms)   | 15.3dBf (1.6µV, 75 ohms)   |
| Stereo:  | 37.7dBf (21µV, 75 ohms)   | 37dBf (19.5µV, 75 ohms)  | 37.5dBf (20µV, 75 ohms)  | 37.5dBf (20µV, 75 ohms)   | 37.6dBf (21µV, 75 ohms)  | 37.6dBf (21µV, 75 ohms)  |
| Signal-to-Noise Ratio  |   |  |  |   |  |  |
| Mono:  | 88dB (80dBf)  | 83dB (60dBf)   | 79dB (60dBf)   | 79dB (60dBf)  | 75dB (85dBf)   | 75dB (85dBf)   |
| Stereo:  | 82dB (80dBf)  | 80dB (80dBf)   | 75dB (80dBf)   | 75dB (80dBf)  | 70dB (85dBf)   | 70dB (85dBf)   |
| Distortion (65dBf)   |   |  |  |   |  |  |
| 100Hz (Mono/Stereo):   | 0.04% / 0.08%   | 0.1% / 0.2%  | 0.1% / 0.2%  | 0.1% / 0.2%   | —  | —  |
| 1kHz (Mono/Stereo):  | 0.02% (wide), 0.15% (narrow) / 0.04% (wide), 0.5% (narrow)  | 0.07% / 0.1%   | 0.1% / 0.15%   | 0.1% / 0.15%  | 0.3% / 0.6%  | 0.3% / 0.6%  |
| 6kHz (Mono/Stereo):  | 0.07% / 0.08%   | 0.15% / 0.25%  | 0.25% / 0.4%   | 0.25% / 0.4%  | —  | —  |
| Frequency Response:  | 20 — 15,000Hz 0dB, — 1dB  | 20 — 15,000Hz 0dB, — 1dB   | 20 — 15,000Hz — 0.5dB, — 1dB   | 20 — 15,000Hz +0.5dB, — 1dB   | 30 — 15,000Hz +0.5dB, — 1dB  | 30 — 15,000Hz +0.5dB, — 1dB  |
| Alternate Channel Selectivity:                               | 85cB (400kHz, narrow)   | 80dB (400kHz)  | 65dB (400kHz)  | 65dB (400kHz)   | 50cB (400kHz)  | 50cB (400kHz)  |
| Muting Threshold:  | 29.3dBf (8µV, 75 ohms) (Auto-tuning)  | 29.3dBf (8µV, 75 ohms) (Auto-tuning)   | 29.3dBf (8µV, 75 ohms)   | 29.3dBf (8µV, 75 ohms)  | 27dBf (6.3µV, 75 ohms)   | 27dBf (6.3µV, 75 ohms)   |
| Stereo Separation  |   |  |  |   |  |  |
| 1kHz:  | 60dB (wide)   | 50dB   | 45dB   | 45dB  | 35dB   | 35dB   |
| 30 — 15,000Hz:   | 45cB (wide)   | 35dB   | 35dB   | 35dB  | —  | —  |
| Antenna Input:   | 300 ohms balanced / 75 ohms unbalanced  | 300 ohms balanced / 75 ohms unbalanced   | 300 ohms balanced / 75 ohms unbalanced   | 300 ohms balanced / 75 ohms unbalanced  | 300 ohms balanced / 75 ohms unbalanced   | 300 ohms balanced / 75 ohms unbalanced   |
| <b>AM TUNER SECTION</b>                                      |   |  |  |   |  |  |
| Sensitivity  |   |  |  |   |  |  |
| (IHF Loop Antenna):  | 220µV/m   | 220µV/m  | 220µV/m  | 220µV/m   | 320µV/m  | 320µV/m  |
| (IHF, External Antenna):                                     | 10µV  | 10µV   | 10µV   | 10µV  | 30µV   | 30µV   |
| Selectivity:   | 60dB  | 60dB   | 60dB   | 60dB  | 25dB   | 25dB   |
| Signal-to-Noise Ratio:                                       | 50dB  | 50dB   | 50dB   | 50dB  | 43dB   | 43dB   |
| Antenna:   | High Sensitivity Loop Antenna   | High Sensitivity Loop Antenna  | High Sensitivity Loop Antenna  | High Sensitivity Loop Antenna   | Loop Antenna   | Loop Antenna   |
| <b>VIDEO SECTION</b>   |   |  |  |   |  |  |
| Input (Sensitivity/Impedance)                                |   |  |  |   |  |  |
| VCR 1, VCR 2, Video Disc Player:                             | 1Vp-p/75 ohms unbalanced  | —  | —  | —   | —  | —  |
| Output (Level/Impedance)                                     |   |  |  |   |  |  |
| VCR 1, Video Disc Player, Monitor TV:                        | 1Vp-p/75 ohms unbalanced  | —  | —  | —   | —  | —  |
| RF (V-F) Input, Output:                                      | 75 ohms unbalanced  | —  | —  | —   | —  | —  |
| <b>MISCELLANEOUS</b>   |   |  |  |   |  |  |
| Power Requirement:   | 120V 60Hz   | 120V 60Hz  | 120V 60Hz  | 120V 60Hz   | 120V 60Hz  | 120V 60Hz  |
| Power Consumption:   | 360W  | 310W   | 240W   | 195W  | 190W   | 125W   |
| Dimensions (W x H x D): (without package)                    | 16-9/16 x 5-15/16 x 17-3/16 inches / 420 x 150 x 436 mm   | 16-9/16 x 5-1/8 x 14-5/16 inches / 420 x 130 x 364 mm  | 16-9/16 x 4-3/4 x 12-1/4 inches / 420 x 120 x 311 mm   | 16-9/16 x 4-3/4 x 12-1/4 inches / 420 x 120 x 311 mm  | 16-9/16 x 3-7/8 x 8-7/16 inches / 420 x 98 x 214 mm  | 16-9/16 x 3-7/8 x 8-7/16 inches / 420 x 98 x 214 mm  |
| Weight (without package):                                    | 33 lbs. 1 oz./15kg  | 22 lbs. 11 oz./10.3kg  | 15 lbs. 14 oz./7.2kg   | 14 lbs. 5 oz./6.5kg   | 11 lbs./5kg  | 9 lbs. 8 oz./4.3kg   |

\*Measured pursuant to the Federal Trade Commission's Trade Regulation Rule on Power Output Claims for Amplifiers

NOTE: Specifications and design subject to modification without notice.

# Compact Disc Player

| P-D70  |   |
|--|---|
| <b>General</b>                               |   |
| System:                                      | Compact Disc Digital Audio System                           |
| <b>Disc</b>                                  |   |
| Diameter:                                    | 120mm   |
| Thickness:                                   | 1.2mm   |
| Playing time:                                | over 60 minutes (stereo)                                    |
| Scanning velocity:                           | 1.2 — 1.4m/sec  |
| Rotation:                                    | Counterclockwise (as viewed from playing side)              |
| <b>Signal format</b>                         |   |
| Sampling frequency:                          | 44.1kHz   |
| Quantization:                                | 16 bits linear/channel                                      |
| Transfer bit rate:                           | 4.3218M bits/sec  |
| Modulation system:                           | EFM   |
| Error correction:                            | CIRC system   |
| Pre-emphasis:                                | 50/15µsec (automatic switching)                             |
| Pickup laser:                                | Semiconductor laser, wavelength, 0.78µm                     |
| <b>Audio Section</b>                         |   |
| Frequency response:                          | 5Hz — 20kHz ± 0.5dB   |
| Signal-to-noise ratio:                       | more than 95dB (1kHz)                                       |
| Dynamic range:                               | more than 95dB (1kHz)                                       |
| Channel separation:                          | more than 90dB (1kHz)                                       |
| Wow and flutter:                             | unmeasurable (dependent on precision of crystal oscillator) |
| Distortion:                                  | less than 0.004% (1kHz, 0dB)                                |
| Output voltage:                              | 200mV (1kHz, -20dB)   |
| Headphone output:                            | 36mW (32 ohms)  |
| Number of channels:                          | 2 (stereo)  |
| <b>Functions</b>                             |   |
| ● Play ● Pause ● Slow Scan ● Track Search    |   |
| ● Minute/Index Search ● Memory Stop ● Memory |   |
| (A — B) Repeat ● Track Repeat ● All Repeat   |   |
| ● Programmed Playback ● Programmed Repeat    |   |
| <b>Miscellaneous</b>                         |   |
| Power requirement:                           | 120V 60Hz   |
| Power consumption:                           | 38W   |
| Dimensions:                                  | 16-9/16 (W) x 3-7/8 (H) x 11-3/16 (D) inches                |
| (without package)                            | 420 (W) x 98 (H) x 300 (D) mm                               |
| Weight                                       | 16 lbs. 9 oz./7.5kg   |
| (without package)                            |   |

# Amplifiers

|   | A-90  | A-70  | A-60  |
|---|---|---|---|
| <b>AMPLIFIER SECTION</b>  |   |   |   |
| Continuous Power Output:  | <b>Continuous average power output of 200 watts* per channel, min. at 8 ohms from 20 hertz to 20,000 hertz with no more than 0.002% total harmonic distortion</b> | <b>Continuous average power output of 120 watts* per channel, min. at 8 ohms from 20 hertz to 20,000 hertz with no more than 0.003% total harmonic distortion</b> | <b>Continuous average power output of 100 watts* per channel, min. at 8 ohms from 20 hertz to 20,000 hertz with no more than 0.007% total harmonic distortion</b> |
| Total Harmonic Distortion: (20 — 20,000Hz, 8 ohms)                | 0.002% (continuous rated power output)  | 0.003% (continuous rated power output)  | 0.007% (continuous rated power output)  |
| Intermodulation Distortion: (50Hz/7,000Hz = 4:1, 8 ohms from AUX) | 0.002% (continuous rated power output)  | 0.003% (continuous rated power output)  |   |
| Damping Factor: (20 — 20,000Hz, 8 ohms)                           | 100   | 60  | 60  |
| Input Sensitivity/Impedance                                       |   |   |   |
| PHONO (MM):   | 2.5mV/50k ohms  | 2.5mV/50k ohms  | 2.5mV/50k ohms  |
| PHONO (MC):   | 0.15mV/100 or 33 ohms   | 0.2mV/100 ohms  | 0.2mV/100 ohms  |
| TUNER, AUX, TAPE  | 150mV/50k ohms  | 150mV/50k ohms  | 150mV/50k ohms  |
| PHONO Overload Level (1kHz) MM/MC:                                | 300mV/18mV (T.H.D. 0.0008%)   | 150mV/11mV (T.H.D. 0.005%)  | 200mV/17mV (T.H.D. 0.005%)  |
| Output Level/Impedance  |   |   |   |
| TAPE REC:   | 150mV/2.2k ohms   | 150mV/2.2k ohms   | 150mV/2.2k ohms   |
| SPEAKER:  | A, B, A+B, OFF  | A, B, A+B, OFF  | A, B, A+B, OFF  |
| HEADPHONES:   | Low impedance   | Low impedance   | Low impedance   |
| Frequency Response  |   |   |   |
| PHONO (RIAA Equalization):  | 20 — 100,000Hz ± 0.2dB  | 20 — 20,000Hz ± 0.2dB   | 20 — 20,000Hz ± 0.2dB   |
| TUNER, AUX, TAPE PLAY:  | 5 — 100,000Hz 0dB, -3dB   | 5 — 100,000Hz 0dB, -3dB   | 5 — 100,000Hz 0dB, -3dB   |
| Tone Control  |   |   |   |
| BASS:   | ± 6dB (100Hz) at 200Hz position<br>Turnover Frequency: 100Hz/200Hz/400Hz  | ± 10dB (100Hz)  | ± 10dB (100Hz)  |
| TREBLE:   | ± 6dB (10kHz) at 4kHz position<br>Turnover Frequency: 2kHz/4kHz/8kHz  | ± 10dB (10kHz)  | ± 10dB (10kHz)  |
| Filter (SUBSONIC):  | 15Hz (-6dB/oct.)  | 15Hz (-6dB/oct.)  | 15Hz (-6dB/oct.)  |
| Loudness Contour: (Volume at -40dB position)                      | —   | +6dB (100Hz), +3dB (10kHz)  | +6dB (100Hz), +3dB (10kHz)  |
| Hum and Noise (HF, A-network)                                     |   |   |   |
| PHONO MM/MC:  | 89dB/174dB  | 87dB/70dB   | 86dB/70dB   |
| TUNER, AUX, TAPE PLAY:  | 113dB   | 108dB   | 105dB   |
| <b>MISCELLANEOUS</b>  |   |   |   |
| Power Requirement:  | 120V 60Hz   | 120V 60Hz   | 120V 60Hz   |
| Power Consumption:  | 350W  | 240W  | 170W  |
| Dimensions (W x H x D) (without package)                          | 16-9/16 x 3-7/8 x 16-9/16 inches<br>420 x 150 x 420 mm  | 16-9/16 x 5-3/16 x 16-3/16 inches<br>420 x 131 x 411 mm   | 16-9/16 x 5-1/8 x 13-1/16 inches<br>420 x 130 x 331 mm  |
| Weight (without package):   | 43 lbs. 3 oz./19.6kg  | 27 lbs. 2 oz./12.3kg  | 20 lbs. 12 oz./9.4kg  |

\*Measured pursuant to the Federal Trade Commission's Trade Regulation Rule on Power Output Claims for Amplifiers.

# Cassette Tape Decks

|   | CT-A9   | CT-A7  | CT-90R   | CT-70R   | CT-50R   |
|---|---|--|--|--|--|
| Type:                                     | 4-track, 2-channel recording and playback stereo cassette tape deck                       | 4-track, 2-channel recording and playback stereo cassette tape deck                    | 4-track, 2-channel auto-reverse recording and playback stereo cassette tape deck                                   | 4-track, 2-channel auto-reverse recording and playback stereo cassette tape deck                                   | 4-track, 2-channel auto-reverse recording and playback stereo cassette tape deck |
| Motors:                                   | Quartz-PLL direct-drive motor for capstan drive x 1, Coreless DC motor for reel drive x 1 | DC-servo motor for capstan drive x 1, DC motor for reel drive x 1                      | Direct drive, brushless DC servo Hall-motor for capstan, Direct-drive brushless DC-servo Hall-motors for each reel | Direct-drive, brushless DC-servo Hall-motor for capstan, Direct drive brushless DC-servo Hall-motors for each reel | DC-servo motor for capstan drive x 1, DC motor for reel drive x 1                |
| Heads:                                    | "Ribbon Sendust" recording & playback combination head, Special alloy erasing head x 1    | "Ribbon Sendust" recording & playback combination head, Special alloy erasing head x 1 | "Ribbon Sendust" recording & playback combination head (swivel), ALPERM (special alloy) erasing head x 2           | "Ribbon Sendust" recording/playback head (swivel) x 1, ALPERM (special alloy) erasing head x 2                     | "Hard Permalloy" recording/playback head x 1, Ferrite erasing head x 1 (swivel)  |
| Fast Winding Time (C-60 tape):            | 80 seconds  | 80 seconds   | 90 seconds   | 90 seconds   | 90 seconds   |
| Wow and Flutter (WRMS):                   | 0.018%  | 0.028%   | 0.03%  | 0.03%  | 0.038%   |
| Frequency Response                        |   |  |  |  |  |
| Normal tape (-20dB):                      | 20 — 21,000Hz (30 — 19,000Hz ± 3dB)   | 20 — 20,000Hz (30 — 19,000Hz ± 3dB)  | 20 — 19,000Hz (20 — 18,000Hz ± 3dB)  | 25 — 17,000Hz (30 — 16,000Hz ± 3dB)  | 25 — 17,000Hz (30 — 16,000Hz ± 3dB)  |
| Chrome tape (-20dB):                      | 20 — 22,000Hz (25 — 20,000Hz ± 3dB)   | 20 — 20,000Hz (25 — 19,000Hz ± 3dB)  | 20 — 19,000Hz (20 — 18,000Hz ± 3dB)  | 25 — 17,000Hz (30 — 17,000Hz ± 3dB)  | 25 — 17,000Hz (30 — 16,000Hz ± 3dB)  |
| (0dB):                                    | 20 — 11,000Hz   | 20 — 11,000Hz  | 20 — 10,000Hz  | 25 — 9,000Hz   | 25 — 9,000Hz   |
| Metal tape (-20dB):                       | 20 — 23,000Hz (25 — 21,000Hz ± 3dB)   | 20 — 20,000Hz (25 — 20,000Hz ± 3dB)  | 20 — 20,000Hz (20 — 19,000Hz ± 3dB)  | 25 — 19,000Hz (30 — 18,000Hz ± 3dB)  | 25 — 18,000Hz (30 — 16,500Hz ± 3dB)  |
| (0dB):                                    | 20 — 16,000Hz   | 20 — 16,000Hz  | 20 — 15,000Hz  | 25 — 14,000Hz  | 25 — 14,000Hz  |
| Signal-to-Noise Ratio (Dolby off):        | 58dB*   | 57dB*  | 58dB*  | 58dB*  | 58dB*  |
| Harmonic Distortion (0dB):                | 0.8%  | 0.8%   | 0.8%   | 1.0%   | 1.0%   |
| Inputs (Sensitivity/Impedance)            |   |  |  |  |  |
| MIC (6mm jack x 2):                       | —   | —  | 0.25mV/600 ohms  | 0.25mV/600 ohms  | 0.25mV/600 ohms  |
| LINE (pin jack x 2):                      | 63mV/100k ohms  | 63mV/120k ohms   | 70mV/50k ohms  | 70mV/50k ohms  | 50mV/50k ohms  |
| Outputs (Reference level/Load impedance)  |   |  |  |  |  |
| LINE (pin jack x 2):                      | 630mV/7k ohms   | 630mV/3k ohms  | 700mV (max.)/10k ohms  | 450mV/10k ohms   | 450mV/3.2k ohms  |
| HEADPHONES (6mm stereo jack x 1):         | 0.45mW/8 ohms   | 0.45mW/8 ohms  | 0.8mW (max.)/8 ohms  | 0.3mW/8 ohms   | 0.25mW/8 ohms  |
| Power Requirement:                        | 120V 60Hz   | 120V 60Hz  | 120V 60Hz  | 120V 60Hz  | 120V 60Hz  |
| Power Consumption:                        | 54 watts  | 38 watts   | 55 watts   | 51 watts   | 31 watts   |
| Dimensions (W x H x D) (without package): | 16-9/16 x 5-1/8 x 14-3/4 inches<br>420 x 130 x 374 mm                                     | 16-9/16 x 5-1/8 x 14-3/4 inches<br>420 x 130 x 374 mm                                  | 16-9/16 x 4-3/4 x 14 inches<br>420 x 120 x 355 mm  | 16-9/16 x 4-3/4 x 14 inches<br>420 x 120 x 355 mm  | 16-9/16 x 4-3/4 x 11-3/16 inches<br>420 x 120 x 284 mm                           |
| Weight (without package):                 | 22 lbs. 1 oz./10kg  | 17 lbs. 7 oz./7.9kg  | 15 lbs. 14 oz./7.2kg   | 14 lbs. 9 oz./6.6kg  | 11 lbs. 14 oz./5.4kg   |

\*S/N is improved by 10dB with Dolby B and by 19dB with Dolby C (except CT-1040W and CT-301), both at 5kHz.

# Tuners

| A-40   | F-90  | F-70  | F-101T   |
|--|---|---|--|
| <b>FM SECTION</b>                            |   |   |  |
| Usable Sensitivity (mono):                   | 10.8dBf (0.95µV, 75 ohms)                                       | 10.8dBf (0.95µV, 75 ohms)                             | 10.8dBf (0.95µV, 75 ohms)                            |
| 50dB Quietening Sensitivity                  |   |   |  |
| Mono:  | 16.2dBf (1.8µV, 75 ohms)  | 16.2dBf (1.8µV, 75 ohms)                              | 17.3dBf (2.0µV, 75 ohms)                             |
| Stereo:                                      | 37.7dBf (21.0µV, 75 ohms)                                       | 37.2dBf (19.8µV, 75 ohms)                             | 39.2dBf (25µV, 75 ohms)                              |
| Signal-to-Noise Ratio                        |   |   |  |
| Mono/Stereo:                                 | 93dB/86dB (at 80dBf)  | 85dB/80dB (at 85dBf)                                  | 75dB/70dB (at 85dBf)                                 |
| Distortion                                   | (at 80dBf)  | (at 85dBf)  | (at 65dBf)   |
| 100Hz (mono/stereo):                         | 0.0095%/0.02%   | 0.05%/0.08%   | —  |
| 1kHz (mono/stereo):                          | 0.0095% (narrow; 0.09%)/<br>0.02% (narrow; 0.5%)<br>0.01%/0.07% | 0.05%/0.08%   | —/0.2%   |
| 10kHz (mono/stereo):                         | —   | 0.1%/0.2%   | —  |
| Frequency Response:                          | 20 — 15,000Hz +0.2dB, -0.8dB                                    | 30 — 15,000Hz +0.5dB, -1.0dB                          | 30 — 15,000Hz +0.5dB, -2.0dB                         |
| Capture Ratio:                               | 0.8dB   | 1.0dB   | 1.0dB  |
| Alternate Channel Selectivity:               | 85dB (400kHz)   | 56dB (400kHz)   | 70dB (400kHz)  |
| Muting Threshold:                            | 25.2dBf (5µV, 75 ohms)  | 30dBf (8.5µV, 75 ohms)                                | —  |
| Stereo Separation:                           | 65dB (1kHz),<br>50dB (20 — 10,000Hz) (narrow, 40dB)             | 50dB (1kHz),<br>35dB (50 — 10,000Hz)                  | 40dB (1kHz)  |
| Antenna Input:                               | 300 ohms balanced<br>75 ohms unbalanced                         | 300 ohms balanced<br>75 ohms unbalanced               | 300 ohms balanced<br>75 ohms unbalanced              |
| <b>AM SECTION</b>                            |   |   |  |
| Sensitivity                                  |   |   |  |
| IHF, Loop antenna:                           | 150µV/m   | 150µV/m   | 250µV/m  |
| Signal-to-Noise Ratio:                       | 50dB  | 50dB  | 50dB   |
| Antenna:                                     | Loop antenna  | Loop antenna  | Loop antenna   |
| <b>AUDIO SECTION</b>                         |   |   |  |
| Output (Level/Impedance)                     |   |   |  |
| FM (100% Mod, Fixed):                        | 650mV/600 ohms  | 650mV/1.7k ohms                                       | 650mV/7k ohms  |
| AM (30% Mod, Fixed):                         | 150mV/900 ohms  | 150mV/1.7k ohms                                       | 150mV/7k ohms  |
| <b>MISCELLANEOUS</b>                         |   |   |  |
| Power Requirement:                           | 120V 60Hz   | 120V 60Hz   | 120V 60Hz  |
| Power Consumption:                           | 14 watts  | 8 watts   | 15 watts   |
| Dimensions (W x H x D):<br>(without package) | 16-9/16 x 3-7/8 x 11-5/16 inches<br>420 x 61 x 317 mm           | 16-9/16 x 2-3/8 x 8-11/16 inches<br>420 x 60 x 221 mm | 16-9/16 x 2-3/8 x 12-1/2 inches<br>420 x 60 x 317 mm |
| Weight (without package):                    | 9 lbs. 15 oz./4.5kg   | 5 lbs. 8 oz./2.5kg                                    | 7 lbs. 15 oz./3.6kg                                  |

© beim Hersteller  
Archiv Michael Otto  
HiFi-Classics.de

| CT-40  | CT-501   | CT-301   | CT-1050W  | CT-1040W   |
|--|--|--|---|--|
| 4-track, 2-channel recording and playback stereo cassette tape deck  | 4-track, 2-channel recording and playback stereo cassette tape deck        | 4-track, 2-channel recording and playback stereo cassette tape deck        | 4-track, 2 channel double stereo cassette tape deck (recording/ playback & playback)  | 4-track, 2-channel double stereo cassette tape deck (recording/ playback & playback)   |
| DC-servo motor for capstan drive x 1,<br>DC motor for reel drive x 1   | DC-servo motor   | DC-servo motor   | DC-servo motor x 2  | 2-speed DC motor with electronic governor x 2  |
| "Hard Permalloy" recording/ playback head x 1,<br>Ferrite erasing head x 1   | "Hard Permalloy" recording/ playback head x 1,<br>Ferrite erasing head x 1 | "Hard Permalloy" recording/ playback head x 1,<br>Ferrite erasing head x 1 | "Hard Permalloy" recording/ playback head x 1, "Hard Permalloy" playback head x 1,<br>Ferrite erasing head x 1  | "Hard Permalloy" recording/ playback head x 1, "Hard Permalloy" playback head x 1,<br>Ferrite erasing head x 1   |
| 110 seconds  | 110 seconds  | 110 seconds  | 110 seconds   | 110 seconds  |
| 0.04%  | 0.06%  | 0.06%  | 0.06%   | 0.045%   |
| 25 — 15,000Hz<br>(35 — 14,000Hz ± 3dB)<br>25 — 15,500Hz<br>(35 — 15,000Hz ± 3dB)<br>35 — 10,000Hz<br>25 — 17,000Hz<br>(35 — 16,500Hz ± 3dB)<br>35 — 14,000Hz | 35 — 13,000Hz<br><br>35 — 14,000Hz<br><br>35 — 15,000Hz                    | 35 — 13,000Hz<br><br>35 — 14,000Hz<br><br>35 — 15,000Hz                    | 25 — 14,500Hz<br>(30 — 14,000Hz ± 3dB)<br>25 — 15,500Hz<br>(30 — 14,500Hz ± 3dB)<br>30 — 9,000Hz<br>25 — 16,000Hz<br>(30 — 15,000Hz ± 3dB)<br>30 — 14,000Hz | 25 — 15,000Hz<br>(35 — 14,000Hz ± 3dB)<br>25 — 15,500Hz<br>(35 — 15,000Hz ± 3dB)<br>35 — 10,000Hz<br>25 — 17,000Hz<br>(35 — 16,500Hz ± 3dB)<br>35 14,000Hz |
| 57dB*  | 57dB*  | 57dB*  | 57dB*   | 57dB*  |
| 1.0%   | 1.5%   | 1.5%   | 1.0%  | 1.0%   |
| 0.25mV/600 ohms<br>40mV/64k ohms   | 0.3mV/10k ohms<br>50mV/91k ohms  | 0.3mV/10k ohms<br>50mV/75k ohms  | —<br>50mV/50k ohms  | 1.4mV/600 ohms<br>50.7mV/71k ohms  |
| 450mV/1.9k ohms  | 316mV/3.9k ohms  | 330mV/50k ohms   | 320mV/10k ohms  | 450mV/2.8k ohms  |
| 0.27mW/8 ohms  | —  | —  | —   | 0.25mW/8 ohms  |
| 120V 60Hz  | 120V 60Hz  | 120V 60Hz  | 120V 60Hz   | 120V 60Hz  |
| 32 watts   | 16 watts   | 14 watts   | 17 watts  | 28 watts   |
| 16-9/16 x 3-15/16 x 11-7/16 inches<br>420 x 100.2 x 291 mm   | 16-9/16 x 4-3/4 x 9-3/8 inches<br>420 x 120 x 238 mm                       | 16-9/16 x 4-3/4 x 9-3/8 inches<br>420 x 120 x 238 mm                       | 16-9/16 x 4 x 12-3/8 inches<br>420 x 102 x 314.5 mm   | 16-9/16 x 4 x 12-3/8 inches<br>420 x 101.5 x 315 mm  |
| 10 lbs. 2 oz./4.6kg  | 8 lbs. 10 oz./3.9kg  | 8 lbs. 6 oz./3.8kg   | 12 lbs. 2 oz./5.5kg   | 15 lbs. 14 oz./7.2kg   |

## NOTE:

- (1) Reference tape: Normal and LH tapes are DIN 45513(Fe). Chrome tape is DIN 45513 (Cr).
- (2) Reference recording level is motor 0dB level. (160 nwb/m magnetic level=Philips cassette reference level.)
- (3) Reference signal is 315Hz.
- (4) Wow and Flutter: at 3kHz, WRMS (JIS), at 3,150Hz weighted PEAK (DIN 45507).
- (5) Frequency Responses are measured at -20dB and at 0dB levels respectively for reference recording level, Dolby off. Level deviation is ± 6dB (where not indicated). (DIN 45500)
- (6) Signal-to-Noise Ratio: Measured at the third harmonic distortion 3% level, weighted (DIN 45513/BLATT7)
- (7) Sensitivity: Input level (mV) for reference recording level measured with input (recording) level control set at maximum position.
- (8) Maximum allowable input level (mV) is measured at the point where the output signal wave is clipped while gradually turning the input level control.
- (9) Reference output level is LEDs display's 0dB level.
- (10) Maximum output (Playback) level: Output level to reference recording level, measured with an output (Playback) level control set at maximum position.

\* Specifications quoted for "metal" tapes are approximate. See manufacturers' data for individual tapes.

## Turntables

|  | PL-707  | PL-S70  | PL-S50  | PL-S40  |
|--|---|---|---|---|
| <b>MOTOR AND TURNTABLE</b>                   |   |   |   |   |
| Drive System:                                | Quartz-PLL direct-drive                                       | Quartz-PLL direct-drive                                       | Quartz-PLL direct-drive                                       | Quartz-PLL direct-drive                                       |
| Motor:                                       | Quartz-PLL Coreless DC-servo Stable Hanging Rotor™ Hall-motor | Quartz-PLL Coreless DC-servo Stable Hanging Rotor™ Hall-motor | Quartz-PLL Coreless DC-servo Stable Hanging Rotor™ Hall-motor | Quartz-PLL Coreless DC-servo Stable Hanging Rotor™ Hall-motor |
| Speeds:                                      | 33-1/3 and 45 rpm   | 33-1/3 and 45 rpm   | 33-1/3 and 45 rpm   | 33-1/3 and 45 rpm   |
| Wow and Flutter (WRMS):                      | 0.025%, 0.012% (FG*)  | 0.025%  | 0.025%  | 0.025%  |
| Signal-to-Noise Ratio (DIN B):               | 80dB  | 78dB  | 78dB  | 78dB  |
| <b>TONE ARM</b>                              |   |   |   |   |
| Type:  | Statically balanced, low mass straight PG™ pipe arm with DRA  | Statically balanced, low mass straight PG™ pipe arm with DRA  | Statically balanced, low mass straight PG™ pipe arm with DRA  | Statically balanced, low mass straight PG™ pipe arm with DRA  |
| Effective Arm Length:                        | 9-1/4 inches (235mm)  | 8-11/16 inches (221mm)  | 8-11/16 inches (221mm)  | 8-11/16 inches (221mm)  |
| Overhang:                                    | 9/16 inch (15mm)  | 5/8 inch (15.5mm)   | 5/8 inch (15.5mm)   | 5/8 inch (15.5mm)   |
| Usable Cartridge Weight:                     | 3g (min.) — 8.5g (max.)                                       | 3g (min.) — 8g (max.)   | 3g (min.) — 8g (max.)   | 3g (min.) — 8g (max.)   |
| <b>CARTRIDGE</b>                             |   |   |   |   |
| Type:  | —   | —   | —   | —   |
| Frequency Response:                          | —   | —   | —   | —   |
| Output Voltage:                              | —   | —   | —   | —   |
| Stylus:                                      | —   | —   | —   | —   |
| Tracking Force:                              | —   | —   | —   | —   |
| <b>MISCELLANEOUS</b>                         |   |   |   |   |
| Power Requirement:                           | 120V 60Hz   | 120V 60Hz   | 120V 60Hz   | 120V 60Hz   |
| Power Consumption:                           | 10W   | 8W  | 8W  | 8W  |
| Dimensions (W × H × D):<br>(without package) | 18-1/8 × 6-7/16 × 16-1/8 inches<br>460 × 164 × 409 mm         | 16-9/16 × 4-5/8 × 14-3/8 inches<br>420 × 118 × 365 mm         | 16-9/16 × 4-5/8 × 14-3/8 inches<br>420 × 118 × 365 mm         | 16-9/16 × 4-5/8 × 14-3/8 inches<br>420 × 118 × 365 mm         |
| Weight (without package):                    | 17 lbs. 14 oz./8.1kg  | 12 lbs. 9 oz./5.7kg   | 11 lbs. 14 oz./5.4kg  | 11 lbs. 11 oz./5.3kg  |

PG™ — Polymer Graphite™

DRA — Dynamic Resonance Absorber

\*FG — Measured directly from FG output

## Open-Reel Tape Decks

|  | RT-909   | RT-707  |
|--|--|---|
| Drive System:  | 3-motor drive system   | 3-motor drive system  |
| Operation:   | Solenoid drive, direct switchable function buttons and preset function buttons for timer recording and playback  | Solenoid drive, direct switchable function buttons and preset function buttons for timer recording and playback   |
| Motors:  | FG-servo DC motor × 1 (dual capstan drive),<br>6-pole inner-rotor special induction motor × 2 (reel drive)   | FG-servo AC direct drive motor × 1 (capstan drive),<br>6-pole inner-rotor induction motor × 2 (reel drive)  |
| Tape Heads:  | 4-track, 2-channel Ferrite erasing head × 1,<br>4-track, 2-channel Hard Permalloy recording head × 1,<br>4-track, 2-channel Hard Permalloy playback head × 1,<br>4-track, 2-channel Hard Permalloy reverse playback head × 1 | 4-track, 2-channel erasing head × 1,<br>4-track, 2-channel recording head × 1,<br>4-track, 2-channel playback head × 1,<br>4-track, 2-channel reverse playback head × 1 |
| Maximum Reel Size:   | 10-1/2-inch reel   | 7-inch reel   |
| Tape Speeds:   | 7-1/2 ips (19cm/sec.), 3-3/4 ips (9.5cm/sec.) ± 0.6%   | 7-1/2 ips (19cm/sec.) 3-3/4 ips (9.5cm/sec.) ± 0.5%   |
| Fast Winding Time:   | 120 seconds (10-1/2-inch reel, 720m)   | 100 seconds (7-inch reel, 370m)   |
| Wow and Flutter:   | 0.04% (WRMS) (at 7-1/2 ips, 19cm/sec.),<br>0.08% (WRMS) (at 3-3/4 ips, 9.5cm/sec.)   | 0.05% (WRMS) (at 7-1/2 ips, 19cm/sec.),<br>0.08% (WRMS) (at 3-3/4 ips, 9.5cm/sec.)  |
| Signal-to-Noise Ratio:                                       | 60dB (at 7-1/2 ips, 19cm/sec.), 55dB (at 3-3/4 ips, 9.5cm/sec.)  | 58dB (at 7-1/2 ips, 19cm/sec.)  |
| Harmonic Distortion:   | 1% (at 7-1/2 ips, 19cm/sec.)   | 1% (at 7-1/2 ips, 19cm/sec.)  |
| Frequency Response:  | 7-1/2 ips (19cm/sec.): 20 to 30,000Hz<br>(20 to 28,000Hz ± 3dB, LH tape)<br>3-3/4 ips (9.5cm/sec.): 20 to 20,000Hz<br>(20 to 18,000Hz ± 3dB, LH tape)  | 7-1/2 ips (19cm/sec.): 20 to 28,000Hz<br>(30 to 24,000Hz ± 3dB),<br>3-3/4 ips (9.5cm/sec.): 20 to 20,000Hz<br>(30 to 16,000Hz ± 3dB)                                    |
| Crosstalk:   | 50dB   | 50dB  |
| Stereo Channel Separation:                                   | 50dB   | 50dB  |
| Erasing Coefficient:   | 60dB   | 70dB  |
| Bias Frequency:  | 125kHz   | 125kHz  |
| Equalizer:   | NAB curve (7-1/2 ips, 19cm/sec., 3-3/4 ips, 9.5cm/sec.)  | NAB curve (7-1/2 ips, 19cm/sec., 3-3/4 ips, 9.5cm/sec.)   |
| Inputs (Sensitivity/Maximum allowable level/Input impedance) |  |   |
| MIC (6mm jack × 2):  | 0.316mV/80mV/27k ohms<br>(Reference MIC impedance: 250 ohms to 10k ohms)   | 0.25mV/125mV/27k ohms   |
| LINE (pin jack × 2):   | 50mV/25V/50k ohms  | 50mV/25V/100k ohms  |
| DIN (DIN standard):  | —  | 16mV/8V/1.3k ohms   |
| Outputs (Reference level/Maximum level/Load impedance)       |  |   |
| LINE (pin jack × 2):   | 450mV/900mV/2.6k ohms  | 450mV/700mV/50k ohms  |
| DIN (DIN standard):  | —  | 450mV/700mV/50k ohms  |
| HEADPHONES (6mm stereo jack × 1):                            | 50mV/100mV/8 to 250 ohms (with output level control)   | 70mV/8 ohms   |
| Power Requirement:   | 120V 60Hz  | 120V 60Hz   |
| Power Consumption:   | 166 watts (UL)   | 120 watts   |
| Dimensions (W × H × D):<br>(without package)                 | 18-7/8 × 13-3/8 × 12-1/2 inches<br>480 × 340 × 318 mm  | 18-7/8 × 9-1/16 × 14 inches<br>480 × 230 × 356 mm   |
| Weight (without package):                                    | 47 lbs. 6 oz./21.5kg   | 44 lbs. 1 oz./20kg  |

© beim Hersteller  
Archiv Michael Otto  
HiFi-Classic.de

| PL-S30   | PL-450   | PL-L800S  | PL-88FS  | PL-44FS   |
|--|--|---|--|---|
| Belt-drive   | Belt-drive   | Quartz-PLL direct-drive   | Quartz-PLL direct-drive  | Belt-drive  |
| DC-servo motor   | DC-servo motor   | Quartz-PLL Coreless DC-servo Stable Hanging Rotor™ Hall-motor                                 | Quartz-PLL Coreless DC-servo Stable Hanging Rotor™ Hall-motor              | DC-servo motor  |
| 33-1/3 and 45 rpm  | 33-1/3 and 45 rpm                                      | 33-1/3 and 45 rpm   | 33-1/3 and 45 rpm  | 33-1/3 and 45 rpm                                     |
| 0.05%  | 0.05%  | 0.025%, 0.012% (FG*)  | 0.025%, 0.012% (FG*)   | 0.045%  |
| 68dB   | 68dB   | 80dB  | 78dB   | 70dB  |
| Statically balanced, low mass straight PG™ pipe arm with DRA | Statically balanced, low mass straight pipe arm        | Statically balanced, linear motor driven, tangential tracking, low mass straight PG™ pipe arm | Statically balanced, direct-drive motor driven, low mass straight pipe arm | Statically balanced, low mass straight pipe arm       |
| 8-11/16 inches (221mm)                                       | 8-11/16 inches (221mm)                                 | 6-3/8 inches (162mm)  | 8-3/16 inches (208mm)  | 8-3/16 inches (208mm)                                 |
| 5/8 inch (15.5mm)  | 5/8 inch (15.5mm)                                      | 0   | 13/16 inch (20mm)  | 13/16 inch (20mm)                                     |
| 3g (min.) — 8g (max.)  |  | 3g (min.) — 8g (max.)   |  |   |
| —  | Plug-in (T4P), Moving-Magnet type (PC-250T)            | Moving-Coil type (PC-6MC)   | Moving-Coil type (PC-41MC)   | Moving-Coil type (PC-5MC)                             |
| —  | 10 — 30,000Hz  | 10 — 35,000Hz   | 10 — 35,000Hz  | 10 — 32,000Hz   |
| —  | 2.5mV  | 2.2mV   | 2.5mV  | 2.2mV   |
| —  | 0.6 mil diamond (PN-250T)                              | 0.3 x 0.7 mil diamond (PN-6MC)  | 0.3 x 0.7 mil diamond (PN-41MC)  | 0.5 mil diamond (PN-5MC)                              |
| —  | 1.25g ± 0.25g  | 2g ± 0.3g   | 2g ± 0.3g  | 2g ± 0.3g   |
| 120V 60Hz  | 120V 60Hz  | 120V 60Hz   | 120V 60Hz  | 120V 60Hz   |
| 2W   | 2W   | 22W   | 21W  | 13W   |
| 16-9/16 x 4-5/8 x 14-3/8 inches<br>420 x 118 x 365 mm        | 16-9/16 x 4-3/16 x 14-3/8 inches<br>420 x 106 x 365 mm | 16-9/16 x 4-3/4 x 16-13/16 inches<br>420 x 120 x 427 mm                                       | 16-9/16 x 3-7/8 x 13-3/16 inches<br>420 x 98 x 335 mm                      | 16-9/16 x 3-7/8 x 13-3/16 inches<br>420 x 98 x 335 mm |
| 9 lbs. 1 oz./4.1kg   | 8 lbs. 6 oz./3.8kg                                     | 18 lbs. 5 oz./8.3kg   | 22 lbs. 11 oz./10.3kg  | 19 lbs. 13 oz./9.0kg                                  |

© beim Hersteller  
Archiv Michael Otto  
HiFi-Classice.de

# Speaker Systems

|  | S-1010   | S-910   | S-710  | S-510   |
|--|--|---|--|---|
| Enclosure:                                   | Floor-standing type with passive radiator                          | Bass-reflex bookshelf type                            | Bass-reflex bookshelf type                               | Bass-reflex bookshelf type                                |
| Unit Layout:                                 | Symmetrical  | Symmetrical   | Symmetrical  | Symmetrical   |
| Speakers                                     |  |   |  |   |
| Woofer:                                      | 10-1/4-inch (26cm) PG™ cone type (14-inch (36cm) passive radiator) | 12-inch (30cm) PG™ cone type                          | 12-inch (30cm) PG™ cone type                             | 10-inch (25cm) PG™ cone type                              |
| Micrange:                                    | 2-1/2-inch (6.6cm) PG™ cone type                                   | 4-inch (10cm) PG™ cone type                           | 4-inch (10cm) PG™ cone type                              | 1-3/4-inch (4.5cm) PG™ cone type                          |
| Tweeter:                                     | Beryllium ribbon type  | Beryllium ribbon type                                 | Aluminum ribbon type                                     | Aluminum ribbon type                                      |
| Supertweeter:                                | —  | —   | —  | —   |
| Impedance:                                   | 6.3 ohms   | 6.3 ohms  | 6.3 ohms   | 6.3 ohms  |
| Frequency Range:                             | 28 — 50,000Hz  | 30 — 50,000Hz   | 33 — 50,000Hz  | 35 — 50,000Hz   |
| Sensitivity (1m):                            | 92.5dB/W   | 92.5dB/W  | 91.5dB/W   | 91dB/W  |
| Maximum Music Power:                         | 240W   | 240W  | 180W   | 120W  |
| Rated Power:                                 | 80W  | 80W   | 60W  | 40W   |
| Crossover Frequencies:                       | 1,500Hz (Low-Mid)<br>6,000Hz (Mid-High)                            | 1,300Hz (Low-Mid)<br>5,800Hz (Mid-High)               | 1,500Hz (Low-Mid)<br>12,000Hz (Mid-High)                 | 2,000Hz (Low-Mid)<br>13,000Hz (Mid-High)                  |
| Dimensions (W x H x D):<br>(without package) | 18-5/16 x 36-9/16 x 13-7/16 inches<br>465 x 928 x 341 mm           | 15-3/8 x 26-3/8 x 14-5/8 inches<br>390 x 670 x 371 mm | 14-9/16 x 25-9/16 x 12-9/16 inches<br>370 x 650 x 319 mm | 12-13/16 x 22-7/16 x 12-5/16 inches<br>325 x 570 x 313 mm |
| Weight (without package):                    | 82 lbs. 11 oz./37.5kg  | 50 lbs. 11 oz./23kg                                   | 38 lbs. 9 oz./17.5kg                                     | 26 lbs. 7 oz./12kg  |

## Add-On Components

### MA-100

|   |  |
|---|--|
| Inputs (Reference level/Impedance)                |  |
| Source, Tape:                                     | 85mV/50k ohms  |
| Ch-1 — 4 Mic:                                     | 0.4mV/50k ohms   |
| Guitar:   | 4mV/50k ohms   |
| Inst.:  | 38mV/50k ohms  |
| Output (Reference level/Impedance)                |  |
| Line out:   | 150mV/600 ohms   |
| Gain  |  |
| Source, Tape:                                     | 5dB  |
| Ch-1 — 4 (Mic/Guitar/Inst.):                      | 51dB/31dB/12dB   |
| Parametric Equalizer Section (CH-3, 4)            |  |
| Low:  | ± 10dB at 100 — 900Hz (variable)                       |
| High:   | ± 10dB at 1k — 13kHz (variable)                        |
| Echo Time:  | 3 sec. (max.)  |
| Total Harmonic Distortion:                        | 0.008% (1kHz, output 1.5V)                             |
| Signal-to-Noise Ratio (IHF, A-network, output 1V) |  |
| Source, Tape:                                     | 83dB   |
| Ch-1 — 4 (Mic, Guitar, Inst.):                    | 75dB   |
| Frequency Response (volume: — 3dB)                |  |
| Tape, Source:                                     | 10 — 80,000Hz 0dB, — 3dB                               |
| Ch-1 — 4 Mic:                                     | 150 — 20,000Hz   |
| Guitar, Inst.:                                    | 30 — 20,000Hz  |
| Power Requirement:                                | 120V 60Hz  |
| Power Consumption:                                | 15 watts   |
| Dimensions (W x H x D):<br>(without package)      | 16-9/16 x 6-1/4 x 8-15/16 inches<br>420 x 158 x 227 mm |
| Weight (without package):                         | 9 lbs. 4 oz./4.2kg                                     |

### CA-100

|   |  |
|---|--|
| Inputs (Reference level/Impedance)                |  |
| Source (acer; — 3dB):                             | 150mV/50k ohms                                       |
| Tape (fader; — 3dB):                              | 150mV/50k ohms                                       |
| Mic 1, 2:   | 0.3mV/25k ohms                                       |
| Outputs (Reference level/Impedance)               |  |
| Line:   | 150mV/330 ohms                                       |
| Rec:  | 150mV/2.5k ohms                                      |
| Gain  |  |
| Source, Tape/Mic:                                 | 3dB/53dB   |
| Graphic Equalizer Section                         |  |
| Equalizer Range:                                  | ± 10dB   |
| Center Frequencies:                               | 60Hz, 150Hz, 400Hz, 1kHz, 2.4kHz, 6kHz, 15kHz        |
| Echo Time (Mic):                                  | 2 sec. (max.)  |
| Frequency Response                                |  |
| Source, Tape:                                     | 10 — 80,000Hz 0dB, — 3dB                             |
| Mic 1, 2:   | 150 — 10,000Hz 0dB, — 3dB                            |
| Total Harmonic Distortion                         |  |
| Source, Tape:                                     | 0.01% (1kHz, output 1.5V)                            |
| Signal-to-Noise Ratio (IHF, A-network, output 1V) |  |
| Source, Tape:                                     | 90dB (Graphic Equalizer ON/<br>Volume center)        |
| Mic 1, 2:   | 69dB (Graphic Equalizer ON/<br>Volume center)        |
| Power Requirement:                                | 120V 60Hz  |
| Power Consumption:                                | 20 watts   |
| Dimensions (W x H x D):<br>(without package)      | 16-9/16 x 6-1/4 x 8-7/8 inches<br>420 x 158 x 226 mm |
| Weight (without package):                         | 9 lbs. 4 oz./4.2kg                                   |

### SG-90

|  |  |
|--|--|
| Equalizer Range:                             | ± 12dB ± 6dB (switchable)  |
| Center Frequencies:                          | 16, 25, 40, 63, 100, 160, 250, 400, 630, 1k, 1.5k, 2.5k, 4k, 6.3k, 10k, 16k, 25kHz |
| Total Harmonic Distortion:                   | 0.001% (20 — 20,000Hz, all controls flat, output 1V); 0dB (controls flat)          |
| Gain:  | 10 — 100,000Hz 0dB, — 2dB  |
| Frequency Response:                          | 120dB (output 2V)  |
| Signal-to-Noise Ratio (IHF, A-network):      | 114dB (output 1V)  |
| Input Impedance:                             | 47k ohms   |
| Output Impedance:                            | 200 ohms   |
| Power Requirement:                           | 120V 60Hz  |
| Power Consumption:                           | 25 watts   |
| Dimensions (W x H x D):<br>(without package) | 16-9/16 x 5-3/16 x 13-13/16 inches<br>420 x 131 x 351 mm                           |
| Weight (without package):                    | 15 lbs. 14 oz./7.2kg   |

### SG-540

|  |   |
|--|---|
| Equalizer Range:                             | ± 10dB  |
| Center Frequencies:                          | 50, 150, 400, 1k, 2.4k, 6k, 15kHz                   |
| Total Harmonic Distortion:                   | 0.005% (1kHz, all controls flat, output 1V)         |
| Gain:  | 0dB (controls flat)                                 |
| Maximum Output Voltage:                      | 6V (1kHz, T.H.D. 0.01%)                             |
| Frequency Response:                          | 5 — 70,000Hz 0dB, — 1dB                             |
| Signal-to-Noise Ratio:                       | 100dB (IHF, A-network, output 1V)                   |
| Input Impedance:                             | 50k ohms  |
| Output Impedance:                            | 600 ohms  |
| Power Requirement:                           | 120V 60Hz   |
| Power Consumption:                           | 10 watts  |
| Dimensions (W x H x D):<br>(without package) | 16-9/16 x 3-7/8 x 9-1/2 inches<br>420 x 98 x 241 mm |
| Weight (without package):                    | 6 lbs. 10 oz./3kg                                   |

### SR-60

|  |  |
|--|--|
| Reverberation Time (DEPTH volume control Min.) |  |
| Reverb:  | 0 — 3 sec. (400Hz)                                   |
| Echo:  | 0 — 3 sec. (400Hz)                                   |
| Duet:  | 100msec. (400Hz)                                     |
| Maximum Output Voltage:                        | 6.5V (1kHz, T.H.D. 0.01%)                            |
| Total Harmonic Distortion:                     | 0.005% (1kHz, REVERB LEVEL Min., output 1V)          |
| Input (sensitivity/impedance)                  |  |
| Reverb:  | 150mV/50k ohms                                       |
| Tape Play:                                     | 150mV/50k ohms                                       |
| Output (sensitivity/impedance)                 |  |
| Reverb:  | 150mV/220 ohms                                       |
| Tape Rec:                                      | 150mV/220 ohms                                       |
| Frequency Response:                            | 10 — 70,000Hz 0dB, — 1dB                             |
| S/N Ratio (IHF, A-network):                    | 104dB (output 2V), 98dB (output 1V)                  |
| Power Requirement:                             | 120V 60Hz  |
| Power Consumption:                             | 30 watts   |
| Dimensions (W x H x D):<br>(without package)   | 16-9/16 x 3-7/8 x 13-3/8 inches<br>420 x 99 x 340 mm |
| Weight (without package):                      | 10 lbs. 2 oz./4.6kg                                  |

### RG-60

|  |  |
|--|--|
| Dynamic Expansion:                           | 4, 7, 10, 13, 16dB   |
| Impulse Response                             |  |
| Attack Time:                                 | 0.3msec.   |
| Release Time:                                | 120msec.   |
| Maximum Output Voltage:                      | 6.5V (1kHz, T.H.D. 0.5%, R.; 50k ohms, Dynamic expansion 16dB) |
| Total Harmonic Distortion:                   | 0.05% (output 1V, 1kHz, Dynamic expansion 16dB)                |
| Gain   |  |
| Dynamic Expansion                            |  |
| Position:                                    | 4dB 7dB 10dB 13dB 16dB   |
| Upward Gain:                                 | +2dB +4dB +6dB +8dB +10dB                                      |
| Downward Gain:                               | -2dB -3dB -4dB -5dB -6dB                                       |
| Input Impedance:                             | 50k ohms (20 — 20,000Hz)                                       |
| Output Impedance:                            | 220 ohms (1kHz); 100dB (output 1V); 116dB (output 6.5V)        |
| S/N Ratio:                                   | (IHF, A-network, Dynamic expansion 16dB):                      |
| Power Requirement:                           | 120V 60Hz  |
| Power Consumption:                           | 10 watts   |
| Dimensions (W x H x D):<br>(without package) | 16-9/16 x 3-7/8 x 13-3/8 inches<br>420 x 99 x 340 mm           |
| Weight (without package):                    | 9 lbs. 15 oz./4.5kg  |

| CS-705   | CS-605   | CS-405  | S-T5  |
|--|--|---|---|
| Bass-reflex bookshelf type   | Bass-reflex bookshelf type   | Bass-reflex bookshelf type                              | Acoustic suspension bookshelf type                    |
| 15-3/4-inch (40cm) cone type   | 12-inch (30cm) cone type   | 12-inch (30cm) cone type                                | 6-1/2-inch (16cm) PG™ cone type                       |
| 4-3/4-inch (12cm) cone type<br>Horn type with acoustic lens<br>Ribbon type | 4-3/4-inch (12cm) cone type<br>Horn type with acoustic lens<br>Ribbon type | 4-inch (10cm) cone type<br>Aluminum ribbon type         | 1-inch (2.5cm) soft-dome type                         |
| 8 ohms   | 8 ohms   | 8 ohms  | 6.3 ohms  |
| 20 — 40,000Hz  | 25 — 40,000Hz  | 40 — 40,000Hz   | 45 — 20,000Hz   |
| 98dB/W   | 96dB/W   | 93dB/W  | 89dB/W  |
| 200W   | 150W   | 120W  | 90W   |
| 70W  | 50W  | 40W   | 30W   |
| 1,500Hz (Low-Mic)<br>5,000Hz (Mid-High)<br>8,000Hz (High-Superhigh)        | 2,000Hz (Low-Mid)<br>5,000Hz (Mid-High)<br>8,000Hz (High-Superhigh)        | 3,000Hz (Low-Mid)<br>10,000Hz (Mid-High)                | 2,000Hz (Low-High)                                    |
| 17-11/16 x 27-15/16 x 10-3/16 inches<br>450 x 710 x 259 mm                 | 16-1/8 x 25-7/16 x 10-15/16 inches<br>410 x 646 x 278 mm                   | 14-15/16 x 24-1/2 x 10-3/8 inches<br>380 x 630 x 263 mm | 7-3/16 x 10-1/8 x 7-3/16 inches<br>182 x 257 x 182 mm |
| 44 lbs. 1 oz./2Ckg   | 35 lbs. 4 oz./16kg   | 24 lbs. 4 oz./11kg                                      | 9 lbs. 15 oz./4.5kg                                   |

#### Speaker Power Handling Capability vs. Amplifier Output Power

Normally, speakers will not be damaged even if the output power of an amplifier exceeds the speakers' allowable input power, on the condition that the amplifier is kept below its clipping level\*. (Use care when increasing the volume level if the amplifier has an extremely high power rating.)

There is however, a chance that the tweeter may be damaged when the amplifier is pushed beyond its clipping level even if the amplifier's power rating is below the speakers' allowable input power.

It is therefore important to consider the allowable input power of your speakers (=maximum music power) when selecting an amplifier, and at the same time, the amplifier must be operating below its clipping level at all times.

\*Clipping level: The power level at which severe distortion suddenly appears due to attempts to drive an amplifier beyond its capacity.

#### SG-60

|                            |   |
|----------------------------|---|
| Equalizer Range:           | ± 12dB  |
| Center Frequencies:        | 16, 32, 64, 125, 250, 500, 1k, 2k, 4k, 8k, 16k, 32kHz |
| Total Harmonic Distortion: | 0.003% (16 — 32,000Hz, all controls flat, output 1V)  |
| Gain:                      | 0dB (controls flat)                                   |
| Frequency Response:        | 10 — 100,000Hz 0dB, — 2dB                             |
| Signal-to-Noise Ratio:     | 120dB (output 2V)                                     |
| (IHF, A-network)           | 114dB (output 1V)                                     |
| Input Impedance:           | 50k ohms  |
| Output Impedance:          | 200 ohms  |
| Power Requirement:         | 120V 60Hz   |
| Power Consumption:         | 25 watts  |
| Dimensions (W x H x D):    | 16-9/16 x 5-3/16 x 13-13/16 inches                    |
| (without package)          | 420 x 131 x 351 mm                                    |
| Weight (without package):  | 13 lbs. 4 oz./6kg                                     |

#### SG-50(M)

|                                  |  |
|----------------------------------|--|
| Inputs (Sensitivity/Impedance)   |  |
| LINE IN:                         | 150mV/50k ohms                               |
| TAPE PLAY:                       | 150mV/50k ohms                               |
| MIC:                             | 0.1mV/5k ohms                                |
| Outputs (Level/Impedance)        |  |
| LINE OUT:                        | 150mV/1k ohms                                |
| TAPE REC:                        | 150mV  |
| <b>Graphic Equalizer Section</b> |  |
| Equalizer Range:                 | ± 10dB                                       |
| Center Frequencies:              | 32, 64, 125, 250, 500, 1k, 2k, 4k, 8k, 16kHz |
| Frequency Response               |  |
| LINE IN, TAPE PLAY:              | 5 — 100,000Hz 0dB, — 3dB                     |
| Signal-to-Noise Ratio:           | 116dB  |
| (IHF, A-network, output 2V)      |  |
| Total Harmonic Distortion:       | 0.003% (20 — 20,000Hz, output 2V)            |
| Gain:                            | 0dB (controls flat)                          |
| <b>Spectrum Analyzer Section</b> |  |
| Display Resolution:              | 3dB (x 8)                                    |
| Center Frequencies:              | 32, 64, 125, 250, 500, 1k, 2k, 4k, 8k, 16kHz |
| <b>Miscellaneous</b>             |  |
| Power Requirement:               | 120V 60Hz                                    |
| Power Consumption:               | 16 watts                                     |
| Dimensions (W x H x D):          | 16-9/16 x 3-7/8 x 10-1/2 inches              |
| (without package)                | 420 x 98 x 266 mm                            |
| Weight (without package):        | 9 lbs. 11 oz./4.4kg                          |

#### DT-540

|                           |  |
|---------------------------|--|
| Timer Type:               | 24-hour type (12-hour display and AM/PM)   |
| Timer Set:                | Only one ON/OFF time setting in minimum units of minutes within a 24-hour period |
| Timer Setting Interval:   | 1 minute   |
| Sleep Timer Set:          | 1 minute — 1 hour 59 minutes   |
| Accuracy of Timer:        | ± 0.1 second (delay time to displayed time)                                      |
| Accuracy of Sleep Timer:  | No more than 59 seconds (delay time for OFF to display time)                     |
| AC Outlet Capacity Power: | 500 watts (max.)   |
| Power Requirement:        | 120V 60Hz  |
| Power Consumption:        | 6 watts  |
| Dimensions (W x H x D):   | 16-9/16 x 2-1/16 x 5-9/16 inches   |
| (without package)         | 420 x 52 x 142 mm  |
| Weight (without package): | 3 lbs. 12 oz./1.7kg  |



**PIONEER ELECTRONICS (USA) INC.**  
P.O. Box 1540, Long Beach, California 90801

To find your nearest dealer for any Pioneer product,  
call 1 (800) 447-4700, toll free in the United States,  
except Alaska and Hawaii.

© beim Hersteller  
Archiv Michael Otto  
HiFi-Classik.de