

**The Harman-Kardon  
Model 930**

---

**AM/FM/Stereo FM  
Solid State Receiver**

**Technical Manual**

**harman/kardon**



# FM IC BOARD

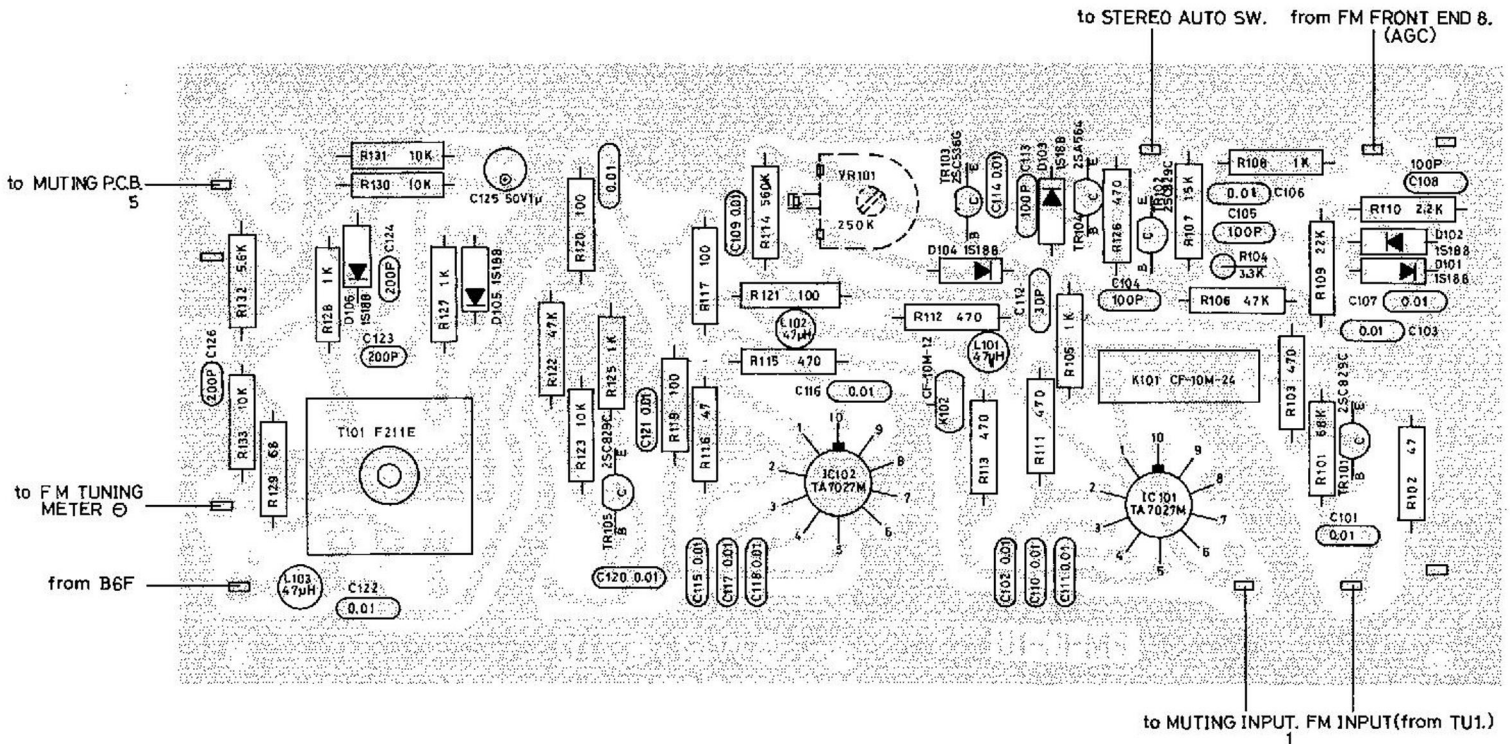

# AM RF BOARD

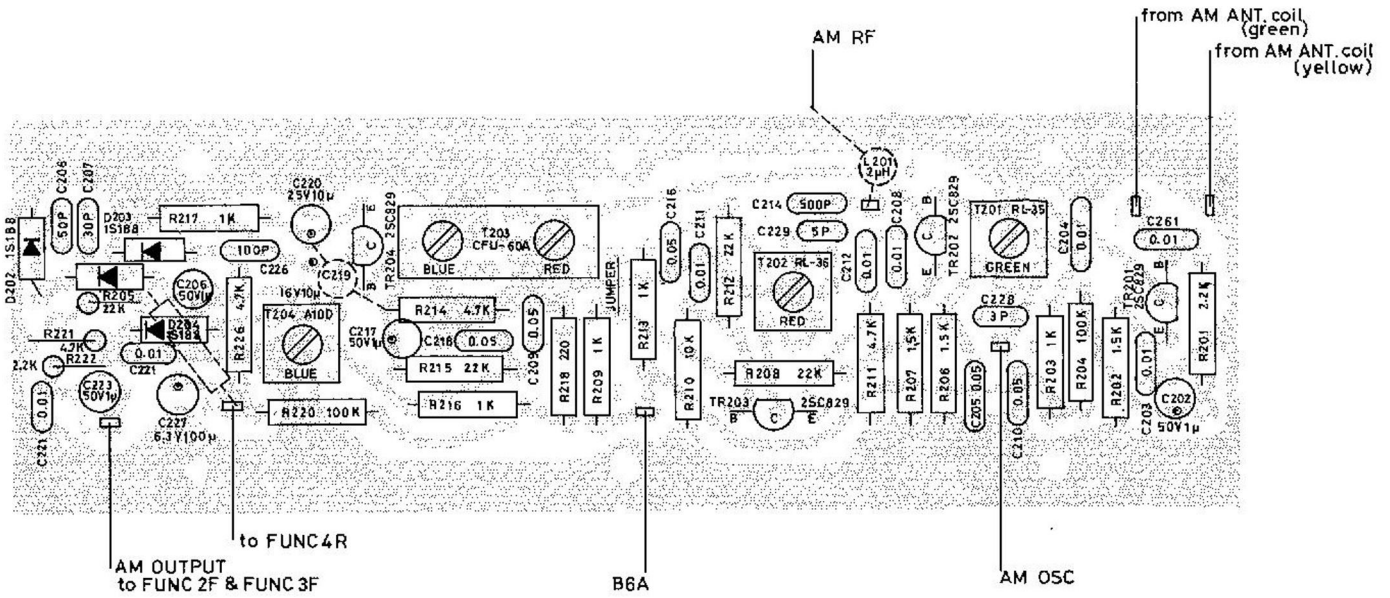

## FM ALIGNMENT

**INSTRUMENTS:** FM SIGNAL GENERATOR, VTVM OSCILLOSCOPE  
DISTORTION METER  
SET, SELECTOR TO FM AUTO

STEPS	FM SIGNAL GENERATOR		TUNING DIAL SETTING	OUTPUT INDICATOR CONNECTED TO	ADJUST	ADJUST FOR	
	CONNECTED TO	FREQUENCY					
1	NO SIGNAL INPUT		90 MHz	VTVM & Oscilloscope at Tape output	T102 (TOP)	Zero center meter must be Zero NOTE: Must not be tuned to stations	
2	FM Antenna terminal	90 MHz CW Weakest signal possible			106 MHz	LO, LA, LR1, LR2, T101 TOP & Bottom T102 Bottom	Maximum reading on Signal Strength Meter
3		106 MHz CW Weakest Signal possible				CT4, CT5, CT6, CT7, T101 TOP & Bottom	
4	Repeat steps 1, 2 & 3 until no further improvement is possible						
5	FM Antenna terminal	90 MHz 400 Hz 100% MOD	90 MHz	VTVM & Oscilloscope at Tape output	T102 Bottom	Minimum Distortion	
6		90 MHz 400 Hz 100% MOD 50uV	90 MHz		FM Meter Level Pot	25% Distortion	
7		90 MHz CW	90 MHz	Collector of TR705	L702	Minimum DC Voltage	

## AM ALIGNMENT

**INSTRUMENTS:** AM SIGNAL GENERATOR, VTVM  
SET SELECTOR SWITCH TO "AM"

INPUT SIGNAL MUST BE KEPT AS LOW AS POSSIBLE TO AVOID AVC ACTION EXCEPT STEP 5.

STEPS	SIGNAL GENERATOR		TUNING DIAL SETTING	OUTPUT INDICATOR CONNECTED TO	ADJUST	ADJUST FOR
	CONNECTED TO	FREQUENCY				
1	TR203 Base Through A0.01uF	455 KHz (400Hz 30% MOD)	Quiet point on the BAND	VTVM & Oscilloscope	T203 (Primary & Secondary & T204)	Maximum reading & Minimum Distortion
2	Use loop Antenna	600 KHz (400 Hz 30% MOD)	600 KHz		T202 (OSC) & L904 T201	Maximum reading
3		1400 KHz (400 Hz 30% MOD)	1400 KHz		CT3 (OSC) & CT1, CT2	
4	Repeat steps 2 & 3 until no further improvement is possible.					
5	Use loop Antenna (input signal level 10 <sup>mv</sup> /m)	600 KHz (400 Hz 30% MOD)	600 KHz	VTVM & Oscilloscope	T204	Minimum distortion

## MPX ALIGNMENT

**INSTRUMENTS:** STEREO GENERATOR, OSCILLOSCOPE, VTVM

SET SELECTOR SWITCH TO "FM"  
FM AUTO SWITCH TO AUTO  
MODE SWITCH TO STEREO

TUNING DIAL SETTING: STEREO SIGNAL GENERATOR  
STEREO PILOT ADJUST (VR301) SET TO MID POSITION.

SET SEPARATION CONTROL (VR302) MAX POSITION COUNTERCLOCKWISE

STEPS	19KHz PILOT LEVEL	SIGNAL GENERATOR FREQ. SET TO	OUTPUT INDICATOR CONNECTED TO	ADJUST	ADJUST FOR
1	6%	STEREO Generator 19KHz	Use only low capacity scope probe TP3	L301 L302	Maximum 30KHz at TP3
2	6%	100Hz composite L-channel	Adjust VR 301 till STEREO beacon lamp just comes ON		
3	Repeat 1 & 2 until no further change				
4	9%	1000Hz composite L-channel	Scope probe to TP3 VTVM to R-channel T. OUT	L302	Minimum at Tape Out & Maximum at TP3 simultane- ously
5	9%	1000Hz L-channel	Scope probe to TP3 VTVM to R-channel T. OUT	L303	Read separa- tion, remove scope probe, adjust L303 CW until same separation. Do not try for better amount.
6	9%	1000Hz L-composite	R, L. Channel TAPE OUT	VR302	Equal L & R separation
7	Adjust separation control VR302 1F if necessary				

## FM STEREO THRESHOLD ADJUSTMENT

**INSTRUMENTS:** FM STEREO SIGNAL GENERATOR, VTVM, OSCILLOSCOPE.

SET SELECTOR SWITCH TO FM. STEREO AUTO SWITCH TO STEREO.

STEPS	FM STEREO SIGNAL GENERATOR		OUTPUT INDICATOR CONNECTED TO	ADJUST	ADJUST FOR
	CONNECTED TO	SIGNAL STRENGTH			
1	FM Antenna Terminal	70uV	Oscilloscope to Tape output	VR101	Must be STEREO
2		<70uV		Check	Must be MONO

## MUTING ADJUSTMENT

STEPS	CONDITION	ANTENNA INPUT	OUTPUT INDICATOR CONNECTED TO	ADJUST	ADJUST FOR
1	Muting Switch OFF	10uA	Oscilloscope TAPE OUTPUT		Check output
2	Muting Switch ONN	10uV		Muting VR Control VR702	Adjust VR702 Clockwise until output is just distinguished

## AUDIO DRIVER BIAS ADJUSTMENT

- (1) Set volume control to minimum position.
- (2) Connect 8 ohm load resistor to speaker terminals in parallel.
- (3) Connect 30mV DC millivolt meter to left channel test point TP1 (R617)
- (4) Adjust bias control VR601 counterclockwise until millivolt meter indicates 15mV.
- (5) Change millivolt meter from left channel to right channel.
- (6) Adjust bias control VR21 counterclockwise until millivolt meter indicates 15mV.

TOP VIEW

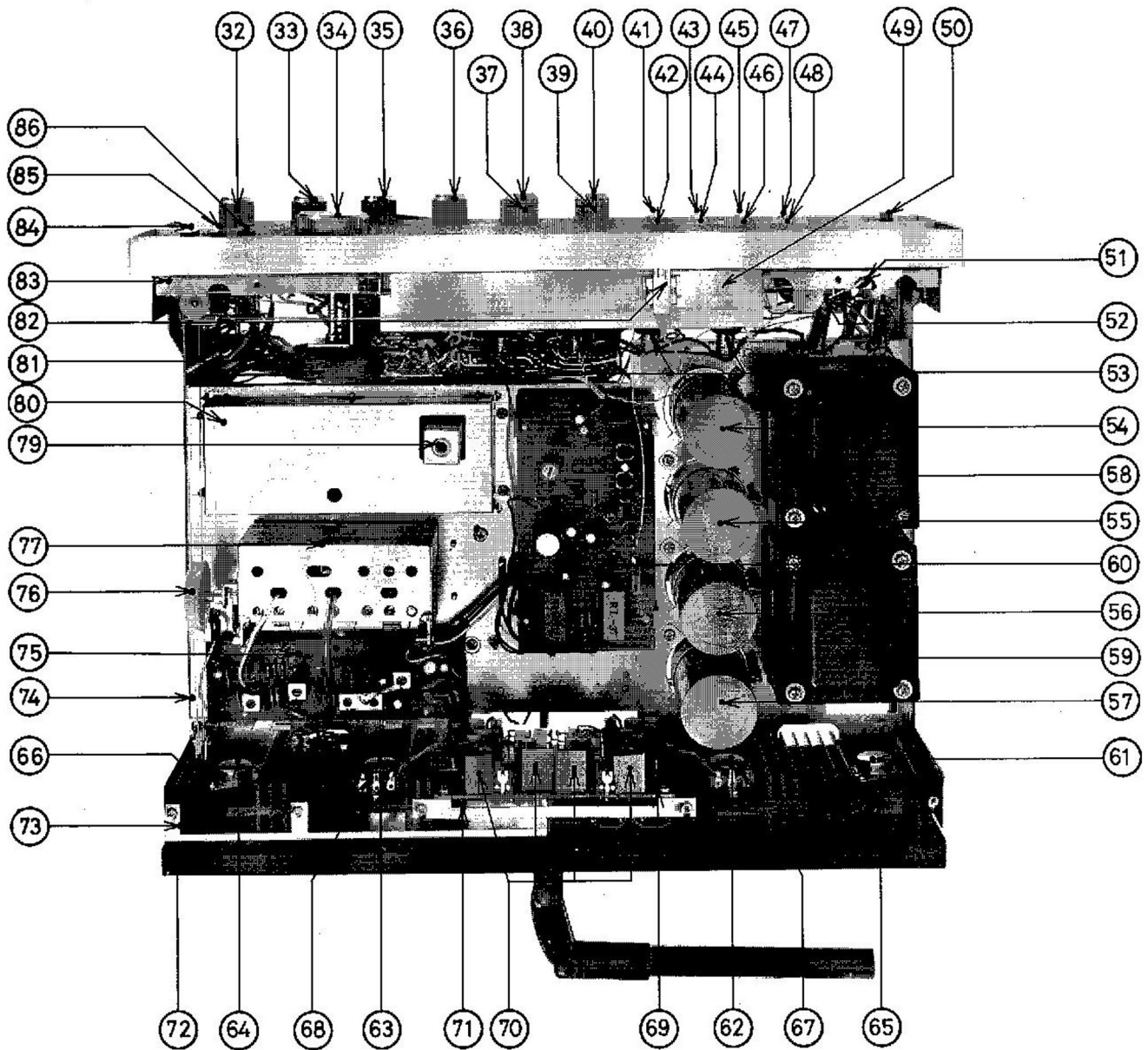

- 32 FUNCTION SWITCH
- 33 MODE SWITCH
- 34 TUNING
- 35 VOLUME CONTROL
- 36 BALANCE CONTROL
- 37 TREBLE CONTROL (R-CHANNEL)
- 38 TREBLE CONTROL (L-CHANNEL)
- 39 BASS CONTROL (R-CHANNEL)
- 40 BASS CONTROL (L-CHANNEL)
- 41 TONE DEFEAT SWITCH
- 42 CONTOUR SWITCH
- 43 LOW-CUT SWITCH
- 44 HIGH-CUT SWITCH
- 45 TAPE-MONITOR-2 SWITCH
- 46 TAPE-MONITOR-1 SWITCH
- 47 SPEAKERS-2 SWITCH
- 48 SPEAKERS-1 SWITCH
- 49 DIAL LAMP HOUSING

- 50 POWER SWITCH
- 51 STEREO INDICATOR LAMP
- 52 METER LAMP
- 53 DIAL LAMP
- 54 C905 (50V 6800uf)
- 55 C906 (50V 6800uf)
- 56 C907 (50V 6800uf)
- 57 C908 (50V 6800uf)
- 58 POWER TRANSFORMER (T901)
- 59 POWER TRANSFORMER (T902)
- 60 MPX PCB
- 61 POWER TRANSISTOR (TR901)
- 62 POWER TRANSISTOR (TR902)
- 63 POWER TRANSISTOR (TR904)
- 64 POWER TRANSISTOR (TR903)
- 65 HEAT SINK
- 66 HEAT SINK
- 67 THERMISTER

- 68 THERMISTER (D621, D622)
- 69 AF PCB
- 70 TRANSISTOR COVER
- 71 AF PCB HOLDER
- 72 CHASSIS REAR
- 73 PHONO INPUT SHIELD COVER
- 74 CHASSIS
- 75 AM RF PCB
- 76 DIAL DRUM
- 77 AM FM FRONT END
- 86 FM MUTING SWITCH
- 79 DISCRIMINATOR SECONDARY
- 80 FM IC PCB TOP COVER
- 81 FLYWHEEL
- 82 DIAL POINTER
- 83 FRONT CHASSIS
- 84 STEREO AUTO SWITCH
- 85 MPX FILTER SWITCH

**BOTTOM VIEW**

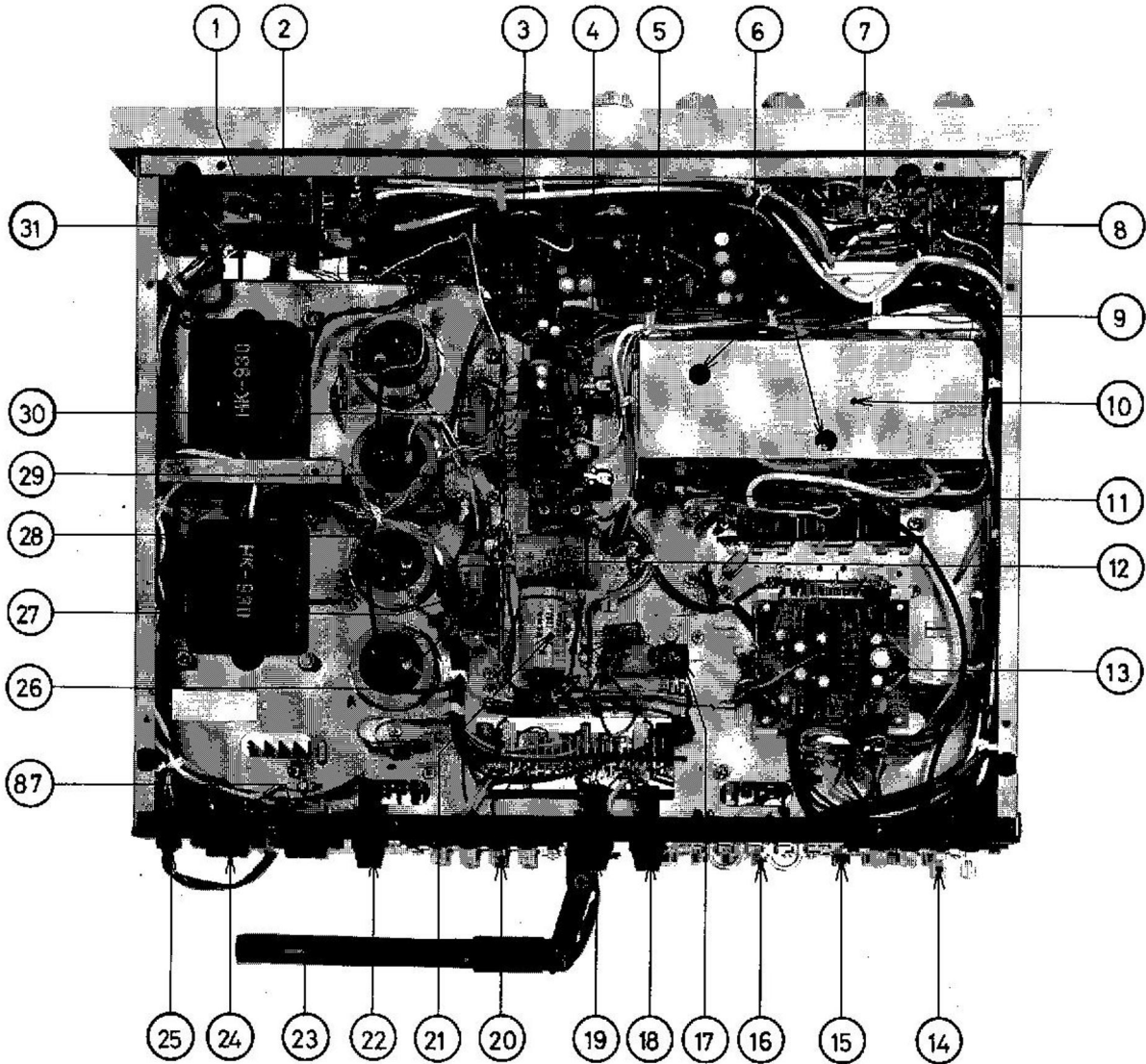

- |                               |                            |                              |
|-------------------------------|----------------------------|------------------------------|
| ① PHONE JACK                  | ⑪ BRACKET FOR BOTTOM PLATE | ⑳ C910                       |
| ② SPEAKER SWITCH SHIELD COVER | ⑫ C909                     | ㉑ AC FUSE                    |
| ③ POWER SUPPLY DIODE (D903)   | ⑬ PRE AMP PCB              | ⑳ AM LOOP STICK ANTENNA L901 |
| ④ MUTING PCB                  | ⑭ ANTENNA TERMINAL         | ㉒ AC OUTLET                  |
| ⑤ TONE CONTROL PCB            | ⑮ INPUT TERMINALS          | ㉓ AC LINE CORD HOLDER        |
| ⑥ DISCRIMINATOR PRIMARY       | ⑯ PRE OUT & MAIN IN        | ㉔ POWER SUPPLY DIODE (D905)  |
| ⑦ MODE SWITCH                 | ⑰ TR905 2SC931             | ㉕ C920                       |
| ⑧ FUNCTION SWITCH             | ⑱ SPEAKER FUSE (L-CHANNEL) | ㉖ POWER SUPPLY DIODE (D904)  |
| ⑨ STEREO THRESHOLD            | ㉒ SPEAKER FUSE (R-CHANNEL) | ㉗ POWER SUPPLY DIODE (D906)  |
| ⑩ FM IC PCB BOTTOM COVER      | ㉓ SPEAKER TERMINAL         | ㉘ C921                       |
|                               |                            | ㉙ POWER SWITCH               |
|                               |                            | ㉚ AC OUTLET                  |

**AM/FM FRONT END (FL412U13)  
SCHEMATIC — MODEL 930**

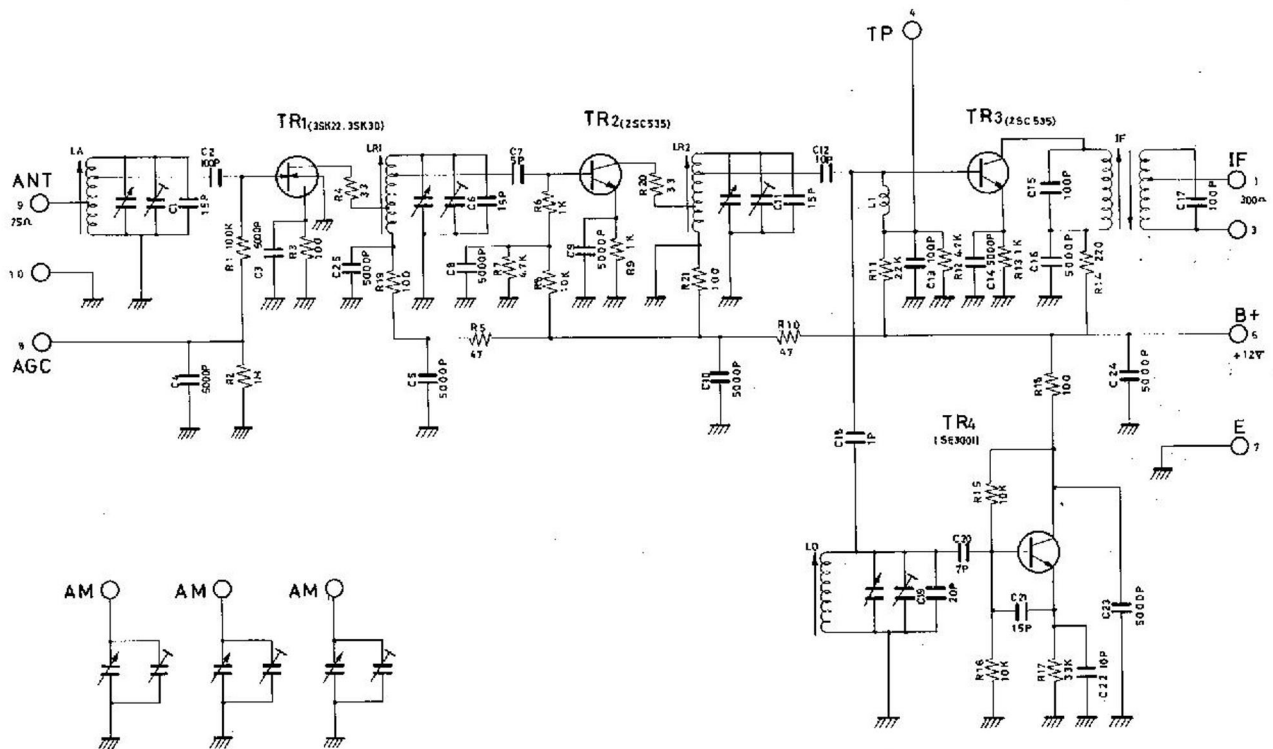

**AM/FM FRONT END (FL412U13)**

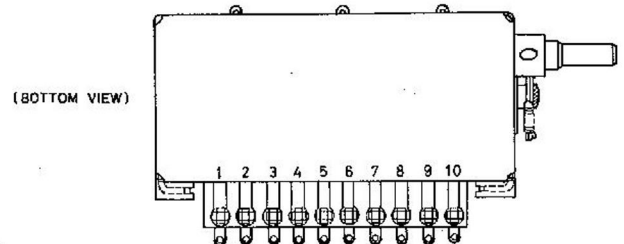
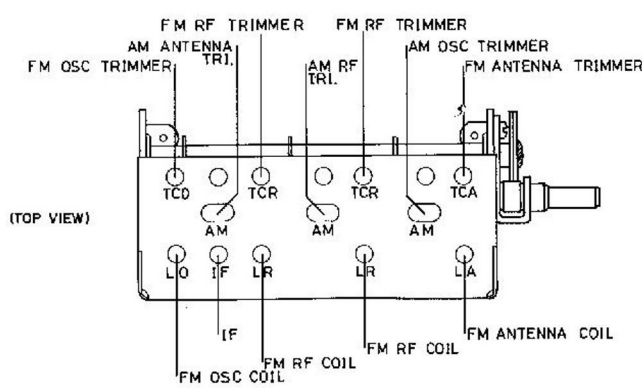

**DESCRIPTION OF TERMINAL PINS**

- |                    |                    |
|--------------------|--------------------|
| (1) IF HOT         | (6) NON CONNECTION |
| (2) NON CONNECTION | (7) GND            |
| (3) IF COLD        | (8) AGC            |
| (4) TEST POINT     | 9 ANTENNA          |
| (5) B + 12V        | (10) GND           |

**SCHEMATIC DIAGRAM — MODEL 930**

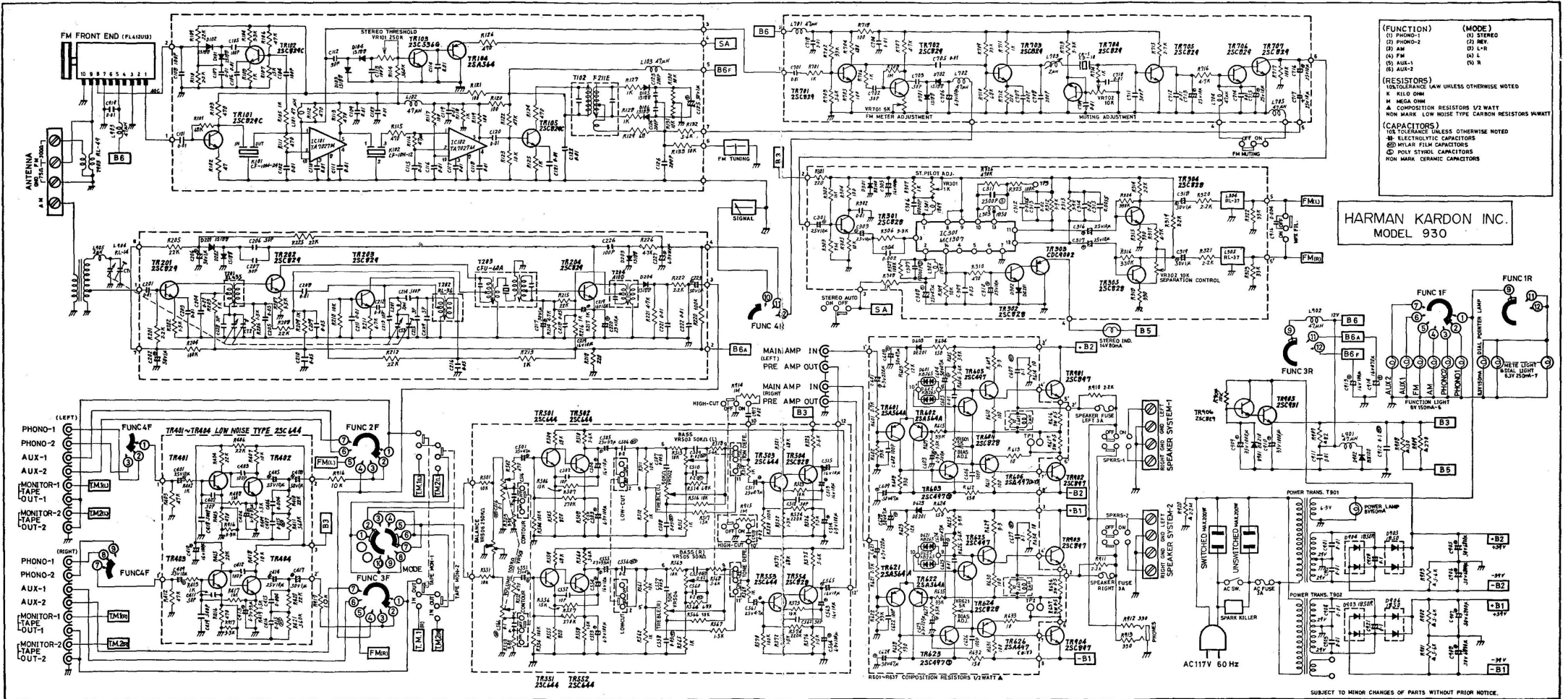

- |             |            |
|-------------|------------|
| (FUNCTION)  | (MODE)     |
| (1) PHONO-1 | (1) STEREO |
| (2) PHONO-2 | (2) MONO   |
| (3) AM      | (3) L      |
| (4) FM      | (4) L      |
| (5) AUX-1   | (5) L      |
| (6) AUX-2   | (6) L      |
- (RESISTORS)  
 (1) TOLERANCE 5% UNLESS OTHERWISE NOTED  
 K KILO OHM  
 M MEGA OHM  
 A COMPOSITION RESISTORS 1/2 WATT  
 NON MARK LOW NOISE TYPE CARBON RESISTORS 1/4 WATT
- (CAPACITORS)  
 (1) TOLERANCE 5% UNLESS OTHERWISE NOTED  
 E ELECTROLYTIC CAPACITORS  
 M MILAR FILM CAPACITORS  
 P POLY STYROL CAPACITORS  
 N NON MARK CERAMIC CAPACITORS

**HARMAN KARDON INC.  
 MODEL 930**

# PREDRIVER BOARD

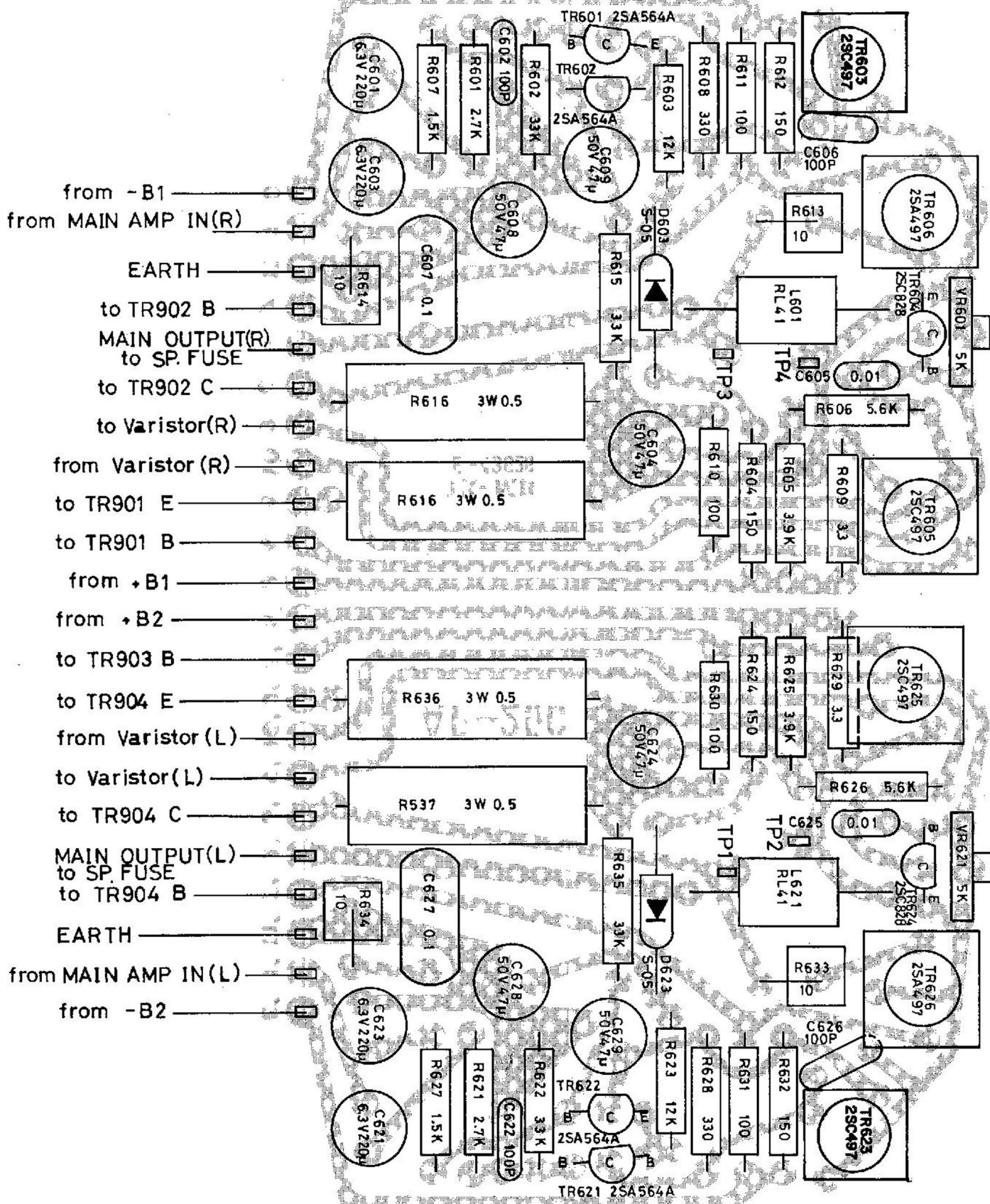

# MUTING BOARD

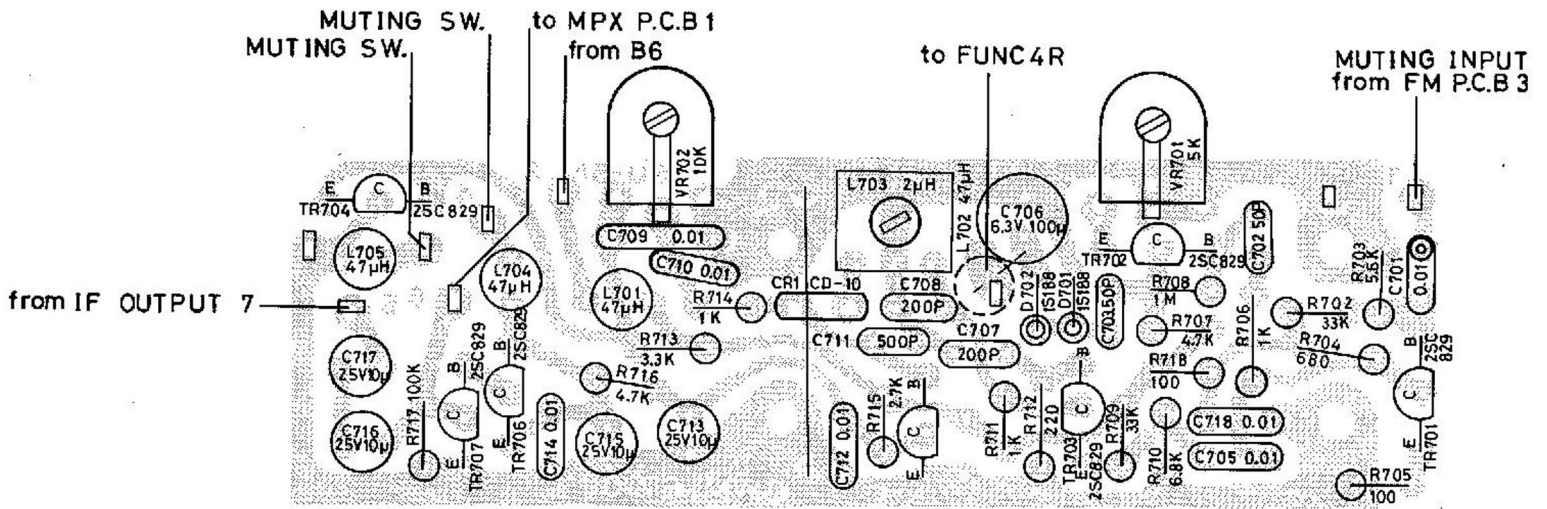

# STRINGING DIAGRAM

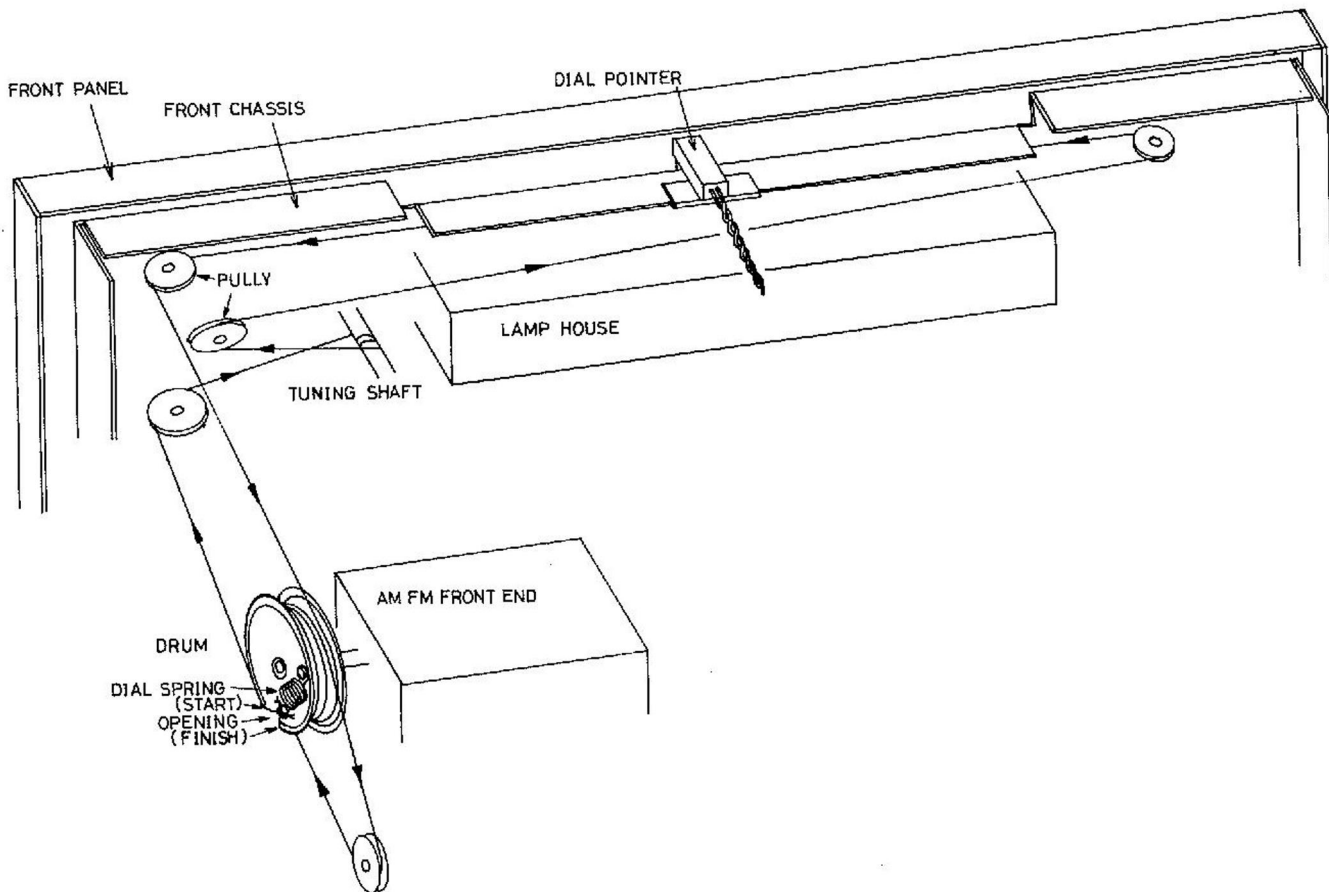



## REPLACEMENT PARTS LIST

H-K PART NO.	REF. NO.	DESCRIPTION	H-K PART NO.	REF. NO.	DESCRIPTION
<b>TRANSFORMERS &amp; COILS</b>					
10128098	---	Power Transformer	43024216	TR901-04	Transistor, 2SC897 (Power)
11028257	T102	FM Det. Can	43026932	TR905	Transistor, 2SC931C
11024831	T204	IFT, AM Det.	43025972	TR103	Transistor, 2SC536G
12028099	---	Coil, Bar Antenna, RL-38A	43025614	TR605/6/25/26	Transistor, 2SC497
12028100	T201	Coil, AM RF, RL-35	43025613	TR604, 624	Transistor, 2SA497
12028101	T202	Coil, AM Osc. RL-36	43027722	TR303	Transistor, CDC9002
12028140	L601/621	Coil, speaker, RL-41	43025972	TR301/2/504/554/828, 624,305,906	Transistor, 2SC828
12028102	L304/305	Coil, Multi-Filter, RL-37	43025613	TR104,601/2/621/22	Transistor, 2SA564A
12028141	L703	Coil, Muting, RL-47	38128120	D601/2/621/22	Varistor, KB265
12028103	L301/302	Coil, Multiplex, 19 KHz	<b>MISCELLANEOUS</b>		
12028104	L303	Coil, Multiplex, 38 KHz	00228097	FL412V13	AM/FM Front-End Tuner
12028105	L201	Coil, Choke, RL-49	63028081	---	Escutcheon Assy.
12028117	K101	Ceramic Filter, CF-10M-24 10.7MHz	61628082	---	Top Plexiglas, Dial
12026545	K102	Ceramic Filter, CF-10M-12 10.7MHz	61628083	---	Top Plexiglas, Switches (small)
12028118	T203	Ceramic Filter, 455 KHz	60728084	---	Dial Pointer
12028144	CR-1	Ceramic Resonator, CD-10	12528085	---	Tuning Meter, FM Zero Center
11027970	T903	Balun, FM Matching Trans.	12528086	---	Tuning Meter, AM Signal Strength
12028124	L101-03/701/02/04/05	Micro Inductor, 47UH	60228159	---	Heat Sink, Power Amp
<b>DIODES</b>					
42028106	D301	Diode, Zener, BZ-140 (14V)	63228087	---	Knob, Single (Function, Mode Volume, Balance)
42028107	D902	Diode, Zener, BZ-120 (12V)	63228088	---	Knob, Dual, Front (Bass & Treble)
42028108	D901	Diode, Zener, BZ-210 (21V)	63228089	---	Knob, Dual, Rear (Bass & Treble)
41027991	D905,906	Diode, 1S1850	63228090	---	Knob, Tuning
41028109	D904,903	Diode, 1S1850R	63228091	---	Knob, Round Push Button
41025629	D302, 603, 623	Diode, S-05-02 (DEZ01)	63228092	---	Knob, Power
41025628	D101-06/201-04/701/02	Diode, 1S188	24028093	---	Switch, Function
<b>CONTROLS</b>					
22028121	VR501	VR, Volume, 100K	24028113	---	Switch, Mode
22028122	VR502-03	VR, Bass & Treble, 50K	25027921	---	Switch, Power
21528123	VR506	VR, Balance, 250K	63228110	---	Switch, 2-gang Push
23528125	TR91R/VR601/621/701	Potentiometer, 5K	63228111	---	Switch, 3-gang Push (w. Buttons)
23528126	TR92R/VR101	Potentiometer, 250K	60428094	---	Flywheel w/ shaft
23528127	VR301	Potentiometer, 1K	65424917	---	Headphone Jack
23528128	VR702	Potentiometer, 10K	65424895	---	Fuse Holder
23528129	VR302	Potentiometer, 10K	65424896	---	AC outlet
<b>TRANSISTORS</b>					
43125611	IC-101/102	IC, TA7027M	62018160	---	Plastic Foot
43126551	IC-301	IC, M1307P	46528095	---	Bulb, Dial Scale, 6.3V 250MA
			46524955	---	Bulb, Meter, 6.3V 250MA
			46527254	---	Bulb, Function Indicator 8V 150MA
			46527892	---	Bulb, Stereo Indicator 14V 80MA

NOTE: To speed handling of your order be sure to include both the model and serial numbers which appear at the back of the chassis, in addition to the quantity, part number and part description of the items ordered. Orders from independent dealers, independent servicemen, and retail customers will be shipped on a cash in advance basis. Harman-Kardon

reserves the right to substitute equivalent parts for those originally installed in this chassis. All parts should be ordered from Harman-Kardon, 55 Ames Court, Plainview, L.I., N.Y. 11803, Att: Parts Department.