

# DESIGN OF TRANSCRIPTION TURNTABLES

By E W MORTIMER  
*Garrard Engineering Limited*

THE term transcription as applied to gramophone turntables describes those of the highest possible quality and reliability. Turntables in this class are used for professional purposes, such as in radio, television and recording studios, schools, ship installations and by audio enthusiasts who require the very best.

The quality is primarily assessed by the degree of wow and flutter (fluctuations in speed), and rumble (unwanted background noise), generated by the turntable whilst playing a record. Accuracy of speed regulation and its stability, limitation of external magnetic field from the electric motor and the suppression of electrical interference such as can occur when breaking the switch contacts, are also some of the additional factors in assessing performance.

A transcription turntable must have performance figures of better than 0.1 per cent RMS for wow, 0.04 per cent RMS flutter and  $-40\text{dB}$  relative to  $1\text{cm/sec}$  at  $1\text{kHz}$  for rumble. This represents a very high standard, which is at least twice as good as that acceptable for the popular type of record playing unit.

There cannot be such a thing as a perfect turntable; for example, spindles do not rotate without some degree of friction, however small. This in turn produces heat and noise. Whereas in such an application as a turntable spindle bearing, the bearing temperature rise is almost unmeasurable, any noise generated can be amplified and reproduced as rumble during the playing of a record. Bearing friction can also vary and cause wow and flutter in the reproduced sound. Recognising the fact that wow, flutter and rumble must always be present to some degree, the major problem both in the design and manufacture of a transcription turntable is to keep them to the practical minimum.

When considering the design of a transcription turntable, even assuming that the performance required can be attained, the objective is to make sure that the performance will be maintained throughout long periods of continuous use, possibly running into years. The turntable must also be able to withstand the rigours of transport and, for export requirements, use in conditions of high temperature and humidity.

Fortunately cost is not an overriding factor when designing a turntable of this calibre, the attainment and maintenance of a high performance being the principal criterion.

To meet the conditions required the complete turntable assembly must be mechanically robust, whilst at

the same time manufactured to a high standard of precision engineering. The Garrard Model 401 transcription turntable (figure 1) is considered to be one of the best examples in this class and some of the problems in its design and manufacture will now be described.

One of the most important items in a transcription turntable is the actual turntable on which the record is placed, and although the majority of commercial record playing units use a turntable pressed from sheet steel, this method of construction is insufficiently accurate for transcription purposes. Additional weight is also an advantage in improving stability and constancy of speed. For this reason, the turntable of the Garrard Model 401 is an aluminium gravity casting weighing approximately 6lb after machining. Aluminium was chosen for this purpose because of its non-magnetic properties; it will not interfere with any sensitive magnetic pickup which may be used in conjunction with it. In addition, aluminium is a stable metal and it is readily machinable, and the gravity casting process which is employed in the production of the initial blank produces a casting which is almost free from porosity or blow holes. The ultimate turntable is, therefore, a reasonably homogeneous mass requiring a minimum of attention in order to achieve near perfect balance, providing that the machining operations are carefully controlled.

Much thought has been given to the planning of the various machining operations of the Model 401 turntable, in order to maintain perfect accuracy and performance.

The casting is held in a chuck on its outer diameter, and the inside surface including the inside rim, is rough turned. At the same time a hole is bored in the hub, and a brass bush is pressed into this hole. The casting is then reversed in the chuck and held on the rough turned inside rim while the largest diameter and the top surface are machined. During this operation a small raised rim is left at the periphery. This rim will provide a location for the rubber mat on which the record is placed and in this way the true running of the rubber mat is assured, and a good appearance maintained. The turntable is then again reversed in the chuck and is held on the turned outside diameter while the inside rim, which constitutes the driving surface, is carefully machined, and in the same operation, the taper hole is accurately bored in the centre brass bush. The taper of the bore has an included angle of 4 degrees which must correspond exactly with the tapered section of the spindle on which it will fit, for the slightest mis-



Figure 1. Model 401 transcription turntable

matching of the two tapers will cause a rock in the turntable during running, with a consequent increase in rumble and possibly wow.

At this stage, the stroboscopic markings are made on the periphery of the turntable, and here again, absolute accuracy is essential, for the slightest variation in the spacing of the stroboscopic bars will present a false impression of unsteadiness. In order to achieve this accuracy the bars are gear cut on a Sykes gear shaper which not only ensures an absolute regularity of spacing, but also presents a very pleasant instrument-like appearance when completed.

As the Model 401 transcription turntable is used in all parts of the world, it is necessary to provide stroboscopic markings for either fifty or sixty hertz power supplies, and whereas for sixty hertz it is possible to cut all three markings in one operation, for fifty hertz two operations are necessary, due to the number of bars not having a common factor.

After the stroboscopic cutting operation, the outer rim of the turntable is sprayed with a matt black enamel. The top surfaces of the bars are then skimmed in a lathe in order to expose the bright aluminium which, against the dark matt background of the recesses, provides the required contrast to obtain clear visual stroboscopic indication of the speed when the turntable rim is illuminated by the built-in neon lamp. Finally, the turntable is statically balanced by drilling recesses on the underside of the rim in appropriate positions to correct any out-of-balance which may be caused by variations in the density of the metal casting.

To ensure stability, the whole turntable assembly comprising the electric motor, turntable spindle housing and ancillary components is assembled to a substantial base plate. This plate is an aluminium diecasting well ribbed to prevent distortion. The location for the turntable spindle housing is machined so that the spindle, when assembled, is square with the base plate. This makes sure that the turntable and top face of the base plate are parallel. After final machining the plate is stove enamelled an attractive shade of dark grey and the chrome trims fitted.

The performance of the whole unit mainly depends upon the accuracy of the turntable spindle assembly which, therefore, requires special attention. The spindle is machined from a high grade of steel which is then hardened, tempered, ground, lapped and super-finished, the turntable location being tapered to correspond exactly with the bore in the turntable.

As the spindle carries the whole weight of the turntable, a special thrust bearing was designed. The bottom face of the spindle is lapped almost to a mirror finish and this runs upon an oil retaining sintered bronze disc, which is slightly convex on the underside so that it can move, ensuring that its flat, top face makes intimate contact with the lapped face on the bottom of the spindle. The convex face of this sintered disc rests upon a pad of plastic material in the base of the housing to provide a certain amount of vertical resilience which assists in reducing rumble (figure 2).

The bearings in the turntable spindle housing are also of oil retaining sintered bronze and are broached to size after being pressed into machined locations in the housing. This accurately aligns and sizes the

bearings. The lower bearing has its own lubrication duct accessible by removing a screw on top of the housing. This duct is necessary as the small tolerance may not allow sufficient oil to seep through the top bearing to lubricate the lower one.

The four-pole induction motor used for driving the turntable is basically similar to that in general use on high quality record playing units, but has the addition of a relatively heavy cast iron casing to provide magnetic screening; the mass of the iron casing helps to reduce vibration which is inherent in all a.c. electric motors. The motor assembly is isolated from the base plate by six tension springs, the motor being held in suspension between them. The springs are anchored in a cradle attached to the base plate. This provides an effective vibration barrier between the motor and the rest of the unit. This form of motor suspension is used as it is not subject to deterioration.

With a transcription turntable of the class of the Model 401, it must be possible to vary the nominal speed of the turntable by a small amount so that when required, the correct pitch may be obtained when playing records of musical instruments, and to enable programmes to be precisely timed in broadcasting studios.

This speed control is also used to correct any slight variation from the nominal speed which may occur through the unit being connected to a supply voltage at the maximum or minimum limits of its range.

On the Model 401, provision is made to vary all three of the turntable speeds by plus or minus 3 per cent. This is achieved by means of an eddy current brake applying a load to the motor shaft. The speed of an induction motor of the type used for sound reproducing equipment is dependent upon a constant load; if the load varies so does the speed. Fortunately, the load when driving a gramophone turntable—especially when using modern lightweight pickups—varies so little that, providing the initial speed is correct, the resulting variations can be ignored. To obtain a controlled speed variation two methods are in general use. One is to keep the speed of the motor constant and vary the ratio of the drive between the motor and turntable, the other is to vary the speed of the motor keeping the drive ratio constant.

Altering the drive ratio is usually achieved by means of tapered pulleys and adjusting the vertical position of the rubber intermediate wheel. This method can lead to "scrubbing", caused by the edge of one side of the intermediate wheel being driven or driving on a slightly different diameter of the tapered pulley than its opposite edge. This can produce uneven wear on the wheel resulting eventually in speed instability.

The method used on the Model 401 is to vary the speed of the motor by regulating the load applied to it with an eddy current brake (figure 3).

Attached to the motor shaft is an aluminium disc across which the poles of a permanent magnet can be traversed. The position of this magnet can be varied across the radius of the disc by means of the speed variation control knob on the top of the base plate. There are several advantages with this system. The load is constant because no mechanical brake—and con-

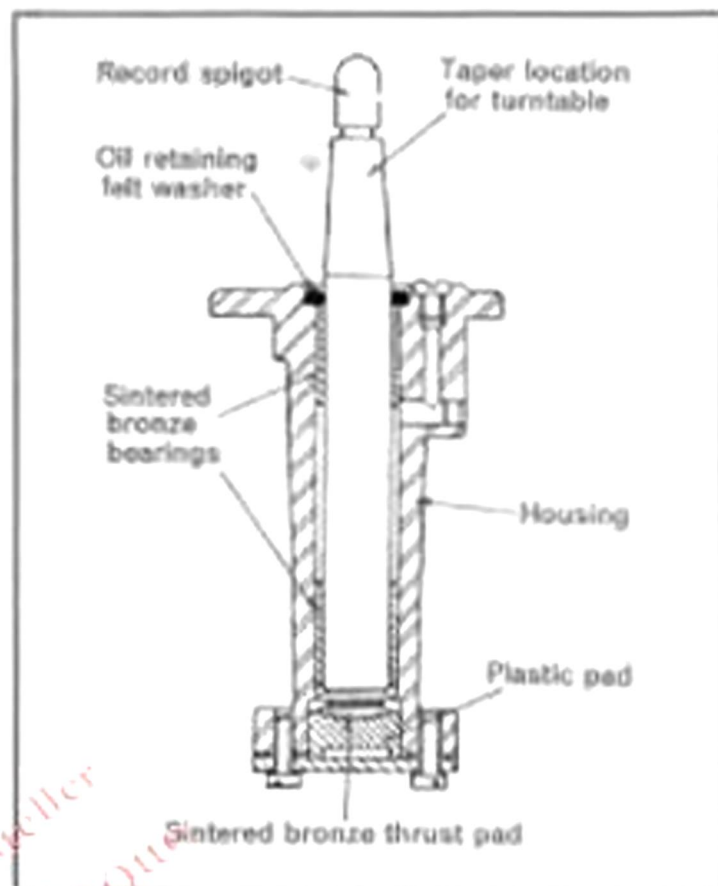

Figure 2. Section of turntable spindle bearing assembly

sequent friction—is involved, and the eddy current braking effect on the aluminium disc passing between the poles of the magnet occurs only when the disc is rotating so the motor will quickly start when switched on. When the magnet is clear of the disc its effect is slight, its maximum effect being when it is fully over the outer edge.

A double-pole switch is used for the power supply to the motor, and to avoid electrical interference which can be caused by the slight arc which occurs when breaking the switch contacts, each pole has a suppressor network connected across it. The switch assembly is located underneath the base plate, which serves as a screen to prevent electrical interference from the switch (and its wiring) inducing hum when sensitive magnetic pickups are used.

A high intensity neon lamp is fitted to illuminate the stroboscopic marking on the rim of the turntable, the beam of light from the lens in the end of the lamp being reflected from under the base plate on to the turntable by a small angular mirror.

Three basic speeds are provided 33½, 45 and 78 rev/min. 33½ and 45 rev/min are the ones in common use, but for broadcasting studios 78 rev/min is also required for playing the occasional 78 rev/min record. To prevent possible damage to the rubber intermediate wheel, which drives the turntable from the motor, the basic speed of the turntable can be changed only when the motor switch is in the "off" position, this is achieved by means of a mechanical interlock.

Operating the "on"—"off" control to switch off

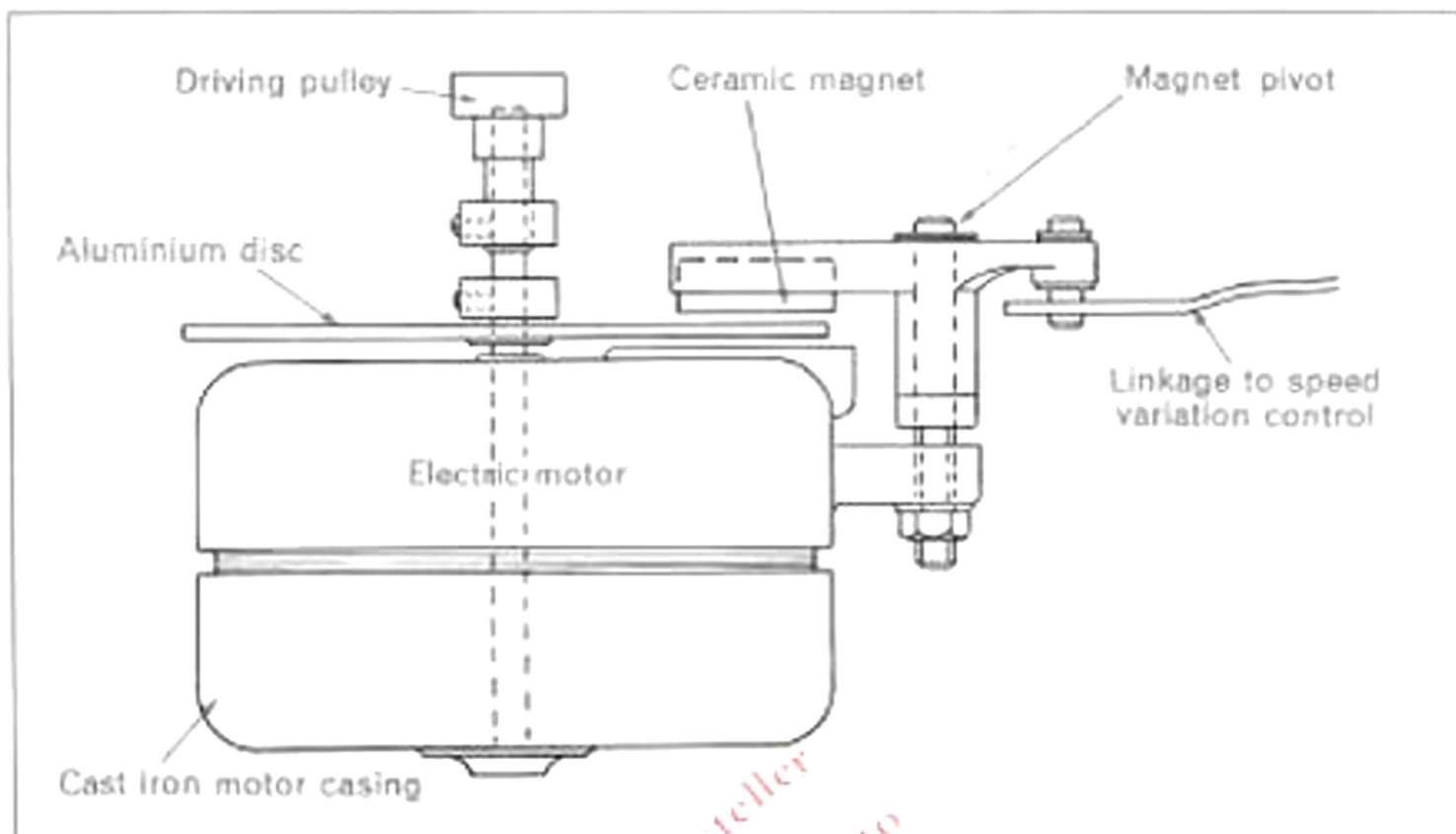

Figure 3. Eddy current brake for speed regulation

removes the intermediate drive wheel from contact with the motor pulley and inside rim of the turntable and at the same time applies a brake to the turntable. Retracting the rubber intermediate wheel in this way prevents surface indentation when it is stationary while the brake is required to reduce free rotation of the turntable which, without a brake, could, on 78rev/min be as much as twenty revolutions after switching off.

The mat on the top face of the turntable is moulded from electrically conducting rubber which helps to neutralise the static electrical charge on a record while it is lying on the mat. This does not permanently remove the static as the record resumes its charge on removal from the mat, but in neutralising the static it does prevent the attraction of dust particles from several feet away while the record is on the turntable for playing; it also facilitates cleaning the record on the turntable.

Component parts for the Model 401 are processed through the factory in much the same way as those for other record playing units, but are subjected to a specially rigorous inspection to make sure the closer tolerances on this unit are maintained. The tolerances between the various spindles and shafts are extremely small so that after selective assembly the turntable must be run for at least twenty-four hours before the shafts are free enough for the unit to be tested. Each complete turntable is visually inspected, then aurally checked in a soundproof booth for mechanical noise. Having successfully passed these preliminary checks, the turntable is then mounted on a special fixture designed to isolate it from all sources of external

vibration. This fixture consists of a steel framework loaded with heavy concrete blocks suspended in a cradle by four tension springs, the mounting board for the turntable under test standing on the concrete blocks (figure 4).

This procedure is necessary as the rumble from the turntable to be measured is so small that a greater amount could be transmitted through the floor due to passing traffic or by machines on the factory floor some distance away; without some form of isolation these vibrations could be mistaken as being generated by the turntable.

Wow and flutter are assessed by measuring the deviation in frequency of a 3,000Hz signal reproduced from a record played on the turntable under test. A repetitive rate of deviation above 20Hz is shown as flutter, whilst below this figure it is shown as wow.

Wow and flutter are normally given as RMS values but some authorities now quote peak values which are higher; this point should be noted when making comparisons of published specifications.

Rumble is unwanted background noise reproduced while playing a record, and it normally occurs within the range of frequencies between 20 and 500Hz but is only really significant up to 200Hz. To measure the rumble content of a turntable a special test record is played using a pickup and amplifier of known characteristics. A reference frequency band on the record is played and the meters on the measuring instrument are set to a calibrated level. Filters are then switched in to cut out all frequencies above 200Hz. A band of un-

recorded groove is then played. The voltage output from the pickup under these conditions is then shown as rumble. For a high quality turntable such as the Model 401 the frequency range is split into four bands, 20 to 50, 51 to 90, 91 to 140, and 141 to 200Hz; this is largely to facilitate the identification of the source of rumble should the figure shown be above the set limit. For example, too high a figure in the 20 to 50Hz band would indicate that the motor was most likely to be the cause, the speed of the rotor being such as to produce vibrations of 22.5Hz. This could be due to the rotor being outside the limits for balance or the driving pulley being out of true, or loose. A peak in the 91 to 140Hz band could indicate excessive hum from the motor being shown up at 100Hz. The meters for measuring the output from the four bands can be seen on the instrument in figure 4.

For quality control purposes the whole frequency spectrum covering rumble is plotted on a level recorder and a typical curve is shown in figure 5.

Other tests check that the time taken for the turntable to reach its nominal speed after switching on is within limits; that after running for ten minutes the speed is stable; that the percentage of variation above and below the nominal speed is not excessive; also that the current consumption of the motor is within limits over the two ranges of 110/130 and 220/250V. Finally the whole assembly is given an insulation test between windings and frame.

Due to the close bearing tolerances the grade of lubricating oil used is rather critical. Too thick an oil in the turntable spindle bearing could stop the turntable, or at best increase the time taken for the turntable to attain its speed after switching on. In view of this a

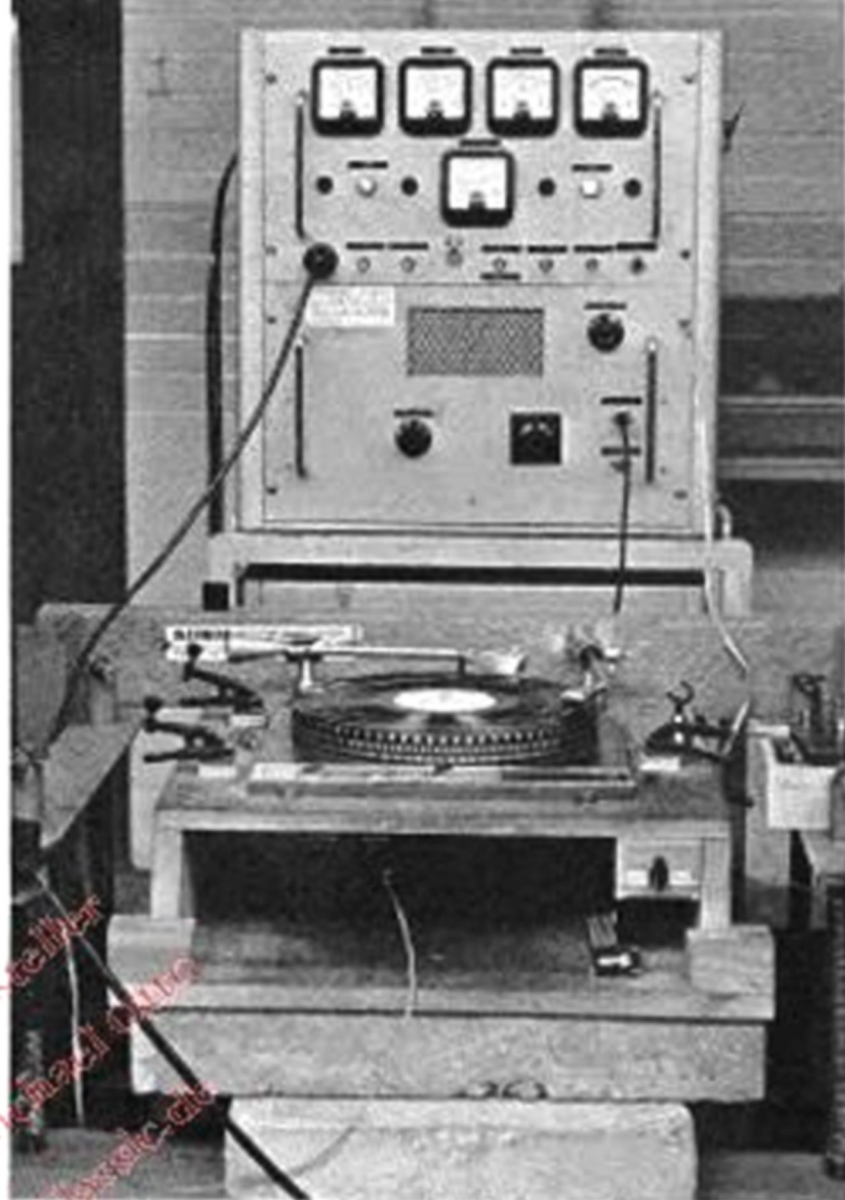
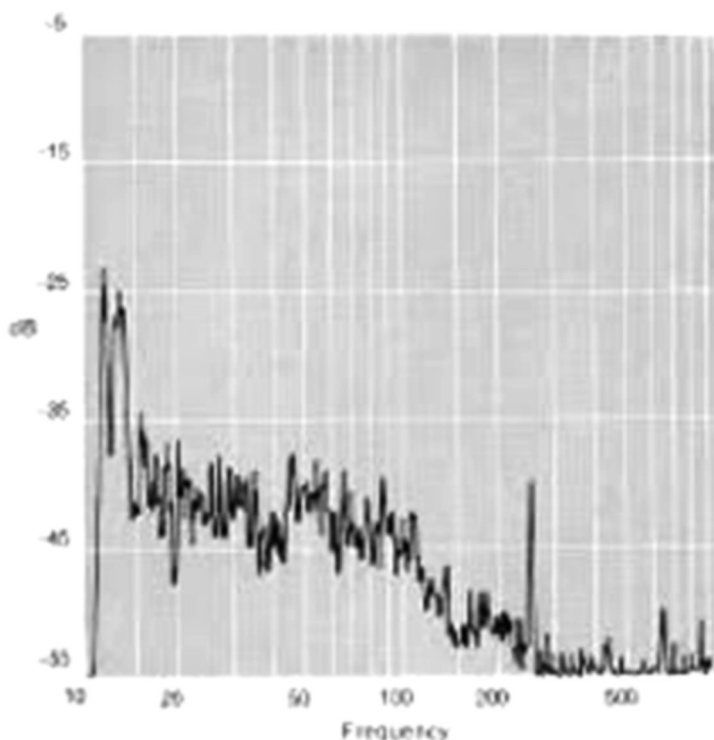

Figure 4. Instrument panel and suspended platform used for testing transcription turntables

Figure 5. Typical curve showing rumble levels



supply of the recommended lubricating oil is supplied with each unit. For accurate work, such as is needed for programme timing, it is recommended that the turntable be switched on and allowed to run for at least ten minutes to allow the motor and turntable bearings to attain their running freeness. However, in most studios the motor is hardly ever switched off, the turntable being left running continuously and used as required.

As the motor in its cast iron casing is relatively heavy, provision is made to clamp it rigidly in the cradle to prevent possible damage during transit by its movement on the spring suspensions. This is done by means of two screws, which are readily accessible from the top of the unit after removal of the turntable. It is important that the clamping screws are released when the unit is installed, or at any time prior to playing if the motor has been re-clamped for transit.

The reputation of the Garrard Model 401 transcription turntable is based not only upon its own merits, but also upon that of its predecessor the Model 301 which in principle and mechanical design was similar. The Model 301 was in production for over ten years and many of the original units are still in use in studios throughout the world.

KN202