

RM 765/780/865

REFERENCE MONITOR SYSTEMS

- The first 6½" and 8" Coaxial Reference Monitors
- Phase and Time Coherent – Point Source
- Uniform Flat Response Across Expanded Dynamic Range
- Uniform Flat Response in Both 2 TT and 4 TT Environments
- Extended Bass Response -865 with 10" woofers



NEAR-FIELD MONITORS

The typical placement of speakers in the typical room results in a confusion of sound. You end up hearing a lot of the room colorations and reflections mixed in with the direct source. Sure, you can spend even more money and equalize the room. Even then you may have to invest in an outboard crossover in order to compensate for the loudspeaker design. Avoid all these problems with Fostex Near-Field Monitors. They are Point Source, coaxial speakers. All the sound emanates from a point reference, just like in nature, so all the sound reaches your ears at the same time. Stereo imaging is rock solid. This design produces a "sweet spot" so you know that what you're hearing from the RM Series will sound proportionally the same in a car, on a hi-fi system or through a custom-tuned playback system in the studio.

An unusually low crossover point gives you another important benefit not found in conventional designs: vital midband information like vocals will not be modulated by high-mix, low-frequency sounds like kick drums. The same RP patented driver gives you uniformly flat high frequency response in all three models; the woofers increase from 6.5 inches to 8 inches to 10 inches. The two drivers in the RM 765 are the identical elements in the RM 865 3-way system, which simply adds a 10-inch woofer. This larger system is also ready for bi-amplification. In our listening tests with 800W - 1000W per side, these beauties have generated 115 dB SPL at the console with no audible distortion. The Near-Field Monitors from Fostex give you clarity and punch and definition – as loud as you need it.



THE INITIAL REFERENCE

RP stands for Regulated Phase. It's a new transducer technology which has been under development at Fostex for the last ten years. So far, more than 20 international patents have been awarded.

The first products with the RP Technology were headphones. The idea worked so well, the inventors immediately began applying it to the reciprocal transducer, the microphone.

A whole series of microphones now exists with the same basic principles embodied in the new RM 765 and RM 780 tweeters. The essential idea of this RP Transducer is a flat, thin film diaphragm onto which the voice coil is printed; this assembly is then suspended between magnetic circuits arranged on both side of the diaphragm, with the same polarities facing each other and the opposite polarities adjacent to one another.

The end result of this arrangement permits the diaphragm to be driven with absolute uniformity. Which means it doesn't sound differently at different levels. It provides the same uniform frequency response across an extremely wide dynamic range.



It won't break up, either. Which means there won't be the usual high frequency distortion to mask the over-use of 12 kHz boost, for example.

Because the printed film diaphragm moves identically in both directions, and the entire diaphragm surface is within the magnetic field, it by-passes all of the response variations caused by conventional mounting designs. There simply is no mechanically induced distortion in the RP tweeter. It functions as an edgeless device.

In this sense, the double spider design of the RM-Series woofers is the perfect complement to the RP tweeter. In a conventional single spider design, the compliance from one direction differs from the other. This difference produces unacceptable distortion, particularly in the second harmonic region. Fostex engineers added a second spider in a push/pull complementary configuration to cancel the compliance effects of a single spider design. The result is a 10 dB improvement in second harmonic distortion. A 2" voice coil/magnet assembly and a computer modeled bass reflex design complete the profile of what is definitive low end response in the Reference Monitor Series.

THE POINT SOURCE REFERENCE

These two exceptional drivers are first placed in a coaxial relationship, then time compensation adjusted in a true concentric design. So all the music arrives at your ears simultaneously, not unlike the natural phenomena of sound.



Both drivers are now phase coherent and time coherent. They now produce a point source reference so clear and well-defined that the experience approaches the theoretic ideal of a pulsating sphere. It's hard to imagine another close field monitor coming anywhere near the overall performance of the Fostex RM. Harder still would be to find one with uniform frequency response in both 2 TT and 4 TT environments.

Most small reference monitors like the 765 and 780 are designed for rack, wall or soffit mounting (2 TT). Unlike the others, ours have a switch for free field or console mounting (4 TT).

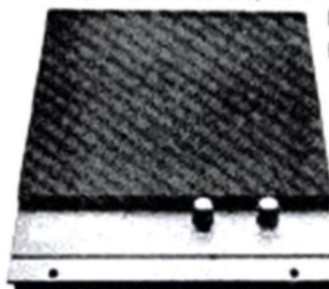

Regardless of the placement, the Fostex 765s and 780s may be switched (front panel, of course) for proper response. And because they are phase and time coherent, you can mount them vertically or horizontally. Rack adaptors and mounting hardware are available, and all holes have been pre-drilled for convenient interface with any standard rack. The problems of placement have been anticipated so that you can get on with using them.

THE FINAL REFERENCE

With all the attention digital audio has been receiving for some time, it's important to remember that transducers will still be at the first and final points of any audio chain for a long time yet.

At Fostex, a quiet, ten year development of a new transducer technology has come full cycle. From headphones to microphones and now to monitors. The new Reference Monitor Systems from Fostex. Patented RP tweeter. Double Spider woofer. Coaxial with both Phase and Time Coherence for true, concentric point-source reference. Selectable 2 TT and 4 TT fields.

The rest of the information in this brochure is in the form of graphs and charts, specifications and other technical data. This kind of documentation is useful, even necessary in some applications. But the final truth about these monitors, like all monitors, is subjective. It's in the hearing, your final reference.

When you audition the RM Series, please listen Near-Field Monitors. That's the way these remarkable speaker systems were designed to operate. They avoid the typical problems of room coloration and the Point Source design gives you a rock solid basis for stereo imaging.

The RM 765 and 780 are 2-way systems with 6.5-inch and 8-inch woofers, respectively. The RM 865 is a 3-way system with the RM 765 drivers and a 10-inch woofer, ready for bi-amplification.

They all give you a reference which will translate accurately to other playback systems. So if you work with sound, work with the Fostex Near-Field Monitors. The RM Series with patented RP Technology.

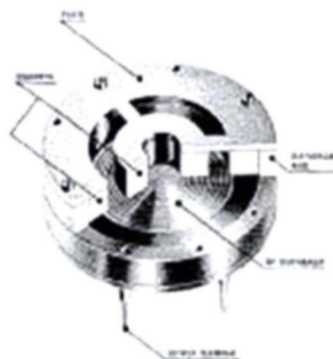

1. The Development and Design of a Flat Diaphragm, Printed Ribbon Microphone Capsule, by S. Hoshino, Japan, presented at the 12th Convention of the Audio Engineering Society, October, 1992.

RM765

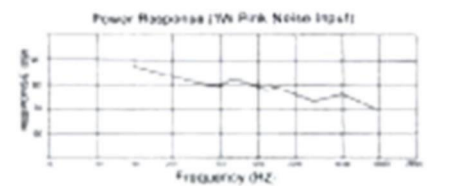
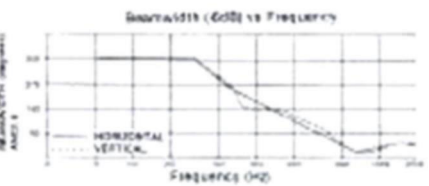
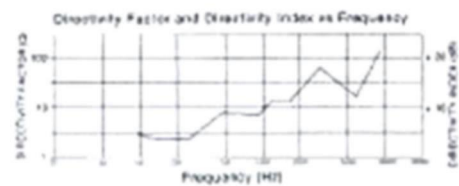
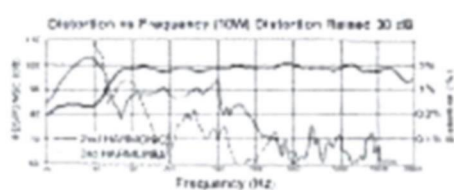
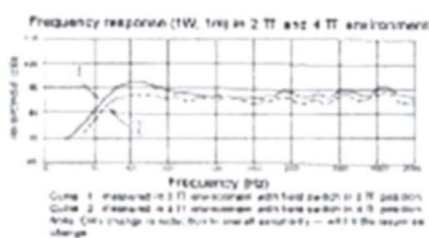
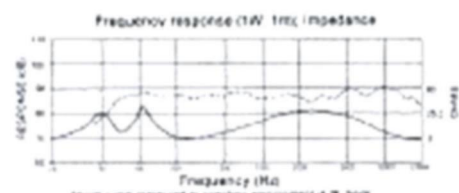

RM780

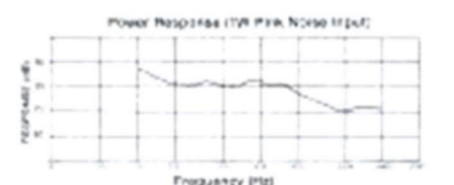
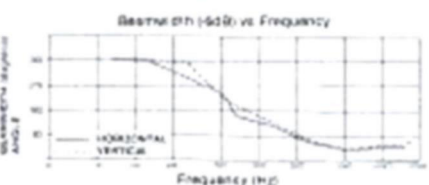
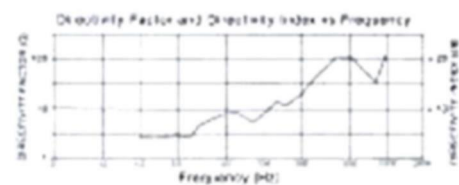
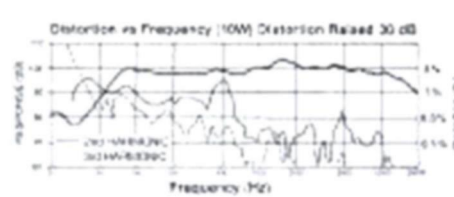
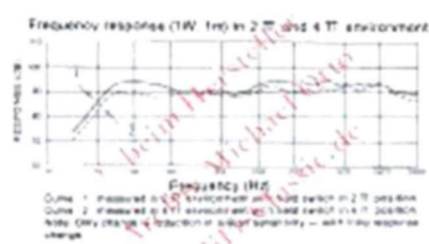
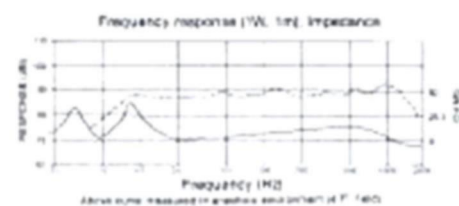

RM865

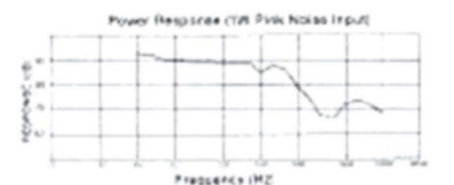
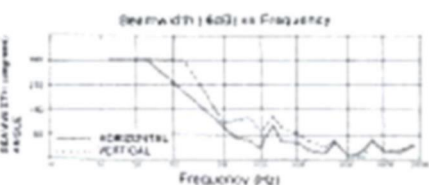
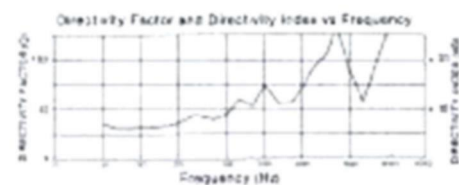
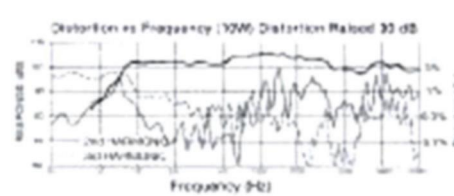
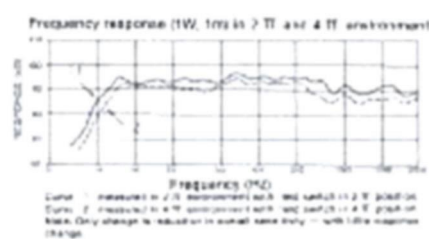
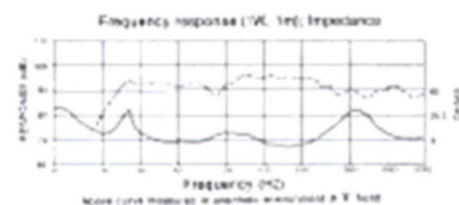

Polar Response

RM 765

RM 780

RM 865

HORIZONTAL

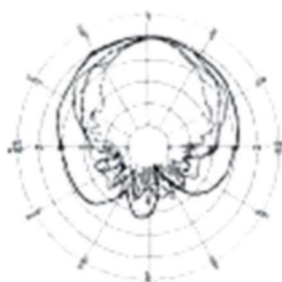
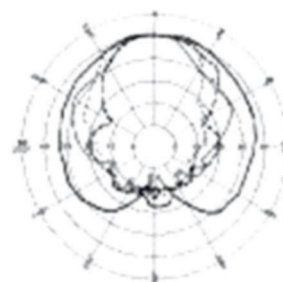
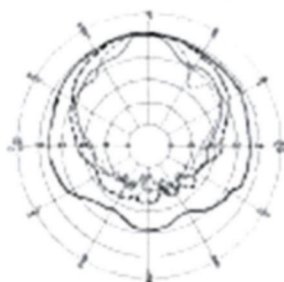

630Hz
2.5kHz
6.3kHz
10kHz

VERTICAL

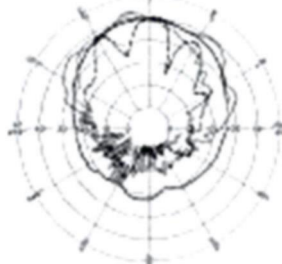
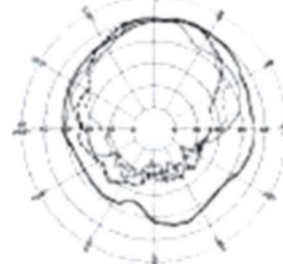
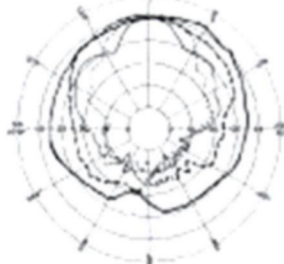

SPECIFICATIONS

Enclosure Type:
Power Capacity:

Frequency response:
(2 TT or 4 TT)

Sensitivity: (1W, 1m)

Reference efficiency:
2 TT
4 TT

Distortion: (10W)

Nominal impedance

Minimum impedance

Controls:

Cabinet finish

Dimensions (H x W x D)

inches

mm

Net weight

Lbs

Kg

RM765

Vented reflex
120 watts continuous
program power
60 watts continuous pink
noise
70 Hz to 20 kHz \pm 3dB

91dB
88dB

0.70 %
(1.4 %)
less than 2 % 2nd harmonic
less than 1 % 3rd harmonic
(from 70Hz-20kHz)

8 ohms
6.5 ohms
Field control
High frequency level
Mat resistant matte

15 x 8 5/8 x 8 5/8
380 x 220 x 220

14.1
6.4

RM780

Vented reflex
150 watts continuous
program power
75 watts continuous pink
noise
58 Hz to 20 kHz \pm 3dB

90dB
90dB

1.25 %
(1.6 %)
less than 2 % 2nd harmonic
less than 1 % 3rd harmonic
(from 58Hz-20kHz)

8 ohms
6.5 ohms
Field control
High frequency level
Mat resistant matte

17 x 10 3/8 x 10 5/8
430 x 264 x 270

18.7
8.5

RM865

Vented reflex
150 watts continuous
program power
75 watts continuous pink
noise
50 Hz to 20 kHz \pm 3dB

94dB
91dB

1.58 %
0.79 %
less than 2 % 2nd harmonic
less than 1 % 3rd harmonic
(from 50Hz-20kHz)

8 ohms
6 ohms
Field control
High frequency level
Mat resistant matte

23 5/8 x 13 x 12 5/8
600 x 330 x 320

45
20.5

Mounting/Placement

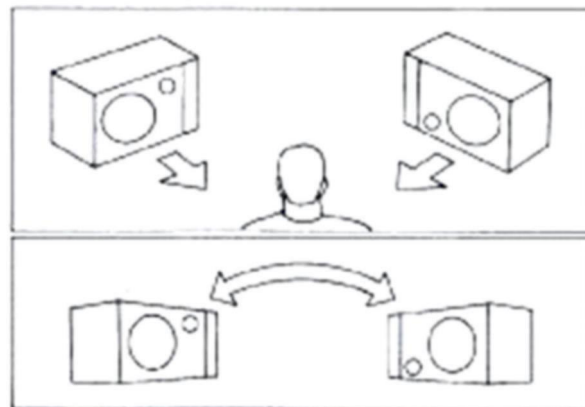

The RM-765s and RM-780s are designed to operate within 3 to 4 feet of the listener for best imaging and spatial information. The RM-865s can also be used in the direct listening field, and since they generate higher listening levels, they can also operate as a ceiling mounted Main Monitor system.

As the RM series uses co-axial drivers, placement is very easy. First, the distance from the listener to the speakers should be 1 to 2 times the distance the co-axial speakers are spread apart. Second, due to the controlled dispersion of these monitors, place the tweeters in the co-axial driver so they are "aimed" at the listener. Again, due to the co-axial driver design, the monitors can be placed horizontally, vertically or a combination of the two with no effect on the imaging. Also, the monitors, by design, are mirror-imaged pairs so they can be placed with drivers out, or drivers in when used horizontally.

Following these simple rules will ensure you are always in the "sweet spot" and obtain the maximum performance from your FOSTEX REFERENCE MONITORS.

Fostex
Pro Sound Division

FOSTEX CORPORATION (60-3 MIYAZAWA-CHO AKOISHIMA TOKYO, JAPAN 196 TELEPHONE 0425-45-6111 TELEX: 2642 212 FOSTEX J FAX 0425-46-3199
FOSTEX CORPORATION OF AMERICA 15431 BLACKBURN AVE., NORWALK, CA 90650 U.S.A. TELEPHONE (714) 925-1112 TELEX 576698

Specifications subject to change without notice.

0530820701 © AUG. 1985 FOSTEX Printed in Japan.