

# Service Manual

# THE FISHER®

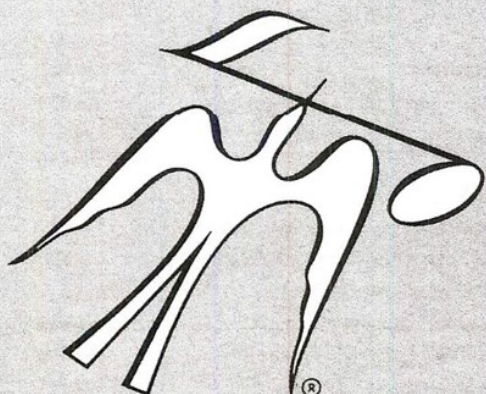

# X-202-C

CHASSIS SERIAL NUMBERS  
BEGINNING 10000

\$1.00

FISHER RADIO CORPORATION • LONG ISLAND CITY 1 • NEW YORK

# PARTS DESCRIPTION LIST

## CAPACITORS

10% tolerance for all fixed capacitors, unless otherwise noted or marked GMV (guaranteed minimum value).  
All capacitors not marked uF are pF (uF).

Symbol	Description	Part No.	Symbol	Description	Part No.
C1, 2	Ceramic, 30, N150, 1000V	C50070-3	C27	Electrolytic, 2 section: A — 200uF, 250V B — 40uF, 450V	C50180-19
C3, 4	Ceramic, .01uF, 20%, 500V	C50089-3			
C5, 6	Mylar, .047uF, 400V	C50197-30	C28	Electrolytic, 3 section: A — 40uF, 475V B — 40uF, 475V C — 20uF, 300V	C50180-75
C7, 8	Ceramic, 470, 1000V	C50072-13			
C9, 10	Ceramic, 1000, 1000V	C50072-3			
C11, 12	Mylar, .022uF, 400V	C50574-8			
C13, 14	Mylar, .047uF, 400V	C50197-30	C29	Electrolytic, 2 section: A — 1000uF, 35V B — 1000uF, 35V	C50180-37 AX
C15, 16	Ceramic, 33, N750, 1000V	C50070-15			
C17, 18	Ceramic, .05uF, +80—20%, 100V	C50073-2	C30	Electrolytic, 50uF, 35V	C50483-4
C19, 20	Ceramic, 560, 1000V	C50072-14	C31, 32	Ceramic, 5, NPO, 1000V	C50070-24
C21, 22	Mylar, .047uF, 630V	C50197-101	C33, 34	Ceramic, 21, 5%, NPO, 1000V	C50070-32
C23, 24	Mylar, .047uF, 400V	C50197-30	C35	Molded, .01uF, 20%, 600V	C2747
C25	Molded, .01uF, 20%, 600V	C2747			
C26	Electrolytic, 200uF, 250V	C50180-20			

## RESISTORS AND POTENTIOMETERS

Deposited Carbon, in ohms, 5% tolerance, 1/3-watt, unless otherwise noted. K=Kilohms, M=Megohms.

Symbol	Description	Part No.	Symbol	Description	Part No.
R1, 2	100K, 1/8 W	R12DC104J	R53, 54	56K	R33DC563J
R3, 4	100K, 1/8 W	R12DC104J	R55, 56	330K, 1/8 W	R12DC334J
R5, 6	560K	R33DC564J	R57, 58	68K, 1/8 W	R12DC683J
R7, 8	10K	R33DC103J	R59, 60	68K, 1/8 W	R12DC683J
R9, 10	100K	R33DC104J	R61, 62	330K, 1/8 W	R12DC334J
R11, 12	Glass, 330K, 5%, 1W	R30G334J	R63, 64	1K, 1/8 W	R12DC102J
R13, 14	Glass, 2.7K, 5%, 1/2 W	R20G272J	R65, 66	1K, 1/8 W	R12DC102J
R15, 16	4.7M	R33DC475J	R67, 68	Composition, 330, 10%, 1W	RC30BF331K
R17, 18	220K	R33DC224J	R69	Wirewound, 1.5K, 10%, 7W	RPG7W152K
R19, 20	330K, 1/8 W	R12DC334J	R70	Composition, 2.7K, 10%, 1W	RC30BF272K
R21, 22	47K, 1/8 W	R12DC473J	R71	Composition, 8.2K, 10%, 1W	RC30BF822K
R23, 24	Composition, 10M, 10%, 1/2 W	RC20BF106K	R72	Composition, 47K, 10%, 1W	RC30BF473K
R25, 26	2.7M	R33DC275J	R73	Composition, 150K, 10%, 1W	RC30BF154K
R27, 28	150K	R33DC154J	R74	Wirewound, 15, 10%, 5W	R719-106
R29, 30	1.5K	R33DC152J	R75	4.7K	R33DC472J
R31, 32	1M	R33DC105J	R76	22K	R33DC223J
R33, 34	82K	R33DC823J	R77 A, B	Potentiometer, 250K, Aux Level	R50150-12
R35, 36	2.2K	R33DC222J	R78 A, B	Potentiometer, 250K, Phono Level	R50150-12
R37, 38	22K	R33DC223J	R79 A, B	Potentiometer, 500K, Dual, Bass	R50160B153
R39, 40	10K, 1/8 W	R12DC103J	R80 A, B	Potentiometer, 500K, Dual, Treble	R50160B153
R41, 42	470K	R33DC474J	R81 A, B	Potentiometer, 500K, Dual, Volume	R50160B143
R43, 44	1.2K	R33DC122J	R82 A, B	Potentiometer, 500K, Dual, Balance	R50160B152
R45, 46	220, 1/8 W	R12DC221J	R83, 84	Potentiometer, 25K, D.C. Balance	R50103-2
R47, 48	1.2K, 1/8 W	R12DC122J	R85 A, B	Potentiometer, 25K, Phase Inverter	R50150-14
R49, 50	330K	R33DC334J	R86, 87	Composition, 12, 10%, 1/2 W	RC20BF120K
R51, 52	39K	R33DC393J	R88, 89	Composition, 220, 10%, 1/2 W	RC20BF221K

## MISCELLANEOUS

Symbol	Description	Part No.	Symbol	Description	Part No.
CR1, 2	Silicon Diode D600	SR50411-1	S10	Switch, Power	Part of R81
CR3, 4	Silicon Diode	SR 50472	T1	Transformer, Output (Left)	T1158-116-1
F1	Fuse, 3.2 Amp., Slo-Blow	F3319	T2	Transformer, Output (Right)	T1158-116-2
I1	Lamp, Pilot No. 18470F	I50009-8	T3	Transformer, Power	T1158-115
PC1, 2	Printed Circuit, Equalization	PC50187-3	—	Insert, Dress Panel Screened (Upper)	AS1158-122
PC3, 4	Printed Circuit, Hi Filter	PC50187-19	—	Insert, Dress Panel Screened (Lower)	AS1158-123
PC5, 6	Printed Circuit, Tone Control	PC50187-9	—	Knob, Selector, Mode, Balance	E50562-1
S1	Switch, Selector	S1158-120	—	Knob, Dual, Top, Tone Control	E50563
S2	Switch, Mode	S1113-117	—	Knob, Dual, Bottom, Tone Control	E50564
S3 to 8	Switch, Rocker	S50200-15-1	—	Knob, Volume	E50566-1
S9	Switch, Impedance Selector	S1158-125			

# COMPONENT CONNECTIONS

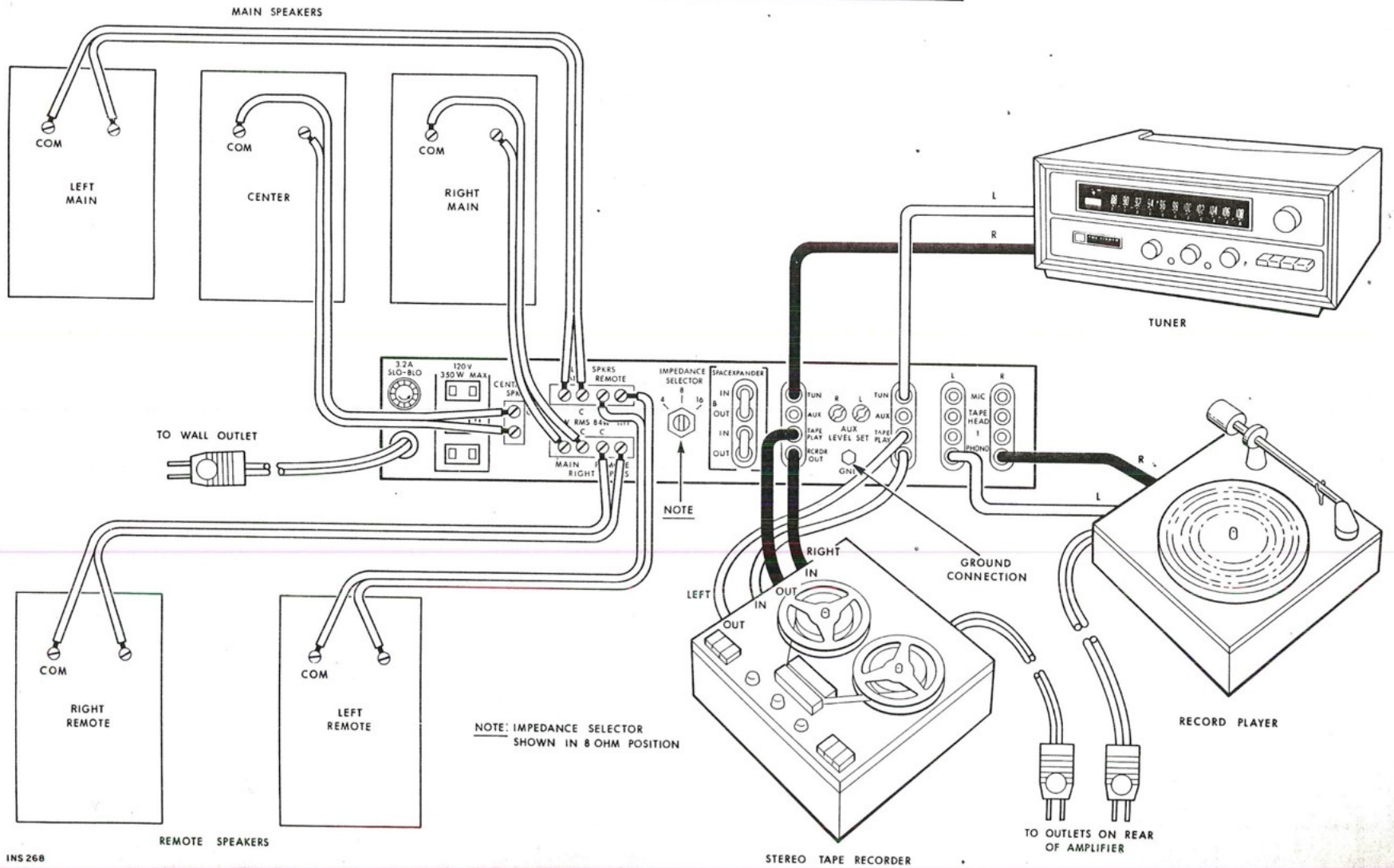

# TUBE LAYOUT

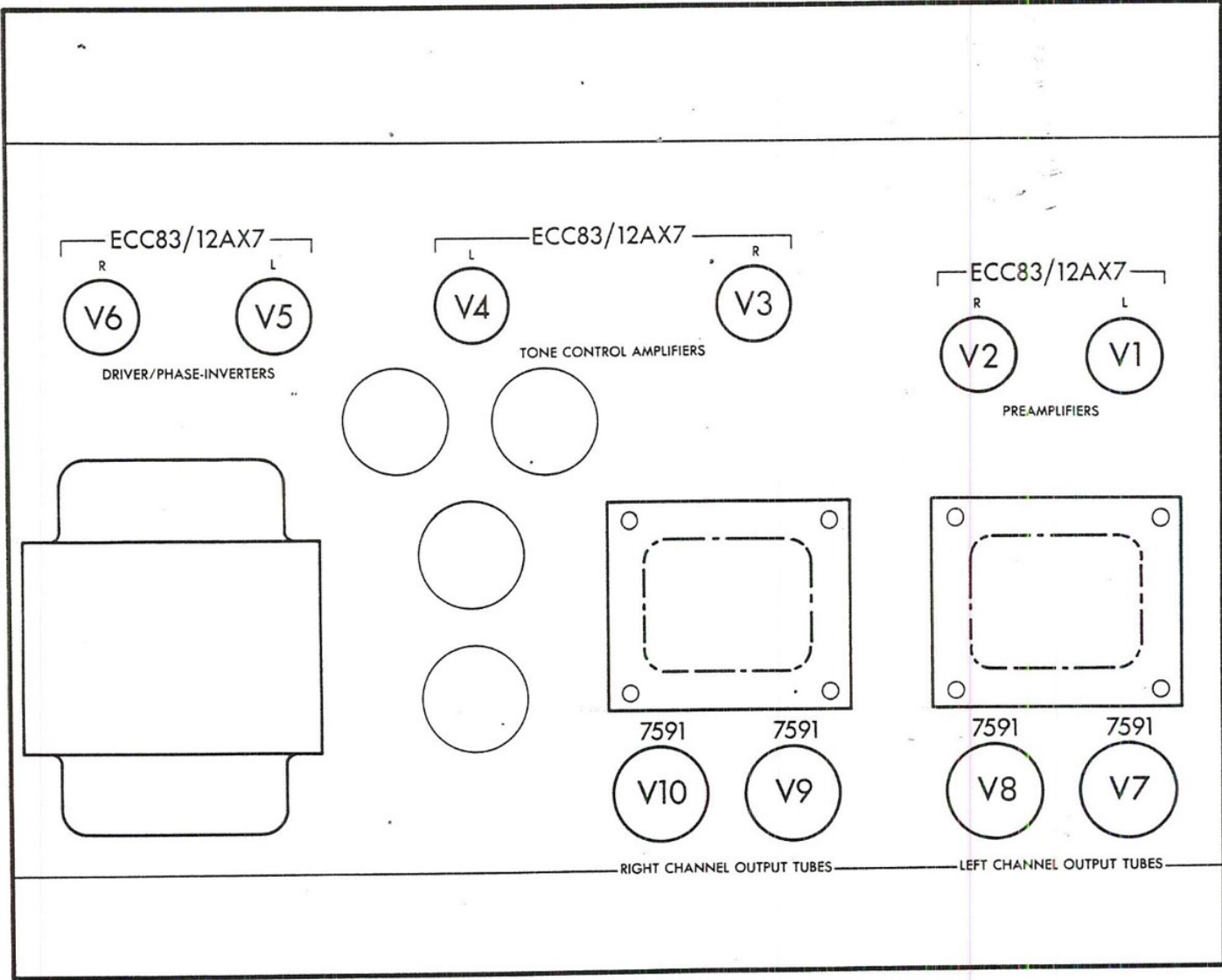

**FISHER RADIO CORPORATION • NEW YORK**



# ALIGNMENT INSTRUCTIONS

**Equipment Required:** Audio (AC) VTVM  
IM (Intermodulation Distortion) analyzer  
4-ohm, non-inductive load resistor  
(minimum rating of 50 watts)

## Phase Inverter Adjustment

**IMPORTANT:** Note (on the schematic) that the C (common) speaker terminals are **not** at ground potential. **The 4-ohm taps of the output transformer are grounded.** Never ground the C terminals directly (or accidentally) through the interconnected ground leads of the test equipment.

**Main Speaker** switch (front panel) must be put in its **on** position.

**Impedance** switch (rear panel) must be set to 4.

## Channel A

- Connect a 4-ohm load between C and left Main-speaker terminals.
- Connect IM analyzer output to TUN input of channel A.
- Connect the analyzer-input ground lead to the left Main-speaker terminal.
- Connect the analyzer-input "hot" lead to the left Main-speaker C terminal.
- Set the SELECTOR switch to TUN ; the MODE switch to STEREO. Adjust the analyzer for 9.6 VAC across the 4-ohm load resistor.
- Adjust the CH A phase-inverter control for minimum IM distortion.
- Adjust the CH A DC-balance control for minimum IM distortion.
- Repeat the last two steps several times for lowest possible IM distortion.

## Channel B

- Connect a 4-ohm load between C and right Main-speaker terminals.
- Connect IM analyzer output to TUN input of channel B.
- Connect the analyzer-input ground lead to the right Main-speaker terminal.
- Connect the analyzer-input "hot" lead to the right Main-speaker C terminal.
- Set the SELECTOR switch to TUN ; the MODE switch to STEREO. Adjust the analyzer-output control for 9.6 VAC across the 4-ohm load.
- Adjust the CH B phase-inverter control for minimum IM distortion.
- Adjust Channel B DC-balance control for minimum IM distortion.
- Repeat the last two steps several times for lowest possible IM distortion.

# SCHEMATIC DIAGRAM

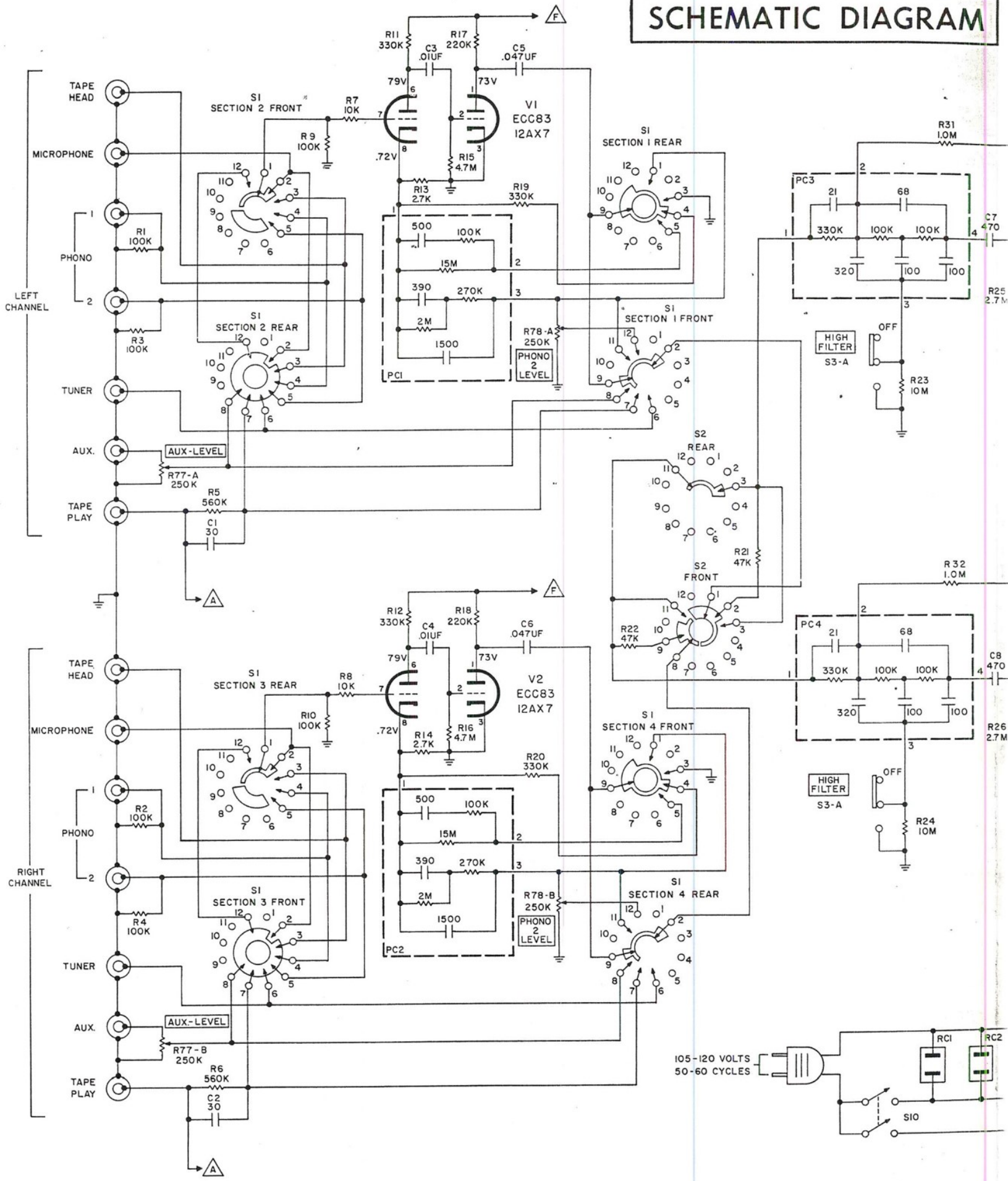

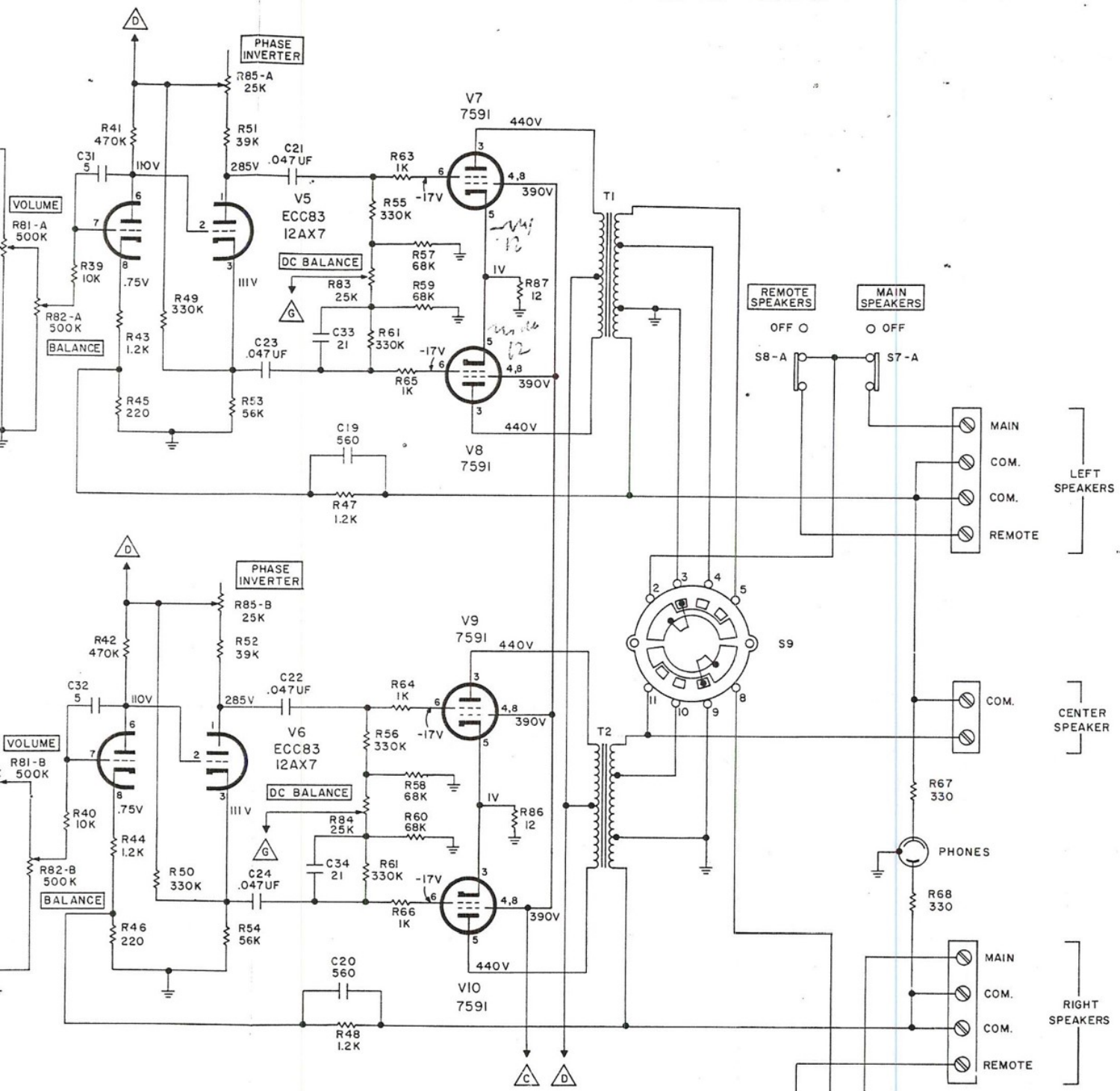

SWITCH POSITIONS		
S1 SELECTOR SWITCH	S2 MODE SWITCH	S9 IMPEDANCE SWITCH
MIC (SHOWN)	MONO (SHOWN)	4 (SHOWN)
TAPE HEAD	STEREO	8
PHONO 1	REVERSE	16
PHONO 2		
TUNER		
TAPE PLAY		
AUX.		

**NOTES:**

- 1 - ALL VOLTAGES MEASURED AT 117 V.A.C. LINE, WITH NO SIGNAL INPUT.
- 2 - PHONO 2 LEVEL CONTROLS ARE LOCATED BEHIND THE FISHER NAMEPLATE WHICH MUST BE PULLED OUT FOR ACCESS.
- 3 - AUX. LEVEL CONTROLS ARE LOCATED ON THE REAR PANEL.

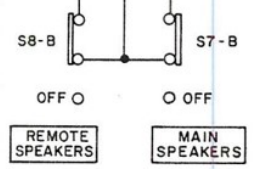



# FISHER SERVICE TIPS

## X-202-C CONTROL AMPLIFIER

SYMPTOM: Erratic operation when connected to external accessories such as record players and tape recorders.

Insufficient ventilation may result in heat buildup around the 7591 output tubes. This heat can affect the insulation of the audio cables which are dressed beneath the output tube sockets. Excessive heat destroys the insulation around the inner conductor of these audio cables resulting in obscure short circuits between the inner and outer conductors of the cable.

When servicing X-202-C amplifiers, remove the bottom and rear chassis covers and using an ohmmeter, check each cable for shorts by flexing the wires. Replace damaged cables before performing any other servicing.

Upon returning the unit to the customer, caution the owner to leave a minimum of 2 inches of unobstructed space on all three sides of the unit and 4 inches above the tops of the output tubes as directed by the Operating Instructions which accompanied the unit.

10/4/66



FISHER RADIO CORPORATION  
LONG ISLAND CITY 1, NEW YORK