

FISHER
FISHER
FISHER
FISHER
FISHER
FISHER
FISHER
FISHER



FISHER

Studio-Standard

OPERATING INSTRUCTIONS

RS-2010

STEREO RECEIVER

FISHER
FISHER
FISHER
FISHER
FISHER
FISHER
FISHER
FISHER
FISHER
FISHER ...
FISHER

THE FIRST NAME IN HIGH FIDELITY

NOTE: Locate receiver's serial number (shown on rear panel of unit) and record it here  _____



SPECIFICATIONS

POWER AMPLIFIER SECTION

Continuous RMS sine wave power per channel within stated bandwidth at no more than stated distortion and with 8 ohm load		100 Watts
Power Bandwidth		20 Hz – 20 kHz
Total Harmonic Distortion at rated power		0.03 %
I.M. Distortion		0.03 %
Speaker Damping		> 40

PREAMPLIFIER SECTION

Frequency Response		
Phono (30 Hz – 15 kHz)		±0.5 dB
Aux (20 Hz – 20 kHz)		±0.5 dB
Input Sensitivity and Impedance		
Phono 1, 2		2 mV/50 kΩ
Tape Monitor 1, 2		150 mV/100 kΩ
Auxiliary		150 mV/100 kΩ
Output Voltage and Impedance		
Tape Out (Rated Output)		150 mV/5 kΩ
Graphic Equalizer		
50 Hz		±10 dB
250 Hz		±10 dB
1 kHz		±10 dB
4.5 kHz		±10 dB
15 kHz		±10 dB
Filters		
Subsonic at 10 Hz (18 dB/Oct.)		-10 dB
Loudness Contour (100 Hz/10 kHz)		+8 dB/+4 dB
Hum and Noise (IHF A Weighted, Inputs Shorted)		
Phono 1, 2		76 dB
Aux/Tape Monitor 1, 2		90 dB

FM TUNER SECTION

Usable Sensitivity		
Mono		1.7 μV/9.8 dBf
Stereo		4.3 μV/17.9 dBf
50 dB Quieting Sensitivity		
Mono		2.5 μV/13.2 dBf
Stereo		34 μV/35.9 dBf
Signal-to-Noise Ratio		
Mono/Stereo		75/70 dB
Capture Ratio		0.8 dB
Alt. Channel Selectivity (±400 kHz)		80 dB
Image Response Ratio		90 dB
Spurious Response Ratio		100 dB
IF Response Ratio		100 dB
AM Suppression Ratio		65 dB
Total Harmonic Distortion at 65 dBf		
Mono/Stereo		0.1/0.2 %
T.H.D. at 50 dB Quieting Sensitivity		
Mono/Stereo		0.3/0.4 %
Stereo Separation (100 Hz/1 kHz/10 kHz)		40/50/40 dB
Sub-Carrier Product Rejection (19/38 kHz)		65/70 dB
Audio Frequency Response (20 Hz – 15 kHz)		±0.5 dB

AM TUNER SECTION

Usable Sensitivity	300 μV/m
Selectivity (±10 kHz)	40 dB
Signal-to-Noise Ratio	55 dB
Image Response Ratio	50 dB
IF Response Ratio	45 dB

GENERAL

Power Requirements (50/60 Hz)	120 V AC ±10 % 400 W/500 VA
AC Outlets	2
Dimensions WxDxH	20-5/16" x 14-1/4" x 6-11/16"
Weight	36 lbs.

* Specifications are subject to change without notice.

ANTENNA CONNECTIONS

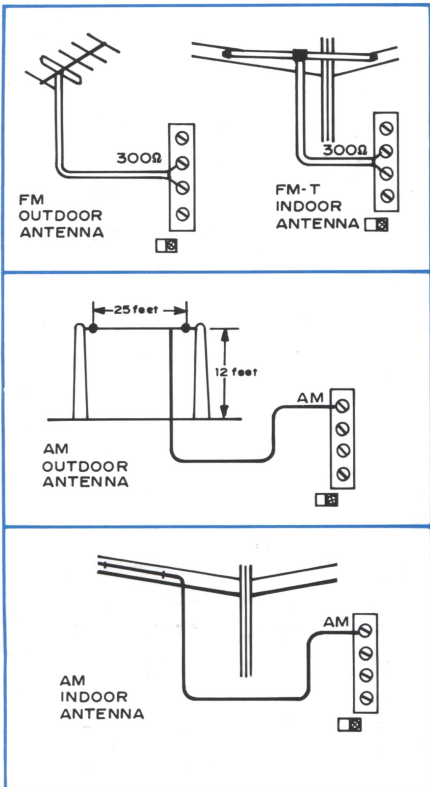

While installation is relatively simple, certain precautions must be taken. **RANTY DOES NOT COVER DAMAGE CAUSED BY MISHANDLING OR INSUFFICIENT VENTILATION.** We therefore urge you to follow the following instructions:

CAUTION: If you are not sure whether your speakers can safely handle the power, do not turn the receiver's VOLUME control up too high. FAILURE TO DO SO MAY PERMANENTLY DAMAGE YOUR SPEAKERS!

WARNING: TO PREVENT FIRE OR SHOCK HAZARD, DO NOT OPEN THE RECEIVER CASE.

5 Swing the AM ferrite antenna away from the receiver chassis as far as it will go without forcing it. Keep all speaker, audio, and power cables away from this antenna and never use it as a handle.

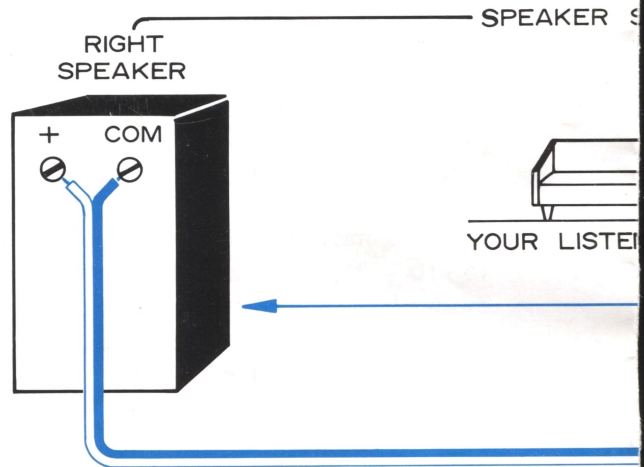

CONNECTION OF 75 OHM SHIELDED CABLE FROM FM ANTENNA.

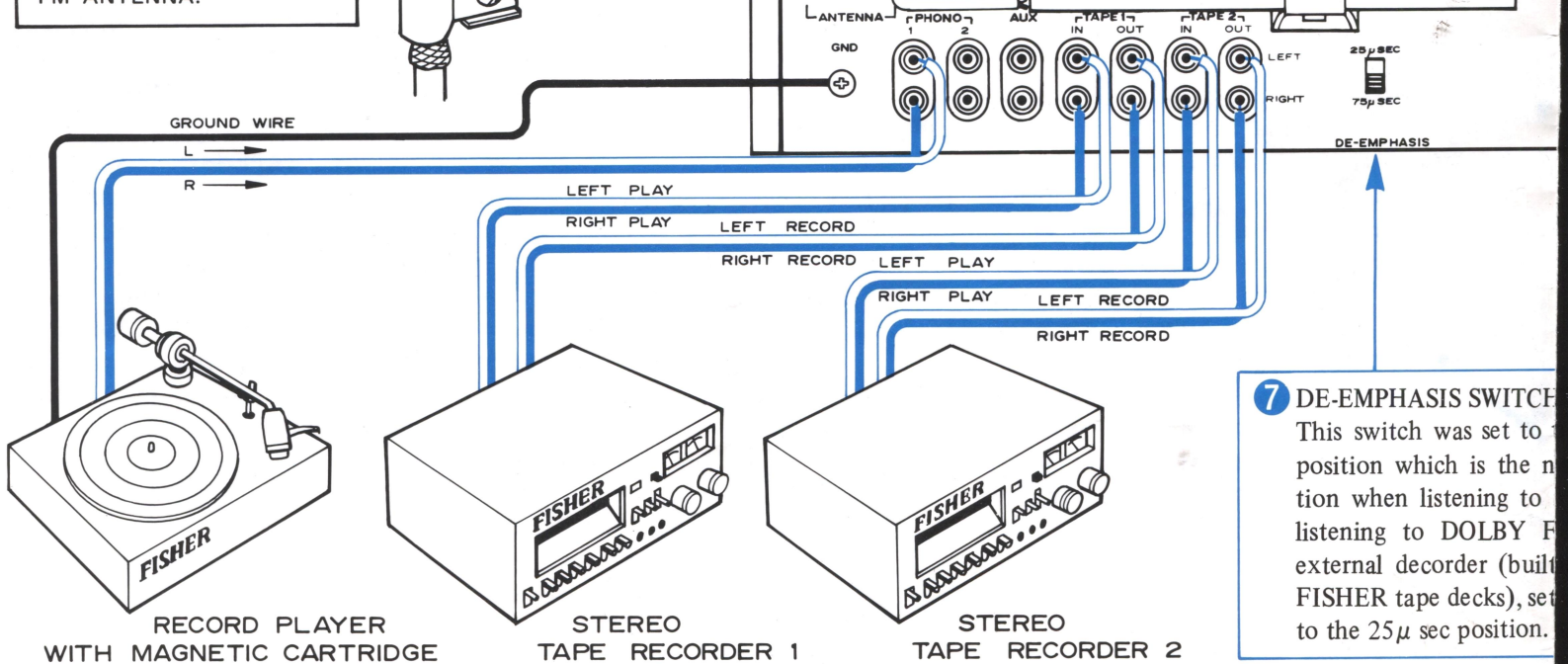
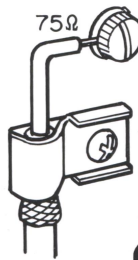

7 DE-EMPHASIS SWITCH: This switch was set to the 25 μ sec position which is the normal position when listening to standard music. When listening to DOLBY B external decoder (built into FISHER tape decks), set the switch to the 75 μ sec position.

observed. PLEASE KEEP IN MIND THAT OUR WARNING, MISUSE, EXCESSIVE LINE VOLTAGE, OR the instructions in this section carefully and in sequence.

handle the maximum audio-power output of your receiver, BE SURE TO OBSERVE THIS PRECAUTION MAY PER-

DO NOT EXPOSE THIS APPLIANCE TO RAIN OR MOISTURE.

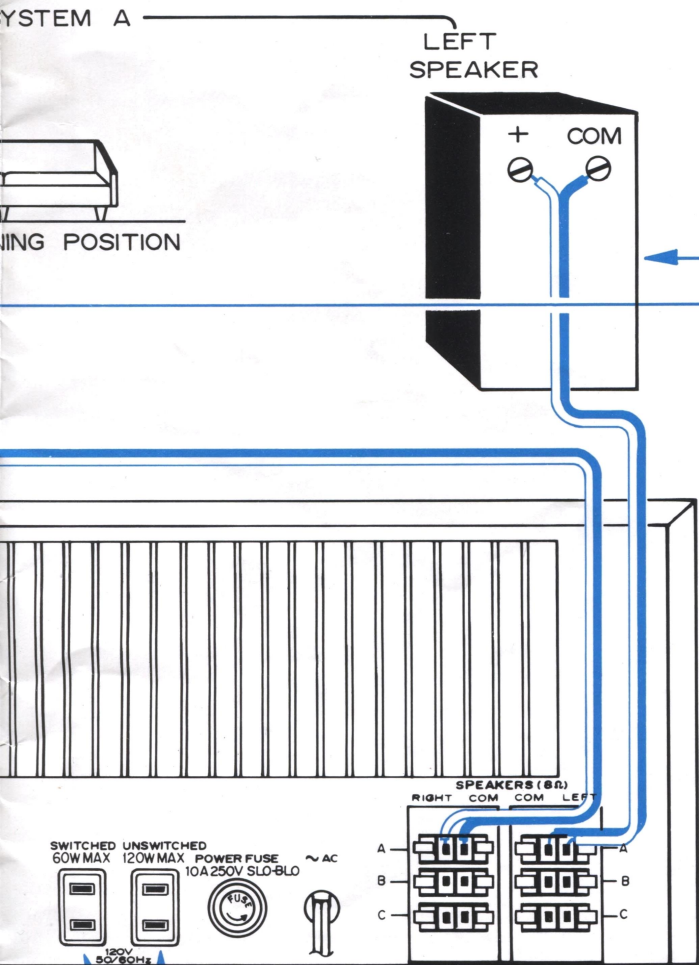

Fig. 1

4 Place your two speakers 5 to 10 feet apart, facing your selected listening position, and as close as possible to ear level. Connect both speakers exactly as shown (each speaker's terminal to its corresponding terminal on the set). Make sure that the bare wires at the ends of the cables do not touch each other, adjacent terminals, or the receiver's chassis.

NOTE:

The receiver's SPEAKERS terminals are quick-connect alligator-jaw types. Simply push back the top tab on each terminal, slip the bare wire into the opening of the terminal, and release the tab to grip the bare wire in the jaws.

START HERE

1 Make sure that local electric power is AC, and that the voltage matches the voltage specified on the rear of the receiver (or, in some cases, on a special tag on the power cord).

CAUTION:

Read the instructions on this page before connecting the power cord to an electrical outlet.

2 Place the receiver on any convenient shelf or table away from all sources of heat. Allow at least 2 inches clearance above and behind the receiver for ventilation.

3 Unwind the power cord completely, drape it full length, and plug it into an AC wall outlet.

6 AC OUTLET (SWITCHED)

Controlled by the power switch, this outlet is capable of delivering up to 60 W of AC power. Use this outlet as the power supply for a record player.

AC OUTLET (UNSWITCHED)

This outlet is live irrespective of the position of the power switch and delivers up to 120 W of AC power. Use this outlet as the power supply for a tape recorder.

the 75µ sec normal position. When used with an FM tuner, this switch

This section describes the receiver's controls in the order in which you will use them in a step-by-step sequence. You will master complete operation of the unit.

- 1 POWER Switch**
Press in the POWER button to switch on the set. Release the button to switch off the set. Do not worry if you hear a slight "thump" during switch-on or switch-off; this is perfectly normal and will not damage any part of your system.
- 2 FUNCTION Switch**
Select the program source you want to hear (except a tape recorder or deck, covered in step 18):
 - AUX – To play other sources of program material, such as a sound movie projector, tape cartridge player, TV set, or short wave tuner through the receiver.
 - AM – To listen to AM broadcasts.
 - FM – To listen to FM broadcasts.
 - PHONO 1 – To listen to phonograph records, if you have connected a record player to the PHONO 1 jacks.
 - PHONO 2 – To listen to phonograph records, if you have connected a record player to the PHONO 2 jacks.
- 3 PANEL LOGIC display**
The panel logic display is a visual readout panel which indicates continuously the selected receiver functions, the operating mode, the selected speaker system or systems, and the position selected with the tape monitor switch.

- 4 VOLUME & BALANCE Controls**
Initially, adjust the VOLUME control for a low listening level. After selecting a program source, adjust the control for the desired volume level.
Keep the BALANCE control at its mid-position unless the volume levels in the left and right channels sound unequal at your listening position. In such a case, turn the control either towards LEFT or RIGHT to restore balance.
- 5 GRAPHIC EQUALIZER Controls**
This FISHER Studio Standard RS-2010 receiver is equipped with a newly developed GRAPHIC EQUALIZER. The possibilities of altering the sound to your liking with the FISHER GRAPHIC EQUALIZER are endless. It places at your fingertips five controls, each controlling a separate section of the audio frequency range.
The advantage of the FISHER GRAPHIC EQUALIZER over conventional tone controls is that with each of the five controls of the GRAPHIC EQUALIZER it is possible to control five different narrow, distinct sections of the audio band pass by up to ± 10 dB. This corresponds to a power increase of 10 times or a power decrease to 1/10, whereas with tone controls a setting for a bass or treble boost or cut will also affect the lower or upper mid frequencies.

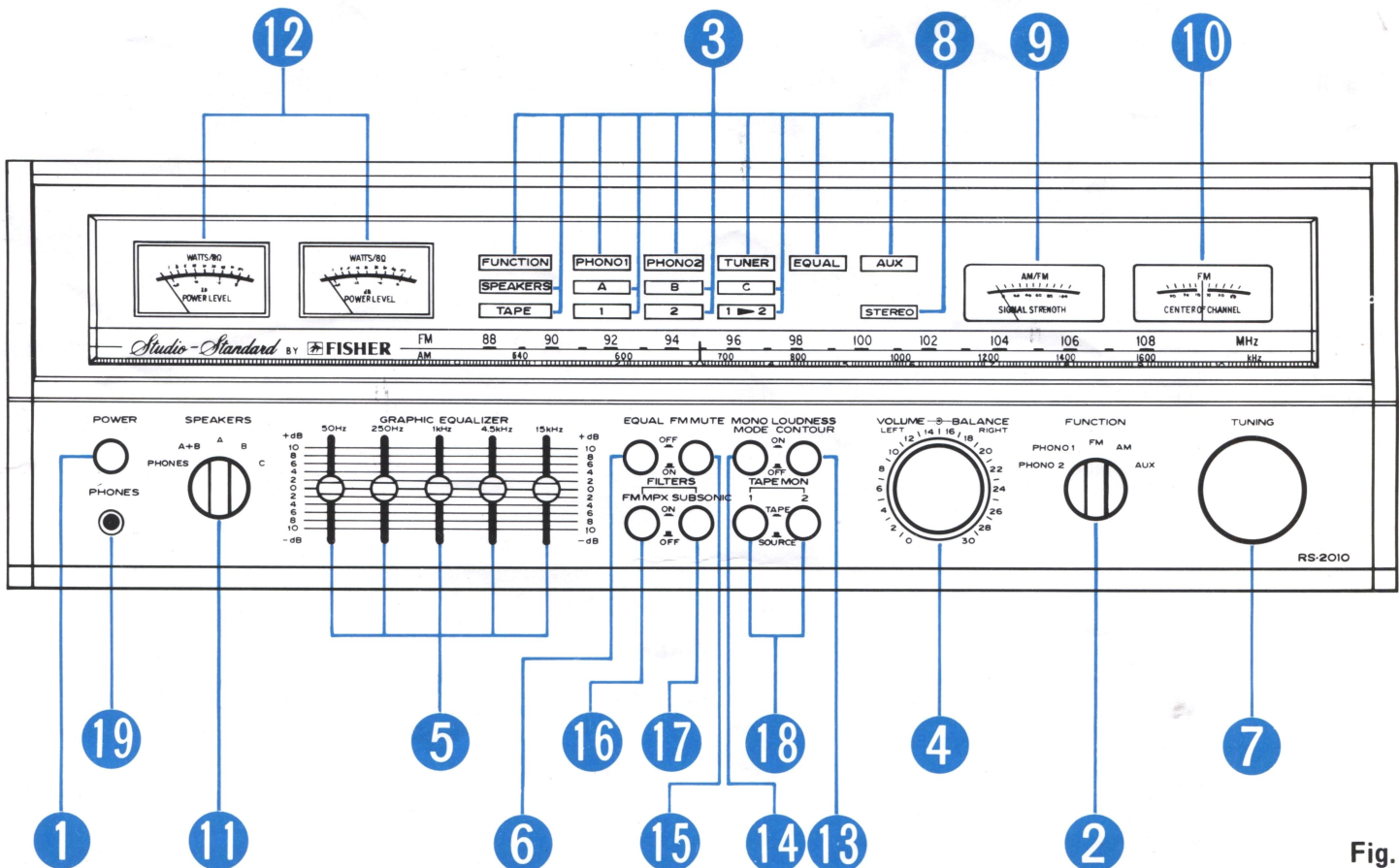

Fig. 2

RECEIVER

in which you would normally use them. Follow the instructions on the back of the unit in a very short time.

The frequency bands controlled by the five slide controls with stepped detents have been chosen to yield the maximum possible control action within the audio spectrum.

50 Hz — The 50 Hz control is very useful in enhancing low bass notes as in organ music, and it also offers the possibility to make corrections when a deficiency in bass exists, caused either by a listening room with poor acoustic properties like bass absorbing curtains, carpets and furniture, or by a component part of your system like a speaker, cartridge or record with a poor bass response.

250 Hz — The 250 Hz control will allow you to vary the upper bass frequencies.

1 kHz — The 1 kHz control is the presence control and can be used very effectively to emphasize, bring out front, or de-emphasize vocalists.

4.5 kHz — The 4.5 kHz control will add brilliance and clarity to brass instruments and violins.

15 kHz — The 15 kHz control can be used to make up for missing high frequencies absorbed by the environment and to add a natural crispness to music.

6 EQUAL Switch

In the OFF position, the GRAPHIC EQUALIZER controls are disconnected and a perfectly flat frequency response is obtained. Set it to the ON position, to bring GRAPHIC EQUALIZER controls into operation.

7 TUNING Knob

If you have selected FM or AM in step 2, tune in the desired station.

8 FM STEREO Indicator

With the FUNCTION switch in the FM position, the indicator will light when an FM stereo broadcast is received. If the indicator does not light during the reception of an FM stereo program, this indicates insufficient signal strength. Flashing of the indicator is due to spurious interference. Neither phenomenon indicates any problem with the unit.

9 SIGNAL-STRENGTH Meter

Maximum deflection of the meter pointer indicates that an AM or FM station is tuned in with optimum accuracy.

10 CENTER-OF-CHANNEL Meter

Turn the tuning knob and observe first the pointer of the signal-strength meter for maximum deflection to the right. Then turn the tuning knob very slowly until the pointer of the CENTER-OF-CHANNEL meter is in the center of the scale within the gap.

11 SPEAKERS Switch

Set the SPEAKERS switch to A or B or C or A+B positions, depending on the rear terminals to which your speaker system is connected. Use the PHONES position when you intentionally want to turn off your speakers (to listen privately through headphones, or to silence the music system momentarily, etc.).

12 POWER Meters

The power meters indicate the approximate music program power output levels delivered to the speaker systems.

The power meters may also be used for continuous system monitoring where they provide an instantaneous indication of left and right channel power distribution and channel balance.

13 LOUDNESS CONTOUR Switch

Set this button to the ON or OFF position as desired. Pressing it to the ON position will restore tonal balance and brilliance at normal and lower volume levels.

14 MONO MODE Switch

The only times you will have to press the MONO MODE button are:

- When listening to the occasional FM stereo broadcast that sounds noisy and causes erratic STEREO Light blinking with the MONO MODE button out.
- When playing a mono auxiliary source or mono record through the receiver.

15 FM MUTE Switch

Keep this button in the ON position to silence between-station noise and weak, noisy FM stations. Push this button in, to the OFF position only when you wish to listen to such stations.

16 FM MPX FILTER Switch

Push this button in, to the ON position to reduce noise interference during FM stereo program reception.

17 SUBSONIC FILTER Switch

Push this button in, to the ON position only when playing old phonograph records which contain rumble, or when using a record player which produces low-frequency noise. At all other times this button should be set to the OFF position.

18 TAPE MONITOR Switches

Keep these buttons in the SOURCE position so that you do not accidentally silence any program source chosen with the FUNCTION switch. Push the TAPE MONITOR 1 button in, to the TAPE position only when you wish to play back or monitor tapes from a tape recorder or deck connected to the receiver's TAPE-1 IN jacks. Push the TAPE MONITOR 2 button in, to the TAPE position only when you wish to play back or monitor tapes from a tape recorder or deck connected to the receiver's TAPE-2 IN jacks. Push the TAPE MONITOR 1 button in, to the TAPE position and release the TAPE MONITOR 2 button out, to the SOURCE position when you wish to duplicate from a tape recorder or deck (in the playback mode) connected to the receiver's TAPE-1 jacks to a tape recorder or deck (in the recording mode) connected to the receiver's TAPE-2 jacks.

19 PHONES Jack

For private listening insert STEREO HEADPHONES. (See page 6 for details.)

TROUBLE-SHOOTING GUIDE

If you have followed the instructions in the INSTALLING and OPERATING sections, and have trouble operating your system, locate the SYMPTOM in the left column below. Check the corresponding POSSIBLE CAUSE and CORRECTIVE ACTION columns to locate and remedy the problem.

SYMPTOM	POSSIBLE CAUSE	CORRECTIVE ACTION
POWER switched ON but no sound and no light on Dial Scale.	Faulty AC power plug connection to wall outlet.	Examine plug. Old wall-outlets sometimes cause power loss. Plug must fit snugly in outlet.
	Receiver's POWER FUSE blown.	Replace receiver's POWER FUSE according to directions in the MAINTENANCE section.
Dial Scale lit but no sound (or very weak sound) from FM, AM, and PHONO.	TAPE MONITOR button pressed in.	Release TAPE MONITOR button. NOTE: Turn VOLUME control down to avoid damage to your loudspeakers.
	SPEAKERS switch set to PHONES.	Reset SPEAKERS switch to A or B or C or A+B. (See No. 11 on page 4)
Sound from one speaker only.	BALANCE control turned all the way to one side.	Reset BALANCE control to center position.
	Speaker wired incorrectly.	Check connections of speaker cables in the rear of the receiver and at the terminals on the back of each speaker. Check to see that no strands of wire connected to terminals on the receiver or speaker touch the chassis or any other terminal. Be sure wires are firmly secured to each terminal.
PHONO has loud hum with normal, little, or no audio. FM and AM are OK.	Faulty connection between record player and receiver.	Check and crimp outside (shell) of phono cable plugs.
Loud howling sound when recording with microphone on tape recorder.	TAPE MONITOR button pressed in.	Release TAPE MONITOR button. Press in TAPE MONITOR button only during playback from the recorder, or while monitoring from 3-head tape deck.
Poor FM reception.	No antenna connected.	Connect an FM antenna to the FM ANT. terminals at the rear of the receiver. Refer to the INSTALLING illustration and the ANTENNAS section.
	Shorted or faulty connection(s) between FM antenna and receiver.	Check connections of FM antenna leads at the rear of the receiver.
	Antenna not oriented for best reception.	Change position of (or rotate) antenna. Refer to the ANTENNAS section.
No FM STEREO stations received.	MONO MODE button pressed in.	Release MONO MODE button.

HEADPHONES AND REMOTE SPEAKERS

WARNING:

If you are not sure whether each of your remote speakers can safely handle the maximum audio-power output per channel of your receiver, do not turn your receiver's VOLUME control up too high.

FAILURE TO OBSERVE THIS PRECAUTION MAY PERMANENTLY DAMAGE YOUR SPEAKERS!

STEREO HEADPHONES

For private listening to all program sources, you may plug a pair of stereo headphones into the PHONES jack on the control panel. When using the headphones for the first time, turn the VOLUME control to MIN and set the SPEAKERS switch to PHONES before plugging in the phones.

Readjust the VOLUME control for comfortable headphone listening level and use this setting for future reference.

CAUTION:

Do not leave the headphones plugged in when playing the speakers at high volume levels. The large amounts of audio power required by the speakers at these levels can overload and damage the headphones.

STEREO REMOTE SPEAKERS

The receiver's B or C speaker terminals on the rear of the unit provide convenient means for connecting a pair of remote extension speakers. This arrangement will enable you to enjoy stereo sound in other rooms of your home whenever you set the SPEAKERS switch to B, C or A+B.

CAUTION:

Before connecting your B or C speakers, check their rated impedance and the impedance of your A speakers as well. If each speaker is rated at 8 or 16 ohms, you may safely connect your B or C speakers as described in the following instructions. In the rare event that the A or B speaker is rated at 4 ohms, have a technician add a 2-ohm, 10-watt resistor in series with that speaker. Failure to observe this precaution may cause overload and distortion when you play the A plus B speakers simultaneously at high volume levels. (Only in A+B position of the SPEAKERS switch.)

- 1) Turn off the receiver and disconnect its power cord from the electrical outlet.
- 2) Place your B or C speakers 5 to 10 feet apart, facing your listening position, and as close as possible to ear level. Connect both speakers exactly as shown in the illustration (each speaker's COM, GND, or black terminal to its corresponding COM terminal on the receiver). Use either the cables supplied with the speakers or, for distances up to 30 feet, No. 18 lamp cord or flat TV twin-lead. For longer distances, use heavy-duty cable (at least No. 16). Make sure that the bare wires at the ends of the cables do not touch each other, adjacent terminals, or the receiver's chassis.
- 3) Reconnect the power cord and set the SPEAKERS switch, as desired. Adjust all other receiver controls in the usual manner.

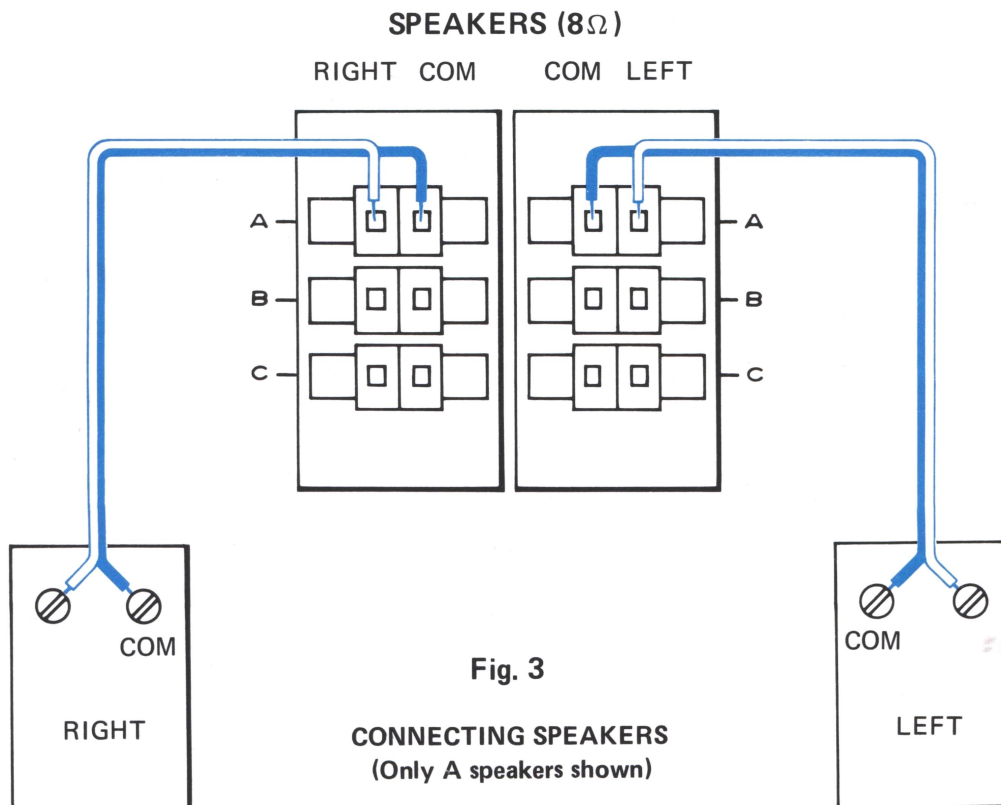

ANTENNAS

FM ANTENNAS (Refer also to INSTALLING section)

The following paragraphs provide instructions for replacing the FM-dipole antenna with other indoor or outdoor antennas to suit local receiving conditions:

REDUCING MULTIPATH INTERFERENCE

In some strong-signal localities, pronounced signal reflections from surrounding buildings, towers, or hills may cause multipath interference. (This phenomenon is similar to "ghosts" in TV pictures and can cause distortion, "fuzziness", and reduced left-right separation in FM-stereo broadcasts.)

In such cases, it may be necessary to replace the dipole antenna with an indoor "rabbit-ears" or telescoping-dipole antenna that can be rotated for best reception of the desired signal and maximum rejection of the unwanted reflections. (This type of antenna is available at most electronic-parts dealers.)

Disconnect the dipole antenna from the FM ANT. terminals and connect the rabbit-ears antenna in its place, making sure that the antenna lugs or wires do not touch each other, adjacent terminals, or the receiver chassis. Tune in several FM stations and rotate the antenna for best reception of each.

IMPROVING FRINGE-AREA RECEPTION AND REDUCING ELECTRICAL INTERFERENCE

In weak-signal "fringe" areas an outdoor antenna may be necessary, especially for effective, noise-free FM-stereo reception. If you already have an outdoor VHF television antenna, and know that FM signals in your area come from the same general direction as the TV signals, the antenna may prove suitable for FM reception as well. To test it, disconnect the dipole antenna from the FM ANT. terminals and connect the TV antenna in its place, making sure that the antenna lugs or wires do not touch each other, adjacent terminals, or the receiver chassis. If the results are satisfactory, obtain a two-set antenna coupler so that you can operate both the TV set and the receiver from the antenna simultaneously.

If reception is still unsatisfactory, you may have to connect an outdoor antenna designed specifically for FM. In medium-fringe areas (up to 40 miles from stations), where most signals come from the same general direction, a folded dipole with reflector should provide good results. If signals come from several different directions, an omnidirectional antenna such as a cross-dipole, "turnstile", or "S" will eliminate the necessity for an antenna rotator. For deep fringe areas 50 miles or more from stations, a high-gain "Yagi" array or Log-Periodic antenna is recommended. These antennas are quite directional however, and if station signals come from several directions, you will probably require a remote-control antenna rotator.

If you live near a busy thoroughfare or industrial area, and the outdoor antenna is connected to the set with conventional 300-ohm twin-lead, interference from automotive ignition systems or electrical machinery may radiate into the long lead-in, causing objectionable noises throughout the FM band. In such cases, replace the conventional lead-in with shielded 75-ohm cable (available at your local Hi-Fi store). Connect the lead-in's two signal conductors to the receiver's 75-ohm FM ANT. terminals in the manner, shown in the INSTALLING section.

AM ANTENNAS

If AM reception is marred because you live in a steel-frame building, or if you want to supplement the built-in AM antenna for improved reception of weaker stations, connect 10 to 20 feet of insulated, flexible, single-conductor wire to the EXT AM ANT. terminal. Keep this wire away from all speaker, audio, and power cables. Run the wire in a straight line along a non-metallic baseboard or under a rug. In some cases, reception may be further improved by draping the wire out a window or by connecting it to an outdoor whip or rod antenna.

ADDITIONAL COMPONENTS

CAUTION: Do not connect any additional components without first turning off the receiver.

STEREO RECORD PLAYER OR CHANGER

Connect a stereo record player or changer having a magnetic cartridge exactly as shown in the INSTALLING section. If the record player or changer has a ground wire with a spade or hook lug at its free end, connect this lug to the slotted-head ground screw near the receiver's PHONO 1 jacks. This is important for hum-free sound from your records. Usually, the record player's OPERATING INSTRUCTIONS Manual will tell you how to distinguish between the left- and right-channel audio cables. If not, temporarily connect them at random and connect the record player's power cord to the switched AC outlet at the rear of your receiver. Then check for correct left-right stereo placement as follows: Turn on the receiver, make sure that the MONO MODE button is out, and set the FUNCTION switch to PHONO 1 or 2, depending on the rear terminals to which your record player or changer is connected. Play a stereo symphonic or orchestral recording and adjust the VOLUME control for a comfortable listening level. Listen to the placement of the violins; if they seem to come from — or near — the left speaker, as viewed from your listening position, the cables are properly connected. If not, turn off the receiver and reverse the connections of the audio cables.

AUXILIARY PROGRAM SOURCE

You may increase the versatility of the receiver by playing an additional program source through the AUX jacks. If the source plays through its own low-fidelity speaker(s) and amplifier(s), playing it through the receiver instead will improve its sound quality.

The auxiliary source may be a short-wave or multiband radio tuner, a TV set or sound-movie projector, or any other similar device so long as it has at least one audio output jack. The jack is generally marked LINE OUTPUT, TO AMPLIFIER, TO TAPE RECORDER, or the like. If the device does not have the required jack, a qualified service technician can install one and, if necessary, add provisions for switching off its built-in speakers. If the device is an AC/DC or "transformerless" type, make sure that the technician eliminates shock hazard and hum caused by a "hot" (electrically not isolated) chassis. If you are in doubt about the safety characteristics of the device, do not connect it to the receiver.

- 1) Turn off the receiver. Depending on whether the auxiliary device is mono or stereo, connect it to the receiver as follows:
 - If the device is mono, connect its single output jack to the receiver's LEFT and RIGHT AUX jacks. (Use a shielded "Y"-connector audio cable with the appropriate plug on each of its three legs.)
 - If the device is stereo connect its LEFT, L, A, or 1 output jack to the receiver's LEFT AUX jack, and its RIGHT, R, B, or 2 output jack to the receiver's RIGHT AUX jack.

(Use two shielded audio cables with the appropriate plugs at their ends.)

- 2) Connect the device's power cord to a convenient electrical outlet. Keep the power cord away from all shielded cables.
- 3) Turn on the receiver and the auxiliary device, turn the FUNCTION switch to AUX position, and set the receiver's VOLUME control to a comfortable level.
- 4) Turn the FUNCTION switch either to FM or AUX positions, and compare the relative volume levels of the two program sources. They should be approximately equal without your having to readjust the VOLUME control drastically each time you switch. If the auxiliary device has any controls that affect its volume (as heard through the receiver), adjust them to equalize volume levels.

EXTERNAL TAPE RECORDER OR DECK

Your receiver has provisions for connecting a tape recorder or tape deck so that you may record any program source to which you are listening. If the receiver's AUX jacks are presently unused, you may also connect the recorder to play back the recording (or any previously recorded tape) through the receiver at your convenience. In any event, the recorder may be an open-reel, tape-cassette, or tape-cartridge type.

CONNECTING ONE RECORDER

The following instructions (and illustration in the INSTALLING section) will permit you to record any program source to which you are listening, and then to play back the recording (or any previously recorded tape) through the receiver at your convenience. (If the recorder is specially equipped as described in step 5, the receiver will also permit you to "monitor" the quality of the taped signal while recording.)

- 1) Turn off the receiver. The stereo recorder should have a pair of high-level recording input jacks marked HIGH LEVEL, LINE INPUT, or the like. Using two shielded audio cables with the appropriate plugs at their ends, connect the LEFT, L, A, or 1 jack to the receiver's LEFT TAPE-1 OUT jack, and the RIGHT, R, B, or 2 jack to the receiver's RIGHT TAPE-1 OUT jack.
- 2) The recorder should also have a pair of playback output jacks marked PLAYBACK OUTPUT, CATHODE FOLLOWER, LINE OUTPUT, MONITOR, EXTERNAL AMPLIFIER, or the like. Using two more shielded audio cables with the appropriate plugs at their ends, connect the LEFT, L, A, or 1 jack to the receiver's LEFT TAPE-1 IN jack, and the RIGHT, R, B, or 2 jack to the receiver's RIGHT TAPE-1 IN jack.
- 3) Connect the receiver's power cord to the unswitched AC outlet at the rear of your receiver. Keep the power cord as far as possible from all shielded audio cables.

- 4) To record, turn on the receiver and the recorder. Choose the desired program source with the receiver's FUNCTION switch; the source to which you are listening is the source that will be recorded. Then operate the recorder in the recording mode as specified in its OPERATING INSTRUCTIONS Manual. The FUNCTION switch is the only receiver control that has any effect on the recording (except, of course, the Tuning control if you are recording a radio broadcast); you may therefore adjust all other controls in the usual manner as described in the OPERATING section.
- 5) If your recorder has true tape-monitor facilities (different circuits and heads for recording than for playback), you may monitor the tape — while recording — to compare its sound quality with that of the original program from which it is being recorded. This feature permits you to detect and correct any possible recording errors almost immediately. To monitor, alternate the receiver's TAPE MONITOR 1 button between SOURCE (to hear the original program as usual) and TAPE (to hear the same material, a fraction of a second later, as it sounds on tape). You may repeat this as often as you like, or even keep the button in TAPE without affecting or interrupting the recording process in any way. When you have finished recording, remember to depress the TAPE MONITOR 1 button to SOURCE so that you do not accidentally silence any other program source chosen with the FUNCTION switch.
- 6) To play back tapes, simply depress the receiver's TAPE MONITOR 1 button to TAPE and operate the recorder in the playback mode as specified in its OPERATING INSTRUCTIONS Manual. Adjust all other receiver controls in the usual manner as described in the OPERATING section. When you have finished playing tapes, remember to depress the TAPE MONITOR 1 button to SOURCE so that you do not accidentally silence any other program source chosen with the FUNCTION switch.

CONNECTING A SECOND RECORDER

This permits you to tape any phonograph record or radio broadcast on the first or second recorder, or on both recorders simultaneously. It will also permit you to play back a previously recorded tape on the first recorder while making a duplicate copy (or "dubbing") on the second recorder. Connect the second recorder's high-level recording inputs to the receiver's TAPE-2 OUT jacks, and the second recorder's playback outputs to the receiver's TAPE-2 IN jacks. To make a tape copy of a record or broadcast on the first and/or second recorder, choose the desired program source with the receiver's FUNCTION switch, and operate either or both recorders in the recording mode. To duplicate or "dub", from the first recorder to the second recorder, depress the TAPE MONITOR 1 button to TAPE and the TAPE MONITOR 2 button to SOURCE. Then operate the first recorder in the playback mode and the second recorder in the recording mode. If your recorder has true tape-monitor facilities (different circuits and heads for recording than for playback), you may monitor the tape — while recording — by depressing the TAPE MONITOR 2 button to TAPE.

To play back tapes, simply depress the receiver's TAPE MONITOR 2 button to TAPE and operate the recorder in the playback mode as specified in its OPERATING INSTRUCTIONS Manual. Adjust all other receiver controls in the usual manner as described in the OPERATING section. When you have finished playing tapes, remember to depress the TAPE MONITOR 2 button to SOURCE so that you do not accidentally silence any other program source chosen with the FUNCTION switch.

MAINTENANCE

CAUTION:

Turn off the receiver and disconnect its power cord from the electrical outlet whenever instructed to do so in the following procedures. Do not attempt any maintenance not listed in this section. For further service, consult your Fisher dealer, local Fisher Service Center, or Service Department, Fisher Corporation.

(If returning your unit for service, please do not include this OPERATING INSTRUCTIONS Manual, the Service Manual, or the dipole antenna.)

CLEANING THE RECEIVER'S EXTERIOR

The receiver's control panel and wood-grain vinyl-clad cover will retain their color and brilliance permanently. However, it is possible that, over a period of time, a film from atmospheric contamination may dull the surfaces. Simply use a soft, freshly laundered cloth moistened with plain lukewarm water to wipe the surfaces clean and your receiver will look like new again. Do not use any household or industrial cleaning agents, or any cloth that has been used to apply such agents.

REPLACING FUSES

If the TROUBLE-SHOOTING GUIDE in this OPERATING INSTRUCTIONS Manual indicates that a malfunction may be caused by a blown fuse in the rear of the set, proceed as follows:

1) Turn off the receiver and disconnect its power cord from the electrical outlet.

- 2) Turn the fuseholder cap counterclockwise until it disengages from the receptacle, and remove the fuse from the cap.
- 3) Obtain a replacement fuse whose electrical rating is identical to that marked next to the fuse receptacle or stamped on the original fuse itself.
- 4) Insert the replacement fuse in the fuse cap. Push the cap into its receptacle and turn it clockwise until it is firmly in place. Connect the power cord to the electrical outlet and turn the receiver on.

CAUTION:

If the malfunction persists or recurs within a short time, do not attempt to replace the fuse again. Consult your dealer, or local Fisher Service Center, or Fisher Corporation.

OPERATING GUIDE

		Front Panel Controls and Switches										
Program Source	Rear Input Jacks or Terminals	SPEAKERS Switch	GRAPHIC EQUALIZER All Controls	EQUAL Switch	FM MUTE Switch	MONO MODE Switch	LOUDNESS CONTOUR Switch	FM MPX, SUBSONIC FILTER Switches	TAPE MONITOR Switches	VOLUME Control	BALANCE Control	FUNCTION Switch
Mono FM	FM ANT.	A or B or C or A+B	"0" (Centered) or As Desired	ON	ON	ON	ON or OFF	OFF	SOURCE	As Desired	Centered	FM
Stereo FM	FM ANT.	A or B or C or A+B	"0" (Centered) or As Desired	ON	ON	OFF	ON or OFF	OFF	SOURCE	As Desired	Centered	FM
AM	Built-In AM Antenna	A or B or C or A+B	"0" (Centered) or As Desired	ON	ON	ON	ON or OFF	OFF	SOURCE	As Desired	Centered	AM
Mono Records	PHONO 1 or 2	A or B or C or A+B	"0" (Centered) or As Desired	ON	ON	ON	ON or OFF	OFF	SOURCE	As Desired	Centered	PHONO 1 or 2
Stereo Records	PHONO 1 or 2	A or B or C or A+B	"0" (Centered) or As Desired	ON	ON	OFF	ON or OFF	OFF	SOURCE	As Desired	Centered	PHONO 1 or 2
Stereo Tape (Playback Only)	TAPE-1 or -2 IN	A or B or C or A+B	"0" (Centered) or As Desired	ON	ON	OFF	ON or OFF	OFF	1 or 2	As Desired	Centered	Any Position
Stereo 8-Track Cartridge	AUX	A or B or C or A+B	"0" (Centered) or As Desired	ON	ON	OFF	ON or OFF	OFF	SOURCE	As Desired	Centered	AUX

Please read the OPERATING INSTRUCTIONS Manual for more detailed information.



FISHER

THE FIRST NAME IN HIGH FIDELITY

Studio-Standard

FISHER CORPORATION, 21314 LASSEN STREET • CHATSWORTH • CALIFORNIA 91311

Scans:

<https://archive.org/>