

Figure 1 - Wiring of Two-Way System

DESCRIPTION AND APPLICATIONS

Electro-Voice crossover networks are high-Q, low insertion loss, frequency discriminating filters designed for use in systems having a characteristic impedance of 8 ohms. All E-V crossovers are of constant-K configuration. The basic advantage of constant-K filters is that identical values of components may be used both in series and shunt arms, thus ensuring identical characteristics on either side of the crossover frequency.

Because high-Q air-core inductors are used in these crossover networks, filter characteristics are maintained constant despite changes in average values of program level. Electro-Voice crossovers will safely handle up to 100 RMS watts. Since the average level of program material in home listening rarely exceeds 2 watts, the safety margin inherent in the design of these units is indeed a large one.

SPECIFICATIONS

	X8	X36
Crossover Frequency:	800 Hz	3500 Hz
Impedance:	8 ohms	8 ohms
Insertion Loss,		
Lo:	.75 db	.5 db
Hi:	0 db	0 db
Attenuation Rate, per octave:	12 db	12 db
Dimensions,		
Height:	4¾ inches	3½ inches
Width:	4½ inches	4½ inches
Depth:	3-5/8 inches	3-5/8 inches
Net Weight:	4 pounds	1½ pounds

© beim Hersteller
Alteiny Michael Otto
HiFi-Classic.de

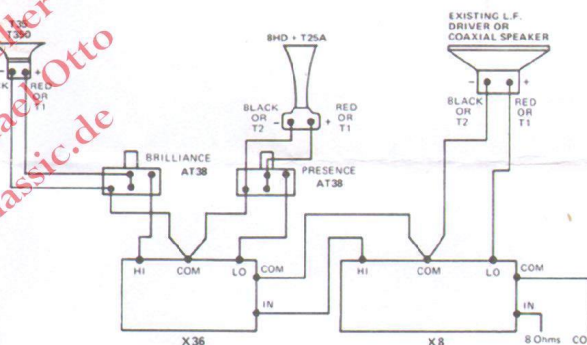

Figure 2 - Wiring of Three-Way System

TECHNICAL DATA

Typical applications of E-V networks are shown in Figures 1 and 2. Figure 1 illustrates a single crossover used to separate frequencies radiated by a VHF driver and a low-frequency or coaxial speaker. Figure 2 is typical of a three-way system in which two crossover networks are used.

Although these crossovers have been designed for use in 8-ohm systems, they may be employed in other situations. For instance, if an 8-ohm unit is used in a system in which both the input and output impedances are 16 ohms, no appreciable shift in crossover frequency will be experienced, and the insertion loss of the crossover will be reduced. In the case of reproducers with unequal impedances, the crossover should be connected to an 8-ohm source. As an example: if an 8-ohm woofer is used with a 16-ohm tweeter, the reproduction of bass will be favored. If the tweeter is an 8-ohm unit and the woofer is 16 ohms, however, then treble reproduction would be relatively louder. In either case, the high frequency level control will restore balance. The system's smoothness will also be slightly affected.

CUSTOMER SERVICE

Electro-Voice crossover networks are packed to provide protection well in excess of shipping requirements of the Interstate Commerce Commission. If, however, shipping damage has occurred, contact the carrier or the dealer from whom the unit was purchased and request inspection and instructions.

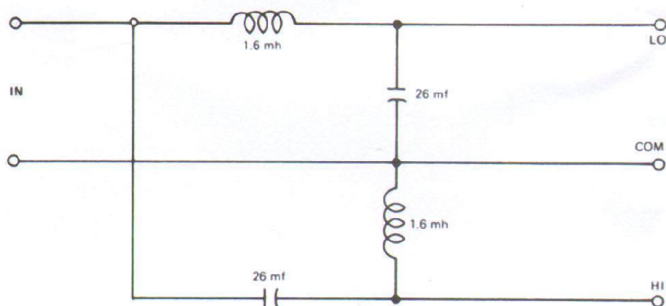

Figure 3 - Model X8 Schematic Diagram

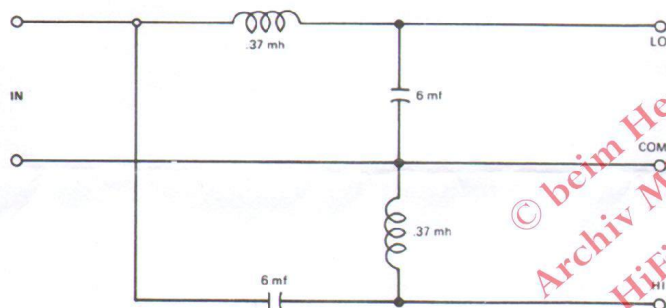

Figure 4 - Model X36 Schematic Diagram

WARRANTY (Limited) —

Electro-Voice Sound Reinforcement & Public Address Loudspeakers and accessories are guaranteed for five years from date of original purchase against malfunction due to defects in workmanship and materials. If such malfunction occurs, unit will be repaired or replaced (at our option) without charge for materials or labor if delivered prepaid to the proper Electro-Voice service facility. Unit will be returned prepaid. Warranty does not cover finish or appearance items or malfunction due to abuse or operation at other than specified conditions. Repair by other than Electro-Voice or its authorized service agencies will void this guarantee.

For correct shipping address and instructions on return of Electro-Voice products for repair and locations of authorized service agencies, please write: Service Department, Electro-Voice, Inc., 600 Cecil Street, Buchanan, Michigan 49107 (Phone 616/695-6831).

Electro-Voice also maintains complete facilities for non-warranty service.

Specifications subject to change without notice.



FEATURES

- Low insertion loss
- 12 db per octave attenuation
- Stable components for long life

DESCRIPTION AND APPLICATIONS

Electro-Voice crossover networks are high-Q, low insertion loss, frequency discriminating filters designed for use in systems having a characteristic impedance of 16 ohms. All E-V crossovers are of constant-K configuration. A basic advantage of the constant-K-type filter is that identical values of components may be used in both series and shunt arms; thus, identical characteristics are ensured on either side of the crossover frequency.

Because high-Q air-core inductors are used in these crossover networks, filter characteristics are maintained constant despite changes in average values of program level. Electro-Voice crossovers will safely handle up to 100 RMS watts. Since the average level of program material in home listening rarely exceeds 2 watts, the safety margin inherent in the design of these units is indeed a large one.

SPECIFICATIONS

	X8	X36
Crossover frequency:	800 cps	3500 cps
Impedance:	16 ohms	16 ohms
Insertion loss		
Lo:	.5 db	.75 db
Hi:	0 db	0 db
Attenuation rate:	12 db/octave	12 db/octave
Dimensions		
Height:	4-3/4"	3-1/2"
Width:	4-1/2"	4-1/2"
Depth:	3-5/8"	3-5/8"
Net weight:	4 lbs.	1-1/2 lbs.

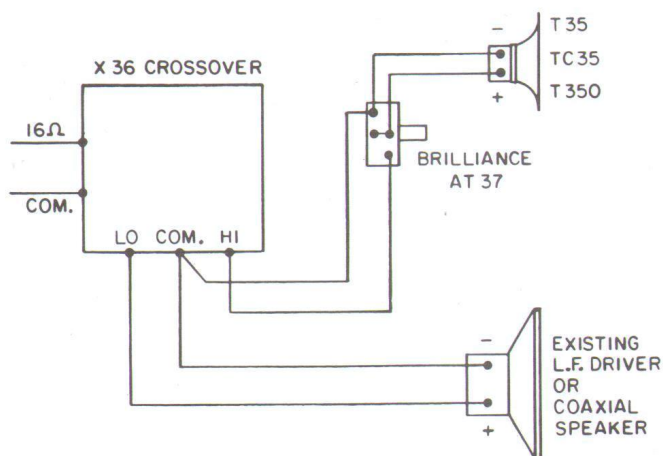

Figure 1 - Wiring of Two-Way System

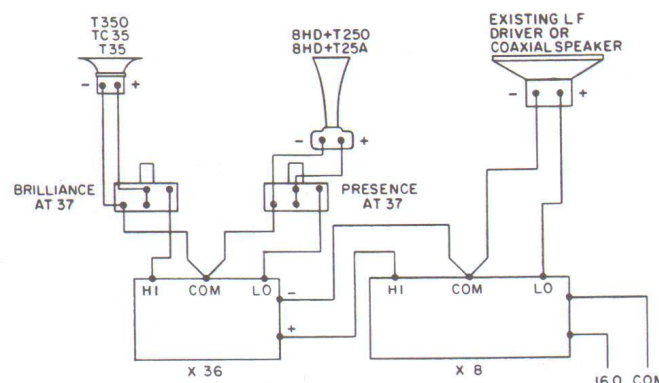

Figure 2 - Wiring of Three-Way System

TECHNICAL DATA

Typical applications of E-V networks are shown in Figures 1 and 2. Figure 1 illustrates a single crossover used to separate frequencies radiated by a VHF driver and a low-frequency or coaxial speaker.

Figure 2 is typical of a 3-way system in which two crossover networks are employed. It is not important in which order the crossovers are cascaded, the purpose of such an arrangement being merely to insure a pass band frequency response for the treble mid-range driver.

Although these crossovers have been designed for use in 16-ohm systems, they may be employed in other situations. For instance, if a 16-ohm unit is used in a system in which both the input and output impedances are 8 ohms, no appreciable shift

in crossover frequency will be experienced, although the insertion loss of the crossover will be greater. In the case of reproducers with unequal impedances, the crossover should be connected to a 16-ohm source. As an example, if an 8-ohm woofer is used with a 16-ohm tweeter, the reproduction of bass will be favored; however, if the tweeter was an 8-ohm unit and the woofer 16 ohms, then treble reproduction would be relatively louder. The system's smoothness will also be affected slightly.

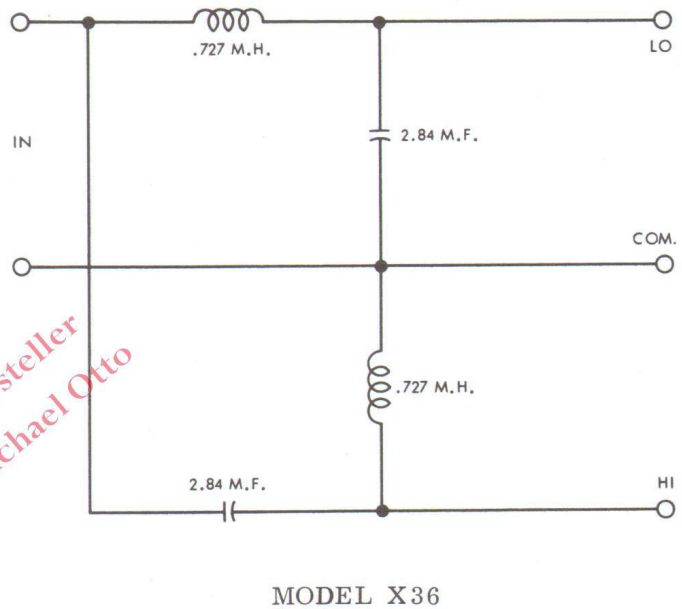
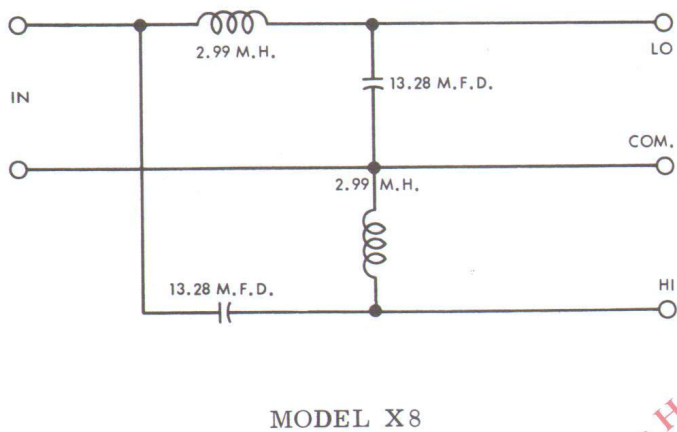

Figure 3 - Schematic Diagrams

© beim Hersteller
Archiv Michael Otto

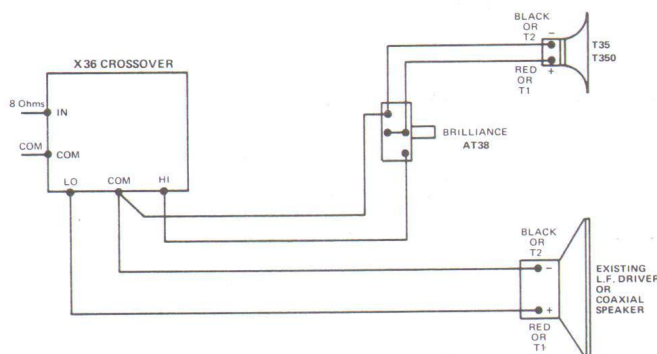

Figure 1 - Wiring of Two-Way System

DESCRIPTION AND APPLICATIONS

Electro-Voice crossover networks are high-Q, low insertion loss, frequency discriminating filters designed for use in systems having a characteristic impedance of 8 ohms. All E-V crossovers are of constant-K configuration. The basic advantage of constant-K filters is that identical values of components may be used both in series and shunt arms, thus ensuring identical characteristics on either side of the crossover frequency.

Because high-Q air-core inductors are used in these crossover networks, filter characteristics are maintained constant despite changes in average values of program level. Electro-Voice crossovers will safely handle up to 100 RMS watts. Since the average level of program material in home listening rarely exceeds 2 watts, the safety margin inherent in the design of these units is indeed a large one.

SPECIFICATIONS

	X8	X36
Crossover Frequency:	800 Hz	3500 Hz
Impedance:	8 ohms	8 ohms
Insertion Loss,		
Lo:	.75 db	.5 db
Hi:	0 db	0 db
Attenuation Rate, per octave:	12 db	12 db
Dimensions,		
Height:	4¾ inches	3½ inches
Width:	4½ inches	4½ inches
Depth:	3-5/8 inches	3-5/8 inches
Net Weight:	4 pounds	1½ pounds

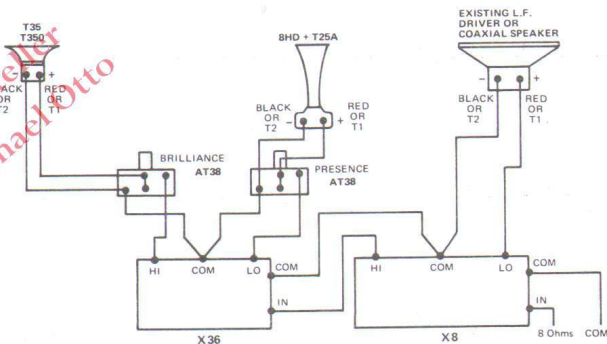

Figure 2 - Wiring of Three-Way System

TECHNICAL DATA

Typical applications of E-V networks are shown in Figures 1 and 2. Figure 1 illustrates a single crossover used to separate frequencies radiated by a VHF driver and a low-frequency or coaxial speaker. Figure 2 is typical of a three-way system in which two crossover networks are used.

Although these crossovers have been designed for use in 8-ohm systems, they may be employed in other situations. For instance, if an 8-ohm unit is used in a system in which both the input and output impedances are 16 ohms, no appreciable shift in crossover frequency will be experienced, and the insertion loss of the crossover will be reduced. In the case of reproducers with unequal impedances, the crossover should be connected to an 8-ohm source. As an example: if an 8-ohm woofer is used with a 16-ohm tweeter, the reproduction of bass will be favored. If the tweeter is an 8-ohm unit and the woofer is 16 ohms, however, then treble reproduction would be relatively louder. In either case, the high frequency level control will restore balance. The system's smoothness will also be slightly affected.