

Electro-Voice®
a gulton company

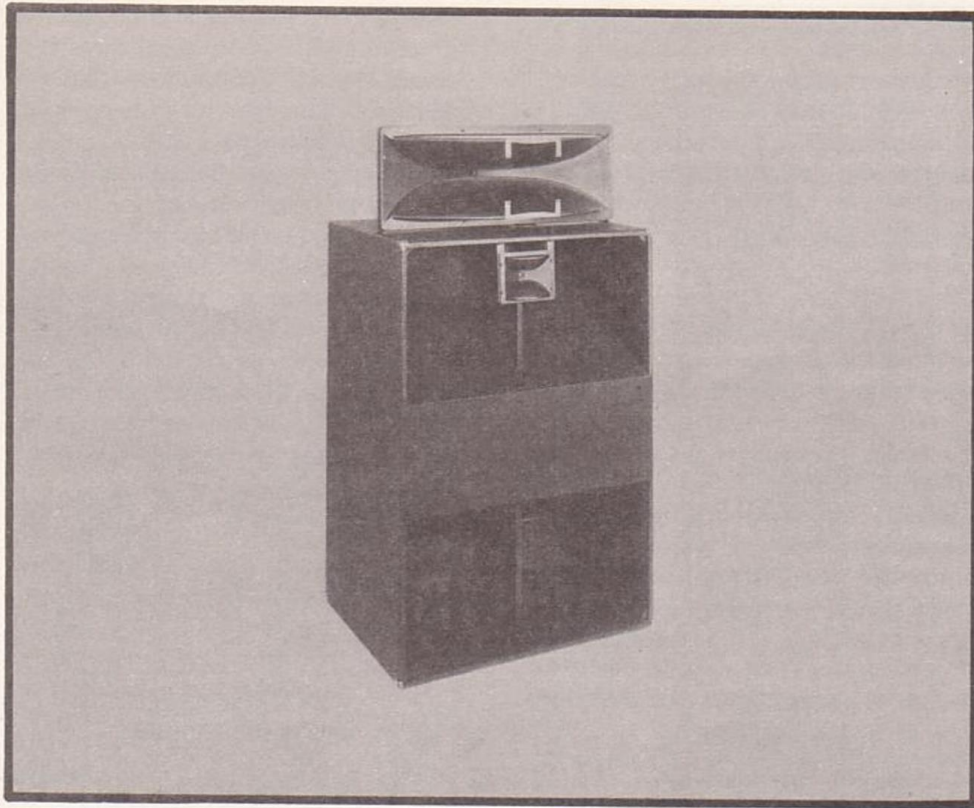

Sentry IVB Professional Loudspeaker System

SPECIFICATIONS

Frequency Response:
50 to 18,000 Hz
(see Figure 1)

EIA Sensitivity (on axis measurements):
52 dB

Sound Pressure Level (4' on axis, 50 W):
117 dB

Impedance:
8 ohms nominal

Power Handling Capacity:
50 W (see explanation)

Finish:
Utility Black

Size:
70.5 cm (27 3/4") w. x 52.3 cm
(20-5/8") d. x 129 cm
(50 3/4") h. - in normal configuration

Weight:
67 Kg (148 pounds)

DESCRIPTION AND APPLICATIONS

The Electro-Voice Sentry IVB incorporates many new and innovative design ideas which represent a significant advance in state-of-the-art speaker design. The 3-way, all horn loaded system offers absolute minimum distortion through all frequencies while providing unequalled efficiency and uniformity over the entire frequency range. With high power handling capacity, extremely uniform and wide dispersion, and linear frequency response, the Sentry IVB offers versatility for applications in not only studio monitoring,

*© beim Hersteller
Archiv Michael-Otto*

but in high level sound reinforcement, high level playback systems, etc. The midrange and tweeter horn designs represent the first significantly new sectoral design in 25 years with vertical dispersion of greater than 60-degrees at all frequencies and extremely stable horizontal dispersion at 120-degrees virtually throughout the frequency range, these horns offer a uniformity of coverage which practically eliminate "hot spots" and "dead areas" in the control room or elsewhere (see Figure 2). Totally new drivers are associated with the midrange and high-frequency components to offer both ruggedness and linear response.

The woofer section utilizes the folded

horn principle for increased efficiency and lower distortion. The design of the enclosure permits linear low-frequency response to within a few cycles of the theoretical enclosure cutoff frequency of 50 Hz. Two 12-inch cone drivers are used in the folded horn low-frequency section.

The crossover provides push clip terminals for connection of all components.

A female phone plug receptacle is provided for bi-amping high-frequency input. For those who wish to use an active crossover, all high-frequency information should be routed into the crossover via this receptacle. In this way the crossover between woofer and midrange (400 Hz) is bypassed.

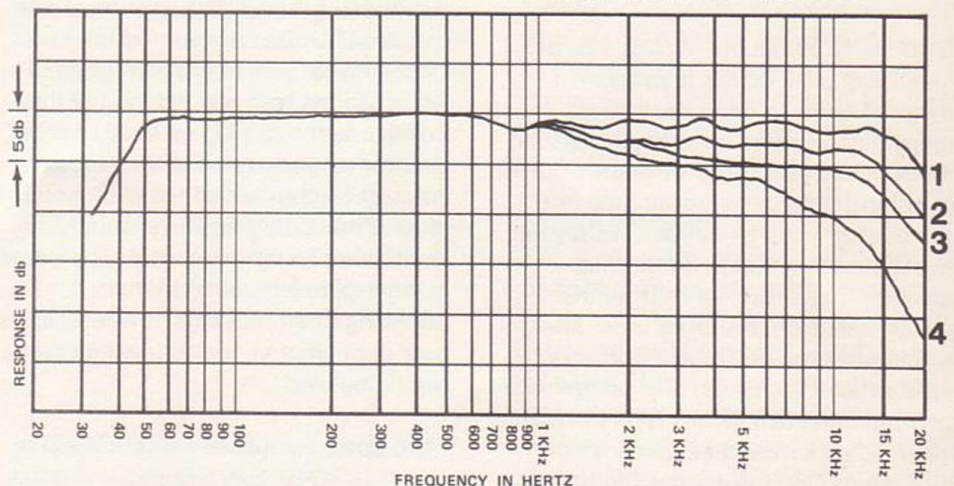

FIGURE 1 — Frequency Response
(average axis pressure under anechoic conditions)

A high-frequency rolloff attenuator is provided on the crossover which increases effective power handling capacity by smoothly attenuating tweeter input power.

POWER HANDLING CAPACITY

In an effort to provide a meaningful power rating, the frequency spectrum of the lead guitar in several prominent groups was band-analyzed. A filter was designed that would shape white noise (a sound similar to between-station FM noise, consisting of all frequencies from 20 to 20,000 Hz simultaneously) to the typical lead guitar spectrum. The lead guitar frequency spectrum is far more demanding at the frequency extremes than voice or conventional music program material. Filtered white noise is fed into the system at various levels to determine the power handling capacity.

With the attenuator in the No. 1 position (flat) the continuous power handling capacity (above defined and assuming a nominal 8 ohm load) is 50 watts. With the attenuator in the No. 2 position, the power handling is 75 watts continuous. In No. 3 position, it is 125 watts continuous. The fourth attenuator position almost completely attenuates the upper range of the tweeter output and significantly increases power handling capacity.

Figure 6 shows continuous sine wave power handling with relation to frequency. The graph is designed to be used to calculate power handling when unusual program sources with substantial high frequency energy are anticipated. ***A continuous voltage of 4 volts into the tweeter should not be exceeded when using noise inputs.***

CAUTION: While the normal area of maximum peak power in program material tends to be in the 500 Hz range, fast winding of professional tape machines at five to six times the normal speed shifts the peak power area into the tweeter which, in effect, causes the tweeter to function as a full-range speaker. In addition to shifting the power spectrum, transient times are accelerated and destructive forces are substantially increased. ***The tweeter will not tolerate much of this type of treatment,*** so care should be taken when high winding to assure that the tape is lifted from the playback head.

CONNECTING THE SENTRY IVB

The Sentry IVB is shipped in two separate packages. After unpacking the low-frequency section, the high-frequency subassembly may be unpacked and assembled. Seven brackets and the appropriate hardware for mounting are shipped with the high-frequency assembly. (See Figure 3 for normal assembly.)

In the normal mounting configuration, the midrange/crossover assembly is secured to the top of the low-frequency section, and the tweeter is suspended in the upper wave path of the low-frequency section. If the high-frequency assembly is used with a different low-frequency system, the tweeter can be suspended from the front of the mid-range horn by using the 12.7 in. long brackets and four #10 lag screws.

Phasing — In the classical configuration for the 12 dB per octave crossover, the woofer should be connected out of phase with the high-frequency components. However, since phasing conditions in an unspecified electrical crossover cannot be anticipated, the following procedure is recommended for optimum phasing in any given situation: introduce a sine wave at the crossover frequency (between 400 and 450 Hz depending on the crossover) to the system. By switching phasing of the high-frequency half of the system, select the phasing configuration which gives the loudest output at any given crossover frequency.



FIGURE 2 — Frequency Dispersion

In the event that this wiring is disconnected for one reason or another, it must be noted that the tweeter and midrange sections should be connected in phase with one another while the low-frequency section should be out of phase with the tweeter and midrange. Output leads (power leads) from the amplifier should be connected at the input terminals with the positive lead connected to the red input terminal, causing the low-frequency section to be in phase with the amplifier output. (see Figure 5.)

ELECTRICAL CONNECTIONS

The crossover section is shipped with the midrange driver already wired and the leads for the tweeter and the low-frequency section already attached. The white striped lead corresponds to the positive terminal (T1) on both tweeter and midrange driver, and the woofer connection is provided for with a phone plug. (Phone plug tip corresponds to positive or T1 terminal, while the sleeve is the negative terminal.) When designing or employing a low-level crossover in bi-amping, the following criteria should be used:

- Crossover frequency—400 to 450 Hz.
- Crossover sloping—12 dB per octave or greater.

TWEETER PROTECTION

A tweeter protection device is provided to allow maximum performance without tweeter damage. The device senses for maximum safe voltage to the tweeter and opens the tweeter circuit (1 millisecond relay) if that voltage is exceeded. When safe voltage is resumed the tweeter is instantly brought back into the circuit.

The protector is located under the horn in front of the crossover. The wires from the input of the protector should be connected to the tweeter terminals on the crossover (striped lead to black terminal) and the output wires of the protector to the tweeter itself (striped lead to terminal T1).

INSTALL OPPOSITE SIDE IN SAME WAY

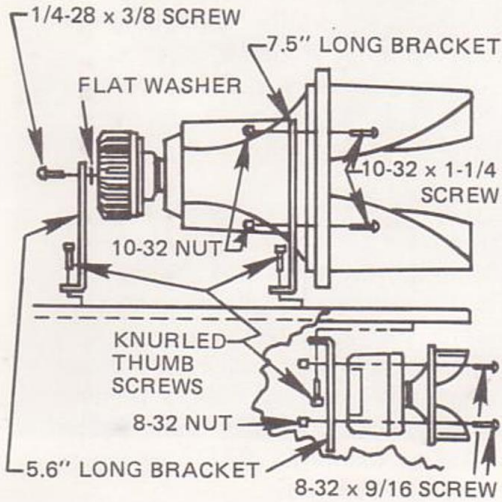

FIGURE 3 – Bracket Assembly

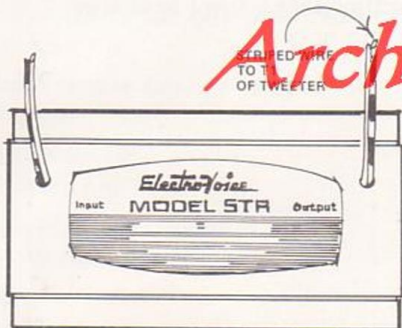

FIGURE 4 – Wiring of Tweeter Protector

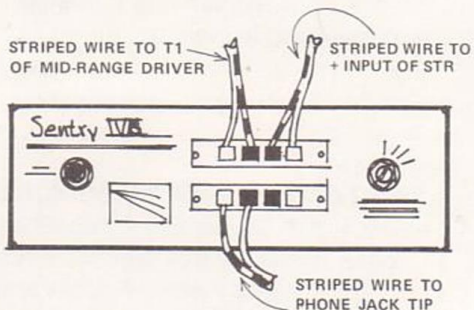

FIGURE 5 – Crossover Wiring

NOTE: When the system is operating at maximum power threshold, the tweeter may switch in and out with a clicking sound. To relieve the tweeter, either lower the power or roll the tweeter off one additional position at the crossover.

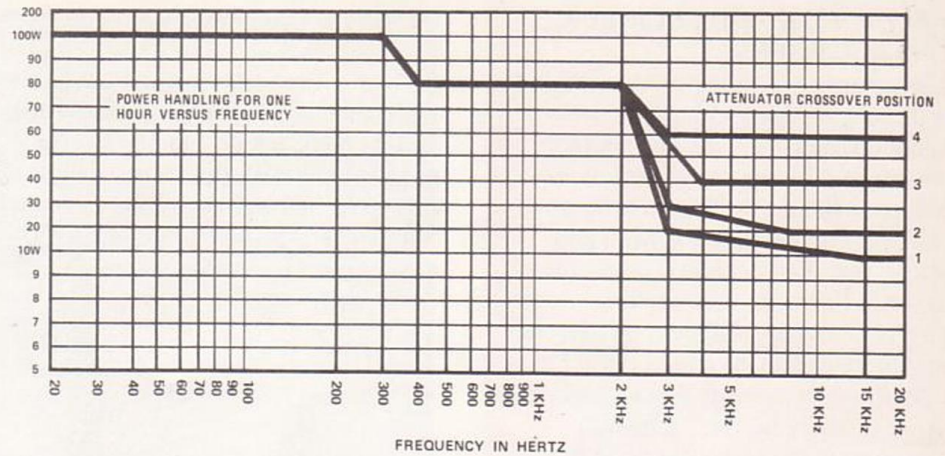

FIGURE 6 – Power Handling Chart (average sine wave power, nominal 8 ohm load)

SYSTEM LAYOUT

Accurate system layout with the Sentry IVB may be made by referring to the axial frequency response of Figure 1 as well as the octave band random noise polar response of Figure 2. From these figures, the sound pressure level available at a distance of 4 feet with full power in (50 watts) may be determined for any octave band at any angle.

the reverberant field if satisfactory intelligibility is to be obtained. This condition is fulfilled if the listener is no more than four times critical distance from the loudspeaker.

Level Variation with Power: Each time the power delivered to the speaker is halved, a drop of 3 dB occurs, in any type of environment. The nomograph of Figure 7 shows this effect.

Level Variations with Distance: Non-Reverberant Environments: In a non-reverberant environment (such as out-of-doors) sound pressure level will drop 6 dB every time the distance from the speaker is doubled (inverse square law). The nomograph of Figure 7 shows the dB losses to be expected as distance from the Sentry IVB is changed.

Level Variations with Distance: Reverberant Environments Indoors: Where sound is reflected from walls and other surfaces and the environment is reverberant, there is a point (the "critical distance") beyond which the "reverberant field" dominates and sound pressure is nearly constant. This distance is typically ten to twenty-five feet from the speaker and is shortest for the most reverberant rooms. Because of the reverberant field, the sound pressure level obtainable in a room is much higher and more constant than that predicted by inverse square law alone. However, the information in Figures 1 and 2 is still necessary in order to obtain satisfactory distribution of the sound direct from the loudspeaker ("direct field"), which still follows the inverse square law.

In installations where applicable, it is good practice to make sure that the direct field is no more than 12 dB below

WHEN TWO SIGNALS DIFFER BY:	ADD TO THE LARGER READING
0 dB	3.00 dB
1	2.50
2	2.10
3	1.70
4	1.40
5	1.10
6	.97
7	.79
8	.63
9	.51
10	.43
11	.35
12	.26

Level Variations due to Multiple Speakers: The chart above indicates the total sound pressure level resulting from two loudspeakers aimed at the same point. This chart greatly facilitates layout of systems employing multiple speakers.

ENVIRONMENT

The Sentry IVB professional system was designed for one-quarter to one-half-space use. The unit should be as close to reflecting planes as possible so that out of phase low-frequency irregularities from the reflected wave may be avoided. Cavities around the device are undesirable, as cavity resonances may be excited.

ARCHITECTS' AND ENGINEERS' SPECIFICATIONS

The speaker is a 3-way all-horn-loaded wide-range system with high power-handling capacity. Low end should consist of a folded horn housing two 12" cone drivers. Midrange should consist of a 120° sectoral horn and driver, and the high end should consist of a 120° sectoral tweeter with integral driver. Electrical crossover frequencies should be at 400 Hz and at 3500 Hz. Low-frequency cutoff should occur at approximately 50 Hz. Frequency response should be smooth and flat (in ¼- to ½-space coupling) from 50 Hz to 18,000 Hz. Dispersion of the system should be uniform with no lobes from 600 Hz to 18,000 Hz. Horizontal dispersion should be 120° with vertical dispersion at 60°.

A tweeter protector is provided to save the tweeter from surges of excess power such as feedback and some forms of program material. It automatically disconnects the tweeter as power exceeds the tweeter's power handling capacity (see Figure 6) and reconnects the tweeter when power levels are safe.

In the crossover No. 1 position, power handling should be 50 watts continuous (8 ohm nominal load) using a suitable noise input shaped to the lead guitar spectrum; No. 2 position, 75 watts; No. 3 position, 125 watts, and No. 4 substantially higher.

WARRANTY (Limited) —

Electro-Voice Sentry Loudspeakers and accessories are guaranteed for five years from date of original purchase against malfunction due to defects in workmanship and materials. If such malfunction occurs, unit will be repaired or replaced (at our option) without charge for materials or labor if delivered prepaid to the proper Electro-Voice service facility. Unit will be returned prepaid. Warranty does not cover finish, appearance items, burned coils, or other malfunction due to abuse or operation at other than specified conditions. Repair by other than Electro-Voice or its authorized service agencies will void this guarantee.

For correct shipping address and instructions on return of Electro-Voice products for repair and locations of authorized service agencies, please write: Service Department, Electro-Voice, Inc., 600 Cecil Street, Buchanan, Michigan 49107 (Phone: 616/695-6831) or 8234 Doe Avenue, Visalia, California 93277 (Phone: 209/625-1330,-1).

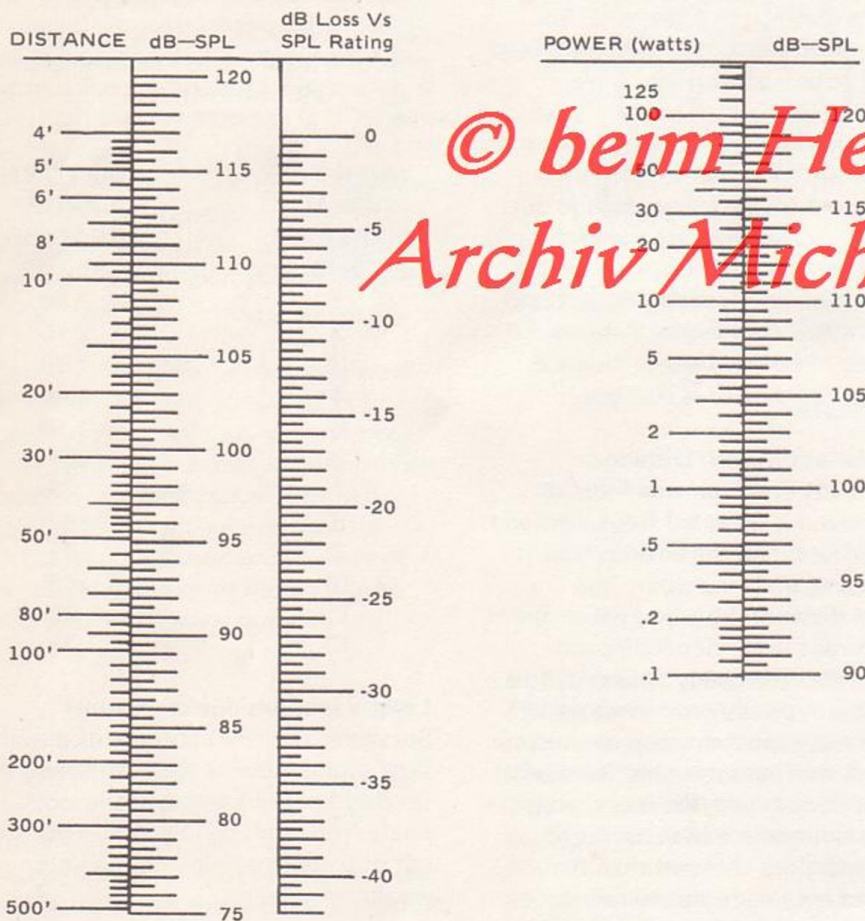

FIGURE 7 — Nomographs

*© beim Hersteller
Archiv Michael-Otto*

Electro-Voice also maintains complete facilities for non-warranty service.

Specifications subject to change without notice.

LAUTSPRECHER

The Sentry IVB is a wide-range threeway speaker System for use when the maximum efficiency of an all-hornloaded design is necessary, and/or when a wide, uniform coverage angle is needed. The Sentry IVB is an excellent choice for auditoriums, theaters and behind-the screens at cinemas.

The low-frequency section is a folded horn design incorporating two EVM-12L Series 11 12-inch speakers. The HFSA high-frequency section includes mid- and high-range reproducers and the System crossover network. Exceptionally even coverage above 400 Hz is provided by the constant coverage 120° horn and ST 350B tweeter.

The ST 350B is protected from excessive peak and long-term-average power inputs by the STR Tweeter protector. The integral crossover network provides crossover frequencies of 400 and 3500 Hz, as well as the frequency tailoring necessary to produce uniform axial frequency response. This response and the unusually uniform coverage angle provide a level of Performance not typically associated with theater-type speaker systems.

The Sentry IVB may be bi-amplified at a 400-to-450 Hz crossover frequency.

TECHNISCHE DATEN

Frequency Response ± 5 dB: 40-18,000 Hz,

Power Handling: 75W, Nominal Impedance: 8 ohms

Dispersion: H V

1,000 Hz: 113° x 180°, 2,000 Hz: 130° x 128°, 4,000 Hz: 112° x 86°

8,000 Hz: 116° x 70°, 16,000 Hz: 102° x 50°

Sound Pressure Level: 1 Watt at 10 Ft: 92 dB

Full Power at 4 Ft: 119 dB

Dimensions (HWD): 50.8" x 27.8" x 20.6",

Weight: 148 lb