



**FEATURES**

- Continuously Variable-D\* cardioid principle provides uniform directional pattern at all frequencies.
- Integral equalizer provides six response curve variations.
- Built-in isolation mount and windscreen provide protection from mechanical shock and wind noise.
- Exclusive Electro-Voice Acoustalloy® moving element for wide, smooth frequency response.

**SPECIFICATIONS**

Generating Element: Dynamic  
 Frequency Response: Uniform 40 to 10,000 cps (see Figure 1)  
 Polar Pattern: Cardioid (see Figure 2)  
 Impedance: 50, 150, 250 ohms, selected at rear of case by moving one pin. Connected for 150 ohms when shipped.  
 Output Level: -51 db on 250 ohm tap  
 -51 db on 150 ohm tap  
 -52 db on 50 ohm tap  
 (Ref: 1 mw / 10 dynes/cm<sup>2</sup>, response selector in A-1 position)  
 EIA Sensitivity Rating: -149 db on 250 ohm tap  
 -145 db on 150 ohm tap  
 -150 db on 50 ohm tap  
 (response selector in A-1 position)  
 Switching: Response and impedance selection accomplished with gold-silver plated pins.  
 Hum Pickup Level: -121 dbm, (ref. .001 gauss field)  
 Diaphragm: Electro-Voice Acoustalloy®  
 Finish: Non Reflecting Gray  
 Cable Connector: Cannon UA-3-11  
 Cable: 2-conductor, shielded, mechanical isolation cable and 20 foot, 3-conductor, shielded field cable.  
 Net Weight: 1 lb., 8 oz. (less 20-foot cable)

**DESCRIPTION AND APPLICATIONS**

The Model 667A is a dynamic cardioid microphone designed for boom mounting in broadcasting and recording. Not simply an improvisation on existing equipment, the 667A has been created specifically to overcome the problems encountered in boom applications. A specially designed shock mount provides effective isolation from mechanical noise, and the integral Acoustifoam™ windscreen virtually eliminates noise caused by motion of the microphone through the air. Unusually light in weight, the 667A is easily maneuverable. The shock isolation and windscreen systems are readily removable for service or replacement. Very low sensitivity to induced hum permits use close to lights, A.C. lines, etc.

An outstanding feature of the 667A is the self-contained computer-type programming board which permits a total of six different frequency response curves. The programming panel is part of a versatile passive equalizer which is completely self-contained: no external equipment or special connecting cables are required. The variations from flat response thus made available permit the 667A to overcome acoustical problems and background noise, make possible special effects, and enable its use mixed with existing microphones of differing responses.

Use of Continuously Variable-D, a highly developed version of the patented Electro-Voice Variable-D® principle, makes possible extremely uniform re-

jection of unwanted background noise. The rejection pattern is unusually symmetrical in all planes. The CV-D principle as employed in the 667A makes use of a matched pair of slotted tubes coupled to the back of the diaphragm. The acoustic length of the tubes varies inversely with sound frequency, permitting them to phase out unwanted sound from all portions of the audible spectrum for maximum front-to-back ratio. The microphone's single moving element is a diaphragm of Electro-Voice Acoustalloy®, which is impervious to effects of temperature, humidity, and shock. CV-D permits optimum diaphragm damping, impossible with less sophisticated designs, for absolute minimum wind and mechanical noise pickup and proximity effect.

### WARRANTY

The Model 667A, like all E-V professional microphones, is guaranteed UNCONDITIONALLY against malfunction for two years from date of purchase. Within this period, Electro-Voice will repair or replace, at no charge, any 667A exhibiting any malfunction, regardless of cause, including accidental abuse. In addition, the 667A is guaranteed for life against defects in the original workmanship and materials.

### ARCHITECTS' AND ENGINEERS' SPECIFICATIONS

The microphone shall be a cardioid dynamic type with uniform frequency response from 40 - 10,000 cps. The diaphragm shall be nonmetallic Acoustalloy® and shall have a magnetic shield to prevent dust and iron particles from reaching the diaphragm. The microphone shall be provided with two slotted tubes at the back of the diaphragm, the acoustic impedance of which shall cause the tubes to act effectively as point source entrances which vary in distance from the diaphragm inversely with frequency. The resulting phase and amplitude conditions shall provide a smooth unidirectional polar characteristic that is effectively a cardioid of revolution.

An integral passive equalizer network shall be provided by means of which the choice of two variations of high-frequency response (identified as A or B) and a choice of three variations of low-frequency response (identified as 1, 2 or 3) may be selected. Selection of desired high- and low-frequency response variations and 50, 150, or 250 ohm impedance shall be accomplished by means of gold plated pins inserted in the proper positions in a color-coded selector panel provided in the rear of the microphone. Access to the selector panel shall be provided by removal of cap at rear of microphone.

Output level shall be -52 db when microphone is

connected to 50 ohm impedance and -51 db for 150, or 250 ohms. (Reference: 0 db = 1 mw/10 dynes cm<sup>2</sup>, with response selector in A-1 position). EIA sensitivity rating shall be -150 db for 50 ohms, -145 db for 150 ohms, and -149 db for 250 ohms, (response selector in A-1 position). Hum pickup level shall not exceed -121 db, (reference .001 gauss field).

The case shall be machined aluminum with non-reflecting gray finish. A formed Acoustifoam™ windscreen shall be provided, the end sections of which shall be cemented to members of an external shock mount assembly. Overall dimensions of the complete microphone and shock mount assembly shall not exceed 9-5/8" long by 9-1/4" high by 6-1/2" wide. A two foot, 2-conductor, shielded mechanical isolation cable shall be provided having gold plated pins for insertion in microphone selector panel at one end, and a Cannon UA-3-12 connector at opposite end. A 20 foot, 3-conductor, shielded broadcast type cable shall be furnished with Cannon UA-3-11 connector installed at one end. Net weight of complete assembly (less 20-foot cable) shall not exceed 1 lb. 8 oz. The Electro-Voice Model 667A is specified.

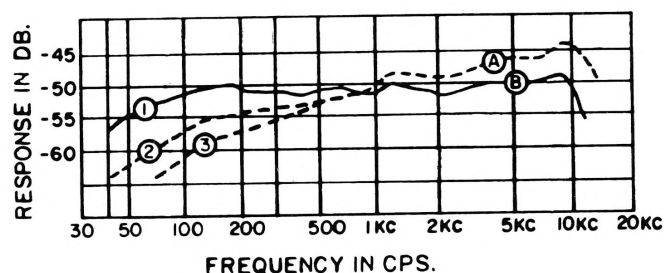

Figure 1 - Frequency Response

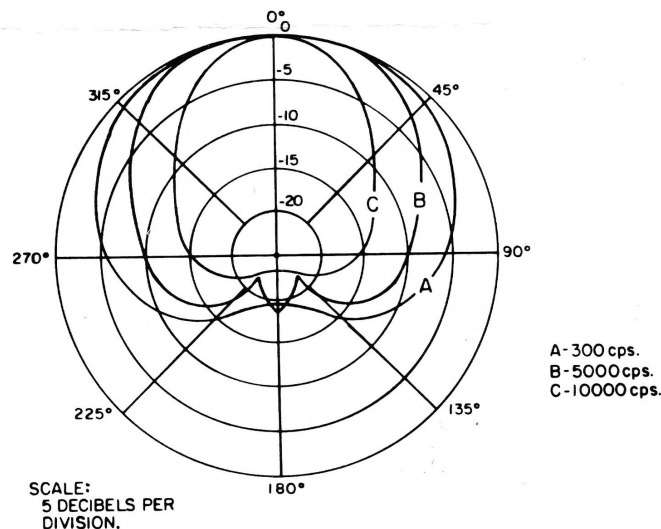

Figure 2 - Polar Pattern

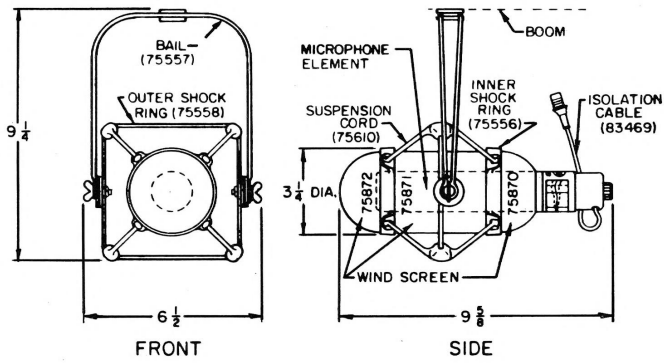

Figure 3 - Dimensions

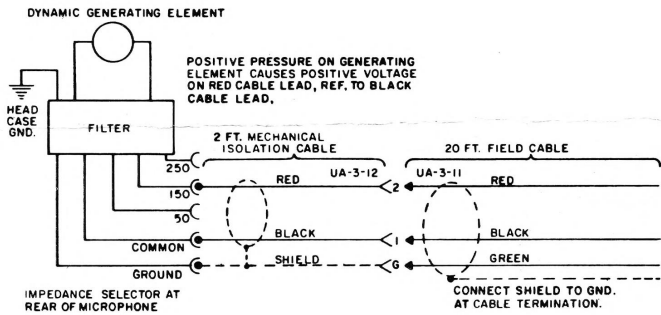

Figure 4 - Wiring Diagram

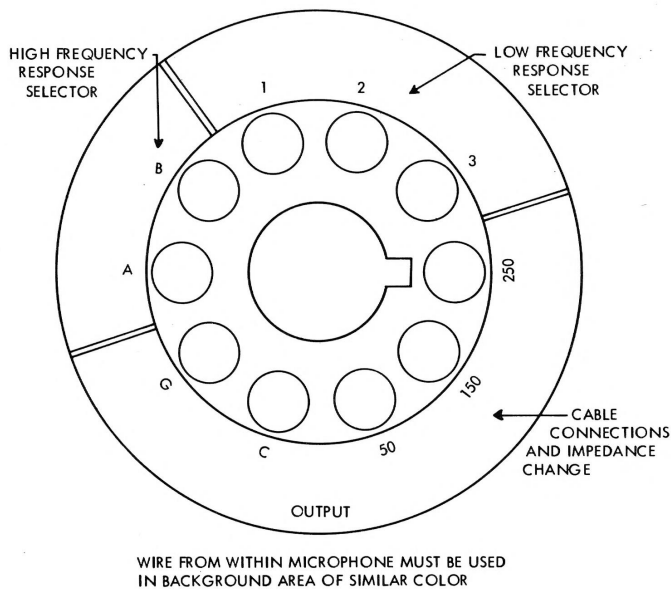
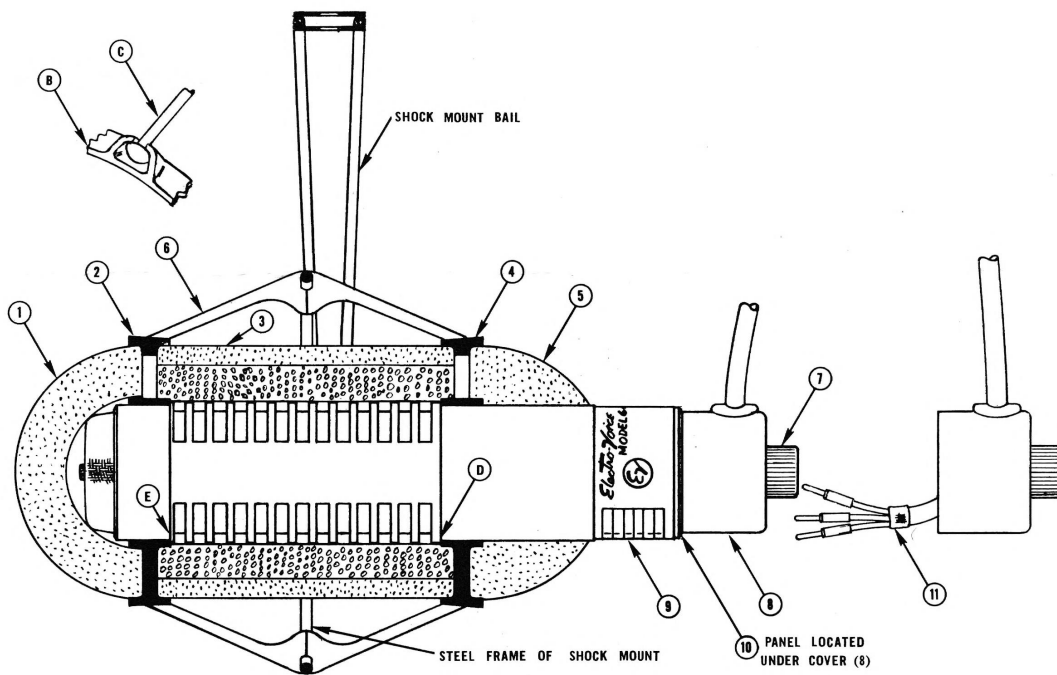
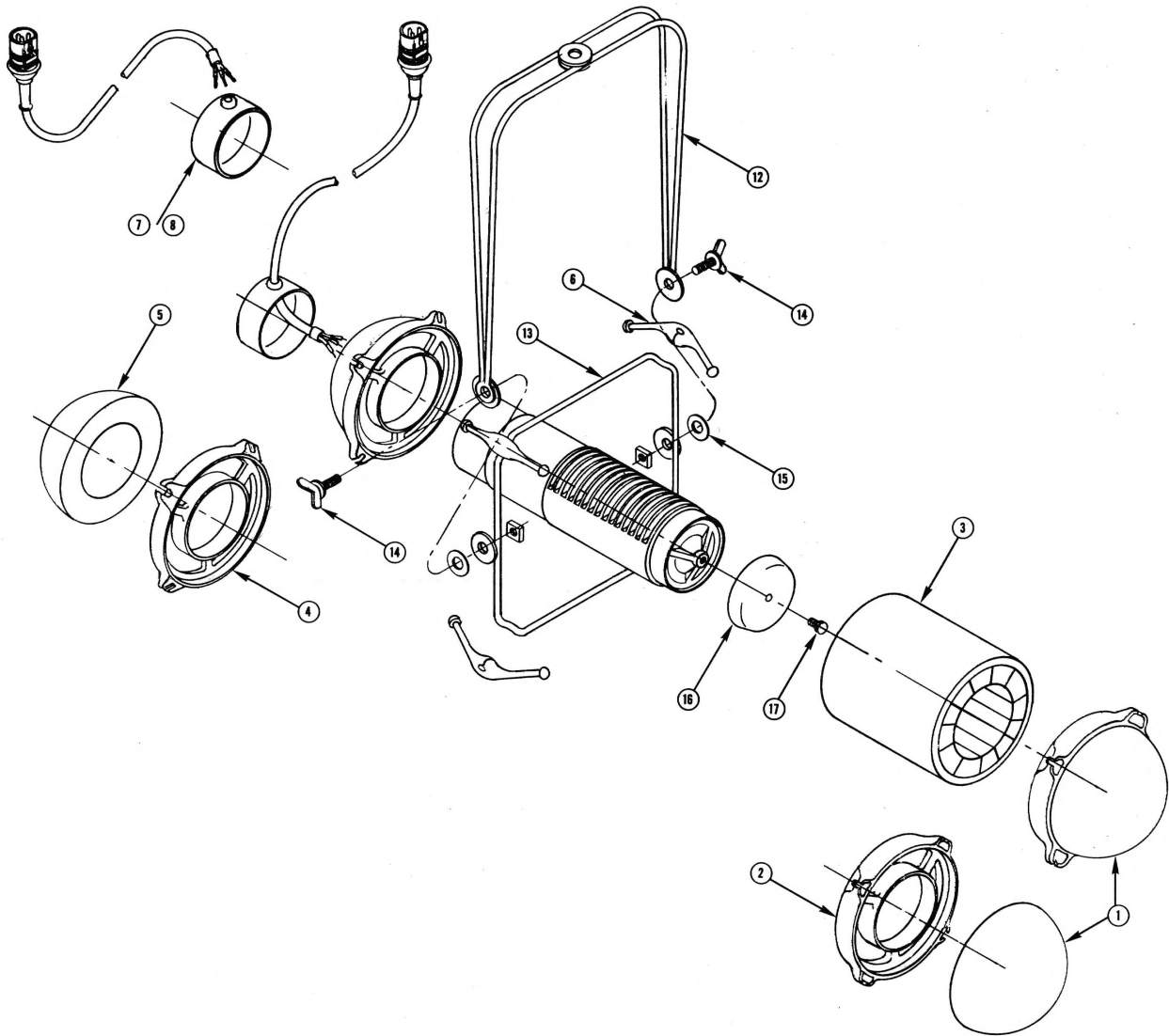

Figure 5 - Programming Panel (keyed to Fig. 1)

## REPLACEMENT PARTS

DESCRIPTION	PART NO.
1. Wind Screen - front section	75872
2. Shock Ring - inner	A75556 - EE
3. Wind Screen mid section	75871
4. Shock Ring - inner (Same as #2)	A75556 - EE
5. Wind Screen - rear	75870
6. Cord - suspension	75610
7. Filter Cap Subassembly	83471
8. Filter Cap Subassembly	83471
9. Nameplate	48345
10. Label	531395
11. Cable, Subassembly	83469
12. Bail	75557 - EE
13. Shock Ring - outer	75558 - EE
14. Bolt, wing 1/4 - 20	20743 - EE
15. Washer, friction	38309
16. Screen, grille	72302 - EE
17. Screw, Gulmite	6306 - CL



---

# Electro-Voice 668 Datasheet

---

 [001.jpg](#)

**001**

 [002.jpg](#)

**002**

 [003.jpg](#)

**003**

 [004.jpg](#)

**004**

[zurück](#)