

Electro-Voice®

a MARK IV company

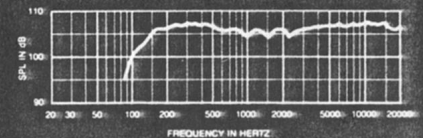

FIGURE 1
Axial Frequency Response using
Recommended Crossover, Equalization
and Time Delay
1 Watt/1 Meter into MB Section

MTH-4 Series

Manifold Technology™

Midbass/Midrange/High-Frequency
Sound Reinforcement System

SPECIFICATIONS

Frequency Response, Measured in Farfield Calculated to One Meter on Axis, Swept One-Third-Octave Pink Noise, Anechoic Environment (see Figure 1):

150-20,000 Hz

Recommended Crossover Frequencies:
160 Hz, 1,600 Hz, 8,000 Hz

Efficiency:
25%

Long-Term Average Power Handling Capacity per EIA Standard RS-426A (see Power Handling section),

MB/MF/HF: 1,200/240/100 watts

Short-Term Power Handling Capacity (10 milliseconds),

MB/MF/HF: 4,800/960/400 watts

Maximum Long-Term Average Midband Acoustic Output:

360 watts

Sound Pressure Level at One Meter, Indicated Input Power, Anechoic Environment, Band-Limited Pink-Noise Signal,

MB/MF/HF,

1/1/1 Watt: 107/113/108 dB

1,200/240/100 Watts: 138/137/128 dB

4,800/960/400 Watts: 144/143/134 dB

Dispersion Angle Included by 6-dB-Down Points on Polar Responses, Indicated

One-Third-Octave Bands of Pink Noise,
600-20,000 Hz Horizontal (see Figure 3):
60° (+10°, -8°)

600-20,000 Hz Vertical (see Figure 3):
40° (+15°, -5°)

Directivity Factor R_{θ} (Q), 600-20,000-Hz Median (see Figure 4):

23.3 (+6.3, -8.0)

Directivity Index D_i , 600-20,000-Hz Median (see Figure 4):

13.6 dB (+1.1 dB, -1.7 dB)

Distortion, 130 dB SPL at 1 Meter, Shaped Spectrum (see Figure 5),
Second Harmonic,

200 Hz: 1.1%

1,000 Hz: 1.0%

3,000 Hz: 4.0%

10,000 Hz: 2.7%

Distortion, 130 dB SPL at 1 Meter, Shaped Spectrum (see Figure 5),
Third Harmonic,

200 Hz: 0.5%

1,000 Hz: 3.0%

3,000 Hz: 0.9%

10,000 Hz: 3.1%

Transducer Complement,

MB: Four DL10X

MF: Four modified DH2

HF: Four DH2010

Impedance (MB wired in paralleled pairs;
MF/HF wired in single parallel-series
combinations, see Figure 7),

Nominal, MB/MF/HF:

4-ohms (pair)/8 ohms/8 ohms

Minimum, MB/MF/HF:

4-ohms (pair)/6 ohms/7 ohms

Input Connections:

Two Cannon EP-4-14

Enclosure Materials,

Structural, All Versions:

14-ply birch plywood

Finish,

MTH-4, MTH-4F:

Black Ozite Super TNT carpet

MTH-4P, MTH-4PF:

Black textured paint

Hanging (MTH-4F and MTH-4PF only):

Two-point flying system

(tracks accept Aeroquip 32102 fittings)

Dimensions,

Height: 91.4 cm (36.0 in.)

Width: 91.4 cm (36.0 in.)

Depth: 76.2 cm (30.0 in.)

Net Weight:

166 kg (367 lb)

Shipping Weight:

187 kg (415 lb)

DESCRIPTION

The Electro-Voice MTH-4 Manifold Technology™ midbass/midfrequency/high-frequency system was designed for high-level concert sound reinforcement in touring sound and permanent installation applications. The MTH-4 is a three-way, active, horn-loaded system utilizing four drivers in each frequency band for a total of twelve drivers in a remarkably small enclosure.

The midbass section operates over the range of 150-2,000 Hz and utilizes four DL10X 10-inch drivers. The extended upper-end response is achieved by using a proprietary phase plug (patent pending). An aperiodic enhancer, this phase plug makes use of the fact that at higher frequencies, only the apex area of the cone near the voice coil is in motion and automatically adjusts acoustic loading to maximize high-frequency output. The output of the four drivers is summed through a unique midbass manifold (patent pending) and fed into an integral 60° x 40° constant-directivity horn. The result is uniform coverage and an exceptionally natural sound throughout the entire vocal range.

The midrange section contains four modified DH2 compression drivers manifolded onto a single HP64 60° x 40° constant-directivity horn. The drivers come in a modified package that facilitates manifolding, but maintain the same high performance and reliability by utilizing the same titanium diaphragm and motor assembly. The outputs

HORIZONTAL
Level Adjusted

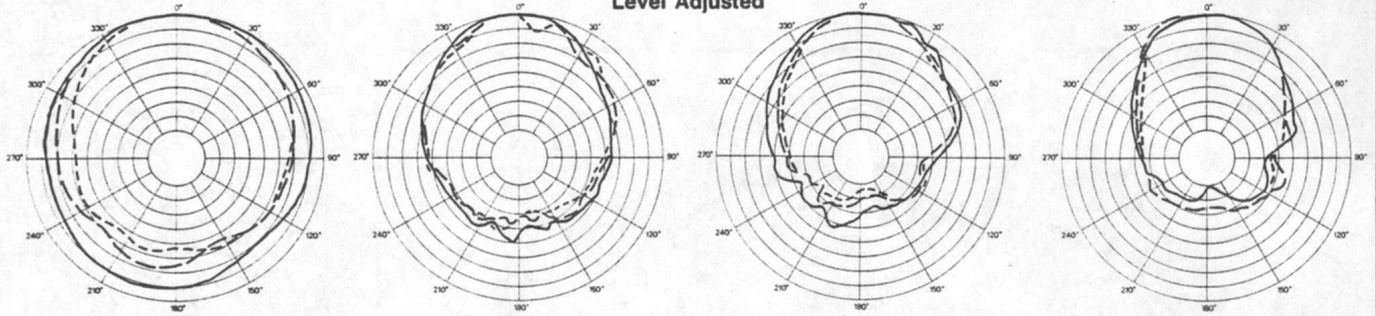

160 Hz ——— 630 Hz ——— 2,500 Hz ——— 10,000 Hz ———
 250 Hz - - - 1,000 Hz - - - 4,000 Hz - - - 16,000 Hz - - -
 400 Hz - - - 1,600 Hz - - - 6,300 Hz - - - 20,000 Hz - - -

VERTICAL
Level Adjusted

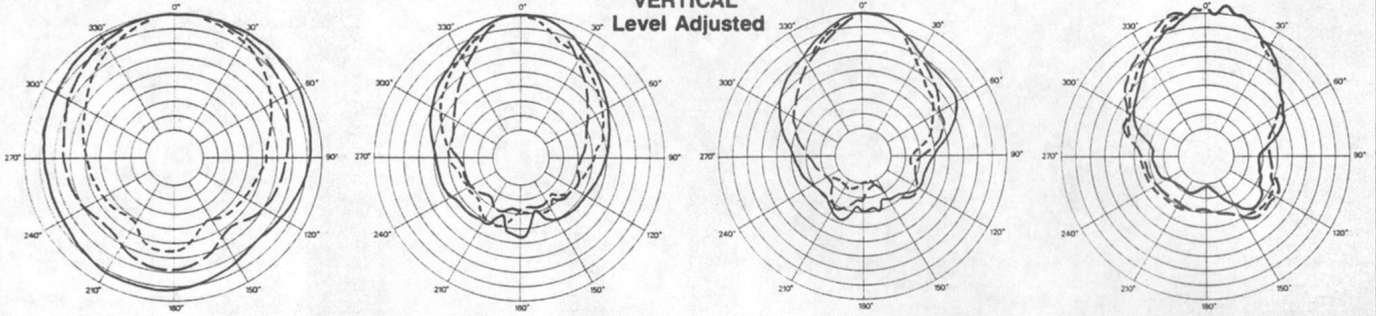

5 dB per Division

FIGURE 2
MTH-4 Polar Response
(1/3-octave, 4 volts at 20 feet)

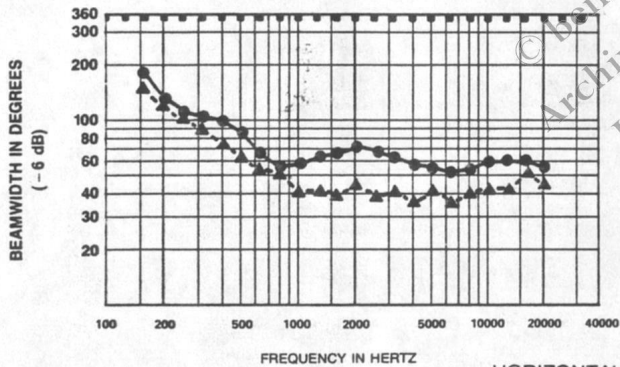

FIGURE 3
Beamwidth vs. Frequency

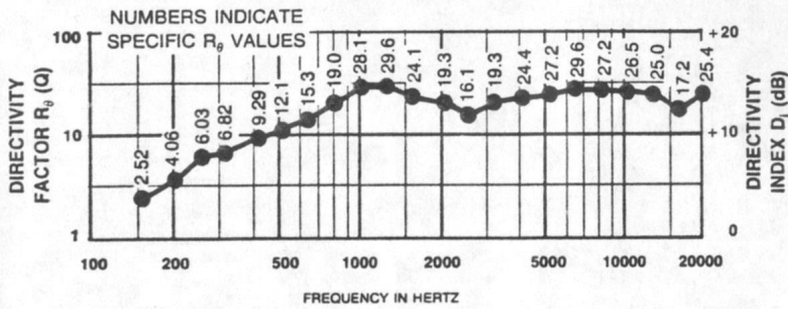

FIGURE 4
MTH-4 Directivity Factor and
Directivity Index vs. Frequency

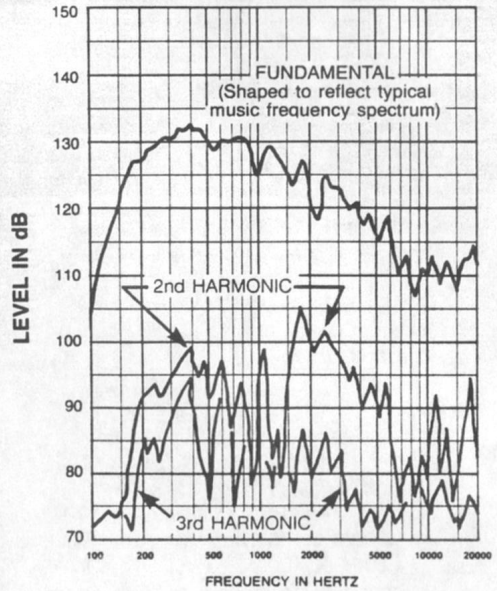

FIGURE 5
MTH-4 Harmonic Distortion
(130 dB SPL/1 meter using typical
music frequency spectrum)

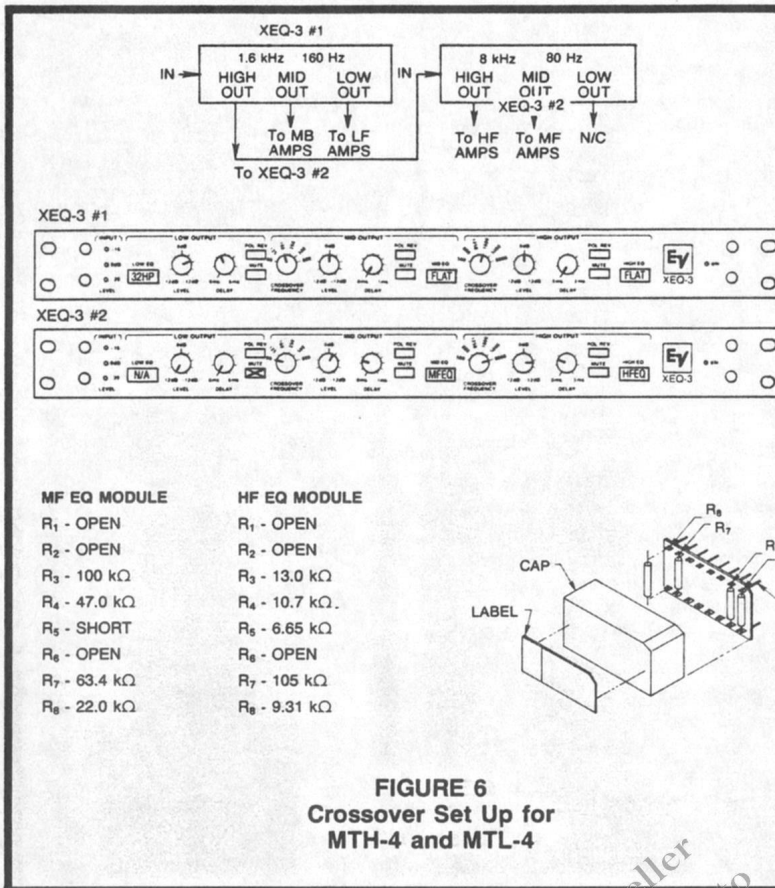

FIGURE 6
Crossover Set Up for
MTH-4 and MTL-4

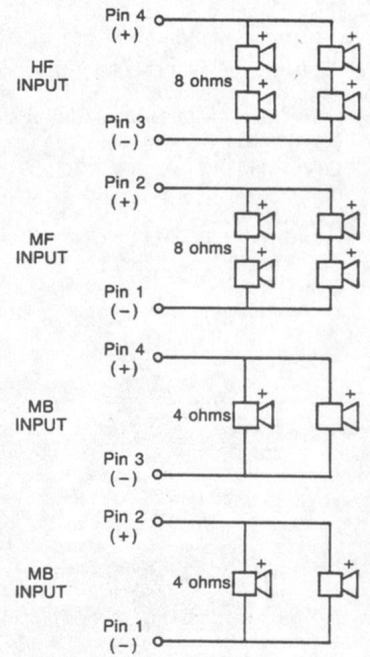

FIGURE 7
MTH-4 Wiring Configuration

of the four drivers are combined by a manifold device (patent pending) that achieves total summation of acoustic power up to 20,000 Hz without phase cancellations. The output of the manifold is fed into a small flat-front constant-directivity horn, the HP64, geometrically optimized for performance from 1,500 Hz to 20,000 Hz. The HP64 design is based on the EV HP horn series (patent pending) that features integral fiberglass-and-zinc construction for exceptional strength. The HP series also features beamwidth control vanes—special waveguides in the horn throat—that correct the very-high-frequency dispersion anomalies of other 2-inch-throat horns.

The high-frequency section employs four DH2010 compression drivers that feature a titanium diaphragm and a unique convex-drive Time Path™ phasing plug structure (U.S. Patent #4,525,604) for smooth and extended high-frequency performance to 20,000 Hz. The tweeter drivers are mounted on a high-frequency manifold and 60° x 40° constant-directivity horn identical to that used for the midrange. The use of identical horns and manifolds results in equal acoustic path lengths for the two sections.

Designed to survive the rigors of the road, all versions of the MTH-4 are constructed of 14-ply birch plywood. The MTH-4 and MTH-4F (flying option) are covered with black Ozite Super TNT carpeting, the most rugged in the industry. The MTH-4F flying option incorporates a unique two-point flying

system (see Hanging section). For permanent installations, the MTH-4P and MTH-4PF are available, finished with black textured paint. All versions feature a black nylon cloth grille.

APPLICATIONS

The MTH-4 is ideal for any professional touring or installation application requiring midbass, midrange and high-frequency reproduction at high sound pressure levels with low distortion. Manifold Technology maximizes the acoustic output per bulk volume and frontal area of the enclosure, enabling more compact systems and arrays than would be obtainable with conventional sound reinforcement enclosure designs. Additionally, because of its square-front design, the MTH-4 may be stacked or hung so that the 60° x 40° coverage pattern is oriented horizontally or vertically.

The dimensions of the MTH-4 were chosen for efficient truck pack and high-density array design. The cabinets may be stacked three high and three wide in a standard tractor trailer allowing for nearly 14,000 watts of sound system to be accommodated in only three feet of truck floor length. Careful attention was paid to details to provide both the touring company and the sound contractor with a convenient and time-saving professional sound reinforcement package.

For full-range applications the MTH-4 may be combined with the MTL-4 low-frequency sound reinforcement system. Designed as an

integrated package, both systems have identical external dimensions and matching hardware.

FREQUENCY RESPONSE

The MTH-4 frequency response was measured on axis in the farfield in an anechoic environment using a swept one-third-octave input and calculated to a one meter equivalent distance by using the inverse-square law. The system was set up using the recommended crossover, equalization and time delay (see Crossover, EQ and Time Delay section) with one watt of power being delivered to the midbass section (see Figure 1).

DIRECTIVITY

The polar response of the MTH-4 speaker system at selected 1/3-octave bandwidths is shown in Figure 2. These polar responses were measured in an anechoic environment at 20 feet using 1/3-octave pink noise inputs and the recommended crossover, equalization and time delay (see Crossover, EQ and Time Delay section). The frequencies selected are fully representative of the polar response of the system. Beamwidth of the system utilizing the complete 1/3-octave polar data is shown in Figure 3. R_θ (Q) and directivity index (D_i) are plotted in Figure 4.

DISTORTION

Using the recommended crossover, equalization and time delay (see Crossover, EQ and Time Delay section), distortion for the MTH-4 speaker system was measured in the farfield

with an input power that would result in a sound pressure level of 130 dB at one meter. A frequency spectrum typical of contemporary close-miked rock music was employed. Plots of second- and third-order harmonic distortion are shown in Figure 5.

POWER HANDLING CAPACITY

To our knowledge, Electro-Voice was the first U.S. manufacturer to develop and publish a power test closely related to real-life conditions. First, we use a random noise input signal because it contains many frequencies simultaneously, just like real voice or instrument program. Second, our signal contains more energy at extremely high and low frequencies than typical actual program, adding an extra measure of reliability. Third, the test signal includes not only the overall "long-term average" or "continuous" level — which our ears interpret as loudness — but also short-duration peaks which are many times higher than the average, just like actual program. The long-term average level stresses the speaker thermally (heat). The instantaneous peaks test mechanical reliability (cone and diaphragm excursion). Note that the sine-wave test signals sometimes used have a much less demanding peak value relative to their average level. In actual use, long-term average levels exist from several seconds on up, but we apply the long-term average for several hours, adding another extra measure of reliability.

Specifically, the MTH-4 is designed to withstand the power test described in EIA Standard RS-426A. The EIA test spectrum is applied for eight hours. To obtain the spectrum, the output of a white noise generator (white noise is a particular type of random noise with equal energy per bandwidth in Hz) is fed to a shaping filter with 6-dB-per-octave slopes below 40 Hz and above 318 Hz. When measured with the usual constant-percentage analyzer (one-third-octave), this shaping filter produces a spectrum whose 3-dB-down points are at 100 Hz and 1,200 Hz with a 3-dB-per-octave slope above 1,200 Hz. This shaped signal is then divided into the three frequency bands of operation using the recommended crossover, equalization and time delay (see Crossover, EQ and Time Delay section). The midbass amplifier is set with continuous power at 600 watts into each of the 3.45-ohm EIA-equivalent-impedance inputs (45.5 volts true RMS), resulting in a total of 1,200 watts being delivered to the midbass section. Amplifier clipping sets instantaneous peaks at 6 dB above the continuous power, or 4,800 watts peak (91.0 volts per input). The midrange amplifier is set with continuous power at 240 watts into the 5.18-ohm EIA-equivalent-impedance input (35.3 volts true RMS), with amplifier clipping setting instantaneous peaks at 960 watts (70.6 volts true RMS). The high-frequency amplifier is set with continuous power at 100 watts into the 5.75-ohm EIA-equivalent-impedance input (24.0 volts true RMS), with amplifier clipping setting instantaneous peaks at 400 watts (48.0 volts true RMS). This procedure provides a rigorous test of both thermal and mechanical failure modes.

CROSSOVER, EQ AND TIME DELAY

The usable frequency ranges of the individual sections of the MTH-4 are 150-2,000 Hz for the midbass, 1,200-8,000 Hz

for the midrange and 6,000-20,000 Hz for the high-frequency band. Minimum crossover slopes of 12-dB-per-octave are recommended. Low-frequency protection capacitors are included in the midrange and high-frequency sections, with respective 3-dB-down points of 800 Hz and 4,000 Hz.

As with all horn/driver combinations that combine high overall efficiency with constant directivity, the horns and drivers used in the MTH-4 exhibit a high-frequency power-response rolloff. While the equalization of a constant-directivity horn/driver combination can be achieved with a conventional one-third-octave equalizer, the use of an Electro-Voice XEQ-3 crossover/equalizer is recommended. This way, the broad-band equalization required by the horn/driver combination is supplied by the crossover/equalizer network, and the one-third-octave equalizer can be devoted to correcting the more subtle room- and array-related response anomalies.

For maximum performance of the MTH-4, a pair of XEQ-3 crossover/equalizers is recommended to obtain optimal crossover frequencies of 160 Hz, 1,600 Hz and 8,000 Hz, utilizing Linkwitz-Riley 24-dB-per-octave filters and time-delay equalization to achieve zero lobing error. The XEQ-3's will also provide accurate compensation equalization (through the use of custom EQ modules), enabling the MTH-4 to achieve the performance presented herein. Figure 6 illustrates the proper set up for optimal performance of the MTH-4 using two XEQ-3 crossover/equalizers and an MTL-4 low-frequency loudspeaker system for full-range reproduction. (Included are all front-panel settings (assuming equal-gain amplifiers) and custom EQ module construction information.

CONNECTION

Electrical connections are made on the back of the MTH-4 via two 4-pin connectors. The midbass section has four 8-ohm loudspeakers wired in paralleled pairs resulting in two 4-ohm loads accessed by one of the connectors. The midrange section has four 8-ohm drivers wired in a parallel-series arrangement resulting in one 8-ohm load accessed by two pins of the second connector. The high-frequency section also has four 8-ohm drivers wired in parallel-series with a resulting 8-ohm load accessed by the two remaining pins of the second connector. The connectors used are Cannon EP-4-14 (male), and the pin-out arrangement and wiring diagram are shown in Figure 7. The mating connector for the cable end is the Cannon EP-4-11-IC.

Cables, connectors and wiring accessories are being manufactured for the MT-4 system by Pro Co Sound, Inc., and Whirlwind Music Distributors, Inc. To find your local Pro Co or Whirlwind dealer, contact:

Pro Co Sound, Inc.
135 E. Kalamazoo Ave.
Kalamazoo, MI 49007

Whirlwind Music Distributors, Inc.
P.O. Box 1075
Rochester, NY 14603

HANGING

The MTH-4F (carpeted) and MTH-4PF (painted) are flying-option versions. In addition to a time savings in setup, their unique two-point flying system permits a wide range of angle adjustment and offers maximum flexibility in array design and implementation for both the sound touring company and the sound contractor.

Each enclosure side (not the top and bottom) has two tracks, placed to facilitate proper suspension and arraying. Tracks are placed to permit arraying the MTH-4 with the 60° coverage angle either horizontal or vertical. The surface of the tracks lies below the enclosure surface, to avoid any box-to-box interference problems during system transportation. The tracks mate with Aeroquip 32102 fittings.

FIELD REPLACEMENT

The MTH-4 was designed for expedient field service. A removable back panel allows access to the midbass drivers, while the removable horn/driver baffle board enables complete access to the compression drivers. In the case of compression driver failure, a diaphragm assembly replacement kit with instructions may be ordered under Electro-Voice part no. 81396XX for the midrange and part no. 81397XX for the high-frequency section, from the Electro-Voice Service Department in Buchanan, Michigan. If desired, the complete driver may be returned for service.

WARRANTY (Limited)

Electro-Voice Speakers and Speaker Systems (excluding active electronics) are guaranteed for five years from date of original purchase against malfunction due to defects in workmanship and materials. If such malfunction occurs, unit will be repaired or replaced (at our option) without charge for materials or labor if delivered prepaid to the proper Electro-Voice service facility. Unit will be returned prepaid. Warranty does not extend to finish, appearance items, burned coils, or malfunction due to abuse or operation under other than specified conditions, including cone and/or coil damage resulting from improperly designed enclosures, nor does it extend to incidental or consequential damages. Some states do not allow the exclusion or limitation of incidental or consequential damages, so the above exclusion may not apply to you. Repair by other than Electro-Voice or its authorized service agencies will void this guarantee. A list of authorized warranty service agencies is available from Electro-Voice, Inc., 600 Cecil Street, Buchanan, MI 49107 (AC/616-695-6831); Electro-Voice, Inc., 3810 148th Avenue N.E., Redmond, WA 98052 (AC/206-881-9555); and/or Electro-Voice West, 8234 Doe Avenue, Visalia, CA 93291 (AC/209-651-7777). This warranty gives you specific legal rights, and you may also have other rights which vary from state to state.

Service and repair address for this product: Electro-Voice, Inc., 600 Cecil Street, Buchanan, Michigan 49107.

Specifications subject to change without notice.



ELECTRO-VOICE, INC., 600 Cecil Street, Buchanan, Michigan 49107

MANUFACTURING PLANTS AT ■ BUCHANAN, MI ■ NEWPORT, TN ■ SEVIERVILLE, TN ■ REDMOND, WA ■ GANANOQUE, ONT
©Electro-Voice, Inc. 1986 ■ Litho in U.S.A. Part Number 530713—643

a MARK IV company