



PATRICIAN 800 - Contemporary

FEATURES

- Quadri-balanced system offers flattest, broadest obtainable response.
- Massive 30-inch foam-cone woofer extends clean bass below 20 cps., unequalled by any other system.
- Matched stereo companion, Stereon 850, duplicates performance of upper three Patrician drivers.



STEREOON 850 Contemporary

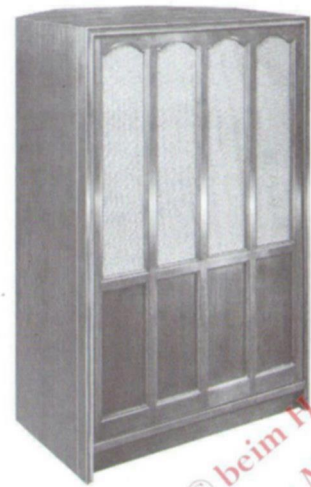

PATRICIAN 800 Traditional

SPECIFICATIONS

PATRICIAN 800

FREQUENCY RESPONSE: 15 to 23,000 cps
 NOMINAL IMPEDANCE: 16 ohms
 POWER HANDLING CAPACITY:
 PROGRAM: 70 watts
 CROSSOVER FREQUENCIES: 100, 800, 3500 cps
 DIMENSIONS: 51" h X 33" w X 26-7/16" d
 FINISHES AVAILABLE: Satin walnut, Mahogany, Cherry
 FURNITURE STYLES AVAILABLE: Traditional, Contemporary
 SHIPPING WEIGHT: 315 lbs.

STEREOON 850

FREQUENCY RESPONSE: 100 to 23,000 cps
 NOMINAL IMPEDANCE: 16 ohms
 POWER HANDLING CAPACITY:
 PROGRAM: 70 watts
 CROSSOVER FREQUENCIES: 100, 800, 3500 cps
 DIMENSIONS: 30" h X 21" w X 15" d
 FINISHES AVAILABLE: Walnut, Mahogany, and Cherry
 CABINET STYLES AVAILABLE: Traditional, Contemporary
 SHIPPING WEIGHT: 101 lbs.

The first Patrician, engineered by Electro-Voice more than a decade ago, aimed at—and achieved—nothing less than the finest sound reproduction obtainable. The new Patrician 800 continues in this perfectionist tradition, preserving unchallenged the reputation of being the world's finest device for converting electrical energy into sound. An exquisitely-balanced four-way system, it successfully extends sound reproduction, without coloration or distortion, to the upper and lower limits of audibility—and beyond.

The Patrician's capacity for breath-taking realism in bass reproduction is made possible by its 30-inch foam-cone woofer, the largest successful driver ever produced. Smaller and less expensive systems may reach very low frequencies, but only with a substantial compromise in efficiency. Even with the maximum electrical input that any smaller woofer can handle, the net acoustical power available at low frequencies falls far short of that required for the most effective reproduction of music. Inherent in this fact is the justification for the Patrician 800: it is this combination of extended bass range and substantial acoustic power capabilities at the lowest frequencies, with good efficiency, that is the main reason for—and vindication of—the size and cost of the Patrician 800.

Michael Otto

© beim Hersteller Archiv Michael Otto

This unparalleled might in the deepest bass region is a thing of fascination in itself. The woofer system is highly efficient in the 35- to 40-cycle region, where most speakers have already become ineffective, and then continues to respond down to 20 cycles and lower with awesome impressiveness.

But this is only one aspect of the Patrician's truly fabulous overall quality. Superbly clean and controlled mid-bass is achieved by the use of a very low, first crossover frequency of 100 cycles, and with full 12 db per octave rates of attenuation on each side of this crossover. The deluxe heavy duty SP12D mid-bass driver is housed in a separate liberally-padded enclosure, which also contributes to uniform and uncolored response in this range. Treble frequencies above 800 cycles are handled by the spectacular T250 driver. Used with the standard 8HD diffraction horn, the high magnetic damping and generous capabilities of this driver afford critically smooth and distortionless treble response. The clarity of the treble range blends imperceptibly into the shimmering precision supplied by the brilliant and reliable T350, which extends the response to an upper limit of 23,000 cycles.

The Patrician 800 is available in traditional and contemporary furniture styles, solidly constructed from selected woods, one-inch thick throughout, and exquisitely finished in hand-rubbed walnut, mahogany or cherry. To take fullest advantage of the inherently superior acoustical loading at low frequencies brought about by the laws of sound reflection in rectangular rooms, and by radiation into a solid angle, this enclosure is to be used in the corner, since the fundamental concept of the Patrician 800 is that it be the finest possible loudspeaker system. However, one of the dividends of the extremely large woofer and the type of enclosure necessarily associated with it is that it is much less critical of placement than many corner systems. Its performance remains amazingly good when located along the wall or elsewhere in the room. Moreover, when placed in a corner, its orientation is not critical but may be adapted to meet the requirements of individual furniture arrangements and stereo systems. The internal design of the bass enclosure is entirely new and consists in essence of an airtight, ten cubic foot chamber behind the 30-inch woofer and a 10-1/2-inch straight axis horn, with a 275 square-inch throat area and 370 square-inch mouth area, leading from the front of the woofer into the corner of the room. The enclosure occupies only 5.5 square feet of floor space and its overall shape is such as to make it surprisingly easy to accommodate.

The Patrician 800 is one of the very few deluxe speaker systems which, asking more initially of

those who would own it, is truly able to give more satisfaction, proportionally, in return. The world's greatest loudspeaker is a fitting companion to the world's greatest music. Ownership of the Patrician 800 is an appropriate expression of devotion to the music you love best.

The Stereon 850 is a complementary speaker system specifically designed to permit the economical and space saving expansion of the Patrician 800 to stereophonic reproduction. It utilizes the mid-bass, treble, and very high frequency components of the Patrician 800 (SP12D, T250 with 8HD, and T350), with special 12 db per octave crossover network and level controls.

PLACEMENT

Any loudspeaker system, whether designed for corner or along the wall use, will usually deliver the smoothest, most extended bass response—and the best overall sound—when placed in a corner of the listening room. In this position, it uses to best effect, the standing waves and principles of sound reflection in addition to the horn loading provided by the flare of the walls themselves, meeting at the corner.

The Patrician 800 is amazingly effective in any location—even in the center of the room. Most important, its orientation in the corner is not rigidly determined, and its angle of placement may be adjusted for best stereo effect. Ideally, of course, it should be placed in a corner with the angular back surfaces approximately six inches from the wall.

AMPLIFIERS

Almost any reasonably good high-fidelity amplifier may be used with the Patrician 800. Because of its high efficiency, less amplifier power is needed than with smaller or less costly systems. The Patrician 800 will, however, handle the full music output of any quality amplifier currently available for home use. Ideally, an amplifier capable of 20 to 70 watts output with less than .1% to .5% harmonic distortion at any frequency above 20 cycles would be excellent. Amplifiers with high damping factors (between approximately 10 and 50) are recommended, and the Patrician 800 owner who is selecting an amplifier should devote careful attention to choosing one with quality components, and power and output transformers of generous size and weight.

CONNECTIONS

Connection of your Patrician 800 to the amplifier should be made with No. 18 or larger wire (common zip or lamp cord is good). If you wish to run the lead between the amplifier and the speaker more than 30 feet, or to run it behind a molding strip or

carpet, use 300-ohm TV twin lead. Connect it to the 16-ohm and Common taps of the amplifier. Be certain that these connections are secure. For monophonic operation, the two leads from the power amplifier are connected to the two terminals labeled "Input" on the Patrician 800. For proper phasing, be sure to run the lead from T1 on the Patrician 800 to the 16-ohm terminal on the amplifier, and from T2 to the Common terminal. All wire jumpers should be left in place, as indicated on the upper left-hand diagram on the escutcheon. In this diagram, the rectangular block labeled Patrician 800 represents the escutcheon of the Patrician 800; the 10 dots with lines between them represent the 10 binding posts with their wire jumpers.

LEVEL CONTROLS

The loudness of the mid-bass, treble, and very-high-frequency sections of the Patrician 800 may be individually adjusted by means of the level controls provided. The system is shipped with these controls set for laboratory-flat response and locked in place, but other settings may be used to accommodate individual preferences and room acoustics.

A simple way to adjust the very-high-frequency (Brilliance) control is to tune in a live FM broadcast and, with volume level equal to that of your own voice, adjust the control until the "S" and "T" sounds are no more prominent in the announcer's voice than they are in your own. This adjustment will usually prove satisfactory. Setting the high-frequency control too high will produce a "metallic" sound. Your best guide to setting the control properly is, of course, a familiarity with the sound of live music. Acoustically "hard" or "live" rooms will normally require a somewhat retarded setting of the Brilliance control to compensate for the greater amount of high-frequency reflections. In "soft" or "dead" rooms, with carpeting, draperies, and soft furniture, a more advanced setting of the high-frequency control will normally be required.

The mid-bass and treble control adjustments are somewhat less critical. Should a more perfect match to the room be necessary, simply slowly rotate the controls individually to suit your hearing.

STEREO OPERATION

Two Patrician 800's may be used in a conventional stereophonic array, with one system connected to the output terminals of the amplifier in each stereo channel. To check phasing in this type of system, feed monophonic source materials into both channels simultaneously and adjust the amplifier's stereo balance control so that the Patrician 800's are playing at equal loudness. Then stand at the point of convergence of the axes of the two speakers (midway between them and at a reasonable distance from them). If the stereo channels are properly

phased and balanced, the sound will seem to come from an imaginary speaker midway between them. If this effect cannot be obtained at any setting of the stereo balance control, the connection to one of the two Patrician 800's should be reversed. This is accomplished by reversing the connections at either the amplifier or speaker system, or by use of the phase switch on your amplifier if one is provided.

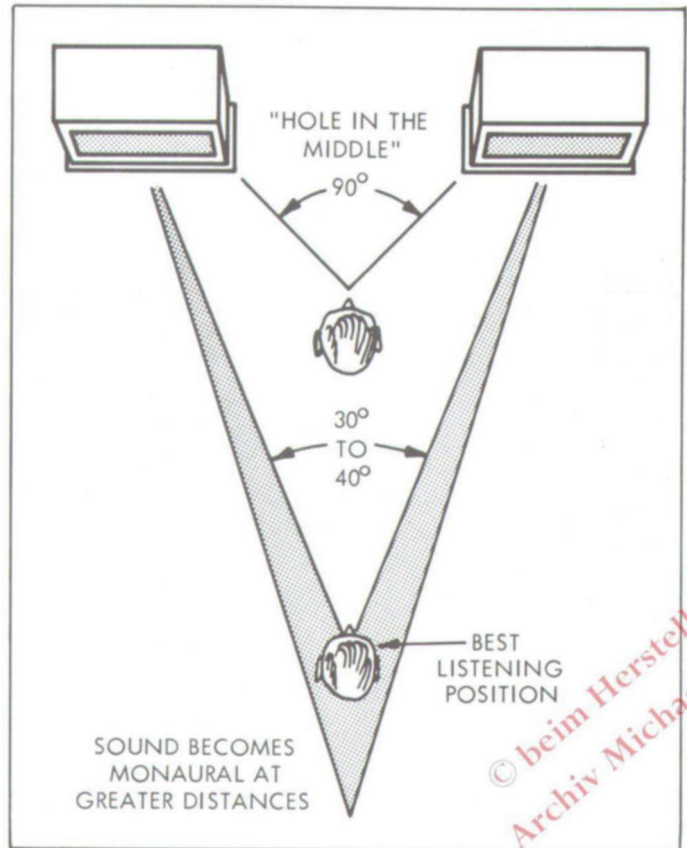
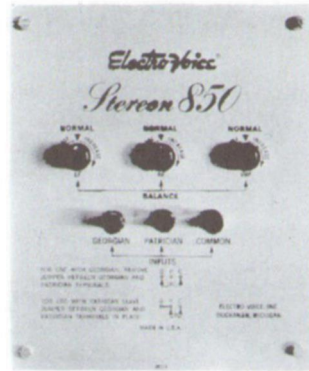
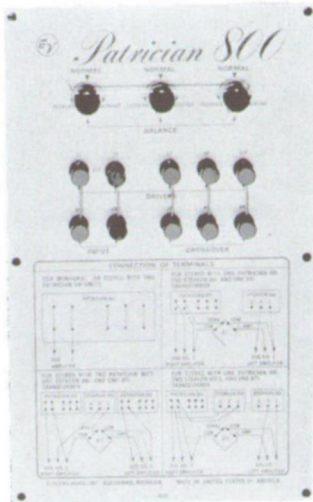

FIGURE 1-Placement for Stereo

When the system has thus been adjusted so that monophonic sound seems to come from the imaginary center source, well recorded stereo discs and tapes will be reproduced with startlingly precise stereo localization, and the overall sound quality will be magnificent at almost all listening locations in the room.

It is not necessary to employ two separate Patrician 800 systems for stereophonic reproduction, however, since the Stereon 850 may be used to permit the economical and space-saving expansion of a single Patrician 800 to stereophonic operation.

Specific wiring information for connecting the Patrician 800 in stereo arrangements is given on the escutcheon of the system itself. This information will be found to be self-explanatory. The rectangular blocks labeled "Patrician 800" and "Stereon 850" represent the escutcheons of the respective systems; the dots within these rectangular blocks are the binding posts on the escutcheon, and lines between these dots represent wire jumpers which are present on the system.



The Stereon 850 may be used in both two- and three-channel stereophonic systems and may be placed in any of a number of locations relative to the Patrician 800. Experiment will determine the arrangement most suitable to your own acoustical environment, using the basic test outlined for monophonic source materials described above. Where the two outside loudspeakers in the system must be separated by a great distance, it may be necessary to incorporate a third, center channel loudspeaker to eliminate a tendency toward exaggerated stereo separation.

CUSTOMER SERVICE

The Patrician 800 and Stereon 850 are packed to provide protection well in excess of shipping requirements of the Interstate Commerce Commission. If shipping damage does occur, contact the carrier, requesting its inspection and instructions, or the dealer from whom the unit was purchased. The identification number of your loudspeaker is noted on the warranty registration card. This number should be recorded and used in all correspondence regarding your system. The warranty registration card should be filled out and mailed to the factory within ten days after your purchase.

The Patrician 800 and Stereon 850 systems are guaranteed indefinitely against defects in original workmanship and materials. Should your system become damaged or develop faulty operation from unusual conditions of use, Electro-Voice maintains a complete Service Department to return equipment to factory-new condition. If attention becomes necessary, please write the Service Department, requesting return authorization and shipping instructions. When writing, please mention the make and model number of other components used in the system.

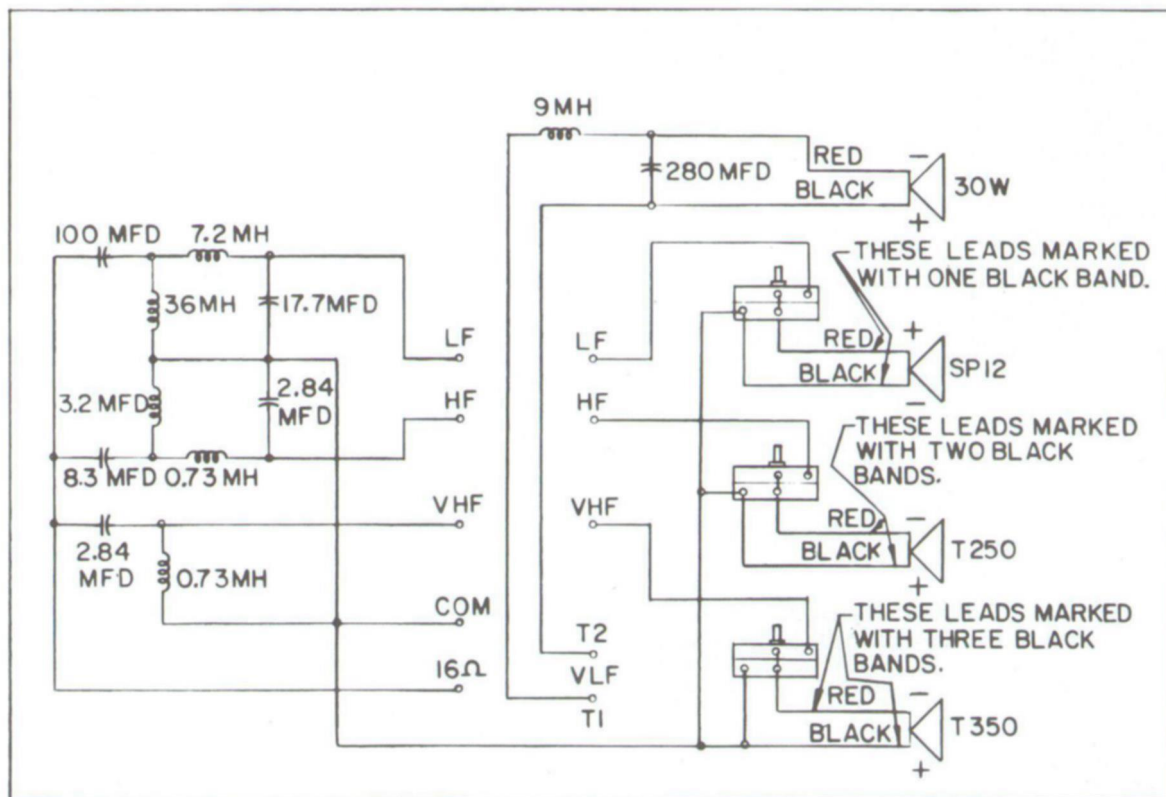

FIGURE 2 - Schematic Wiring Diagram