

Electro-Voice®

a MARK IV company

Model S-40 Compact Monitor

SPECIFICATIONS

Frequency Response, 1 Meter on Axis, Swept 1/3-Octave, Anechoic Environment ± 3 dB:

85-20,000 Hz

Usable Low-Frequency Limit (10-dB-down point):

65 Hz

Long-Term Average Power Handling Capacity per EIA Standard RS-426A

(see Power Handling Capacity section):

160 watts

Sound Pressure Level at 1 Meter, 1 Watt Input, Anechoic Environment, Band-Limited

Pink Noise Signal, 300 to 2,000 Hz:

85 dB

Dispersion Angle Included by 6-dB-Down Points on Polar Responses, Indicated One-Third-Octave Bands of Pink Noise, Horizontal and Vertical,

1,500-10,000 Hz:

$100^\circ \pm 25^\circ$

Directivity Factor R_0 (Q), 1,500-20,000 Hz Median:

9.5 (+3.8 dB, -3.6 dB)

Directivity Index D_1 , 2,000-20,000 Hz Median:

9.8 dB (+3.8 dB, -3.6 dB)

Transducer Complement, High-Frequency:

2.5cm (1 inch) Tweeter

Low-Frequency:

13cm (5¼-in.) Woofer

Box Tuning Frequency:

75 Hz

Crossover Frequency:

3,500 Hz

Impedance, Nominal:

4 ohms

Minimum:

3.7 ohms

Enclosure Materials:

High impact polystyrene structural foam

Colors:

Black or white

Optional Accessories:

S-40MB Black, mounting bracket

S-40MB White, mounting bracket

Dimensions:

24.9 cm (9.8 in.) high,

17.8 cm (7.0 in.) wide,

15.0 cm (5.9 in.) deep

Net Weight (Each):

2.6 kg (5.7 lb)

Shipping Weight (Pair):

5.7 kg (12.7 lb)

DESCRIPTION

The Electro-Voice S-40 is an extremely compact high-performance monitor loudspeaker system. It is ideally suited for indoor or outdoor applications requiring high-quality sound reproduction. As a near-field monitor in control rooms or broadcast studios, or as a foreground or background loudspeaker in restaurants and clubs, the S-40 is the choice of professional users. Its high power handling also makes the S-40 an ideal loudspeaker for nearfield monitoring in live performance situations. Threaded inserts in the cabinet in combination with the optional mounting hardware provide a flexible mounting system for virtually any application.

The low-frequency section is a 5¼-in. direct-radiating woofer with a polypropylene cone installed in an optimally vented high-impact polystyrene enclosure. This combination produces an exceptionally extended bass response with relatively high efficiency for an

extremely small enclosure. The use of plastic materials for the enclosure and cone allow the loudspeaker system to be used in high-humidity environments.

The high-frequency section is a 1-in. direct-radiating soft dome tweeter. The tweeter is ferro-fluid cooled and uses flexible tinsel lead wires to prevent thermal or mechanical failure. These features in addition to the large magnetic system make this the most rugged tweeter ever used in a system this size.

These high quality components will provide years of listening pleasure when driven at reasonable levels. However, sometimes loudspeakers are accidentally over-driven, causing the drive units to fail. To prevent against this, EV engineers have incorporated independent woofer and tweeter protection circuits in the S-40. These circuits will automatically reduce the power being delivered to the drivers if their threshold is exceeded, greatly reducing the possibility of driver failure.

Both drivers feature low-flux-leakage designs enabling the speaker to be used in close proximity to video monitors. For very critical video monitoring applications, a minimum distance of four inches from the edge of the loudspeaker to the edge of the CRT is recommended.

FREQUENCY RESPONSE

The combination of 5¼-in. woofer, 1-inch tweeter and optimized crossover result in the wide and smooth frequency response shown in Figure 1. This response was measured at 1 meter, using a 2 Volt (1

*© beim Hersteller
Archiv Michael-Otto*

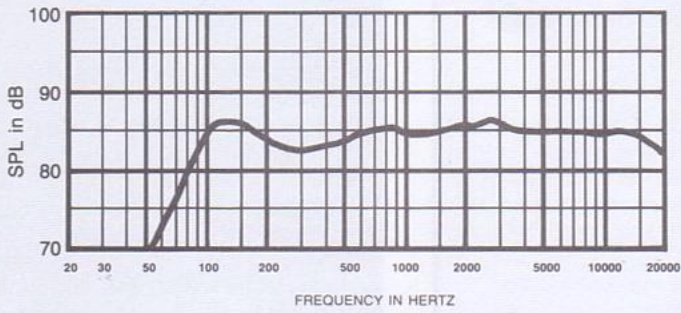
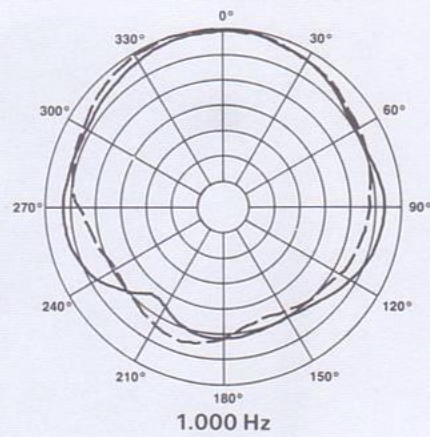
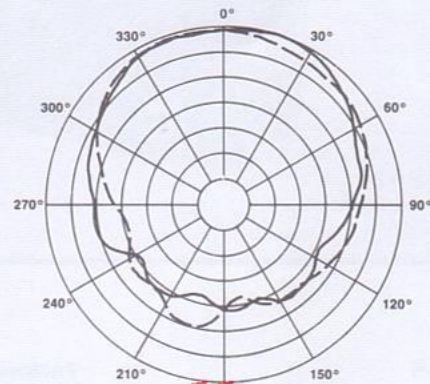

FIGURE — 1
Axial Frequency Response



1.000 Hz



2.000 Hz



4.000 Hz

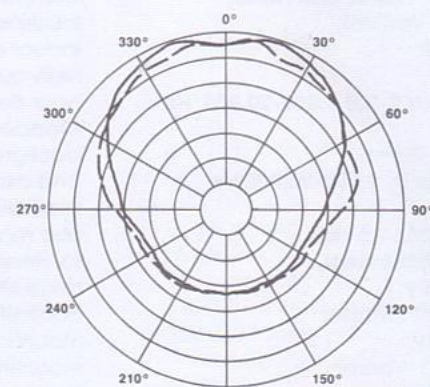

8,000 Hz Horizontal ——— Vertical - - -

FIGURE — 4
Polar Response

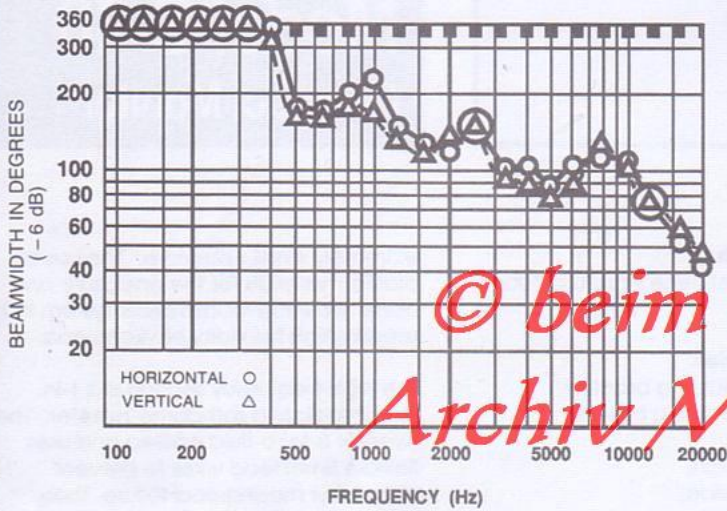

FIGURE — 2
Beamwidth vs. Frequency

*© beim Hersteller
Archiv Michael-Otto*

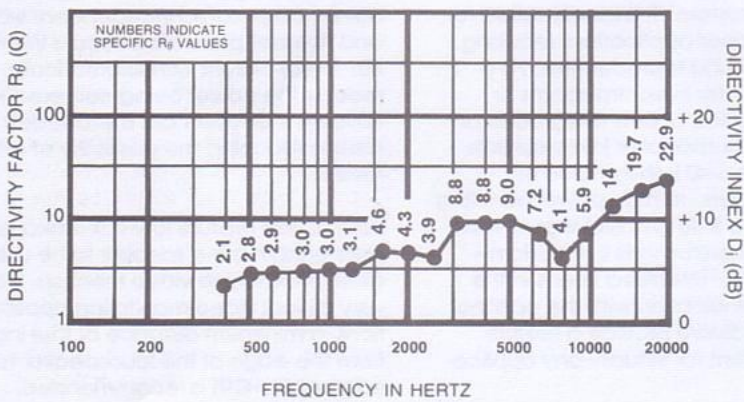

FIGURE — 3
Directivity vs. Frequency
Whole Space (anechoic)

DIRECTIVITY FACTOR R_{θ} (Q)

DIRECTIVITY INDEX D_i (dB)

NUMBERS INDICATE SPECIFIC R_{θ} VALUES

FIGURE — 3
Directivity vs. Frequency
Whole Space (anechoic)

watt) input in an anechoic chamber. The response is 1/3-octave averaged and no external equalization was used.

DIRECTIVITY

The polar response of the S-40 speaker system at selected 1/3-octave bandwidths is shown in Figure 4. These polar responses were measured in an anechoic environment at 10 feet using 1/3-octave pink noise inputs. The frequencies selected are fully representative of the polar response of the system. Beamwidth of the system utilizing the complete 1/3-octave polar data is shown in Figure 2. R_p (Q) and directivity index (D) are plotted in Figure 3.

POWER HANDLING CAPACITY

To our knowledge, Electro-Voice was the first U.S. manufacturer to develop and publish a power test closely related to real-life conditions. First, we use a random noise input signal because it contains many frequencies simultaneously, just like real voice or instrument program. Second, our signal contains more energy at extremely high and low frequencies than typical actual program, adding an extra measure of reliability. Third, the test signal includes not only the overall "long-term average" or "continuous" level - which our ears interpret as loudness - but also short-duration peaks which are many times higher than the average, just like the actual program. The long-term average level stresses the speaker thermally (heat). The instantaneous peaks test mechanical reliability (cone and diaphragm excursion). Note that the sine wave test signals sometimes used have a much less demanding peak value relative to their average level. In actual use, long-term average levels exist from several seconds on up, but we apply the long-term average for several hours, adding another extra measure of reliability.

Specifically, the S-40 is designed to withstand the power test described in the revised EIA Standard RS-426A. The EIA test spectrum is applied for eight hours. To obtain the spectrum, the output of a white noise generator (white noise is a particular type of random noise with equal energy per bandwidth in Hz) is fed to a shaping filter with 6-dB-per octave slopes below 40 Hz and above 318 Hz. When measured with the usual constant-percentage bandwidth analyzer (one-third octave), this shaping filter produces a spectrum whose 3-dB-down points are at 100 Hz and 1200 Hz with a 3-dB-per octave slope above 1200 Hz. This shaped signal is sent to the power amplifier with the continuous power set at 160 watts into the 3.2 ohms EIA equivalent impedance, (22.6 volts true RMS). Amplifier clipping sets instantane-

ous peaks at 6 dB above the continuous power, or 640 watts peak (45.2 volts peak). This procedure provides a rigorous test of both thermal and mechanical failure modes.

PROTECTION CIRCUITRY

Both the woofer and the tweeter employ independent protection circuits to prevent against accidental overdrive and improve system reliability. In the woofer circuit, a solid state self-resetting switch is activated once the safe level to the woofer is exceeded (approximately 60 watts). This switch then inserts a high positive current coefficient resistor (HPCCR) in series with the woofer. The resistance of the HPCCR increases as the drive level to the woofer increases and limits the power being delivered to the woofer. The HPCCR is similar to a lamp and will produce light that is visible thru the port when activated. This is an indication to reduce the gain of the power amp if output compression is to be avoided. The maximum acoustic output is achieved just before the protection circuit is activated.

The tweeter protection circuit behaves in a similar manner, except a fixed resistor is used in place of the HPCCR which attenuates the power to the tweeter by approximately 6 dB.

INSTALLATION NOTES

On the back of the S-40 are two 1/4-20" threaded inserts. These are intended to be used with mounting systems which have 2-3/8" mounting centers, such as the Omnimount Systems Series 25.

A U-type bracket, the S-40MB is also available. This will allow the S-40 to be mounted on walls or ceilings. A microphone stand adaptor is also included. Complete mounting instructions are included with the S-40MB.

Care should be taken to ensure that the chosen fixing point is strong enough to support the S-40. Care should also be taken to ensure that the S-40 is not exposed to direct precipitation.

If the speaker system is not used with one of the mounting brackets, such as on a bookshelf, then the rubber feet that are included with the S-40 should be attached to the speaker. If the speaker is placed on the bottom side, then a rubber foot should be attached to each of the two rear corners only. This will compensate for the 3° draft that is molded into the cabinet, and allows the baffle to sit perpendicular to the surface that the speaker is placed on. If the speaker is to be placed on its side, then a rubber foot should be attached to each of the four

corners. The nameplate that is attached to the grille may be rotated depending on which mounting orientation is used.

ARCHITECTS AND ENGINEERS SPECIFICATIONS

The loudspeaker shall be a two-way system consisting of a 13 cm (5 1/4-in.) low-frequency loudspeaker, 2.5 cm (1 inch) high-frequency loudspeaker and frequency dividing network installed in a vented enclosure. The dividing network crossover frequency shall be 3,500 Hz. The dividing network shall include protection circuits for both the low-frequency loudspeaker and the high-frequency loudspeaker. The loudspeaker system shall meet the following performance criteria: Power handling, 160 watts per EIA RS-426A. Frequency response, ± 3 dB from 85 Hz to 20 kHz. Pressure sensitivity, 85 dB SPL at one watt, 100 Hz to 10 kHz measured at a distance of one meter on axis. Impedance, 4 ohms nominal, 3.7 ohms minimum. The enclosure shall be molded of high impact polystyrene structural foam. The unit shall be 24.9 cm (9.8 inch) high, 17.8 cm (7.0 inch) wide, 15.0 cm (5.9 inch) deep. The loudspeaker system shall be the Electro-Voice model S-40.

WARRANTY (Limited) — Electro-Voice Speakers and Speaker Systems (excluding active electronics) are guaranteed for five years from date of original purchase against malfunction due to defects in workmanship and materials. If such malfunction occurs, unit will be repaired or replaced (at our option) without charge for materials or labor if delivered prepaid to the proper Electro-Voice service facility. Unit will be returned prepaid. Warranty does not extend to finish, appearance items, burned coils, or malfunction due to abuse or operation under other than specified conditions, including cone and/or coil damage resulting from improperly designed enclosures, nor does it extend to incidental or consequential damages. Some states do not allow the exclusion or limitation of incidental or consequential damages, so the above may not apply to you. Repair by other than Electro-Voice will void this guarantee. A list of authorized warranty service agencies is available from Electro-Voice, Inc., 600 Cecil Street, Buchanan, MI 49107 (AC/616-695-6831); Electro-Voice West, 8234 Doe Avenue, Visalia, CA 93291 (AC/209-651-7777). This warranty gives you specific legal rights which vary from state to state.

Service and repair address for this product: Electro-Voice, Inc., 600 Cecil Street, Buchanan, Michigan 49107.

Specifications subject to change without notice.

beim Hersteller
Archiv Michael Otto

*© beim Hersteller
Archiv Michael-Otto*



ELECTRO-VOICE, INC., 600 Cecil Street, Buchanan, Michigan 49107

MANUFACTURING PLANTS AT ■ BUCHANAN, MI ■ NEWPORT, TN ■ SEVIERVILLE, TN ■ OKLAHOMA CITY, OK ■ GANANOQUE, ONT.
©Electro-Voice, Inc. 1990 ■ Litho In U.S.A.

a MARK IV company

Part Number 531683-045