

SP8C SP12C SP15A Component Speakers

SPECIFICATIONS

Frequency Response in Recommended Vented Enclosure, 1 Meter on Axis, Half Space Anechoic Environment, Swept One-Third Octave Random Noise, ± 6 dB.

SP8C – 41-12,000 Hz
SP12C – 37-10,000 Hz
SP15A – 34-8,000 Hz

Low-Frequency Acoustic Power Output vs. Frequency, Small Signal, in Recommended Vented Enclosure

3-dB-Down	10-dB-Down
SP8C – 50 Hz	SP8C – 36 Hz
SP12C – 43 Hz	SP12C – 32 Hz
SP15A – 40 Hz	SP15A – 30 Hz

Sound Pressure Level at 1 Meter, 1 Watt into Nominal Impedance, Anechoic Environment, 300-2,000 Hz Average

SP8C – 95 dB
SP12C – 100 dB
SP15A – 103 dB

Power Handling Capacity,

Long-Term Average	Short-Term (10 ms)
SP8C – 25 watts	SP8C – 250 watts
SP12C – 25 watts	SP12C – 250 watts
SP15A – 50 watts	SP15A – 500 watts

Half-Space Reference Efficiency

SP8C – 0.9%
SP12C – 1.9%
SP15A – 3.5%

Amplifier Power Requirements, Continuous Average at 8 Ohms, for the Following Average Sound Pressure Levels, Mid-Band, in the Reverberant Field of a Typical Living room (R=200) with Peaks 10 dB above Average (Long-Term Average Power Capacity not to be exceeded)

Medium Level (85 dB SPL)
SP8C – 1.4 watt
SP12C – 0.66 watt
SP15A – 0.36 watt

Loud Level (95 dB SPL)
SP8C – 14.0 watts
SP12C – 6.6 watts
SP15A – 3.6 watts

Very Loud Level (105 dB SPL)
SP8C – 140 watts
SP12C – 66 watts
SP15A – 36 watts

Maximum Level
SP8C – 250 watts (107 dB)
SP12C – 250 watts (111 dB)
SP15A – 500 watts (116 dB)

Impedance

Nominal	Minimum
SP8C – 8 ohms	SP8C – 6.7 ohms
SP12C – 8 ohms	SP12C – 6.7 ohms
SP15A – 8 ohms	SP15A – 6.2 ohms

Thiele-Small Driver Parameters Nominal (see Special Note on Low-Frequency Performance section)

f_s
Free-Air Resonance Frequency
SP8C – 55 Hz
SP12C – 45 Hz
SP15A – 40 Hz

Q_{ES}
Electro-Magnetic Q at f_s
SP8C – 0.49
SP12C – 0.75
SP15A – 0.49

Q_{MS}
Mechanical Q at f_s
SP8C – 5.2
SP12C – 5.9
SP15A – 5.0

Q_{TS}
Total Q at f_s $\left[\frac{Q_{ES} \cdot Q_{MS}}{Q_{ES} + Q_{MS}} \right]$
SP8C – 0.45
SP12C – 0.67
SP15A – 0.45

V_{AS}
Volume of Air Having Same Acoustic Compliance as Driver Suspension
SP8C – 1.0 ft³
SP12C – 5.9 ft³
SP15A – 9.9 ft³

η_0
Half-Space Reference Efficiency
SP8C – 0.9%
SP12C – 1.9%
SP15A – 3.5%

V_D
Peak Displacement Volume of Diaphragm (= $S_D X_{max}$)
SP8C – 3.6 in³
SP12C – 10.8 ft³
SP15A – 25 in³

S_D
Effective Diaphragm Area
SP8C – 30 in²
SP12C – 83 in²
SP15A – 125 in²

X_{max}
Peak Linear Displacement of Diaphragm
SP8C – 0.12 in
SP12C – 0.13 in
SP15A – 0.20 in

$P_{E(max)}$
Thermally Limited Maximum Input Power
SP8C – 25 watts
SP12C – 25 watts
SP15A – 50 watts

Voice Coil Diameter
SP8C – 2 in
SP12C – 2 in
SP15A – 2-1/2 in

Magnet Weight
SP8C – 22 oz
SP12C – 22 oz
SP15A – 78 oz

Magnet Material – Ceramic

Dimensions
Overall Diameter
SP8C – 8-3/8 in
SP12C – 12-3/16 in
SP15A – 15-1/8 in

Overall Depth
SP8C – 4-3/4 in
SP12C – 6-1/8 in
SP15A – 7 in

Mounting Bolt Circle Diameter
SP8C – 7-5/8 in
SP12C – 11-9/16 in
SP15A – 14-9/16 in

Bolt Hole Diameter
9/32 in. in all units

Mounting Hole Number
SP8C – 4
SP12C – 8
SP15A – 8

Baffle Hole Diameter
Front Mounting
SP8C – 7-1/4 in
SP12C – 11-1/16 in
SP15A – 14 in

Rear Mounting
SP8C – 7-1/8 in
SP12C – 10-15/16 in
SP15A – 14-1/8 in

Net Weight
SP8C – 7 lb 2 oz
SP12C – 11 lb 12 oz
SP15A – 20 lb 2 oz

ELECTRO-VOICE COMPONENT SPEAKERS

Electro-Voice component speakers have traditionally provided the hobbyist and professional with the flexibility of custom installation as well as the opportunity for simple "building-block" system expansion and improvement. A comprehensive group of cone speakers, mid-frequency horns and drivers, horn tweeters, crossovers, and accessories is available. Additionally, all Electro-Voice component speakers offer conversion efficiencies substantially higher (3 to 8 dB) than typical "bookshelf" home speaker systems. This high efficiency is essential for most professional audio applications. In the home it permits accurate reproduction of the high sound levels of live music or, for more normal listening levels, the use of amazingly small amplifiers for satisfactory reproduction.

Electro-Voice cone speakers have now been thoroughly revised to reflect the latest knowledge of rational, optimized low-frequency speaker enclosure design. The result is a combination of extended low-distortion bass response, high efficiency, and modest cabinet size simply not available in other component speakers.

THE "SP" SERIES OF LOUDSPEAKERS

All of the SP series of Electro-Voice speakers have a rugged die-cast frame for maximum mechanical stability — much more so than the ordinary stamped frame speaker. All three units utilize a ceramic magnet with adequate magnetic assembly for maximum flux in the gap and consequent high efficiency. All three units incorporate a centrally mounted free-edge cone for improved high frequency propagation.

SP8C

The SP8C was designed for full-range use or as a woofer in a two or three way system. For an eight inch speaker it will provide remarkable performance in the bass range even in a small enclosure—only 1.2 cubic feet. The SP8C is ideal for a small or "starter" high-fidelity component speaker system. It will produce quite adequate sound pressure levels in environments such as the average living room.

SP12C

The SP12C was also designed for full range use or service only as a woofer. Due to the greater power handling capacity as well as the larger magnetic assembly, as compared to the SP8C, this unit will produce about 3.5 dB greater sound pressure than the smaller unit. In addition, it may be mounted in a larger box to provide response to half an octave lower frequency than the SP8C.

SP15A

This is the largest unit of the SP series. The 78 ounce magnet is the same as that used on the EVM18B high power music speaker. The voice coil is also the same and this combination leads to sound pressure levels about 8 dB above that produced by the SP8C. The SP15A can be used for excellent performance as a very low frequency woofer with essentially flat output down to about 32 Hz. There are very few musical instruments producing signal in this very low frequency range. Even with this performance the enclosure is not so large as to be unwelcome in the usual listening room. The voice coil of edge wound aluminum wire makes maximum use of the space within the magnetic gap. In addition, the light weight aluminum results in improved performance at higher frequencies for a speaker this large.

RECOMMENDED ENCLOSURES

The "SP" series of loudspeakers have been designed for mounting in vented boxes appropriate to the speaker characteristics. The use of a vented box with its tuned feature complements the performance of the speaker and provides maximum low-frequency performance consistent with size and speaker parameters. A vented box not only increases the low-frequency output but also reduces distortion for a given level.

In the following list we have attempted to choose a typical vented box size that best complements the SP8C, SP12C, and SP15A. Other vented box sizes and tunings are quite feasible and may give performance more suitable for a particular application. For further information please turn to the section of this sheet entitled: "Special Note on Low-Frequency Performance". If additional information is needed please ask for a copy of Bulletin 10B.

The low-frequency performance of these three vented enclosures is summarized below:

	SP8C	SP12C	SP15A
V_B	1.2 ft ³	5.5 ft ³	7.5 ft ³
f_B	47 Hz	43 Hz	40 Hz
f_3	50 Hz	43 Hz	40 Hz
f_{10}	36 Hz	32 Hz	30 Hz
f_{LL}	40 Hz	34 Hz	31 Hz

- V_B Net internal enclosure volume, not including volume displaced by bracing, port, or speaker. Variations of $\pm 10\%$ are acceptable.
- f_B Helmholtz resonance frequency of box-vent combination.
- f_3 Frequency at which the small signal (normal listening levels) acoustic power vs. frequency is down 3 dB relative to the mid-band output.
- f_{10} Frequency at which the small signal (normal listening levels) acoustic power vs. frequency is down 10 dB relative to the mid-band output.
- f_{LL} Usable low-frequency limit, the frequency at which the large-signal maximum acoustic power output vs. frequency is 10 dB below the maximum mid-band output (due to either thermal or displacement limitations).

Dimensions for the three recommended vented enclosures are shown below:

V_B Volume

- SP8C — 1.2 ft³
- SP12C — 5.5 ft³
- SP15A — 7.5 ft³

Inside Height (H)

- SP8C — 16-5/16 in
- SP12C — 27-1/4 in
- SP15A — 31-1/8 in

Inside Width (W)

- SP8C — 13 in
- SP12C — 21-1/2 in
- SP15A — 23-7/8 in

Inside Depth (D)

- SP8C — 10-5/16 in
- SP12C — 17-1/4 in
- SP15A — 19 in

Port Area (XY)

- SP8C — 4.3 in²
- SP12C — 30.4 in²
- SP15A — 33.1 in²

Port Depth (L)

- SP8C — 2.6 in
- SP12C — 3.4 in
- SP15A — 3.2 in

An outline drawing of a typical enclosure is shown below.

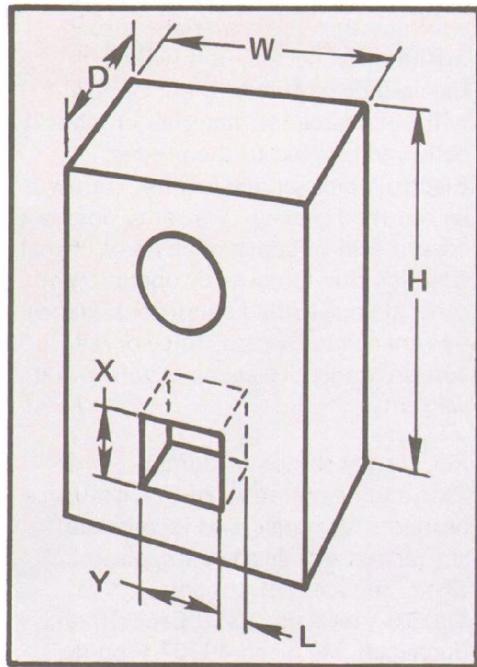

ENCLOSURE CONSTRUCTION

Speaker enclosures should be constructed of rigid materials such as void-free plywood or particle board. In general, 3/4-inch thick material is most satisfactory, although smaller enclosures (approximately 2 cubic feet and under) may be successfully constructed of 5/8-inch material. It is mandatory that the joints between the pieces of wood be strong and well sealed. Simple butt joints secured with wood screws or nails and white glue are very satisfactory. Removable panels should be secured with wood screws and weather stripping tape. For joints longer than about 3 feet, internal glue blocks may be appropriate. In the largest boxes—greater than about 6 cubic feet—bracing is usually required for the largest expanses of wood to prevent sympathetic vibrations from affecting overall system performance. Proper bracing technique splits a rectangular panel into two equal rectangles with the brace placed along the panel's longest dimension. Good bracing materials are 2 X 2 dimension lumber or 4-inch widths of 3/4-inch plywood, placed on edge. Three mutually adjacent inside surfaces of the enclosure (top, one side and rear) should be lined with a one to two inch thickness of glass wool or similar acoustic absorptive material to prevent internal reflections from affecting mid-frequency performance. No absorptive material should be placed over or within the port.

The location of the speaker on the mounting baffle is relatively unimportant but close-to-ear-level mounting will provide best mid- and high-frequency performance in the listening room. The enclosure's height, width, and depth may be changed as long as (1) the internal volume remains the same ($\pm 10\%$) and (2) extreme differences between any two dimensions are avoided. The required port area can be obtained by any convenient combination of width (Y) and height (X) as long as its long dimension is no more than five times the short dimension. The port is normally located on the front baffle board but may also be on any other box surface that has free access to the listening room. For most accurate box tuning the port should be no closer than several inches from the nearest adjacent enclosure wall. The port's proximity to the speaker is unimportant.

SPEAKER INSTALLATION AND HOOKUP

The "SP" series of speakers may be installed either on the inside or outer surface of the mounting baffle. As with all quality speakers, care should be taken in mounting if best results are to be obtained. Drill four or more mounting holes and cut the mounting baffle opening in accordance with the dimensions given in the Specifications section. To mount the speaker four or more carriage bolts with nuts and washers may be used. The SP8C will accommodate four 9/32 inch diameter bolts while the SP12A and SP15A will accommodate eight bolts of the same dimension. Wood screws are not recommended for mounting the speaker. Secure the speaker to the baffle board just tightly enough to compress the speaker gasket. Excessive tightening is not necessary since the compressible gasket will form a satisfactory seal with only nominal pressure.

To avoid any significant amplifier power loss in the speaker lines and undesirable change in low-frequency response, wire size must be properly chosen. 18 gauge stranded wire (commonly called lamp or "zip" cord) is satisfactory for lengths up to 38 feet limiting the loss in sound output to an insignificant 0.5 dB. If longer speaker lines are required use

progressively larger wire sizes: 16 gauge to 60 feet, 14 gauge to 96 feet and 12 gauge to 150 feet. These lengths assume an impedance level of one speaker or 8 ohms. Two speakers in parallel have an impedance of four ohms so if connected to the end of a single speaker line the lengths listed above must be halved. If it is desired to run the speaker line under a carpet, TV twin lead may be used for short distances.

PERFORMANCE IMPROVEMENT WITH BUILDING BLOCK KITS

While the SP8C, SP12C and SP15A will provide quite adequate sound reproduction under most circumstances an improvement in performance can easily be realized by adding a tweeter and mid-frequency speaker.

The tweeter will provide the most dramatic improvement and should be added first through the use of a BB1 High-Frequency Building Block Kit. The BB1 includes a T35 horn tweeter, X36 Crossover Network, Level Control, wiring harness and mounting hardware. In addition to extending the high-frequency response beyond the limits of normal audibility the BB1 provides more precise definition of high-frequency wave forms and improved high-frequency dispersion in the listening area. The improved dispersion makes it possible for the listener to move considerably off the central axis while experiencing very little change in sound quality.

The BB4A Mid-Frequency Building Block Kit, consisting of an 1823M Driver, 8HD Diffraction Horn, X8 Crossover Network, and a Level Control with wiring harness provides additional improvement in performance after installation of the BB1. The BB4A further reduces the frequency range which must be reproduced by the cone speaker, reducing harmonic and intermodulation distortion in the total system. The BB4A's diffraction horn improves dispersion in the listening area in addition to increasing efficiency. The improved mid-frequency performance provided by the BB4A is especially important because instrument and voice harmonics which determine the character of the sound are found in this frequency range.

SPECIAL NOTE ON LOW-FREQUENCY PERFORMANCE

The recommended enclosures and associated performance specifications displayed earlier were determined in accordance with the definitive analysis of A. N. Thiele, R. H. Small, and others. The performance of speakers in sealed enclosures (including acoustic suspension types) has been well understood for some time. In contrast, vented systems have been designed using not much more than cut-and-try methods with little real engineering know-how. However, the above mentioned analysis has changed this picture completely.

Thiele showed the similarity between a speaker in an enclosure and an electrical high-pass filter circuit. Application of well known filter analysis techniques led to quite accurate performance calculations for any speaker mounted in any vented or sealed cabinet. Moreover, it was shown that a properly executed speaker/vented-enclosure combination held clear-cut advantages over a sealed system in the areas of efficiency, box size, low-frequency limit, and distortion. These results make the choices of box size, low-frequency limit, efficiency, power-handling capacity, and maximum acoustic power output relatively easy to make. In fact, Thiele even presented in tabular form quite a number of possible vented box choices having optimum performance characteristics (see A. N. Thiele, "Loudspeakers in Vented Boxes: Part I"

J. Audio Eng. Soc., Vol. 19, May 1971, p. 388).

By applying the work of Thiele and Small, Electro-Voice engineers developed a computer program which easily, quickly, and accurately predicts the performance of any speaker-box system in the frequency range where the diaphragm is acting as a simple piston. The upper limit for this operation is - usually the frequency at which the diameter of the diaphragm becomes a large fraction of a wavelength.

The Thiele-Small Driver Parameters shown in the Specifications section include the speaker characteristics required by the computer program to develop the small and large signal performance of a given speaker and enclosure combination.

For more information on this subject, ask for Bulletin 10B. It includes additional vented enclosure recommendations for Electro-Voice component speakers and a detailed bibliography of the work of Thiele, Small, and others. Also, where the Thiele-Small Driver Parameters are known, Bulletin 10B shows how to choose the size and tuning of a vented enclosure and how to determine the low-frequency response of vented and sealed speaker systems using scientific pocket calculators.

WARRANTY (Limited) —

Electro-Voice High Fidelity Speakers and Accessories are guaranteed for five years from date of original purchase against malfunction due to defects in workmanship and materials. If such malfunction occurs, unit will be repaired or replaced (at our option) without charge for materials or labor if delivered prepaid to the proper Electro-Voice service facility. Unit will be returned prepaid. Warranty does not cover finish or appearance items or malfunction due to abuse or operation at other than specified conditions. Repair by other than Electro-Voice or its authorized service agencies will void this warranty.

For correct shipping address, instructions on return of Electro-Voice products for repair, and locations of authorized service agencies, please write: Service Department, Electro-Voice, Inc., 600 Cecil Street, Buchanan, Michigan 49107 (Phone: 616/695-6831).

Electro-Voice also maintains complete facilities for non-warranty service of E-V products.

Specifications subject to change without notice.

© beim Her
Archiv Mi
HiFi