

# Electro-Voice®

ELECTRO-VOICE, INC.  
BUCHANAN, MICHIGAN

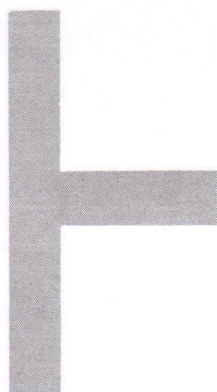

## Specifications and Instructions

### Models SP12 and SP12B

### Radax Coaxial Loudspeakers

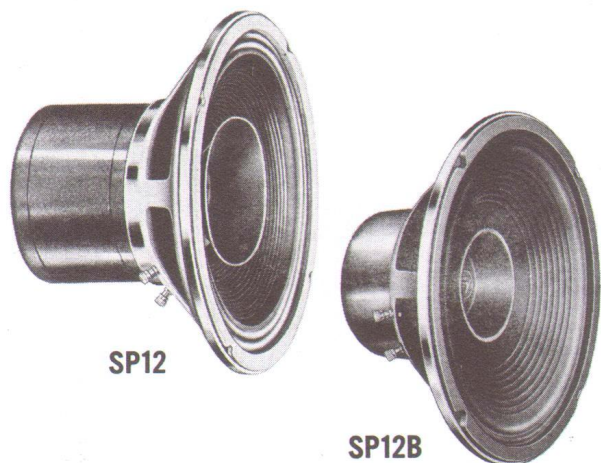

Incorporating all the design advantages of the famous E-V Radax coaxial principle, the E-V Models SP12 and SP12B full-range coaxial reproducers include the latest developments in the electro-acoustic art. Bass response is extended affording, for the first time, pleasing musical balance without the masking effects previously experienced from increased high-frequency reproduction. Tailored to optimum listening requirements, these new developments insure smooth, even coverage of the entire listening area.

**FEATURES** — Exclusive, E-V engineered features include true coaxial mounting of both reproducing elements insuring smooth room coverage; augmented balanced bass response in conjunction with smooth extended high-frequency reproduction. The carefully tailored midrange characteristic provides realism and "presence" at usual sound levels, offsetting ear insensitivity at low volume. The exclusive Radax design features a true acoustical crossover in which the mass of the bass cone and its voice-coil coupling compliance is so proportioned as to decouple the woofer above crossover. The Radax unit is free from phasing dips and displays less than 1/4% harmonic distortion above crossover. The edgewise wound aluminum voice coil design affords 18% more efficiency and consequent damping of transient distortion. An unusually heavy magnet structure is used. The Models SP12 and SP12B may be used as low-frequency drivers in expanded separate 2 and 3-way systems. In this application, the operation of these units is comparable to the E-V Models 12W and 12BW LF drivers. Compatible components for use with these drivers are shown on the "Building-Block Method" Compatibility Chart.

© bein...  
Archiv Mich...  
ELECTRO-VOICE

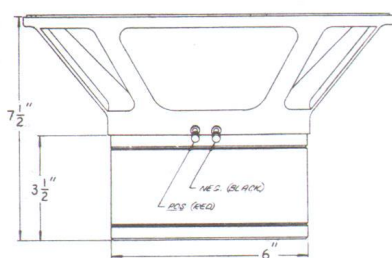

SP12

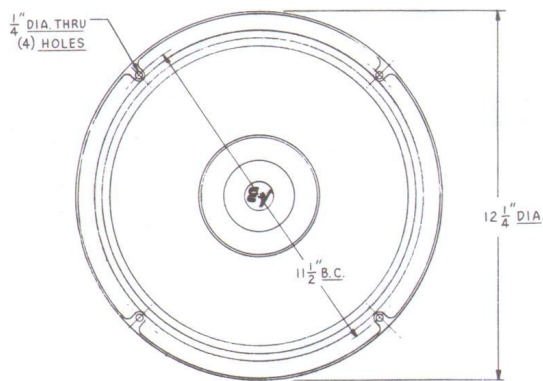

SP12B

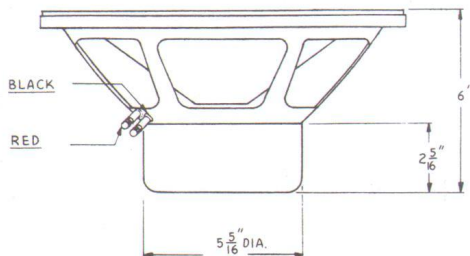

Fig. 1 — Dimensions

## SPECIFICATIONS

	SP12	SP12B
Frequency Response:	30 to 13,000 cps	30 to 13,000 cps
RETMA Sensitivity Rating:	48 db	46.5 db
Free-Space Cone Resonance:	35-45 cps	40-50 cps
Power Handling Capacity:		
Program material:	25 watts	20 watts
Peak:	50 watts	40 watts
Critical Damping Factor:		
In Aristocrat enclosure:	2.0	4.0
In an infinite baffle:	1.0	2.5
Impedance:	16 ohms	16 ohms
Mechanical Crossover:	3000 cps	3500 cps
Voice Coil Diameter:	2 1/2 inches	2 inches
Magnet Weight:	3 lbs	1 lb
Size:	12 1/4 in. dia. x 7 3/4 in. overall depth	12 1/4 in. dia. x 6 in. overall depth
Mounting:	Four 1/4-in. holes equally spaced on 1 1/2-in. circle	
Baffle Opening:	11 inches	11 inches
Net Weight:	19 lb	8 3/4 lb
Shipping Weight:	25 lb	12 lb

Specifications and Instructions

ELECTRO-VOICE Models SP12 and SP12B

## INSTALLATION

Optimum bass response with the SP12 and SP12B units is obtained in the E-V Aristocrat direct-radiator Klipsch-licensed corner horn. Where a baffle is available of the "infinite" type, such as a closet, or a wall with large volumetric capacity available behind the cone, excellent results will be obtained in the accomplishment of the bass range. The ideal volume is 15 cubic feet or more, for with this volume the low free-space resonance of the bass cone becomes the controlling factor in achieving the first octaves. This response will be flat to 35-45 cps.

Where restricted space of only 4 to 8 cubic feet is available for housing the speaker, bass response will suffer and the low range will be compressed by about 1 octave. This deficiency may be offset somewhat by reinforcing the bass through porting the enclosure. Start with an opening of about 130 square inches and gradually decrease this area until most pleasing response is obtained. More accurate design data on this form of enclosure is available from the Reproducing Components Division of Electro-Voice, and in the many articles on enclosure design now published.

Reflections on the interior cavity will cause ragged response, indicated by undue reinforcement at certain frequencies and cancellation at others, unless sound absorbent material is used on at least three of the opposing interior sides. The material may be "Kimsul" 2 inches thick or equivalent. "Kimsul" is available from any building supply house as a product of the Kimberly-Clark Manufacturing Company. Glass wool or glass block is good, but must be covered with cheese cloth to confine the fibers. Blankets, jute, and rug pads are satisfactory substitutes.

**MOUNTING THE SPEAKER** — Cut a circular hole 11 inches in diameter. Four 1/4-inch mounting holes are provided on the outer periphery of the speaker frame. Use four #12 x 1 1/2-inch long wood screws, or preferably drill four 1/4-inch holes on a 1 1/2-inch circle spaced 90 degrees apart (See Fig. 1 for hole arrangement), and employ four 3/16-inch carriage bolts 2 inches long with hex nuts and washers. Secure the speaker to the front baffle and tighten the retaining screws just enough to compress the speaker gasket. Do not tighten too much or the frame may be sprung out of line, resulting in damage to the speaker unit.

## OPERATION

**CONNECTIONS** — Use No. 22 fixture wire or larger to connect the two terminals on the loudspeaker to the "16-ohm" and "Common" output terminals on your amplifier. The 16-ohm impedance of the SP12 and SP12B is a standard RETMA rating. A mismatch by as much as 40% may be made without affecting the reproduction or efficiency of the unit. If only an 8-ohm tap is available on the amplifier, a loss of efficiency will be just noticeable. Connected to a 4-ohm terminal, a loss of overall efficiency will be observed.

**AMPLIFIER DAMPING CONTROL SETTING** — If your amplifier has a variable damping control, as do all E-V units, set this control in accordance with the critical damping factor denoted under "Specifications".

## THE "BUILDING-BLOCK METHOD"

All Electro-Voice enclosures incorporate facilities for later addition of high-frequency and midrange reproducers and their associated crossover networks. The suggested optimum enclosure for the SP12 and SP12B, the Aristocrat direct-radiator corner horn, has these features preinstalled. Further details are covered in Bulletin SA10, the "Building-Block Select-O-Guide," and the Aristocrat instruction brochure. Installation data and instructions are packed with the individual units.

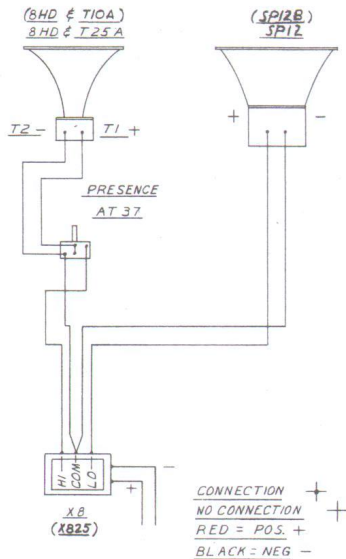

Fig. 2 — Schematic Wiring Diagram  
Separate 2-way System

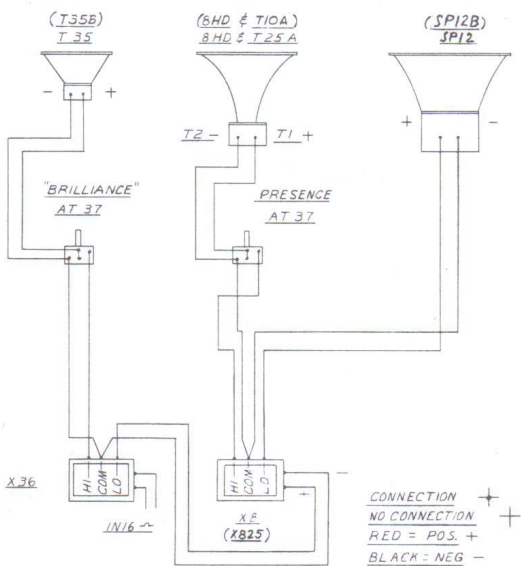
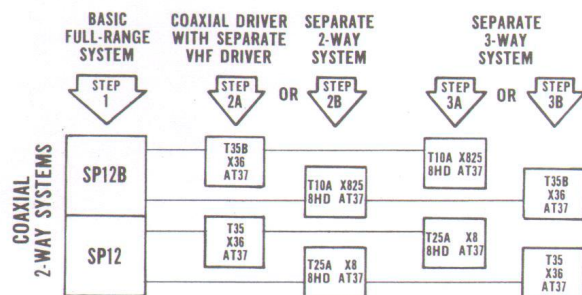

Fig. 3 — Schematic Wiring Diagram  
Separate 3-way System



E-V "Building-Block Method" Compatibility Chart