

Electro-Voice®
a gulton company

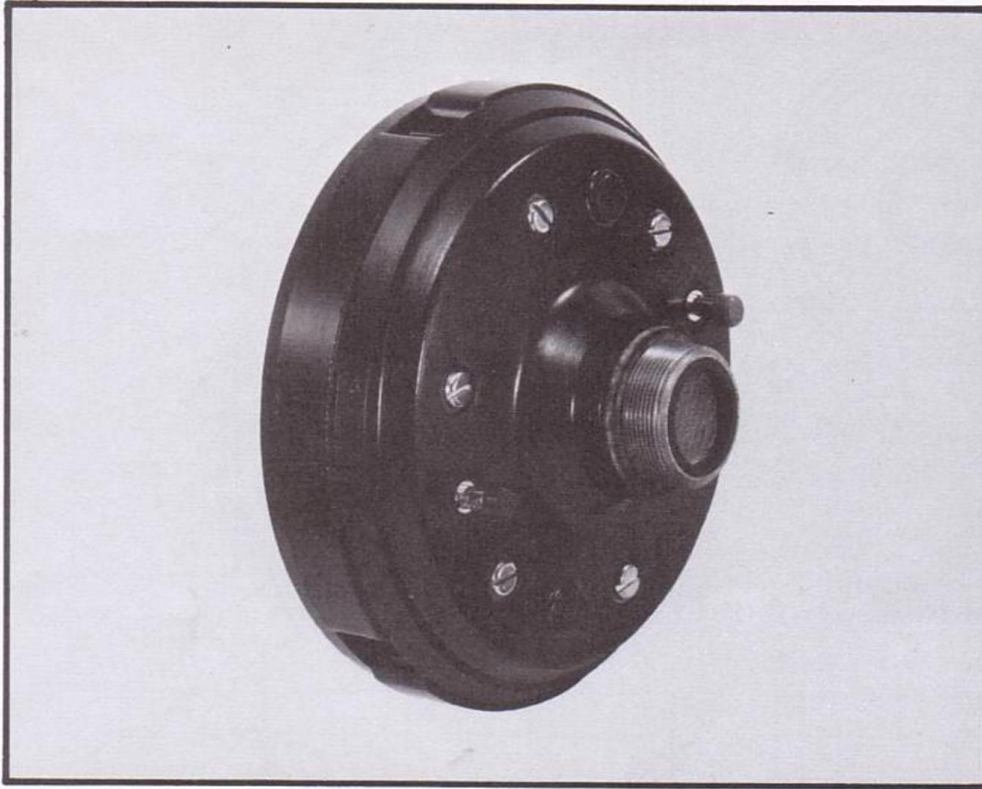

Model DH1506 High Performance Driver

GENERAL SPECIFICATIONS

Power Frequency Response:
500-20,000 Hz (essentially flat
500-3000 Hz, with controlled rolloff
beyond; essentially flat to 20,000 Hz
with appropriate equalization)

Nominal Impedance:
8 ohms

Minimum Impedance:
6.3 ohms (on HR series horns, above
500 Hz)

Nominal DC Resistance:
4.9 ohms

Nominal Efficiency:
25% (band-limited pink noise input,
500-2500 Hz, assuming 8 ohm driver
impedance)

**Crossover Frequencies,
Recommended:**
800 Hz
Minimum:
500 Hz

**Maximum Long-Term Acoustic Power
Output:**
5 watts (see Power Input Limitations
and Driver Protection section)

Long-Term Average Power Capacity:
30 watts (thermal limit)

Voice Coil Diameter:
50 mm (2")

Voice Coil Construction:
Copper-clad aluminum wire on
polyimide form

Diaphragm Construction:
Aluminum dome with polyimide
surround; dome integral with
aluminum coil form

Sound Pressure Level:
104 dB SPL, 1 watt at 10 ft. (ref.
driver) with HR6040

Magnet Material:
Ceramic 5 (barium ferrite)

Horn Throat Diameter:
Usable with 7/8" or 1" diameter
horn throats

Horn Mounting Method:
Screw on, 1-3/8" x 1/8" thread, 5/8"
long

Electrical Connections:
Push terminals; each accommodates
one No. 12 wire

Size:
155 mm (6.125") overall diameter,
99 mm (3.875") overall depth

DESCRIPTION

The Electro-Voice Model DH1506 is a high-performance, high-frequency driver capable of high acoustic power output over a wide frequency range. This performance results from a combination of high conversion efficiency and high power handling capacity attained through design which includes:

1. A drawn aluminum diaphragm with high stiffness to weight ratio for response that extends to 20,000 Hz.
2. A polyimide diaphragm surround for large excursions without the fracture often encountered in drivers with metal surrounds.
3. A very large efficient magnet structure for high flux density.
4. A glass-filled Lexan™ phasing plug of non-conventional design, capable of in-phase transfer of diaphragm

energy. This design helps keep the magnetic gap clear of foreign particles, a serious problem for many conventional high-performance drivers.

TYPICAL USES OF DH1506

The DH1506's combination of ruggedness, high efficiency, and wide-range response makes it more than usually useful for a variety of demanding applications. With excellent response in the octave above 10,000 Hz, the DH1506 on well designed horns may be used as a truly wide-range driver in systems designed for sound reinforcement, stage and studio monitoring, and discos. The DH1506 may also be used as a midrange driver in high-performance multi-way systems.

SUITABLE HORNS AND MOUNTING

The DH1506 has been designed for use with horns having a 1-3/8"-18 mounting thread such as the E-V SM120A and the E-V 8HD. The DH1506 may also be used with the E-V HR series horns by using the ADH-1 adapter. See Figure 2.

Horns used with the DH1506 should have a minimum cutoff frequency equal to or lower than the frequency at which electrical crossover occurs.

DRIVER FREQUENCY RESPONSE

Figure 3 shows sine-wave frequency response and impedance vs. frequency for a typical DH1506 when connected to a pure resistive load. The resistive

*© beim Hersteller
Archiv Michael-Otto*

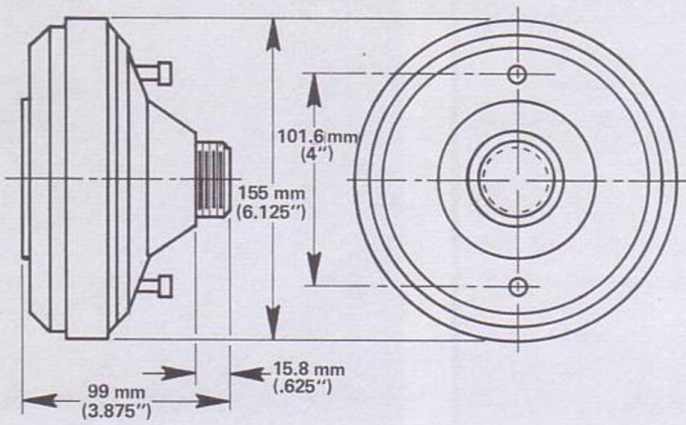

FIGURE 1 – Dimensions

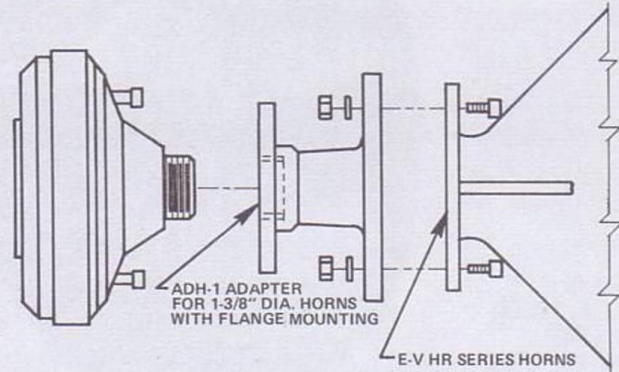
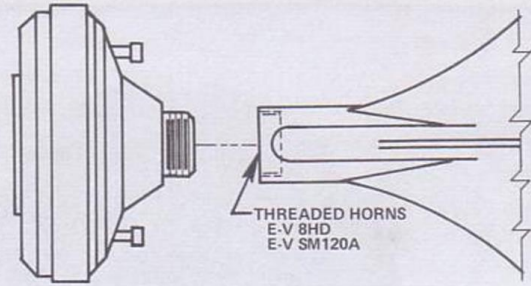
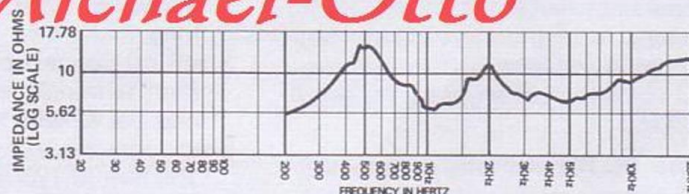
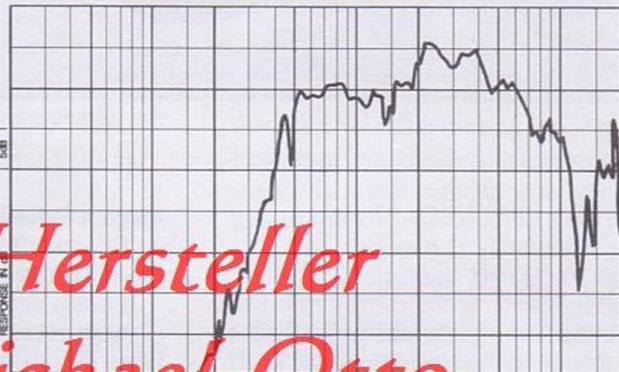
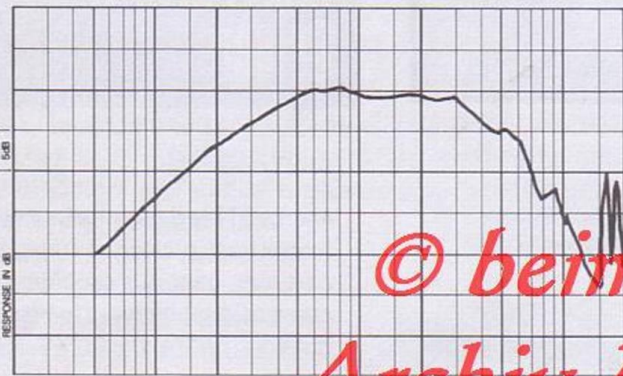
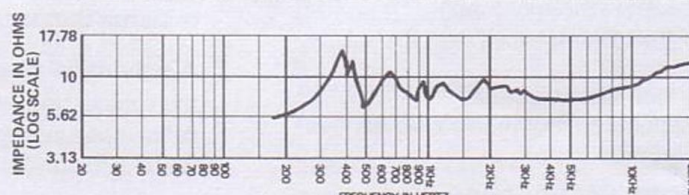
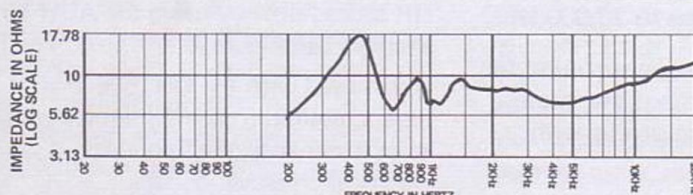
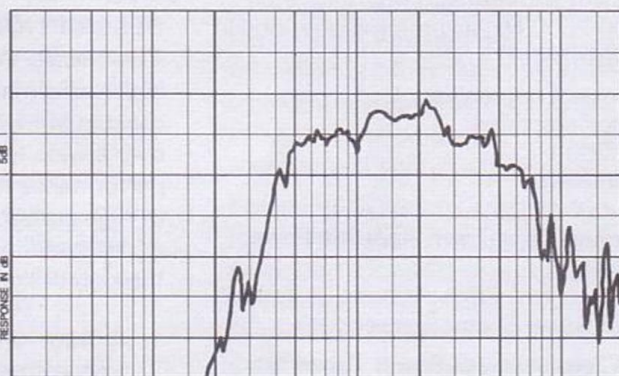
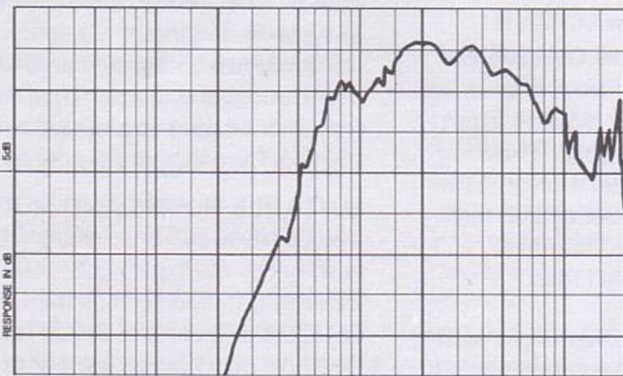

FIGURE 2
Horn Mounting for DH1506



DH1506 FREQUENCY RESPONSE & IMPEDANCE INTO RESISTIVE LOAD

DH1506 WITH SM120A HORN



DH1506 WITH E-V 8HD HORN

DH1506 ON HR9040 WITH ADH-1 ADAPTER

FIGURE 3 – Frequency Response and Impedance Curve of DH1506 with Resistive Load and Various Horns

*© beim Hersteller
Archiv Michael-Otto*

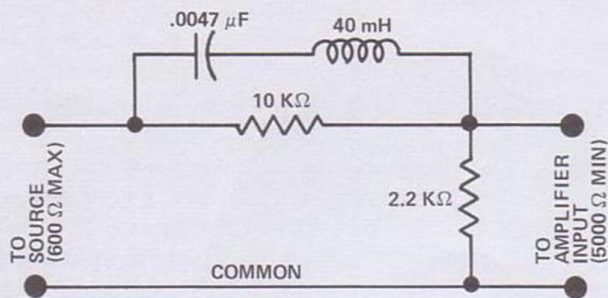

FIGURE 4 – Schematic for Recommended Equalization

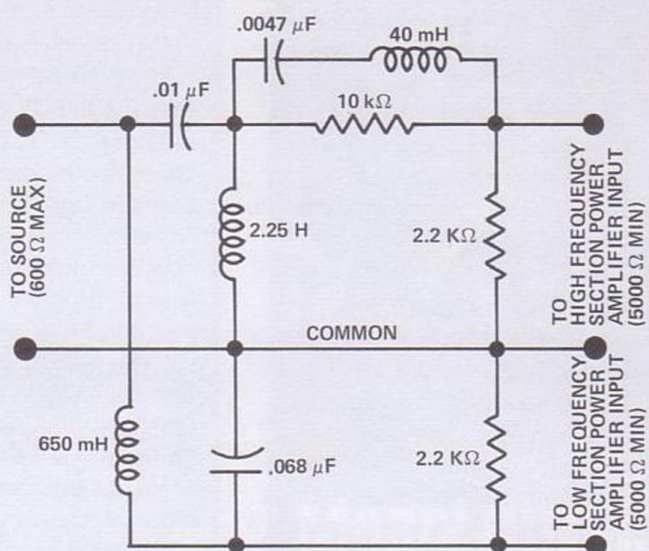
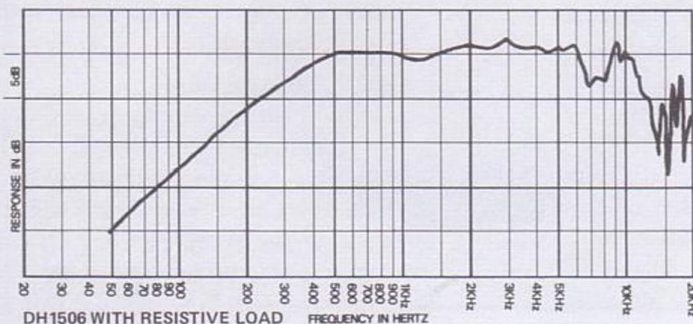

FIGURE 6
Schematic for Low Level Crossover and Equalization Network to Feed High Impedance Power Amplifier Inputs

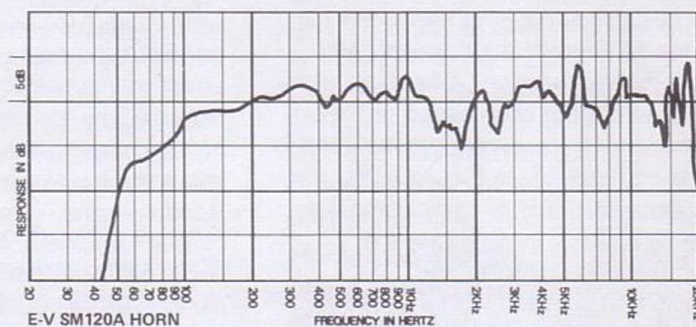
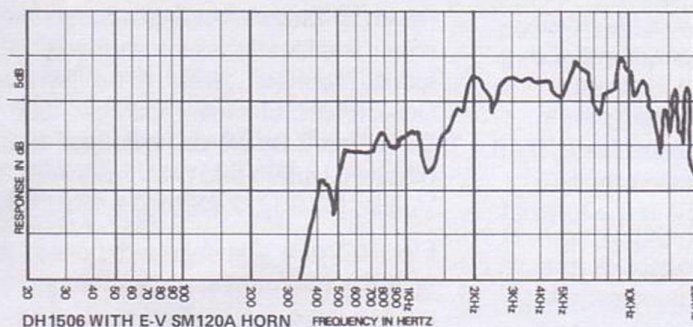
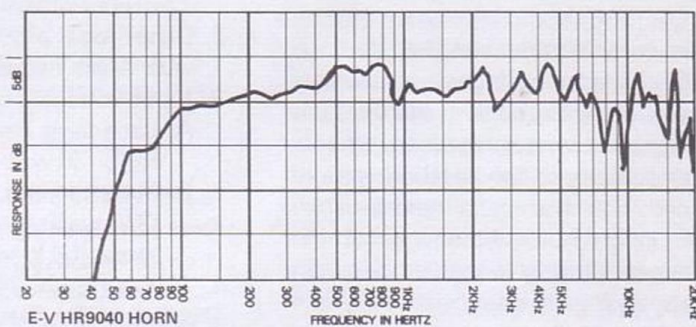
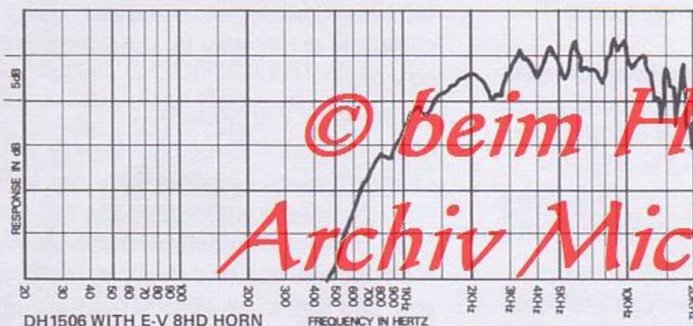

FIGURE 5

Frequency Response of DH1506 with Resistive Load and Various Horns with Recommended Equalization

FIGURE 7

Frequency Response of the DH1506 with Various Horns Combined with a TL606 Bass Box through the Recommended Crossover and Equalization Network

load, provided by an appropriately terminated plane-wave tube, reveals the driver's total output vs. frequency, unmodified by horn reactive components and dispersion changes.

Since an actual horn modifies driver performance, the on-axis anechoic frequency response of a typical DH1506 with several horns is also shown in Figure 3.

RECOMMENDED EQUALIZATION

Some degree of electrical equalization is normally required with any wide-range driver, the amount dependent upon specific use. Elaborate one-third octave filters are typically used for equalization, but the DH1506 has been purposely designed for a response that can be made essentially flat to 20,000 Hz by using a simple, smooth filter. This passive, low-level circuit is shown in Figure 4. The network may be used for bi-amped applications and contains a maximum of approximately 15 dB high-frequency boost. The frequency response of an equalized DH1506 with a resistive load, an E-V SM120A horn, and E-V 8HD horn and an E-V HR9040 horn is shown in Figure 5. The exceptionally uniform horizontal dispersion of the SM120A, and the exceptionally uniform dispersion in both planes of the HR9040, provide on-axis frequency responses which are unusually close to the response with a resistive load.

CROSSOVER FREQUENCY

The DH1506 should be crossed over at a minimum of 500 Hz with 800 Hz recommended. Any higher crossover frequency is acceptable. If 500 Hz is used as the crossover frequency, the power capacity of the DH1506 is reduced. The crossover should have a minimum attenuation below cutoff of 12 dB per octave.

COMPLETE SYSTEMS

The DH1506 with equalization previously shown can be expanded to include an appropriate crossover and bass frequency section. A possible crossover network has been added to the recommended equalization circuit and is shown in Figure 6. In Figure 7 the frequency response of three complete systems is given. In each case the recommended crossover and equalization are used with a DH1506 and a TL606 bass system.

The horns selected are the E-V SM120A, the E-V HR6040 and the E-V HR9040. In each case the DH1506 driver and the woofer are aligned in the

same plane and electrically out of phase. Other driver positions would provide some response deviations near the crossover which are essentially inaudible.

POWER INPUT LIMITATIONS AND DRIVER PROTECTION

Driver failure may normally be expected to occur from exceeding thermal limits or overstressing flexing parts (due to excessive diaphragm displacement). Normal program material has considerable amplitude variations and these variations must be considered to ensure that peak values stay within reasonable limits. Although actual driver limitations are dependent on a number of varied and complex program material, crossover, and load (horn) characteristics, the following guidelines may be observed:

1. Displacement limitations become less of a problem for higher crossover frequencies and for lower horn cutoff frequencies.
2. Driver lifetime can be increased by lower average input levels and higher crossover (and lower horn cutoff) frequencies.
3. Excessive amplifier power relative to that absolutely required increases the possibility of failure or damage during excessive input levels.

With these notes in mind, the following tests are used by Electro-Voice for quality assurance.

1. **Test spectrum:** pink noise, band limited at 800 Hz and 10 kHz, using 12-dB-per-octave slopes.
2. **Driver load:** any E-V HR series horn with ADH-1 adapter.
3. **Input voltage:**
 - A. **Long-term average:** 15.5 volts true RMS (30 watts into 8 ohms)
 - B. **Instantaneous peak:** ± 55 volts (378 watts into 8 ohms; 11 dB above the long-term average)
4. **Test duration:** 24 hours.

The key to the above procedure is the input signal. Historically, power tests and ratings have been poor representatives of the rigors of actual use. To effectively simulate real program material, the test signal should have instantaneous peak values at least 10 dB above the long-term average level. Random noise — usually in the form of "white" noise (constant energy per cycle) or "pink" noise (constant energy per octave) — meets these criteria in a reproducible, standard way. A random noise input has a peak-to-average ratio far more realistic than sine wave signals and avoids the ambiguity of the various "program material" ratings.

In many systems where DC-coupled amplifiers are used in a bi-amped configuration, it is advisable to provide DC blocking for driver protection in case of amplifier failure. This can be accomplished by use of a series blocking capacitor between amplifier output and driver. In this case, a nonpolarized capacitor with a value between 50 and 100 microfarads is recommended. Voltage ratings should equal or exceed amplifier output capability. Such capacitors can be readily purchased as AC motor starting capacitors. Alternately, a line transformer as used in sound reinforcement systems may provide such protection.

FIELD REPLACEMENT

In case of voice-coil or diaphragm failure, the diaphragm plate sub-assembly can be field replaced by the removal of six cover screws and two terminal screws. A replacement kit with instructions may be ordered under Electro-Voice Part No. 88786-XX from the Electro-Voice Service Department in Buchanan, Michigan. If desired, the complete driver may be returned for service.

WARRANTY (Limited) —

Electro-Voice Professional Sound Reinforcement Loudspeakers and Accessories are guaranteed for five years from date of original purchase against malfunction due to defects in workmanship and materials. If such malfunction occurs, unit will be repaired or replaced (at our option) without charge for materials or labor if delivered prepaid to the proper Electro-Voice service facility. Unit will be returned prepaid. Warranty does not cover finish or appearance items or malfunction due to abuse or operation at other than specified conditions. Repair by other than Electro-Voice or its authorized service agencies will void this guarantee.

For shipping address and instructions on return of Electro-Voice products for repair and locations of authorized service agencies, please write: Service Department, Electro-Voice, Inc., 600 Cecil Street, Buchanan, Michigan 49107 (Phone 616/695-6831) or 7473 Ave. 304, Visalia, CA 93277 (209/625-1330,-1).

Electro-Voice also maintains complete facilities for non-warranty service.

Service and repair address for this product: Electro-Voice, Inc., 600 Cecil St., Buchanan, Michigan 49107.

Specifications subject to change without notice.

Part No. 53226-928

a **Gulton** COMPANY **ELECTRO-VOICE, Inc., 600 CECIL ST., BUCHANAN, MICH. 49107**

MANUFACTURING PLANTS AT ■ BUCHANAN, MICH. ■ NEWPORT, TENN. ■ SEVIERVILLE, TENN. ■ GANANOQUE, ONT. ■ LITHO IN U.S.A.

© beim Hersteller
Archiv Michael-Otto

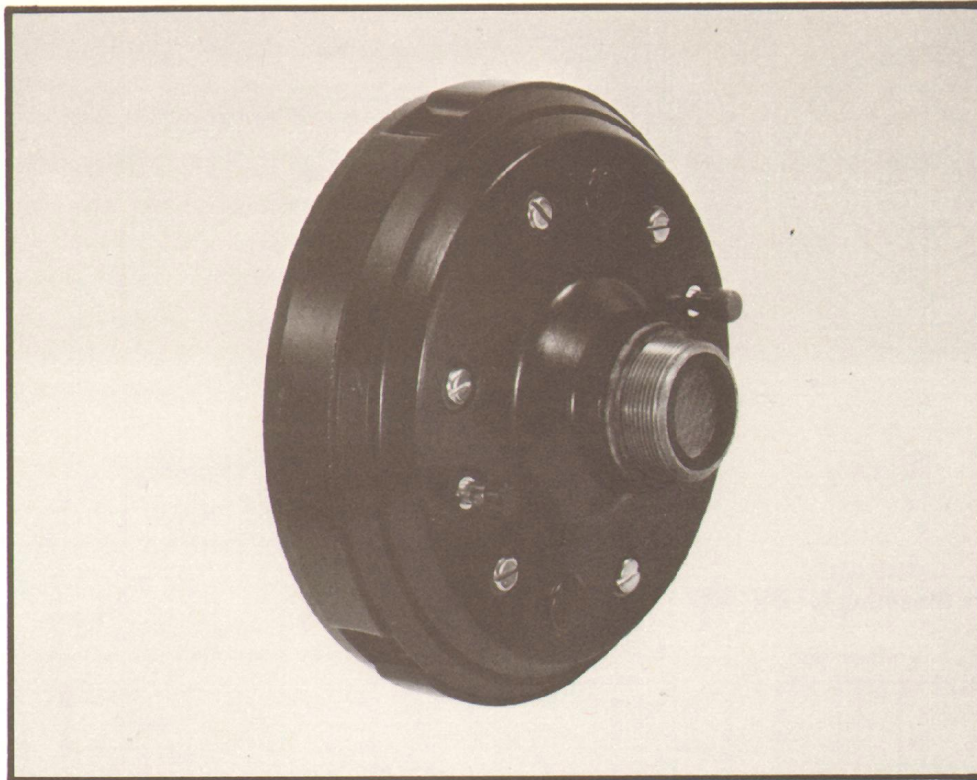

Model DH1506 High Performance Driver

GENERAL SPECIFICATIONS

Power Frequency Response
500-20,000 Hz (essentially flat
500-3000 Hz, with controlled rolloff
beyond; essentially flat to 20,000 Hz
with appropriate equalization)

Nominal Impedance:
8 ohms

Minimum Impedance:
6.3 ohms (on HR series horns, above
500 Hz)

Nominal DC Resistance:
4.9 ohms

Nominal Efficiency:
25% (band-limited pink noise input,
500-2500 Hz, assuming 8 ohm driver
impedance)

**Crossover Frequencies,
Recommended:**
800 Hz
Minimum:
500 Hz

**Maximum Long-Term Acoustic Power
Output:**
5 watts (see Power Input Limitations
and Driver Protection section)

Long-Term Average Power Capacity:
30 watts (thermal limit)

Voice Coil Diameter:
50 mm (2")

Voice Coil Construction:
Copper-clad aluminum wire on
polyimide form

Diaphragm Construction:
Aluminum dome with polyimide
surround; dome integral with
aluminum coil form

Sound Pressure Level:
104 dB SPL, 1 watt at 10 ft. (ref.
driver) with HR6040

Magnet Material:

Ceramic 5 (barium ferrite)

Horn Throat Diameter:

Usable with 7/8" or 1" diameter
horn throats

Horn Mounting Method:

Screw-on, 1-3/8" -18 thread, 5/8"
long

Electrical Connections:

Push terminals; each accommodates
one No. 12 wire

Size:

155 mm (6.125") overall diameter,
99 mm (3.875") overall depth

DESCRIPTION

The Electro-Voice Model DH1506 is a high-performance, high-frequency driver capable of high acoustic power output over a wide frequency range. This performance results from a combination of high conversion efficiency and high power handling capacity attained through design which includes:

1. A drawn aluminum diaphragm with high stiffness to weight ratio for response that extends to 20,000 Hz.
2. A polyimide diaphragm surround for large excursions without the fracture often encountered in drivers with metal surrounds.
3. A very large efficient magnet structure for high flux density.
4. A glass-filled Lexan™ phasing plug of non-conventional design, capable of in-phase transfer of diaphragm

energy. This design helps keep the magnetic gap clear of foreign particles, a serious problem for many conventional high-performance drivers.

TYPICAL USES OF DH1506

The DH1506's combination of ruggedness, high efficiency, and wide-range response makes it more than usually useful for a variety of demanding applications. With excellent response in the octave above 10,000 Hz, the DH1506 on well designed horns may be used as a truly wide-range driver in systems designed for sound reinforcement, stage and studio monitoring, and discos. The DH1506 may also be used as a midrange driver in high-performance multi-way systems.

SUITABLE HORNS AND MOUNTING

The DH1506 has been designed for use with horns having a 1-3/8"-18 mounting thread such as the E-V SM120A and the E-V 8HD. The DH1506 may also be used with the E-V HR series horns by using the ADH-1 adapter. See Figure 2.

Horns used with the DH1506 should have a minimum cutoff frequency equal to or lower than the frequency at which electrical crossover occurs.

DRIVER FREQUENCY RESPONSE

Figure 3 shows sine-wave frequency response and impedance vs. frequency for a typical DH1506 when connected to a pure resistive load. The resistive

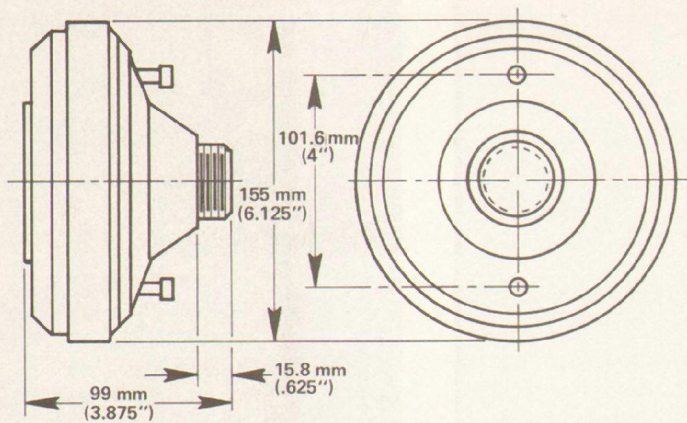

FIGURE 1 - Dimensions

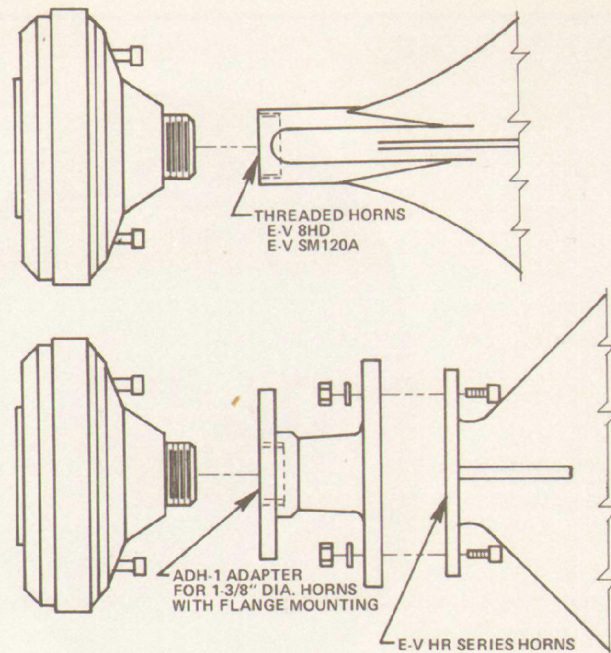

FIGURE 2
Horn Mounting for DH1506

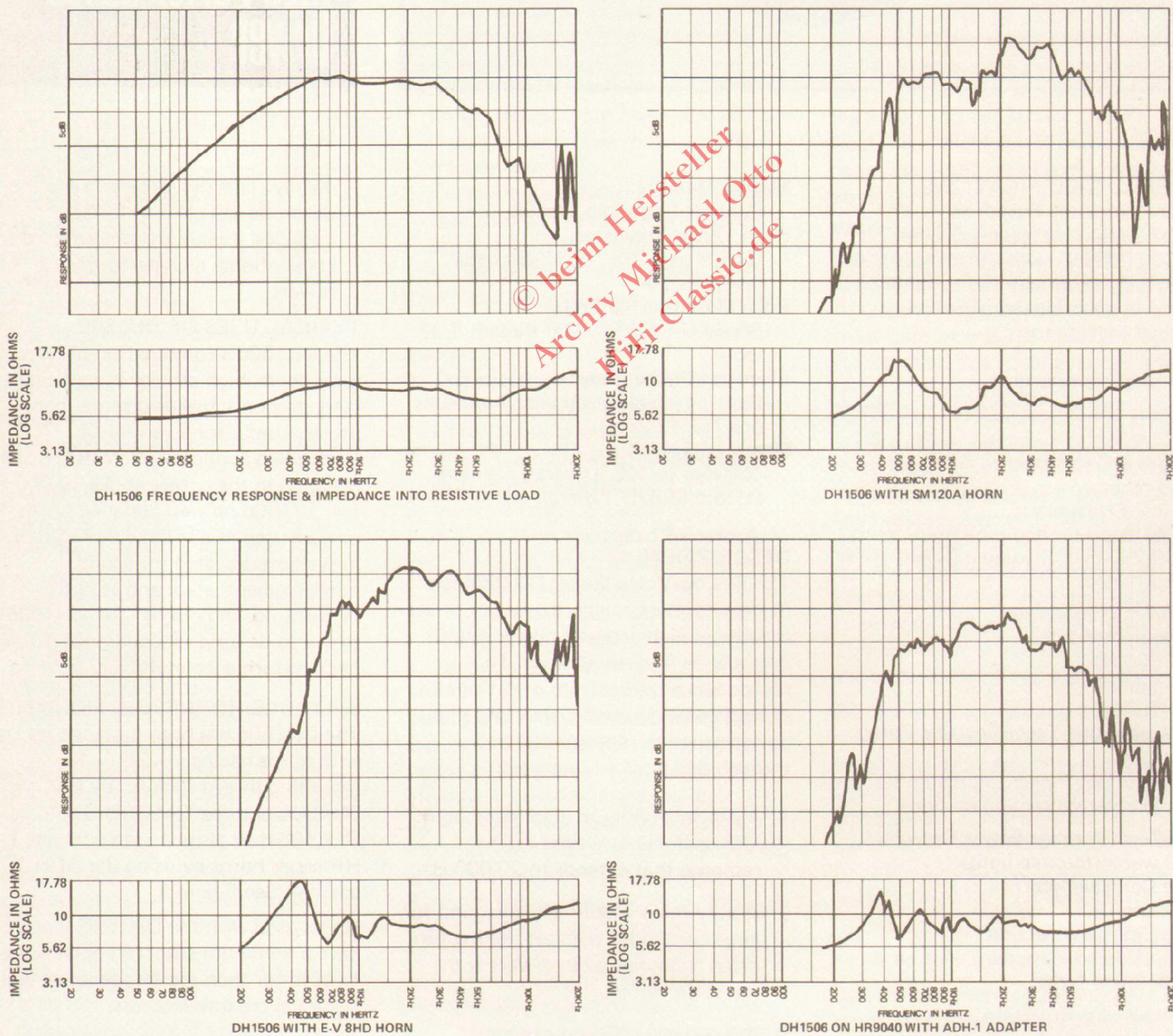

FIGURE 3 - Frequency Response and Impedance Curve of DH1506 with Resistive Load and Various Horns

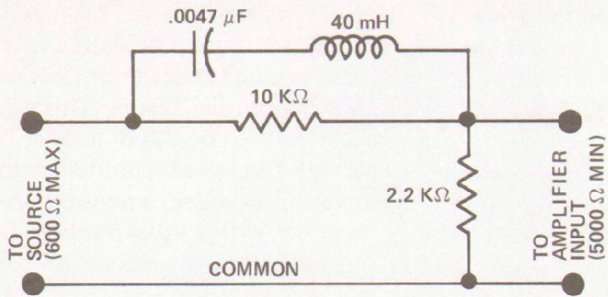

FIGURE 4 – Schematic for Recommended Equalization

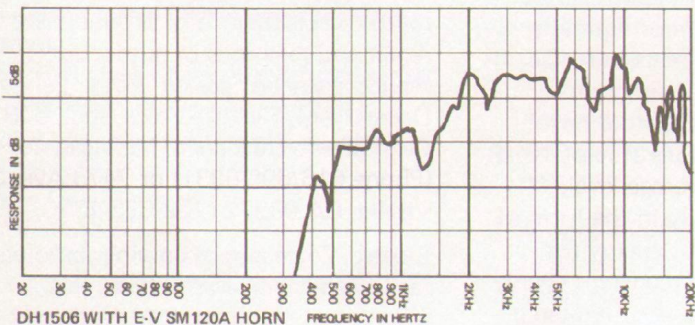
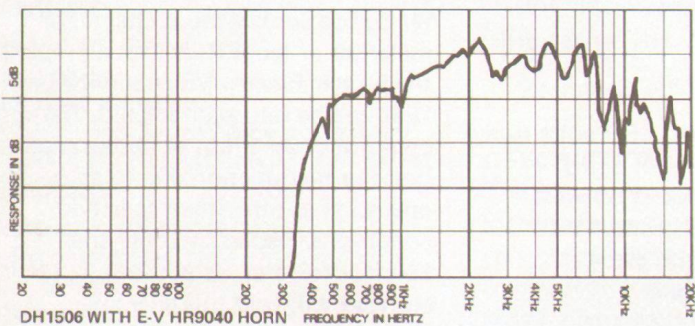
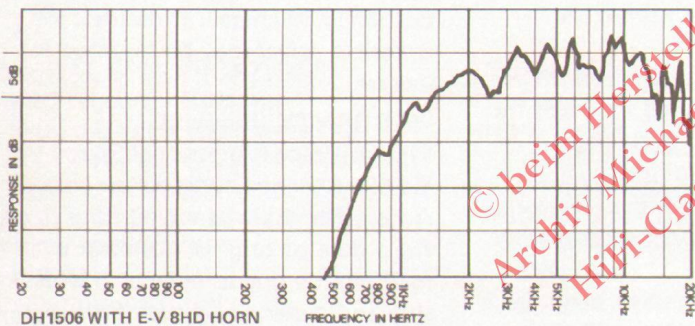

FIGURE 5

Frequency Response of DH1506 with Resistive Load and Various Horns with Recommended Equalization

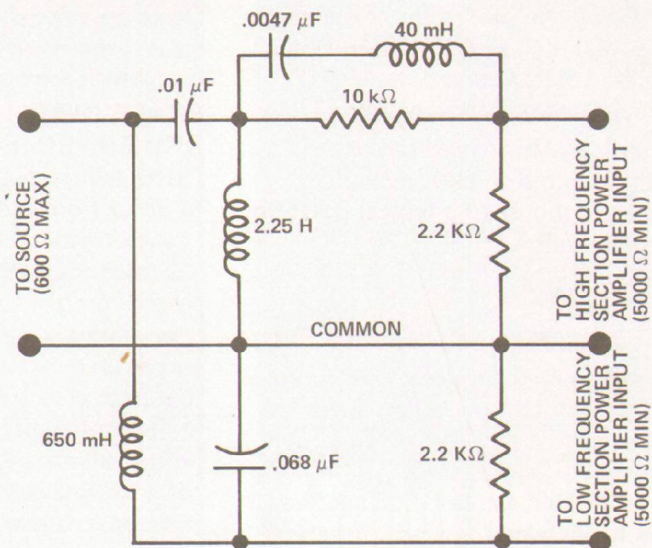

FIGURE 6

Schematic for Low Level Crossover and Equalization Network to Feed High Impedance Power Amplifier Inputs

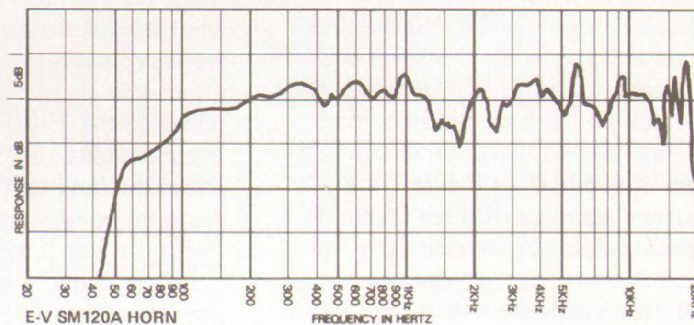
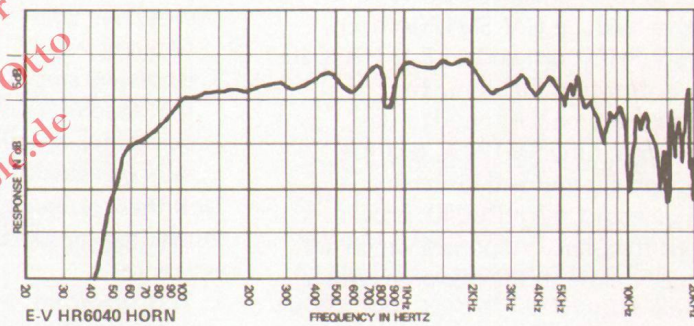

FIGURE 7

Frequency Response of the DH1506 with Various Horns Combined with a TL606 Bass Box through the Recommended Crossover and Equalization Network

load, provided by an appropriately terminated plane-wave tube, reveals the driver's total output vs. frequency, unmodified by horn reactive components and dispersion changes.

Since an actual horn modifies driver performance, the on-axis anechoic frequency response of a typical DH1506 with several horns is also shown in Figure 3.

RECOMMENDED EQUALIZATION

Some degree of electrical equalization is normally required with any wide-range driver, the amount dependent upon specific use. Elaborate one-third octave filters are typically used for equalization, but the DH1506 has been purposely designed for a response that can be made essentially flat to 20,000 Hz by using a simple, smooth filter. This passive, low-level circuit is shown in Figure 4. The network may be used for bi-amped applications and contains a maximum of approximately 15 dB high-frequency boost. The frequency response of an equalized DH1506 with a resistive load, an E-V SM120A horn, and E-V 8HD horn and an E-V HR9040 horn is shown in Figure 5. The exceptionally uniform horizontal dispersion of the SM120A, and the exceptionally uniform dispersion in both planes of the HR9040, provide on-axis frequency responses which are unusually close to the response with a resistive load.

CROSSOVER FREQUENCY

The DH1506 should be crossed over at a minimum of 500 Hz with 800 Hz recommended. Any higher crossover frequency is acceptable. If 500 Hz is used as the crossover frequency, the power capacity of the DH1506 is reduced. The crossover should have a minimum attenuation below cutoff of 12 dB per octave.

COMPLETE SYSTEMS

The DH1506 with equalization previously shown can be expanded to include an appropriate crossover and bass frequency section. A possible crossover network has been added to the recommended equalization circuit and is shown in Figure 6. In Figure 7 the frequency response of three complete systems is given. In each case the recommended crossover and equalization are used with a DH1506 and a TL606 bass system.

The horns selected are the E-V SM120A, the E-V HR6040 and the E-V HR9040. In each case the DH1506 driver and the woofer are aligned in the

same plane and electrically out of phase. Other driver positions would provide some response deviations near the crossover which are essentially inaudible.

POWER INPUT LIMITATIONS AND DRIVER PROTECTION

Driver failure may normally be expected to occur from exceeding thermal limits or overstressing flexing parts (due to excessive diaphragm displacement). Normal program material has considerable amplitude variations and these variations must be considered to ensure that peak values stay within reasonable limits. Although actual driver limitations are dependent on a number of varied and complex program material, crossover, and load (horn) characteristics, the following guidelines may be observed:

1. Displacement limitations become less of a problem for higher crossover frequencies and for lower horn cutoff frequencies.
2. Driver lifetime can be increased by lower average input levels and higher crossover (and lower horn cutoff) frequencies.
3. Excessive amplifier power relative to that absolutely required increases the possibility of failure or damage during excessive input levels.

With these notes in mind, the following test is used by Electro-Voice for quality assurance:

1. **Test spectrum:** pink noise, band limited at 800 Hz and 10 kHz, using 12-dB-per-octave slopes.
2. **Driver load:** any E-V HR series horn with ADH-1 adapter.
3. **Input voltage:**
 - A. **Long-term average:** 15.5 volts true RMS (30 watts into 8 ohms)
 - B. **Instantaneous peak:** ± 55 volts (378 watts into 8 ohms; 11 dB above the long-term average)
4. **Test duration:** 24 hours.

The key to the above procedure is the input signal. Historically, power tests and ratings have been poor representatives of the rigors of actual use. To effectively simulate real program material, the test signal should have instantaneous peak values at least 10 dB above the long-term average level. Random noise — usually in the form of "white" noise (constant energy per cycle) or "pink" noise (constant energy per octave) — meets these criteria in a reproducible, standard way. A random noise input has a peak-to-average ratio far more realistic than sine wave signals and avoids the ambiguity of the various "program material" ratings.

In many systems where DC-coupled amplifiers are used in a bi-amped configuration, it is advisable to provide DC blocking for driver protection in case of amplifier failure. This can be accomplished by use of a series blocking capacitor between amplifier output and driver. In this case, a nonpolarized capacitor with a value between 50 and 100 microfarads is recommended. Voltage ratings should equal or exceed amplifier output capability. Such capacitors can be readily purchased as AC motor starting capacitors. Alternately, a line transformer as used in sound reinforcement systems may provide such protection.

FIELD REPLACEMENT

In case of voice-coil or diaphragm failure, the diaphragm plate sub-assembly can be field replaced by the removal of six cover screws and two terminal screws. A replacement kit with instructions may be ordered under Electro-Voice Part No. 88786-XX from the Electro-Voice Service Department in Buchanan, Michigan. If desired, the complete driver may be returned for service.

WARRANTY (Limited) —

Electro-Voice Professional Sound Reinforcement Loudspeakers and Accessories are guaranteed for five years from date of original purchase against malfunction due to defects in workmanship and materials. If such malfunction occurs, unit will be repaired or replaced (at our option) without charge for materials or labor if delivered prepaid to the proper Electro-Voice service facility. Unit will be returned prepaid. Warranty does not cover finish or appearance items or malfunction due to abuse or operation at other than specified conditions. Repair by other than Electro-Voice or its authorized service agencies will void this guarantee.

For shipping address and instructions on return of Electro-Voice products for repair and locations of authorized service agencies, please write: Service Department, Electro-Voice, Inc., 600 Cecil Street, Buchanan, Michigan 49107 (Phone 616/695-6831) or 7473 Ave. 304, Visalia, CA 93277 (209/625-1330,-1).

Electro-Voice also maintains complete facilities for non-warranty service.

Service and repair address for this product: Electro-Voice, Inc., 600 Cecil St., Buchanan, Michigan 49107.

Specifications subject to change without notice.

Part No. 53226-928

a **Gulton** COMPANY **ELECTRO-VOICE, Inc., 600 CECIL ST., BUCHANAN, MICH. 49107**

MANUFACTURING PLANTS AT ■ BUCHANAN, MICH. ■ NEWPORT, TENN. ■ SEVIERVILLE, TENN. ■ GANANOQUE, ONT. ■ LITHO IN U.S.A.