

Fig. 2 — Schematic Wiring Diagram  
Separate 2-way System

Reflections on the interior cavity will cause ragged response, indicated by undue reinforcement at certain frequencies and cancellation at others, unless sound absorbent material is used on at least three of the opposing interior sides. The material may be "Kimsul" 2 inches thick or equivalent. "Kimsul" is available from any building supply house as a product of the Kimberly-Clark Manufacturing Company. Glass wool or glass block is good, but should be covered with cheese cloth to confine the fibers. Blankets, jute, and rug pads are satisfactory substitutes. The rear cavity for the 15WK and 15BWK must be completely sealed and airtight for best bass response. In this application, padding is not needed. The precise size of this cavity is dependent on the design application. For further information see bulletin No. 210 on the construction of the Georgian enclosure.

**MOUNTING THE SPEAKER** — Cut a circular hole 13½ inches in diameter. Four ¼-inch mounting holes are provided on the outer periphery of the speaker frame. Use four #12 x 1½ inch long wood screws, or preferably drill four ¼-inch holes on a 14⅞-inch circle spaced 90 degrees apart (See Fig. 1 for the hole arrangement), and employ four ⅜-inch carriage bolts 2 inches long with hex nuts and washers. Secure the speaker to the front baffle and tighten the retaining screws just enough to compress the speaker gasket. Do not tighten too much or the frame may be sprung out of line, thus damaging the speaker unit.

## OPERATION

**CONNECTIONS** — Use No. 22 fixture wire or larger to connect the two terminals on the low frequency drivers to the "low" and "Common" output terminals on the crossover network. The exact crossover frequency is dependent on the application but it is recommended to be below 1200 cps. The 16-ohm impedance of the driver units is a standard RETMA rating and is indicative of the voice coil impedance at crossover frequency. A mismatch by as much as 40% may be made without affecting the reproduction or efficiency of the unit.

**AMPLIFIER DAMPING CONTROL SETTING** — If your amplifier has a variable damping control, as do all E-V units, set this control in accordance with the critical damping factor listed under specifications.

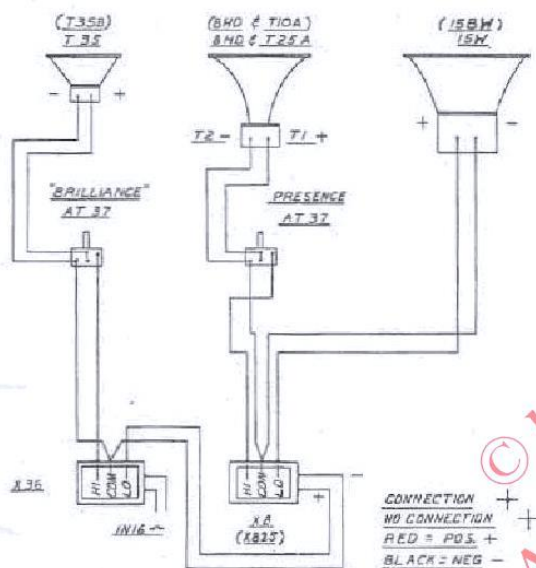

Fig. 3 — Schematic Wiring Diagram  
Separate 3-way System

## THE "BUILDING-BLOCK METHOD"

All Electro-Voice enclosures incorporate facilities for later addition of high-frequency and midrange reproducers and their associated crossover networks. The suggested optimum enclosures for the 15W and 15BW, the Regency and Empire direct radiator corner horns have these features preinstalled. Further details are covered in Bulletin SA10, the "Building-Block Select-O-Guide," and the Regency and Empire instruction brochures. Installation and instructions are packed with the individual drivers.

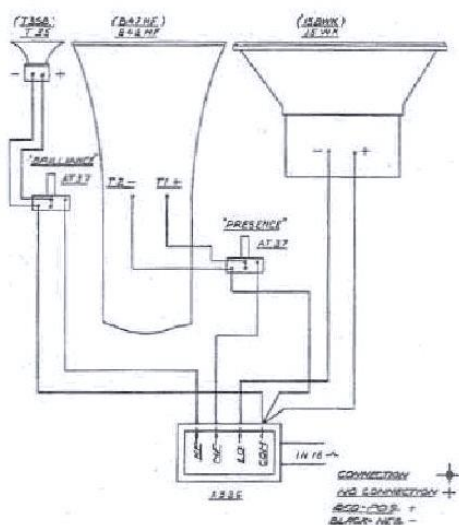
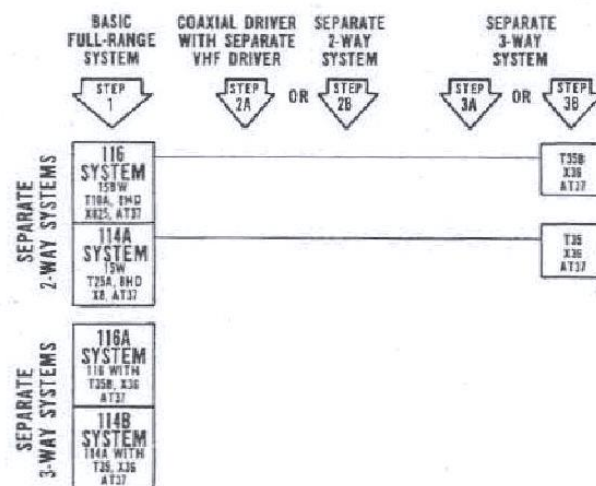

Fig. 4 — Schematic Wiring Diagram  
Indirect Radiator 4-way System



E-V "Building-Block Method" Compatibility Chart

# Electro-Voice

ELECTRO-VOICE, INC.  
BUCHANAN, MICHIGAN

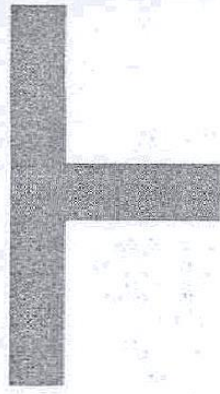

## Specifications and Instructions

### Models 15W, 15BW, 15WK, 15BWK Low-Frequency Drivers

Incorporating all the design advantages of piston-type low-frequency drivers, the E-V 15-inch reproducers include also the latest developments in the electro-acoustic art. Bass response is phenomenal, affording for the first time, pleasing musical balance without the masking effects previously experienced from high cone resonance and inefficient voice coil gap designs. E-V low-frequency drivers have special cone and spider suspensions as well as one-piece, welded magnetic structures of exclusive design. Tailored to optimum listening requirements, these new developments insure smooth even coverage of the entire bass spectrum.

**FEATURES** — Exclusive, E-V engineered features include true concentric centering of the voice coil; augmented balanced bass response in conjunction with the production of a plane wave-front; especially rugged voice-coil cone juncture; edge-wise-wound aluminum voice coil design affording 18% more efficiency and consequent damping of transient distortion; heavy magnet structure with one-piece, all-welded construction.

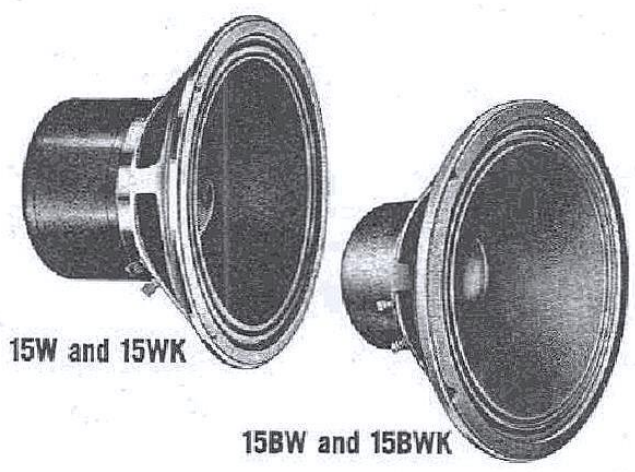

15W and 15WK

15BW and 15BWK

### SPECIFICATIONS

	15W	15BW	15WK	15BWK
Frequency Response:	Essentially flat to 1200 cps. Exact response depends on enclosure.			
RETMA Sensitivity Rating:	50 db	46 db	50 db	47 db
Free-Space Cone Resonance:	25-35 cps	38-48 cps	25-35 cps	38-48 cps
Power Handling Capacity:				
Program Material:	30 watts	20 watts	30 watts	20 watts
Peak:	60 watts	40 watts	60 watts	40 watts
Critical Damping Factor:	1 in Regency or Empire; 0.5 in infinite baffle	2 in Regency or Empire; 1 in infinite baffle	10 in Centurion, Georgian or Klipsch	10 in Centurion or Klipsch
Nominal Impedance:	16 ohms	16 ohms	16 ohms	16 ohms
D. C. Resistance:	11.6 ohms	11.6 ohms	3.2 ohms	3.2 ohms
Voice Coil Diameter:	2½ inches	2 inches	2½ inches	2 inches
Magnet Weight:	5¼ lbs	1 lb	5¼ lbs	1 lb
Size:	15½ in. dia. x 9 in. deep overall	15½ in. diam. x 7½ in. deep overall	15½ in. dia. x 9 in. deep overall	15½ in. dia. x 7½ in. deep overall
Mounting:	Four ¼ in. holes equally spaced on 14½-in. circle			
Baffle Opening:	13½ in.	13½ in.	13½ in.	13½ in.
Net Weight:	37 lb	12 lb	37 lb	12 lb
Shipping Weight:	41 lb	15 lb	41 lb	15 lb
Net Price:	\$78.00	\$39.00	\$78.00	\$39.00

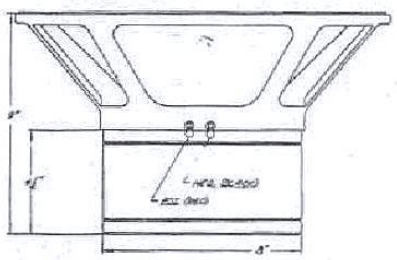

15W and 15WK

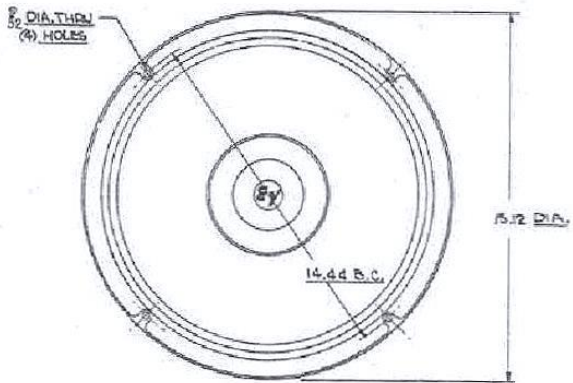

15BW and 15BWK

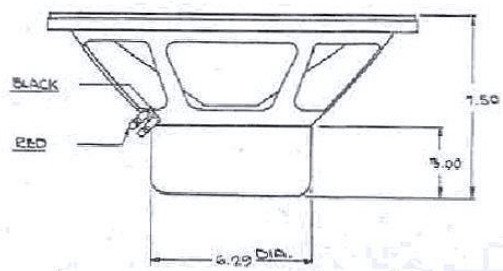

Fig. 1 — Dimensions

### INSTALLATION

Optimum bass response with E-V low-frequency driver units is obtained in the recommended baffles. Where a baffle is available of the "infinite" type, such as a closet, or a wall with large volumetric capacity available behind the cone, excellent results will be obtained in the accomplishment of the bass range. The ideal volume for the 15W and 15BW is 20 cubic feet or more, for with this volume the low free-space resonance of the bass cone becomes the controlling factor in achieving reproduction of the first octaves. The response will be flat to 30-35 cps. The 15WK and 15BWK are recommended for use only in K and W enclosures in which the back air load volume is restricted to approximately 6000 cubic inches. In this application, the front radiation must be horn-loaded.

Where only a restricted space of 4 to 8 cubic feet is available for housing the 15W and 15BW low-frequency drivers, bass response will suffer and the low range will be compressed by about 1 octave. This deficiency may be offset somewhat by reinforcing the bass through porting the enclosure. Start with an opening of about 130 square inches and gradually decrease this area until the most pleasing response is obtained. More accurate design data on this form of enclosure is available from the Reproducing Components Division of Electro-Voice, and in the many articles on enclosure design now published.

Specifications and Instructions  
ELECTRO-VOICE  
MODELS 15W, 15BW, 15WK, 15BWK

© beim Händler  
Archiv Michael O  
www.klassik.de