



FEATURES

- Husky 8-spoke diecast aluminum frame
- Low-mass high-efficiency edgewound voice coil
- Rugged laminated coil form
- Heavy-duty curvilinear cone
- Fatigue-resistant cone suspension
- Vented coil and magnet structure
- Heat radiating back cover

INSTALLATION

The EVM-12L may be front- or rear-mounted, although front mounting is preferred because the bolts may be tightened fully. It is *important* that recommended baffle openings and mounting hole locations be followed.

FRONT MOUNTING requires a 11" diameter cutout and a 11-9/16" screw circle. Mark baffle opening and screw locations on the blank panel first. Drill the screw holes before cutting the large baffle opening. If 1/4-20 screws are used, four screws are sufficient for secure mounting of the speaker. TEENUTS are recommended for simple, secure mounting. If TEENUTS are used, the holes should be 9/32" or .290" (letter L drill). Apply glue to the flanges of 1/4-20 long shank TEENUTS before driving into the rear of the holes.

Sealing of the front-mounted speaker is accomplished with the adhesive-backed foam gasket segments. Strip off protective paper and apply gasket to the rear mounting surface of the speaker rim, making certain that holes in the gasket line up with the mounting holes in the speaker frame.

Length of the 1/4-20 screws should be 1/2" plus the panel thickness when using TEENUTS. The screws must have fillister heads to seat down in the recess of the speaker frame. Screws should be tightened evenly and securely. Maximum torque possible with a proper size screwdriver should be sufficient.

IMPORTANT! When front mounting, the screw head **must** fit down into the front gasket cutout. See Figure 2.

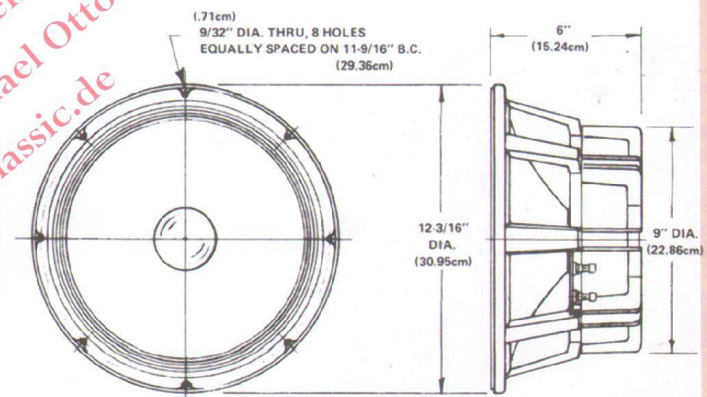

FIGURE 1 - Dimensions

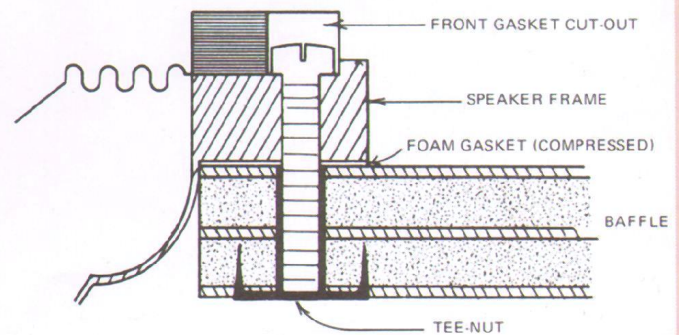

FIGURE 2 - Front Mounting Detail (Not to scale)

REAR MOUNTING requires the same diameter cutout and screw circle as front mounting. Other comments regarding the use of TEENUTS apply to rear mounting as well.

Screw length should be $\frac{3}{4}$ " plus panel thickness if using TEENUTS—longer for standard hex nuts. If hex nuts are used, a second nut should be tightened against the first nut to prevent loosening during operation. A lock washer and flat washer are recommended between the screw head and frame. See Figure 3.

Screws should be tightened evenly, but not excessively. Maximum torque possible with a proper size screwdriver should be sufficient. Do not use adhesive-back gasket segments for rear mounting.

If a cabinet is to be constructed from scratch, $\frac{3}{4}$ -inch solid and jointed or marine plywood is recommended. After construction, be certain interior is completely free of metal filings, wood chips, etc.

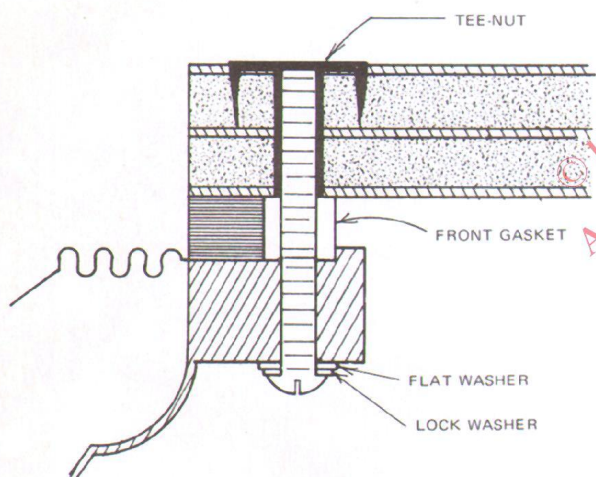

FIGURE 3 – Rear Mounting Detail (Not to scale)

CONNECTIONS

Use No. 18 or larger stranded wire to connect the two terminals on the loudspeaker to the amplifier output. If a choice of amplifier output impedance is available (4, 8, 16 ohms), a single EVM•12L speaker should be connected to the 8-ohm tap. Two EVM•12L speakers may be connected in parallel as shown in Figure 4. Be sure to connect the red terminals together as shown in Figure 4. If series wiring is desired, wiring and polarity should follow Figure 5.

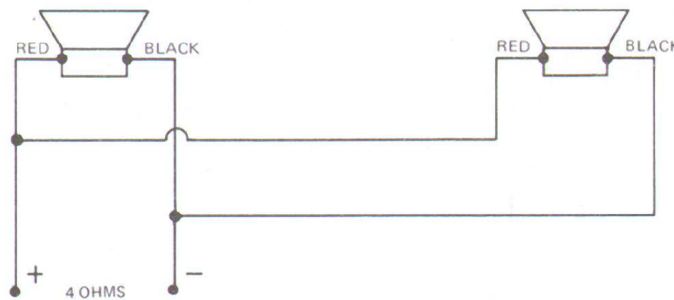

FIGURE 4 – Connection of 2 EVM•12L Speakers in Parallel

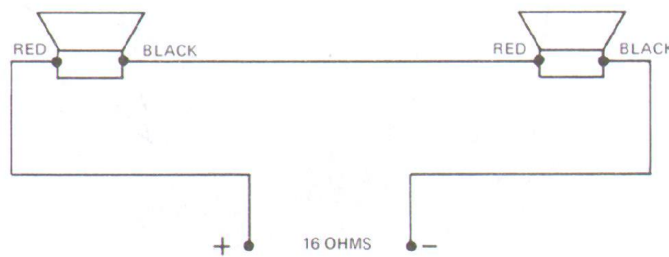

FIGURE 5 – Connection of 2 EVM•12L Speakers in Series

SPECIFICATIONS

Nominal Impedance:	8 ohms
DC Resistance:	5½ ohms ± 10%
Free Air Resonance:	50 Hz ± 10%
Power Handling Capacity:	100 watts continuous sine wave
EIA Sensitivity Rating:	53 dB
Voice Coil Diameter:	2½" (6.35cm)
Magnet Weight:	4 lbs., 13 oz. (2.2kg) ceramic
Magnetic Structure:	16 lbs. (7.2kg)
Dimensions:	12-3/16" (30.95cm) x 6" (15.24cm) deep
Frame Mounting:	Eight 9/32" (.71cm) holes equally spaced on 11-9/16" (29.36cm) circle
Mounting Dimensions, Baffle Opening:	11" (27.94cm) dia.
Mounting Holes:	Four or eight 9/32" (.71cm) holes equally spaced on 11-9/16" (29.36cm) screw circle
Net Weight:	19 lbs. (8.6kg)
Shipping Weight:	23 lbs. (10.4kg)

CUSTOMER SERVICE

EVM•12L speakers are packed to provide maximum protection – well in excess of the shipping requirements of the Interstate Commerce Commission. If shipping damage does occur, contact the carrier immediately, requesting inspection and instructions, or contact the dealer from whom the unit was purchased.

For correct shipping address and instructions on return of Electro-Voice products for repair and locations of authorized service agencies, please write: Service Department, Electro-Voice, Inc., 600 Cecil Street, Buchanan, Michigan 49107 (Phone:616/695-6831).