

Cybernet

ImageTwo RC

AM/FM Stereo Tuner

T2-RC

Service Manual

Contents

Specifications	2
Instruction Information	
Features	3
Installation	3
Tuner Connections	3
Antennas	4
Control Functions	5
Tuner Operations	6
Muting Level Adjustment	6
Trouble Shooting Guide	7
Circuit Description	8
Service Information	
Test Equipment	10
FM Alignment	10
AM Alignment	14
Block Diagram	16
PC Board Layout	17
Exploded View	18
Replacement Parts List	19
Schematic Diagram	30

Specifications

FM Tuner

Frequency range	87.5 to 108.0 MHz
Sensitivity	10.3 dBf (1.8 microvolt IHF '58)
50 dB noise quieting sensitivity	
Mono	16.6 dBf (3.7 microvolt IHF '58)
Stereo	37.2 dBf (39.2 microvolt IHF '58)
Total harmonic distortion	1,000 Hz
Mono	0.10%
Stereo	0.20%
S/N	
Mono	75 dB
Stereo	70 dB
Frequency response	30 to 15,000 Hz +0, -0.5 dB
Alternate channel selectivity	80 dB
Capture ratio	1.2 dB
AM suppression	55 dB
Spurious response rejection at 98 MHz	85 dB
Stereo separation at 1000 Hz	45 dB
Output voltage	0.775V

AM Tuner

Frequency range	531 to 1,602 kHz
Sensitivity	300 microvolt/m
Selectivity	45 dB
Image rejection at 1 MHz	50 dB
S/N	50 dB
Dimensions (W x H x D)	400 mm x 58 mm x 255 mm

Instruction Information

Features

The Cybernet Image-II with Remote Control System is a unique, sophisticated high-fidelity stereo system that combines a high quality separate pre- and main-amplifier R2-RC and A2-RC, a front-loader, logic-controlled stereo cassette deck with Dolby* noise reduction system C2-RC, a high-sensitivity digital PLL synthesized AM/FM tuner T2-RC, and a handy battery-operated remote control transmitter X2-RC.

The model T2-RC is specifically designed to conform with other matching components into a complete stereo system, and almost all functions are duplicated on X2-RC. It features the following.

PLL [Phase-locked-loop] synthesized 50 kHz FM/9 kHz AM digital tuning with either automatic or manual mode.

Micro-computer memory feature for 12 stations for AM and FM.

Dual-element ceramic filters for razor-sharp selectivity in the IF amplifier stage.

PLL multiplex demodulator for stable stereo multiplex performance.

Previously-selected frequency memory for easy access to the previous frequency and mode.

Tuner Connections

Refer to pictorial connection diagram.

Connection to P2-RC. Very Important: Do not turn on main amplifier power switch until all inter-component connections have been completed, or power supply electronics in the main amplifier will be damaged.

The tuner T2-RC is connected to the preamplifier P2-RC by means of two cables terminated with DIN type plugs. No other connections are necessary. These cables feed power and remote control command from the preamplifier to the tuner,

10.3 dBf usable sensitivity.

Almost all functions remote-controllable from X2-RC remote control transmitter.

* TM Dolby Laboratories.

Installation

Installation of your tuner is not complicated. However, the following guidelines must be followed for satisfactory performance and ease of operation of the unit.

Do not remove cover — there are no user serviceable parts inside the unit.

The equipment must not be exposed to excessive dust, moisture, or direct sources of heat or sunlight.

To clean the cabinet, wipe with a cloth soaked in a neutral cleaner or a polishing cloth. Do not use benzine or thinner which will damage the cabinet finish.

and tuner output to the preamplifier input circuit. (1) Connect 8-pin metal-housed plug of the cable [Supply to P2] to the socket [Supply from T2] on the preamplifier rear panel. (2) Connect 6-pin plastic-housed plug of the cable [Remote to P2] to the socket [Remote from T2] on the preamplifier rear panel. **Do not turn on the power switch on the main amplifier until all system connections are completed.**

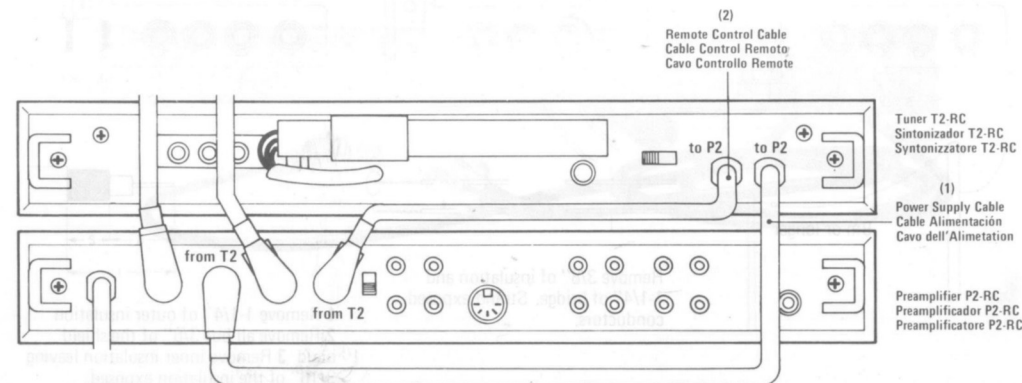

Antennas

Ferrite Loopstick Antenna. The ferrite loopstick antenna is a sensitive pick-up element of the AM tuner section. For maximum station pick-up, it must be properly positioned away from the rear chassis and other metallic surfaces. The associated connecting cables should be dressed as far away as possible. For optimum performance, the antenna should be positioned for maximum signal strength when the unit is tuned to the desired station. Use signal-strength indicator for reference.

External AM Antenna. AM external antenna terminal [ANT-AM] is provided for a properly designed long wire AM antenna system. Such antennas are useful when the desired stations are at a considerable distance from the tuner. A simple long wire antenna can consist of a length of single conductor, insulated wire of 9 meters or longer, extending from the ANT-AM terminal to the outside of the building. This wire should be positioned away from electrical cables and appliances. As a rule, the longer and higher the antenna, the better the reception. However, as signal pick up of broadcast stations is increased so also is the pick up of undesirable man-made interference.

Supplied 300 Ohm FM Dipole. An FM dipole antenna is supplied with your new tuner. In strong signal area, this should be more than adequate for reception of most FM stations. Antenna connections are made to the terminal strip marked ANTENNA-FM-300 Ohm located adjacently to the AM external antenna terminal. The dipole leads are connected to the screws marked 300 Ohm. The ground screw is not used for the dipole antenna. The dipole should be unfolded to its full T-type size and oriented for optimum performance. Dipole

Cable Preparation and Hook-Up

AM Long-Wire Antenna

300 Ohm Twin-Lead

75 Ohm Coaxial Cable

Clamp conductors under screws then secure.

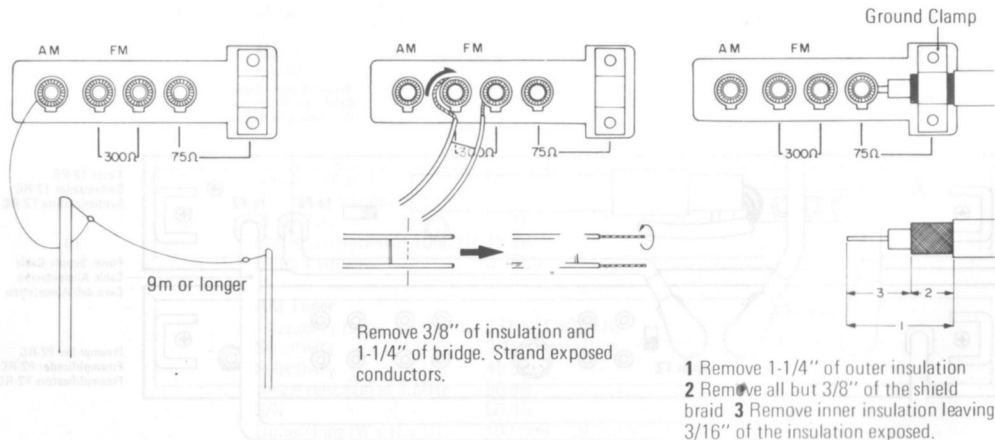

antennas are most sensitive to FM reception when positioned perpendicular to the station.

Exterior 300 Ohm FM Antenna. For fringe [weak signal] areas, or areas where interference to FM reception is high, the use of a log-periodic or Yagi-type antenna system is recommended. These antennas are directional and high gain in nature thus tending to reduce most undesired interference due to reflected signals [multipath distortion] and ignition noise. In areas where stations are located in different directions from the point of reception, the antenna must be positioned for optimum reception of individual stations. For this reason, a good quality rotor is suggested. To minimize the introduction of multipath distortion and ignition interference by the antenna lead-in wires, the use of balanced and shielded 300 Ohm [twin lead] cable is recommended. Unshielded twin-lead is suitable where the lead-in wire length from the antenna is short, and when used it should be twisted at the rate of 5 to 10 turns per meter. Long lead-in wires can act as omnidirectional antenna and can cancel the advantages of directional antenna systems. Shielded 300 Ohm cable consists of two inner signal conductors with an outer shield. An insulating jacket is also provided, covering the shield. The two signal conductors are connected to the screws marked 300 Ohm and the shield is connected to the screw marked Ground.

Exterior 75 Ohm FM Antenna. A second antenna terminal is provided for connecting an unbalanced 75 Ohm antenna cable. This terminal should be used whenever a 75 Ohm coaxial cable is used as a lead-in from the antenna. The braided outer conductor is connected to ground clamp.

Control Functions

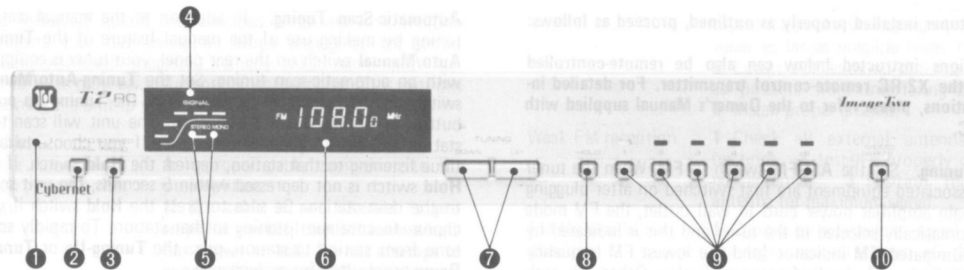

1 Back-Up Indicator. Memory back-up indicator. Lights up even while system power is off.

2 FM/AM Switch. Selects the program source to be received. This selection mode will be automatically memorized so that you will later be able to access to the previous mode of reception when power is turned off and on again.

3 Stereo/Mono Switch. Determines the manner in which a received FM station is reproduced through the tuner. When listening to a stereo FM station, depressing this switch will cause the unit to mix the left and right channel signals detected from the station and reproduce it through both channels monophonically. The released setting of this switch will provide automatic stereo FM reception mode. This is indicated by the illuminated **Stereo** or **Mono** indicator.

4 Signal Strength Indicator. Used for tuning on both AM and FM modes. The stronger the signal received, the more dots are illuminated.

5 Stereo/Mono Indicators. Lights up to indicate the receiving mode in FM reception — stereo or mono. Deactivated in AM mode of reception.

6 Digital Frequency Display. Shows the frequency of a station to which the unit is tuned, directly. Also indicates AM or FM mode and a sign to accept memory presetting [MEMORY].

7 Tuning-Up/Down Pushbuttons. When the **Tuning-Auto/Manual** switch on the rear of the unit is set to the **Auto**, these pushbuttons will start the automatic-scan to a station either upscale or downscale. When the **Tuning-Auto/Manual** switch is set to **Manual** each time depressing either pushbutton will tune the unit to the next available station assignment precisely 50 kHz away for FM, and 9 kHz away for AM.

8 Hold Switch. Used when automatic-scan to stop the scanning at the desired frequency. If the **Hold** switch is not depressed within 5 seconds after the scan has temporarily stopped at a station, the unit will automatically scan to the next station.

9 Memory Pushbuttons. Used for automatic memory pushbutton tuning on AM and FM. Each of 6 pushbutton may be preset to both AM and FM stations.

10 Memory Write Switch. Used when presetting AM and FM stations for automatic pushbutton tuning.



Tuner Operation

With tuner installed properly as outlined, proceed as follows:

Functions instructed below can also be remote-controlled from the X2-RC remote-control transmitter. For detailed information, please refer to the Owner's Manual supplied with X2-RC.

FM Tuning. Set the **AM/FM** switch to **FM**. When the tuner and associated equipment are first switched on after plugging the main amplifier power cord to wall outlet, the FM mode is automatically selected in the tuner and this is indicated by the illuminated **FM** indicator [and the lowest FM frequency will be displayed] on the frequency display. Otherwise, each time you turn on your stereo system, the previous mode and frequency are selected in the tuner automatically. Set the **Tuning-Auto/Manual** switch on the tuner rear panel to **Manual**. Press the **Tuning-Up** pushbutton to tune upscale and press the **Tuning-Down** pushbutton to tune downscale. Each time either pushbutton is depressed, the unit is tuned to the next available FM station assignment precisely 50 kHz away. No fine tuning is necessary. To tune upscale or downscale rapidly, press the either pushbutton and hold it in position. Release the pushbutton when you have tuned to the desired station. If you tune beyond the ends of the scale, the unit tunes automatically to the opposite end and continues.

AM Tuning. Set the **AM/FM** switch to **AM**. When the tuner is first switched on after plugging the main amplifier power cord to the wall outlet, the FM mode is automatically selected in the tuner [and the lowest FM frequency is displayed on the frequency display]. Otherwise, each time you turn on the stereo system, the previous mode and frequency are selected automatically. Set the **Tuning-Auto/Manual** switch to **Manual**. Press the **Tuning-Up** pushbutton to tune upscale, and press the **Tuning-Down** pushbutton to tune downscale. Each time either pushbutton is pressed, the unit is tuned to the next available AM station assignment precisely 9 kHz away. No fine tuning is necessary. To tune upscale or downscale rapidly, press either pushbutton and hold it in position. If you tune beyond the ends of the scale, the unit tunes automatically to the opposite end and continues.

Muting Level Adjustment

One of the normal characteristics of FM is the loud rushing noise heard between stations. The tuner incorporates a special muting circuit which is used to eliminate this noise between stations on FM, so that when tuning over the FM band each station will break through from a background of silence. The muting level which a signal must overcome in order to be heard is adjusted with the **Mute Level** control on the rear of the tuner. To adjust the control first set the **AM/FM** switch to **FM**. Set the **Tuning-Auto/Manual** switch on the rear panel to **Manual**. Press either of the **Tuning-Up/Down** pushbuttons to the frequency in which no FM station is received. Only background noise should be heard in this condition. Rotate

Automatic-Scan Tuning. In addition to the manual station tuning by making use of the manual feature of the **Tuning-Auto/Manual** switch on the rear panel, your tuner is equipped with an automatic-scan tuning. Set the **Tuning-Auto/Manual** switch on the rear panel to **Auto**. Press the **Tuning-Up** pushbutton or **Tuning-Down** pushbutton. The unit will scan to a station and pause on it for 5 seconds. If you choose to continue listening to that station, depress the **Hold** switch. If the **Hold** switch is not depressed within 5 seconds, the unit scans to the next station. Be sure to press the **Hold** switch if you choose to continue listening to that station. To rapidly scan-tune from station to station, press the **Tuning-Up** or **Tuning-Down** pushbutton for each change.

Pushbutton Tuning. Each of six preset pushbuttons may be preset to an AM station and an FM station for automatic pushbutton tuning [6 AM/6 FM; 12 in all]. Set the **AM/FM** switch as desired. Adjust the **Tuning-Up/Down** pushbuttons (and **Hold** switch, if required) for the desired station. Press the **Memory Write** switch. Now the word **Memory** appears on the frequency display area. This is to indicate that the unit is ready to accept presetting the station to memory. Depress one of the preselection pushbuttons. The word **Memory** should disappear. Repeat above steps for each pushbutton. You may later use pushbutton to select the station you wish to hear, by merely depressing it.

If you failed to press the pushbutton within 5 seconds after the **Memory Write** switch is depressed, depress the **Memory Write** switch again.

FM Stereo Reception. When tuned to an FM stereo broadcast, the tuner will automatically switch from mono to stereo operation, provided that the **Stereo/Mono** switch is set to **Stereo**. Stereo broadcasts are indicated by the illuminated **Stereo** indicator in the frequency display area. Maximum reduction of background noise on weak stereo FM stations will be obtained by switching the **Stereo/Mono** switch to **Mono**. This will, of course, put the tuner in a monophonic mode of operation.

the **Mute Level** control counterclockwise fully then slowly clockwise until the background noise [hissing sound] just disappears. In this condition, when tuning over the band [in either manual or auto-scan mode], each station will break-through from a background of silence, and any signal to stop scanning and be heard must now be slightly stronger than the average noise. Clockwise rotation will increase the threshold level which a signal must overcome to be received and only strong signals will be tuned in and be heard at **Max.** position. If you want to tune in very weak stations, set the control fully counterclockwise **Min.**

Trouble Shooting Guide

The following guides are intended as an aid in correcting problems you may encounter when setting up the stereo system. Although suggested remedy might seem quite elementary, it may be sufficient to make corrections without returning the unit to your dealer.

Problem

Tuner inoperative when system power is on.

Indicator(s) lights up but no tuner output.

Weak AM reception.

Suggested Remedy

1 Improper cable connection to the preamplifier.

If the cable is not inserted to pre-amplifier socket, turn off main amplifier power switch. Do not attempt to connect it to preamplifier with system power on.

2 Improper amplifier power plug connection to wall outlet. Check for correct voltage supply.

1 P2-RC preamplifier not selecting the tuner output. Depress **Tuner** switch on the preamplifier. 2 Check for proper cable connection from tuner to preamplifier.

1 Position loopstick antenna for maximum station pick up. 2 Locate tuner away from metal surface. 3 If building construction uses aluminum foil faced insulation, metal lath, or steel framing, AM reception will be poor.

Weak FM reception.

FM Multipath distortion.

Noisy FM reception.

Install external AM antenna. 4 Locate tuner as far as possible from TV set. 5 Locate AM external antenna as far as possible from interfering source. 6 Install proper ground.

1 Check all external antenna connections. 2 Install a properly designed antenna. 3 Position receiving antenna for maximum signal.

1 Caused by a broadcast signal reaching from two directions; #1 directly from transmitter to tuner, #2 the same signal but received as a reflection from a nearby building or other surfaces. Position receiving antenna for minimum distortion [usually maximum signal].

1 Install external antenna. 2 Use shielded lead-in wire. 3 Install proper earth ground. 4 Rotate antenna for maximum signal. 5 Connect power line filters to interfering appliances.

Circuit Description

PLL Frequency Synthesizer

The FM local oscillator is comprised of a transistor Q3, and a tuning circuit including an oscillator coil T4 and tuning capacitor(s) D4 (varicap diode). The transistor Q3 is being oscillated at a frequency of a receive frequency + 10.7 MHz, and its output is applied to the prescaler IC U6 through a buffer transistor Q4. The prescaler U6 counts down the local signal frequency into a lower frequency (1/20) suitable for phase comparison in the PLL circuitry. Thus obtained low frequency is applied to the pin 3 of PLL IC U7 through a buffer amplifier Q8, and the resultant phase error signal developed at pin 10 is applied to the active LPF filter consisting of transistors Q10 and Q11. Finally the filtered error signal is applied to the oscillator tuning capacitor (varicap diode) D4 to correct (or to generate a new) oscillating frequency.

In case of AM local oscillator, the oscillating signal output from the AM oscillator is directly applied to the PLL IC input circuit (pin 3) through a buffer amplifier Q9, and the resultant DC error signal is fed back to the AM oscillator tuning diode D6 also through the LPF filter to correct the oscillator frequency.

FM Tuner

The FM Front end consists of two dual gate FETs and a local oscillator and its buffer. The first FET is used as a FM RF amplifier and the second as a Mixer amplifier. Each gate of the mixer is connected to the RF amplifier output and a local signal injection circuit, respectively. The mixed and resultant IF signals are then led to the IF amplifiers Q5, U1 and U2. The U2 is a multifunction IF system IC including, three stages of limiter/amplifiers, FM quadrature detector, Meter driver, audio mute signal, etc. For further detail of the IC refer to the IC block diagram shown below.

The detected audio outputs (mono or stereo composite signals) are developed at pin 6 of U2 and applied to the pin 2 of MPX decoder IC U5. The decoded left and right channel outputs are obtained at pin 6 and 7 of the same IC and led to the multi-pin connector through low pass filters are one stage(s) of audio amplifier(s).

Block Diagram of IC, U2:

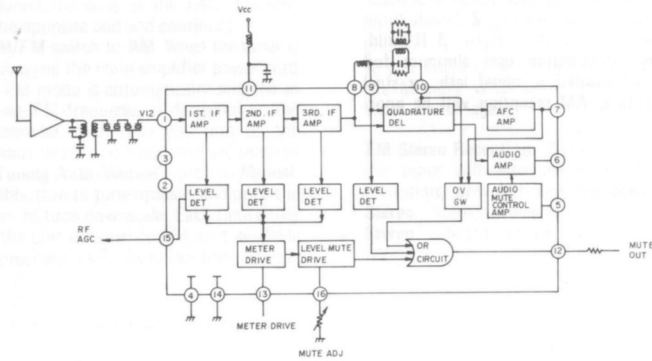

Signal Meter

The IF system IC U2 develops signal meter drive voltage at its pin 13. The drive voltage is led to the base of Q14/Q15 which in turn drives the signal meter LED drivers Q1-Q5, depending on the signal strength received.

Stereo/Mono Switching

The stereo decoder IC U5 operates as a stereo decoder when its pin 16 is applied by a voltage lower than 1.4V. First inverter output (pin 6 of U4), which develops a high output with increased antenna signal input, is connected to the transistor base of Q18 and makes the Q18 conductive when the FM antenna input signal level is increased, then the pin 16 of U5 is grounded through the emitter-collector of Q18, resulting in stereo mode of operation. The pin 9 of U5 develops a low voltage during stereo mode of operation or a high voltage during mono mode operation, and these voltages are used to make the stereo/mono lamps turn on or off.

When FM antenna signals higher than the stereo threshold level is applied to the antenna circuit, the pin 4 of U4 becomes low, and this makes Q13 conductive (common circuit for stereo/mono LEDs).

On the other hand if the U5 operates in stereo mode of operation, the pin 9 develops a low output, then the stereo LED will turn on. However, if the pin 9 develops a high output, the transistor Q22, the base of which is connected to the pin 9, is turned on, then cathode side of the mono LED is grounded through collector-emitter of Q22, thus the mono LED is turned on.

Muting Operation

1. FM Muting

Pin 12 of FM IF system IC develops a positive voltage in the event of a low IF input signal level to drive the muting circuit. The positive voltage is first applied to the first inverter pin 7 of IC U4 and the output is obtained at the second inverter pin 4 (since the first and second inverter is connected in series, the second inverter output is in phase with the first inverter input). The output is then connected to the pin 21 of the controller IC U1. The U1 is designed to develop a logic high voltage at its pin 3 when the pin 21 is applied by a logic high voltage. Since the pin 3 is connected to the base of first muting stage of Q19, the Q19 is turned on in the event of low IF input, and this makes all transistors Q27, Q28, Q30 and Q31 conductive to the ground, thereby muting the audio signals.

2. Muting during Scanning Operation

During scanning operation, the muting circuit is also actuated to eliminate undesirable noises caused by scanning operation. During scanning operation, the controller IC U1 also develops the high level voltage. And the FM circuit will be muted as described just above. On the other hand, in the AM circuit, each base of Q6 and Q7 is supplied from the pin 3 of U1 (logic high) and becomes conductive (namely each RF output and detector output is short-circuited, respectively). Thus the audio outputs will be muted out.

Block Diagram of Stereo MPX Decoder IC, μ PC1173C:

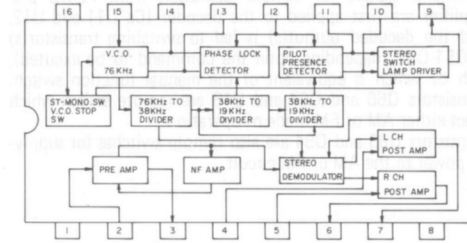

Scan Stop Signal

To secure good scan stop accuracy, the scan stop signal must be narrow and in the center of IF bandwidth. This will be conducted as follows:

As already described, during scanning operation, pin 3 of U1 develops a high voltage, and this is applied to the base of Q65 and makes it conductive, then the FET Q16 is cut off and the resistor connected across the FET is directly connected to R51 in series. The increased resistance (reduced load to the IF circuitry) makes final IF band width narrow. In case of AM operation, a fraction of IF output signal is obtained and further amplified by a narrow band additional IF amplifier consisting of amplifiers provided between pin 9 & 10 and pin 11 & 12 of U4.

The amplified output is rectified by diodes D14 and D15 and the output is led to the inverter provided between the pin 14 and 15 of the same IC. A transistor Q12 also operates as an inverter, the collector of which is connected to the last inverter provided between pin 3 and 2. The output developed at the pin 2 will operate in the similar way as that of pin 4 in case of FM operation.

For connection of the Inverter IC U4, refer to below.

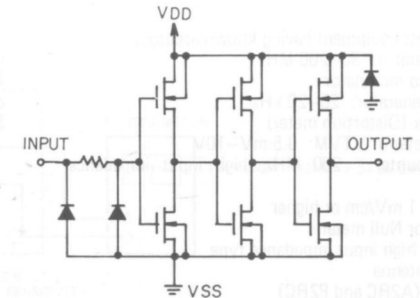
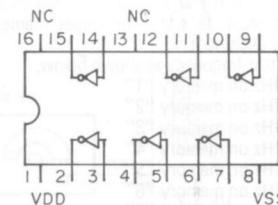

Circuit Description

Remote Operation

Command signals for remote operation from P2-RC pre-amplifier are first applied to the decoder ICs U11 and U12. And the decoded output(s) is fed to switching transistor(s) of Q51-Q62 (depending upon the command to be executed), each of which is equivalent of the manual function switch. Transistors Q66 and Q67 and U13 are remote switch which select either AM or FM mode of operation. Transistors Q63 and Q64 are also remote switches for supplying power to the AM or FM circuit.

AM Tuner Circuit

Most of the AM tuner circuits are integrated in one monolithic IC U3 consisting of a RF amplifier, local oscillator, mixer, detector, meter driver, etc. For detailed information refer to the block diagram shown below. Incoming antenna signals are applied to the pin 1 of U3 and the detected audio output is obtained at pin 12, and the amplified audio output is provided at pin 9. The pin 9 output is split into two and applied to each left and right channel LPF filter circuit in the FM MPX stereo circuits through R99, C104 and R126/128. Transistor Q17, the collector of which is connected to the AM and FM audio signal lines, is also one of AM/FM muting circuit.

Block Diagram of AM Tuner IC:

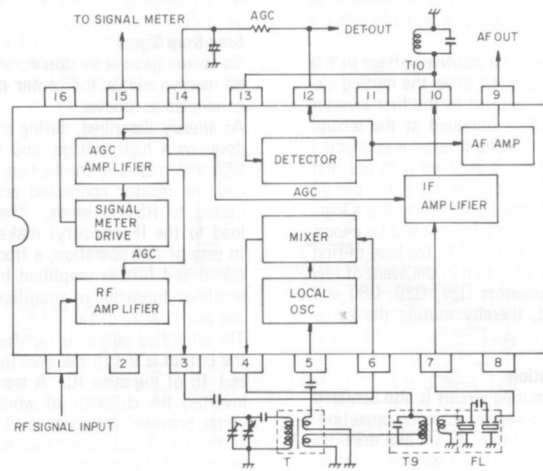

Service Information

Test Equipment

Always use the test equipment having known accuracy.

1. FM signal generator: 30–200 MHz
2. FM MPX stereo modulator
3. Audio signal generator: 20–20 kHz
4. Audio analyzer (Distortion meter)
5. Audio level meter or VTVM: 0.5 mV–10V
6. Frequency counter: 200 MHz, high input impedance type
7. Oscilloscope: 1 mV/cm or higher
8. Center meter or Null meter
9. DC voltmeter, high input impedance type
10. FM dummy antenna
11. Power supply (A2RC and P2RC)

FM Alignment Procedures

Since the tuner has been designed to employ a PLL frequency synthesizer system and electronic tuning circuitry, alignment frequencies must be stored in proper memories before proceeding any alignment.

Store each test frequency as shown below.

- 87.5 MHz on memory "1"
- 90.0 MHz on memory "2"
- 98.0 MHz on memory "3"
- 106.0 MHz on memory "4"
- 108.0 MHz on memory "5"
- 108.0 MHz on memory "6"
- 96.3 MHz on memory "7"

Frequency Storing Method:

Adjust the tuner so that one of test frequency is indicated on the frequency indicator of the tuner by using manual or auto scanning method and UP or DOWN tuning control buttons. When the specified test frequency is obtained, depress the MW (memory write) button, then the specified memory button (1-7).

Repeat the above steps to store all test frequencies on the memories. After completion of storing operation, make sure that each test frequency is stored correctly in the designated memory.

A. PLL Local Oscillator Frequency Circuit Alignment

a) Reference Oscillator Alignment

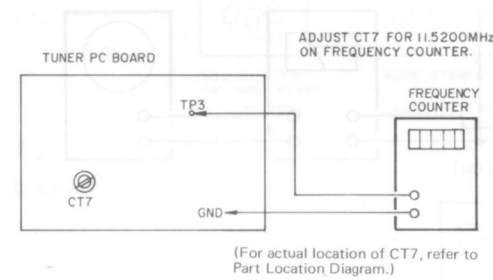

b) Varicap Diode Voltage Alignment

1. Connect a DC voltmeter (high input impedance type) between TP4 and GND on the tuner PC board.
2. Tune the tuner in 108.0 MHz by depressing memory "5" button, then adjust CT4 to obtain 9.6V on the voltmeter.
3. Tune the tuner in 87.5 MHz by depressing memory "1" button, then adjust T4 to obtain 3.1V on the voltmeter.
4. Tune the tuner in 108.0 MHz again and adjust CT4 to obtain 10.0V on the voltmeter.
5. Tune the tuner in 87.5 MHz again and adjust T4 to obtain 3.1V on the voltmeter.
6. Repeat steps 2–5 until 3.1V ± 0.1V is obtained at 87.5V, and 10.0V is obtained at 108.0 MHz.

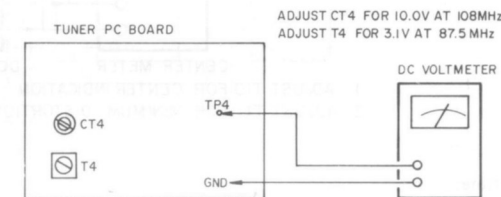

B. IF Circuit Alignment

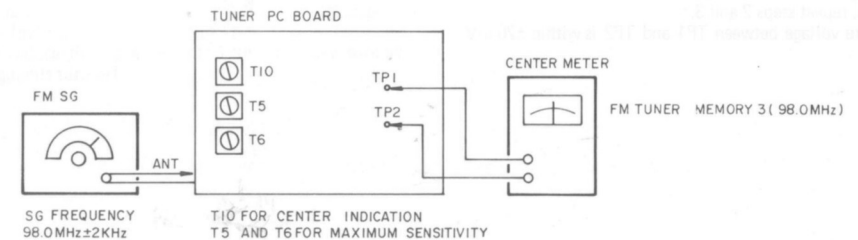

C. FM Front End (Sensitivity) Alignment

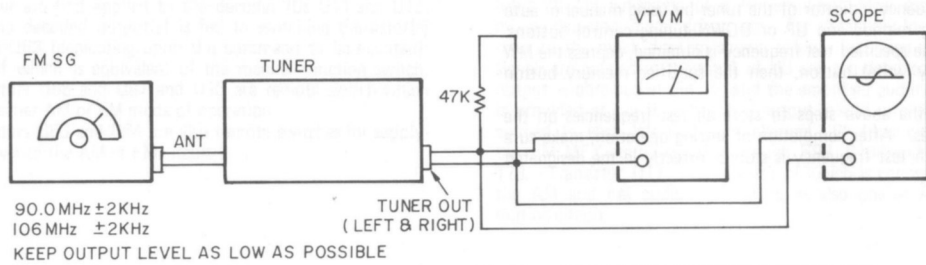

D. Distortion Alignment

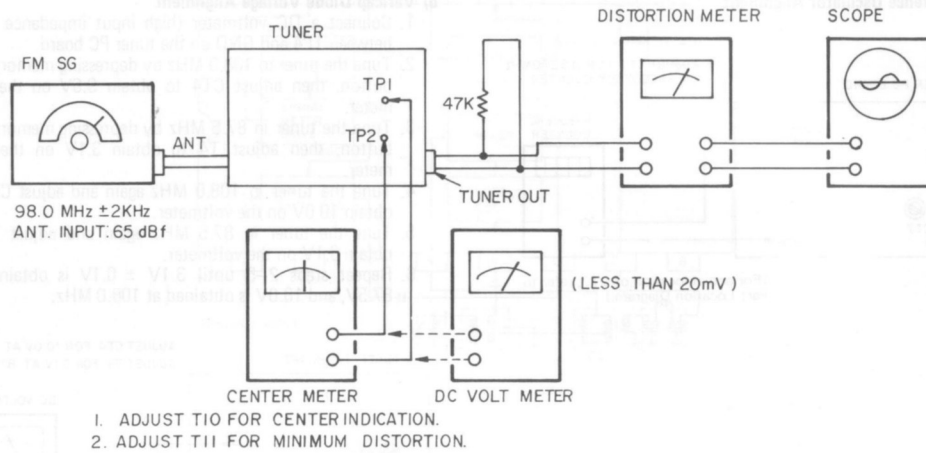

Note:

1. Set signal generator frequency to 98.00 MHz exactly.
2. Center meter should indicate exact center, if not, adjust T10.
3. Adjust T11 for minimum distortion.
4. Adjusting T11 may shift center meter indication, if this is observed, repeat steps 2 and 3.
5. Make sure voltage between TP1 and TP2 is within \pm 20 mV

under no modulation condition. (If the voltage is higher than the specified value, improper auto stop operation may be caused.)

6. Minor center meter deflection from its center under no signal condition may be ignored (no realignment is required).

E. Muting Level Adjustment

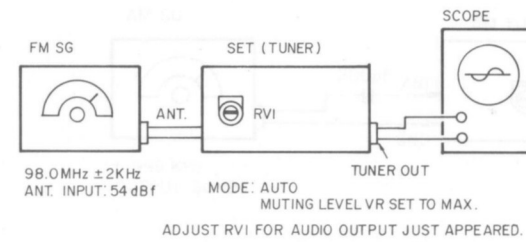

Note:

1. Turn RV1 fully counter clockwise, then slowly turn the RV1 clockwise until an audio output is just obtained on scope display.
2. Next place the Muting Level VR at its mid position, and make sure muting threshold level is about 14–26 dB by decreasing the antenna input signal level.

F. MPX Circuit, 19 kHz Alignment

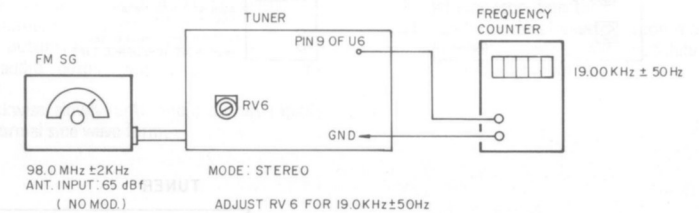

G. Stereo Separation Alignment

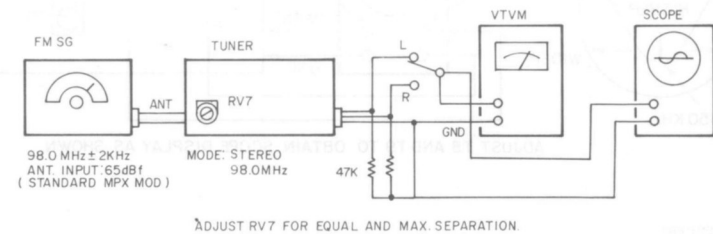

H. Signal Level Meter Alignment

1. Apply 60 dBf antenna input signal to the antenna circuit and adjust RV2 so that all five level meter segments light up.
2. Reduce antenna input signal level to 20 dBf and make sure only the first LED segment light up.
3. Further reduce the signal level to zero and make sure all LED segments turn off.

AM Alignment

Before proceeding any alignment, store test frequencies on the memories in the similar way described in FM Alignment Section.

- 531 kHz on memory "1"
- 603 kHz on memory "2"
- 999 kHz on memory "3"
- 1404 kHz on memory "4"
- 1602 kHz on memory "5"

A. PLL Local Oscillator (Varicap Diode Voltage) Alignment

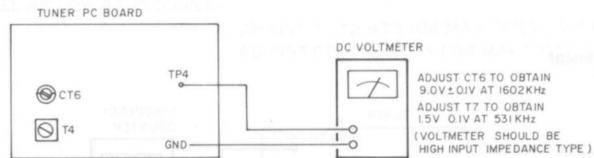

B. IF Alignment

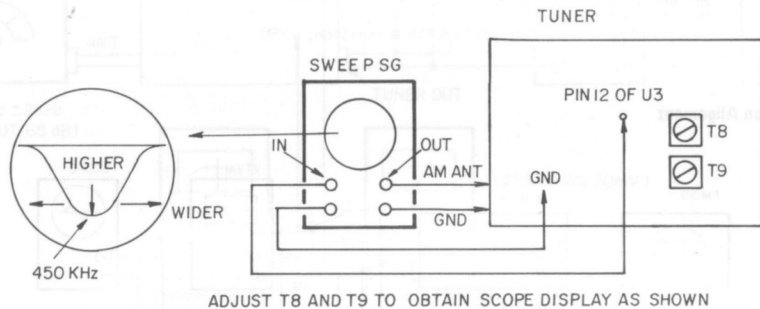

C. AM Sensitivity Alignment

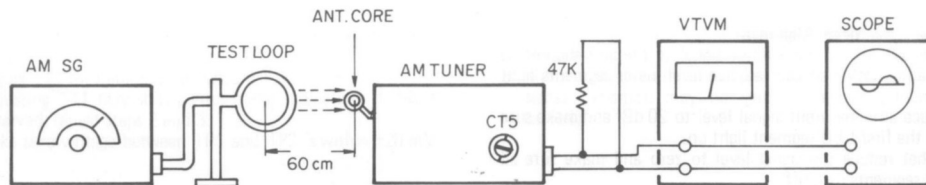

f: 603KHz & 1404KHz
MOD: 30%

1. ADJUST BAR ANTENNA CORE FOR MAX. SENSITIVITY (AUDIO OUTPUT) AT 603 KHz
2. ADJUST CT5 FOR MAX. AUDIO OUTPUT AT 1404KHz

D. AM Sigal Meter Alignment

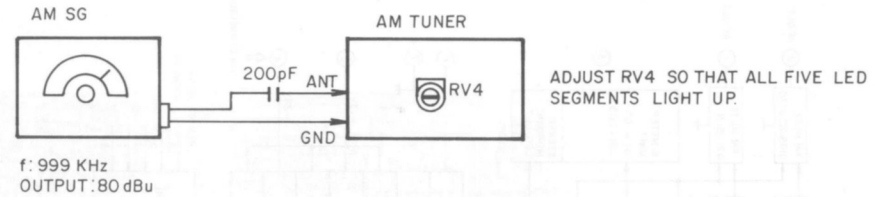

E. Scan Stop Circuit Alignment

1. Use the same test setup used in AM Sensitivity Alignment.
2. Adjust the signal generator to provide 999 kHz, 400 Hz 30% modulation and 57 dB μ /m (SG ATT: 83 dB) and tune the tuner to the same frequency with AUTO mode set.
3. Turn RV5 fully counter clockwise.
4. Depress memory button "3" (999 kHz), and no or distorted (muted) audio output will be observed on the scope display. Adjust RV5 clockwise slowly until audio output rapidly increases with a normal sine wave form.

Note:

- a. The signal generator frequency should be set within 999 kHz \pm 50 Hz because of extra narrow band width of scan stop detector.
- b. Scan stop level depends upon modulation depth and its frequency, so always modulate with 400 Hz, 30% for this alignment.

Block Diagram

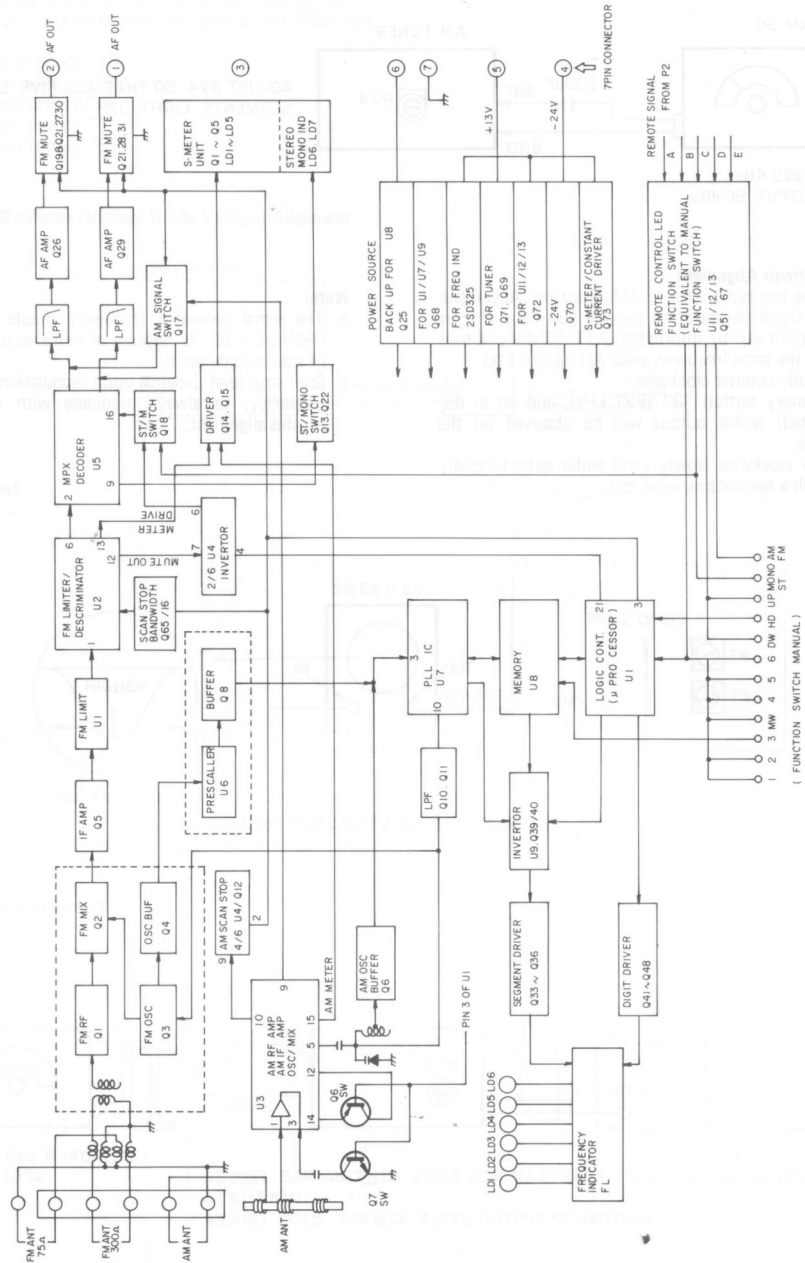

PC Board Layout

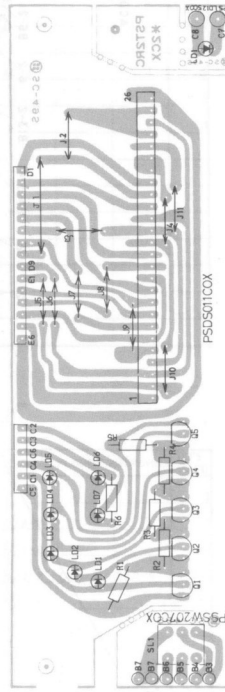
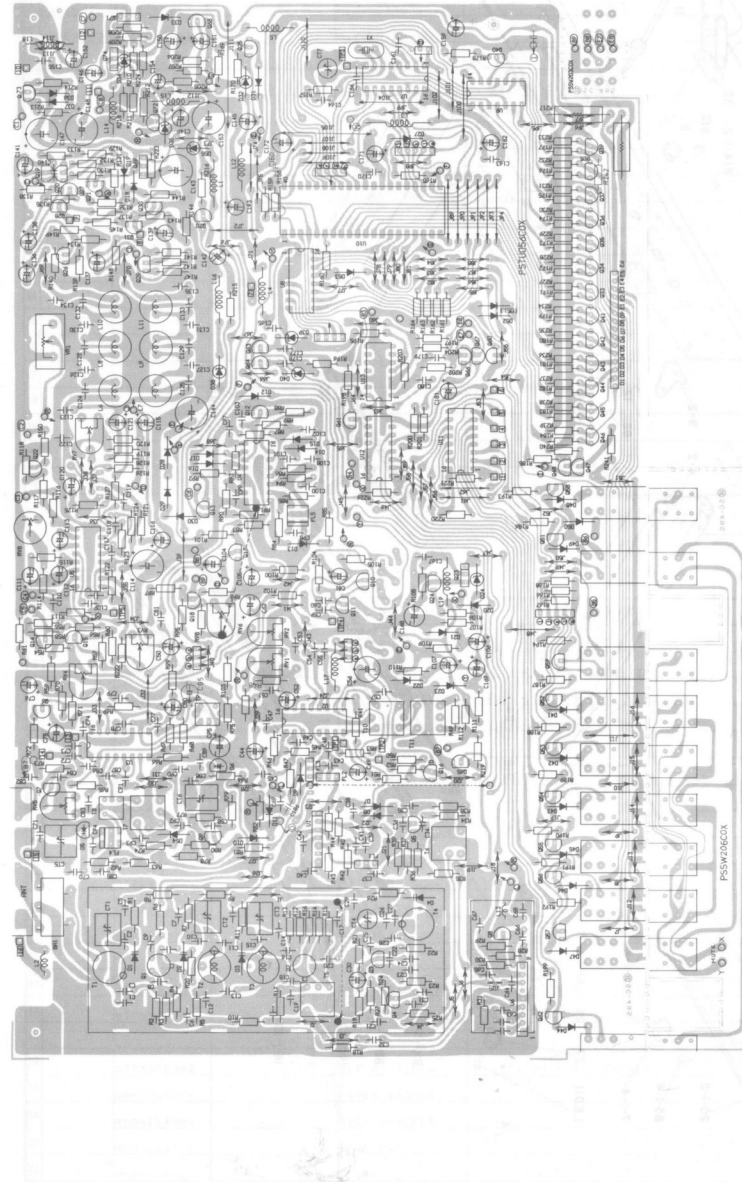

Exploded View

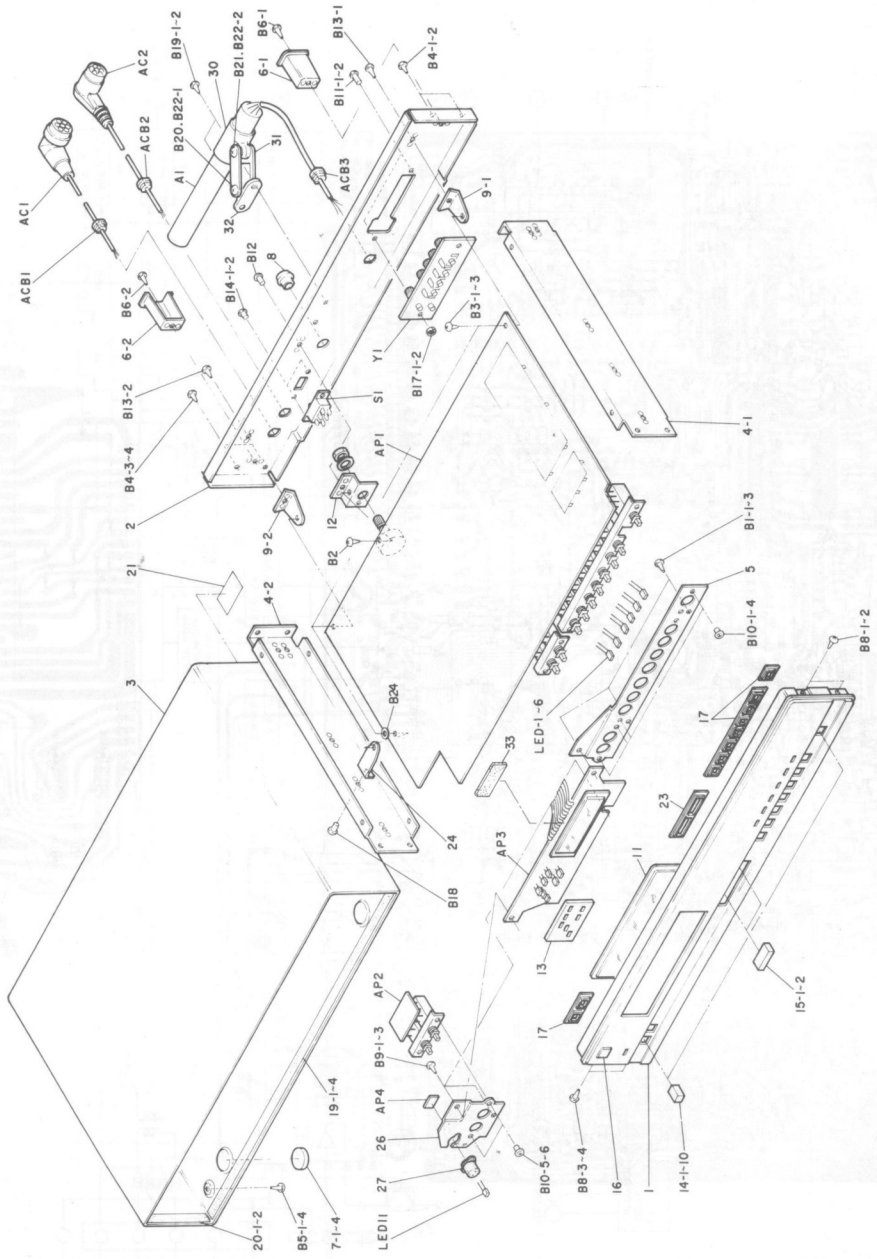

Replacement Parts List

EXPLODED ASSEMBLY	PART NAME		PART CODE	SPECIFICATIONS	SYMBOLIC OR EXPLODED VIEW NO.				QTY USED
	ELEC.	ELEMENTS			PART, STOCK NUMBER	PART NAME	LED1	LED2	
1		ACC N195GEA		COPY. CORD ASSY					1
2		ACD N012GEA		DIN CORD ASSY					1
3	EXPLODED	APST2RC*12		P.W. BOARD ASSY					1
4	EXPLODED	APST2RC*21		P.W. BOARD ASSY					1
5		GT2RC**A02		WIRES KIT					1
6		QLBLN317GN		L.E.D. UN317GP GREEN	LED1	LED2	LED3	LED4	6
7					LED5	LED6			
8		QLBLN417YN		L.E.D. DIODE UN417YP ORANGE	LED11				1
9		550202372N		SLIDE SWITCH	S1				1
10		TEAR120E04		BAR ANTENNA	A1				1
11		VM270NB003		BUSHING	ACB1	ACB2			2
12		VM270NB004		BUSHING	ACB3				1
13		YT0050002Z		ANT TERMINAL	Y1				1
14									
15									
16									
17									
18									
19									
20									
21									

EXPLODED ASSEMBLY	PART NAME		PART CODE	SPECIFICATIONS	SYMBOLIC OR EXPLODED VIEW NO.				QTY USED
	Mech.	ELEMENTS			PART, STOCK NUMBER	PART NAME	B22-1	B22-2	
1	EXPLODED	AMT2RC**01		ESCUTCHEON ASSY					1
2		2NHCL30N5R		HEXA NUT 13, S-BLACK, THIN-TYPE	B22-1	B22-2			2
3		3RP3052WB		PAN HEAD RIVET 3MX5	B11-1	B11-2			2
4		3SPC3006NZ		CEMS SCREW + BIT, M3 X 6 S-ZNCR	B10-1	B10-2	B10-3	B10-4	6
5					B10-5	B10-6			
6		3SPL3005NB		BIND NAIL SCREW + BIT, M3 X 6 S-BLACK	B12	B13-1	B13-2		3
7		3SP3020NB		PAN HEAD SCREW + BIT, M3 X 20 S-BLACK	B20				1
8		3SP3020NP		PAN HEAD SCREW + BIT, M3 X 20 PLASTIC	B21				1
9		3TPL30030R		NAIL TAP SCREW + BIT, M3 X 8 S-BLACK	B4-1	B4-2	B4-3	B4-4	4
10		3TPL30030N		NAIL TAP SCREW	B5-1	B5-2	B5-3	B5-4	4
11		3TPP2606BB		PAN TAP SCREW	B14-1	B14-2			2
12		3TPP3003BZ		PAN TAP SCREW + BIT, M3 X 8 S-ZNCR	B1-1	B1-2	B1-3	B9-1	6
13					B9-2	B9-3			
14		3TPW3008BR		BRAS. TAP SCREW + BIT, M3 X 8 S-BLACK	B19-1	B19-2	B6-1	B6-2	4
15		3TPW3008BZ		BRAS. TAP SCREW + BIT, M3 X 8 S-ZNCR	B18	B8-1	B8-2	B8-3	9
16					B8-4				
17		3TPX3008BZ		I.T UT SCREW + BIT, M3 X 8 S-ZNCR	B2	B3-1	B3-2	B3-3	4
18		3WM30A08FR		FIBER WASHER	B24				1
19		MBB415X003		SIDE BRACKET	4-1	4-2			2
20		MBB51SE005		REAR PANEL					1
21		MBB865M023		COVER					3

EXPLODED ASSEMBLY		PART NAME		PART CODE					
MECH. ELEMENTS		TFA04A54GL2							
REMARKS	PART CODE	PART STOCK NUMBER	PART NAME	SPECIFICATIONS	SYMBOLIC OR EXPLODED VIEW NO.				QTY USED
1	M111XC001		PLATE C.Y.		16				1
2	M4422PB001		HOLDER		32				1
3	M632PB001		HOLDER		31				1
4	M12435X001		PCB BRACKET		24				1
5	M1321SL001		BRACKET PHB		9-1	9-2			2
6	M4430PB001		HOLDER		30				1
7	M5565X001		BRACKET J		26				1
8	M5765X001		BRACKET J		5				1
9	MZ3325Z003		BRACKET VR		12				1
10	VB4325B001		SUPPORT		6-1	6-2			2
11	VF1525X002		BUTTON GUIDE		23				1
12	VF1725X004		BUTTON GUIDE		17-1	17-2			2
13	VM165RB005		BUSHING		27				1
14	VN211SM009		BUTTON A		14-1	14-10	14-2	14-3	10
15					14-4	14-5	14-6	14-7	
16					14-8	14-9			
17	VN221SM010		BUTTON A		15-1	15-2			2
18	VN2765B023		KNOR VR		9				1
19	V5515YB001		SHEET		20-1	20-2			2
20	V5709YF031		FOJT		7-1	7-2	7-3	7-4	4
21	V5738AK001		PLATE		11				1

EXPLODED ASSEMBLY		PART NAME		PART CODE							
MECH. ELEMENTS		P...DARD ASSY		AP705011AA							
REMARKS	PART CODE	PART STOCK NUMBER	PART NAME	SPECIFICATIONS	SYMBOLIC OR EXPLODED VIEW NO.				QTY USED		
1	M451CX009		SHIRT JUMPER						1		
2	P505011CX9		PRINTED CIRCARD						1		
3	P5T28C02CX		PRINTED CIRCARD						1		
4	QLBLN217R4		L.S.D.	LN217R RED			LED7		1		
5	QLBLN317G4		L.S.D.	LN317GP GREEN			LED1	LED2	LED3	LED4	6
6							LED5	LED6			
7	JTC1685XAN		TRANSISTOR	25C1685 Q,P-RAWK	Q1	Q2	Q3	Q4		5	
8							Q5				
9	RD25PJ472X		CARBON FILM R.	0.254 4.7K OHM 5%	R2	R4	R5			3	
10	RD25TJ472X		CARBON FILM R.	0.254 4.7K OHM 5%	R1	R3				2	
11	V5427RB001		FL SPONGE		33					1	
12	V5439RB002		SPNGE LED		13					1	
13	WPO7120DGT		PC-JOINT		JU1					1	
14	WPO8120DGT		PC-JOINT		JU2					1	
15	WUG137EEEX		HI-WRAP WIRE		NO1					1	
16	WUG245EEEX		HI-WRAP WIRE		NO2					1	
17	WUG348EEEX		HI-WRAP WIRE		NO3					1	
18	WUG450EEEX		HI-WRAP WIRE		NO4					1	
19	WUG550EEEX		HI-WRAP WIRE		NO5					1	
20	WUG657EEEX		HI-WRAP WIRE		NO6					1	
21	ZLFLP709XA		F.L. INDICATOR		LT1					1	

EXPLODED ASSEMBLY		PART NAME		PART CODE						
MECH. ELEMENTS		TFA04A55CL2								
REMARKS	PART CODE	PART STOCK NUMBER	PART NAME	SPECIFICATIONS	SYMBOLIC OR EXPLODED VIEW NO.				QTY USED	
1	V5815YB001		SHEET		19-1	19-2	19-3	19-4		4
2	VVL611GE08		LABEL		21					1
3	VVL611GE05		LABEL		34					1
4	ZAT0015002		ANTENNA							1
5	KPT28C*E01		INNER CARTON							1
6										
7										
8										
9										

EXPLODED ASSEMBLY		PART NAME		PART CODE						
MECH. ELEMENTS		P...DARD ASSY		APSTU036MD						
REMARKS	PART CODE	PART STOCK NUMBER	PART NAME	SPECIFICATIONS	SYMBOLIC OR EXPLODED VIEW NO.				QTY USED	
1	CC08040C0M		CERAMIC CAP.	SL 4PF 50V -0.25, +0.25PF	C28					1
2	CC08050C0M		CERAMIC CAP.	SL 5PF 50V -0.25, +0.25PF	C166					1
3	CC030700CM		CERAMIC CAP.		C26					1
4	CC030700DM		CERAMIC CAP.	SL 7PF 50V -0.5, +0.5PF	C1					1
5	CC031000CM		CERAMIC CAP.	GH 10PF 50V -0.5, +0.5PF	C23					1
6	CC031000DM		CERAMIC CAP.		C25					1
7	CC031000DM		CERAMIC CAP.	SL 10PF 50V -0.5, +0.5PF	C31					1
8	CC031200KM		CERAMIC CAP.	12PF 50V -10, +10% SL	C11	C14				2
9	CC032200KM		CERAMIC CAP.	22PF 50V -10, +10% SL	C16					1
10	CC033300KM		CERAMIC CAP.	33PF 50V -10, +10% GH	C22					1
11	CC034710KM		CERAMIC CAP.	470PF 50V -10, +10% SL	C29					1
12	CC0351K0T		CERAMIC CAP.	150PF 50V -10, +10% SL	C92					1
13	CC03221K0T		CERAMIC CAP.	220PF 50V -10, +10% SL	C59					1
14	CC030300GT		CERAMIC CAP.	SL 3PF 50V -0.25, +0.25PF	C89					1
15	CC03101K0T		CERAMIC CAP.	100PF 50V -10, +10% SL	C117	C140				2
16	CC03220K0T		CERAMIC CAP.	22PF 50V -10, +10% SL	C98					1
17	CC03270K0T		CERAMIC CAP.	27PF 50V -10, +10% SL	C43	C69				2
18	CC03330K0T		CERAMIC CAP.	33PF 50V -10, +10% SL	C164	C48				2
19	CC03470K0T		CERAMIC CAP.	47PF 50V -10, +10% SL	C73					1
20	CC03560K0T		CERAMIC CAP.	56PF 50V -10, +10% SL	C32	C94				2
21	CC03920K0T		CERAMIC CAP.	82PF 50V -10, +10% SL	C68					1

EXPLODED ASSEMBLY		PART NAME		PART CODE						
MECH. ELEMENTS		AMTAC06C1								
REMARKS	PART CODE	PART STOCK NUMBER	PART NAME	SPECIFICATIONS	SYMBOLIC OR EXPLODED VIEW NO.				QTY USED	
1	M360AM005		ESCUTCHEON		1-D					1
2	M360AX001		ESCUTCHEON		1-A					1
3	M360AX012		ESCUTCHEON		1-C					1
4	M360AX022		ESCUTCHEON		1-E					1
5										
6										
7										
8										
9										

EXPLODED ASSEMBLY		PART NAME		PART CODE							
REMARKS		PART CODE	PART STOCK NUMBER	PART NAME	SPECIFICATIONS	SYMBOLIC OR EXPLODED VIEW NO.				QTY USED	
1		CEAC221ALX		ELYT. CAPACITOR	220MFD 10V	C159					1
2		CEAD221ALX		ELYT. CAPACITOR	220MFD 15V	C114	C142	C30			3
3		CEA3470ALX		ELYT. CAPACITOR	47MFD 16V	C95					1
4		CEAD471ALX		ELYT. CAPACITOR	470MFD 16V	C143	C148				2
5		CEAGR222M		ELYT. CAPACITOR	0.22MFD 50V MS	C113					1
6		CEA52K2ALX		ELYT. CAPACITOR	2.2MFD 50V	C169					1
7		CEAG221ALX		ELYT. CAPACITOR	220MFD 50V	C187					1
8		CEAG470ALX		ELYT. CAPACITOR	47MFD 50V	C188					1
9		CEVC220ALX		ELYT. CAPACITOR		C162					1
10		CEVC221ALX		ELYT. CAPACITOR		C144					1
11		CEVC470ALX		ELYT. CAPACITOR		C145	C149	C150			3
12		CEV3100ALX		ELYT. CAPACITOR		C105	C115	C116	C120		8
13		CEV0101ALX		ELYT. CAPACITOR		C121	C52	C75	C76		1
14		CEV0470ALX		ELYT. CAPACITOR		C56					1
15		CEV0470ALX		ELYT. CAPACITOR		C168	C62				2
16		CEVE3R3ALX		ELYT. CAPACITOR		C111					1
17		CEVE474ALX		ELYT. CAPACITOR		C104	C136	C137	C138		9
18						C139	C152	C44	C50		
19						C80					
20		CEVE470ALX		ELYT. CAPACITOR		C153					1
21		CEV3474ALX		ELYT. CAPACITOR		C146	C151	C171			3

EXPLODED ASSEMBLY		PART NAME		PART CODE							
REMARKS		PART CODE	PART STOCK NUMBER	PART NAME	SPECIFICATIONS	SYMBOLIC OR EXPLODED VIEW NO.				QTY USED	
1		CKF3472ZFT		CERAMIC CAP.	4700PF 50V -20, +80% F	C36	C66				2
2		CKF8473ZFT		CERAMIC CAP.	0.047MFD 50V -20, +80% F	C109	C154	C155	C163		18
3						C165	C170	C173	C177		
4						C178	C51	C53	C54		
5						C55	C57	C65	C82		
6						C86	C93				
7		CKGB102ZFT		CERAMIC CAP.	1000PF 50V -20, +80% F	C190					1
8		CKGB681KBT		CERAMIC CAP.		C134	C135				2
9		QOMB102KTH		MYLAR CAPACITOR	1000PF 50V -10, +10%	C122	C123				2
10		QOMB103KEH		MYLAR CAPACITOR	0.01MFD 50V -10, +10%	C77					1
11		QOMB152KTH		MYLAR CAPACITOR		C130	C131				2
12		QOMB222KTH		MYLAR CAPACITOR	2200PF 50V -10, +10%	C126	C127				2
13		QOMB333KTH		MYLAR CAPACITOR	0.033MFD 50V -10, +10%	C179	C60				2
14		QOMB683KEH		MYLAR CAPACITOR	0.068MFD 50V -10, +10%	C103					1
15		QOSC102JCF		STYROFLEX CAP.		C128	C129				2
16		QOSC122JCF		STYROFLEX CAP.		C118	C119				2
17		QOSC182JCF		STYROFLEX CAP.	1800PF 100V -5, +5%	C132	C133				2
18		QOSC251JCF		STYROFLEX CAP.		C124	C125				2
19		QOSC471JCF		STYROFLEX CAP.	470PF 100V -5, +5%	C110	C90				2
20		CTX1080P06		TRIMMER CAP.		CT1	CT2	CT3	CT6		4
21		CTX1150P01		TRIMMER CAP.		CT5					1

EXPLODED ASSEMBLY		PART NAME		PART CODE							
REMARKS		PART CODE	PART STOCK NUMBER	PART NAME	SPECIFICATIONS	SYMBOLIC OR EXPLODED VIEW NO.				QTY USED	
1		CEVG010ALX		ELYT. CAPACITOR		C106	C107	C112	C141		7
2						C181	C49	C61			
3		CG2H3R4KPB		MINIC CAP.		C20					1
4		CKD8102ZF4		CERAMIC CAP.	1000PF 50V -20, +80% F	C3	C8				2
5		CKD1103ZF4		CERAMIC CAP.	0.01MFD 50V -20, +80% F	C10	C12	C13	C15		13
6						C167	C18	C2	C24		
7						C27	C4	C5	C6		
8						C7					
9		CKD1223ZF4		CERAMIC CAP.	0.022MFD 50V -20, +20% F	C17	C185	C19	C21		4
10		CKD1472ZF4		CERAMIC CAP.	4700PF 50V -20, +80% F	C9					1
11		CKD1473ZF4		CERAMIC CAP.	0.047MFD 50V -20, +20% F	C160	C186				2
12		CKF1103ZFT		CERAMIC CAP.	0.01MFD 50V -20, +80% F	C101	C161	C34	C64		11
13						C67	C72	C81	C83		
14						C84	C85	C91			
15		CKF1152KBT		CERAMIC CAP.		C63					1
16		CKF8223ZFT		CERAMIC CAP.	0.022MFD 50V -20, +80% F	C100	C102	C35	C37		20
17						C38	C39	C40	C41		
18						C42	C45	C46	C47		
19						C70	C74	C78	C79		
20						C88	C88	C97	C99		
21		CKF8332KBT		CERAMIC CAP.	3300PF 50V -10, +10% B	C58					1

EXPLODED ASSEMBLY		PART NAME		PART CODE							
REMARKS		PART CODE	PART STOCK NUMBER	PART NAME	SPECIFICATIONS	SYMBOLIC OR EXPLODED VIEW NO.				QTY USED	
1		CTZ6100H01		TRIMMER CAP.		CT4					1
2		CTZ6300H01		TRIMMER CAP.		CT7					1
3		FBR450A01M		CERAMIC FILTER		F14	F15				2
4		FB10R7F17M		CERAMIC FILTER		F11					1
5		FB10R7F19M		CERAMIC FILTER		F12	F13				2
6		LCADA3038A		RF COIL		L1	L12	L14	L15		11
7						L16	L17	L18	L19		
8						L3	L4	L5			
9		LF151KA01T		R.F.C.		L2					1
10		LF180JC01K		RF COIL		L13					1
11		LF333JC01K		CHOKE COIL		L10	L11				2
12		LF563JC01K		RF COIL		L8	L9				2
13		LF681KA01S		FERRITE IND.		L20					1
14		LF683JC01K		CHOKE COIL		L6	L7				2
15		MB531S0001		SHIELD COVER		SL1	SL6				2
16		MB532S0001		SHIELD CASE		SL4					1
17		MB751S0002		SHIELD CASE C		SL3					1
18		MB753S0002		SHIELD CASE B		SL2					1
19		MS755S0001		SHIELD CASE		SL5					1
20		MW401CX005		SHORT JUMPER	JW-15						16
21		MW401CX008		SHORT JUMPER							1

EXPLODED ASSEMBLY	PART NAME		PART CODE		REMARKS	PART CODE	PART, STOCK NUMBER	PART NAME	SPECIFICATIONS	SYMBOLIC OR EXPLODED VIEW NO.				QTY USED
	P.W. BOARD ASSY	APSTU055D												
1														
2														
3														
4														
5														
6														
7														
8														
9														
10														
11														
12														
13														
14														
15														
16														
17														
18														
19														
20														
21														

EXPLODED ASSEMBLY	PART NAME		PART CODE		REMARKS	PART CODE	PART, STOCK NUMBER	PART NAME	SPECIFICATIONS	SYMBOLIC OR EXPLODED VIEW NO.				QTY USED
	P.W. BOARD ASSY	APSTU055D												
1														
2														
3														
4														
5														
6														
7														
8														
9														
10														
11														
12														
13														
14														
15														
16														
17														
18														
19														
20														
21														

EXPLODED ASSEMBLY	PART NAME		PART CODE		REMARKS	PART CODE	PART, STOCK NUMBER	PART NAME	SPECIFICATIONS	SYMBOLIC OR EXPLODED VIEW NO.				QTY USED
	P.W. BOARD ASSY	APSTU055D												
1														
2														
3														
4														
5														
6														
7														
8														
9														
10														
11														
12														
13														
14														
15														
16														
17														
18														
19														
20														
21														

EXPLODED ASSEMBLY	PART NAME		PART CODE		REMARKS	PART CODE	PART, STOCK NUMBER	PART NAME	SPECIFICATIONS	SYMBOLIC OR EXPLODED VIEW NO.				QTY USED
	P.W. BOARD ASSY	APSTU055D												
1														
2														
3														
4														
5														
6														
7														
8														
9														
10														
11														
12														
13														
14														
15														
16														
17														
18														
19														
20														
21														

EXPLODED ASSEMBLY	PART NAME		PART CODE		REMARKS	PART CODE	PART STOCK NUMBER	PART NAME	SPECIFICATIONS	SYMBOLIC OR EXPLODED VIEW NO.				QTY USED
	P.W. BOARD ASSY	APSTU056BD								R101	R119	R122	R130	
1														
2														
3														
4														
5														
6														
7														
8														
9														
10														
11														
12														
13														
14														
15														
16														
17														
18														
19														
20														
21														

EXPLODED ASSEMBLY	PART NAME		PART CODE		REMARKS	PART CODE	PART STOCK NUMBER	PART NAME	SPECIFICATIONS	SYMBOLIC OR EXPLODED VIEW NO.				QTY USED
	P.W. BOARD ASSY	APSTU056BD								R109	R110	R111		
1														
2														
3														
4														
5														
6														
7														
8														
9														
10														
11														
12														
13														
14														
15														
16														
17														
18														
19														
20														
21														

EXPLODED ASSEMBLY	PART NAME		PART CODE		REMARKS	PART CODE	PART STOCK NUMBER	PART NAME	SPECIFICATIONS	SYMBOLIC OR EXPLODED VIEW NO.				QTY USED
	P.W. BOARD ASSY	APSTU056BD								R10	R18	R222	R35	
1														
2														
3														
4														
5														
6														
7														
8														
9														
10														
11														
12														
13														
14														
15														
16														
17														
18														
19														
20														
21														

EXPLODED ASSEMBLY	PART NAME		PART CODE		REMARKS	PART CODE	PART STOCK NUMBER	PART NAME	SPECIFICATIONS	SYMBOLIC OR EXPLODED VIEW NO.				QTY USED
	P.W. BOARD ASSY	APSTU056BD								RV2				
1														
2														
3														
4														
5														
6														
7														
8														
9														
10														
11														
12														
13														
14														
15														
16														
17														
18														
19														
20														
21														

EXPLODED ASSEMBLY		PART NAME		PART CODE			
		P+V+BOARD ASSY		APSTU056BD			
1	REMARKS	PART CODE	PART, STOCK NUMBER	PART NAME	SPECIFICATIONS	SYMBOLIC OR EXPLODED VIEW NO.	QTY USED
1		W5G520AAAA		SHIELDED WIRE		N025	1
2		WUGP16EEXX		HI-WRAP WIRE		N022	1
3		WUG119EEXX		HI-WRAP WIRE		N09	1
4		WUG211EEXX		HI-WRAP WIRE		N01	1
5		WUG227EEXX		HI-WRAP WIRE		N010	1
6		WUG312EEXX		HI-WRAP WIRE		N02	1
7		WUG318EEXX		HI-WRAP WIRE		N011	1
8		WUG410EEXX		HI-WRAP WIRE		N012	1
9		WUG415EEXX		HI-WRAP WIRE		N03	1
10		WUG510EEXX		HI-WRAP WIRE		N04	1
11		WUG515EEXX		HI-WRAP WIRE		N019	1
12		WUG616EEXX		HI-WRAP WIRE		N05	1
13		WUG620EEXX		HI-WRAP WIRE		N014	1
14		WUG713EEXX		HI-WRAP WIRE		N016	1
15		WUG716EEXX		HI-WRAP WIRE		N06	1
16		WUG809EEXX		HI-WRAP WIRE		N07	1
17		WUG913EEXX		HI-WRAP WIRE		N017	1
18		WUG907EEXX		HI-WRAP WIRE		N020	1
19		WUG913EEXX		HI-WRAP WIRE		N019	1
20		WUG919EEXX		HI-WRAP WIRE		N09	1
21		WUG924EEXX		HI-WRAP WIRE		N021	1

EXPLODED ASSEMBLY		PART NAME		PART CODE			
		P+V+BOARD ASSY		APSTU056BD			
1	REMARKS	PART CODE	PART, STOCK NUMBER	PART NAME	SPECIFICATIONS	SYMBOLIC OR EXPLODED VIEW NO.	QTY USED
1		WUG713EEXX		HI-WRAP WIRE		N023	1
2		XAZ184001X		CRYSTAL OSCILLATOR		K1	1
3							
4							
5							
6							
7							
8							
9							

EXPLODED ASSEMBLY		PART NAME		PART CODE			
		P+V+BOARD ASSY		AP55R2J3AA			
1	REMARKS	PART CODE	PART, STOCK NUMBER	PART NAME	SPECIFICATIONS	SYMBOLIC OR EXPLODED VIEW NO.	QTY USED
1		P55R2J3CGX		PRINTED BOARD			1
2		SP02CEK32A		PUSH SWITCH		S1	1
3		WUGH45EEXX		HI-WRAP WIRE		N03	1
4		WUG446EEXX		HI-WRAP WIRE		N04	1
5		WUG729EEXX		HI-WRAP WIRE		N01	1
6		WUG824EEXX		HI-WRAP WIRE		N02	1
7							
8							
9							

EXPLODED ASSEMBLY		PART NAME		PART CODE			
		P+V+BOARD ASSY		APST2RC021			
1	REMARKS	PART CODE	PART, STOCK NUMBER	PART NAME	SPECIFICATIONS	SYMBOLIC OR EXPLODED VIEW NO.	QTY USED
1	EXPLODED	AP505011AA		P+V+BOARD ASSY			1
2	EXPLODED	AP5L0125AA		P+V+BOARD ASSY			1
3							

EXPLODED ASSEMBLY		PART NAME		PART CODE			
		P+V+BOARD ASSY		APST2RC010			
1	REMARKS	CYBERNET PART CODE	CUSTOMER'S PART, STOCK NUMBER	PART NAME	SPECIFICATIONS	SYMBOLIC OR EXPLODED VIEW NO.	QTY USED
1	EXPLODED	AP55R2J3AA		P+V+BOARD ASSY			1
2	EXPLODED	APSTU056BD		P+V+BOARD ASSY			1
3							

EXPLODED ASSEMBLY		PART NAME		PART CODE			
		P+V+BOARD ASSY		AP5L0125AA			
1	REMARKS	PART CODE	PART, STOCK NUMBER	PART NAME	SPECIFICATIONS	SYMBOLIC OR EXPLODED VIEW NO.	QTY USED
1		P5L0125CGX		PRINTED BOARD			1
2		WUG230EEXX		HI-WRAP WIRE		N02	1
3		WUG720EEXX		HI-WRAP WIRE		N01	1
4							
5							
6							
7							
8							
9							

Cybernet Electronics Corporation

Cybernet Europe S.A.

Mercure Centre
Raketstraat 100
B-1130 Brussels
Belgium

Tel. 02-720, 90, 20

Cybernet International Inc.

7 Powder Horn Drive
Warren, New Jersey 07060
U.S.A.

Tel. (201) 560-0060

Head Office

344 Shinsaku
Takatsu-ku
Kawasaki
Kanagawa 213
Japan

Tel. 044 (888) 1111

 **Cybernet**