

Cybernet

CR 80S

Service Manual

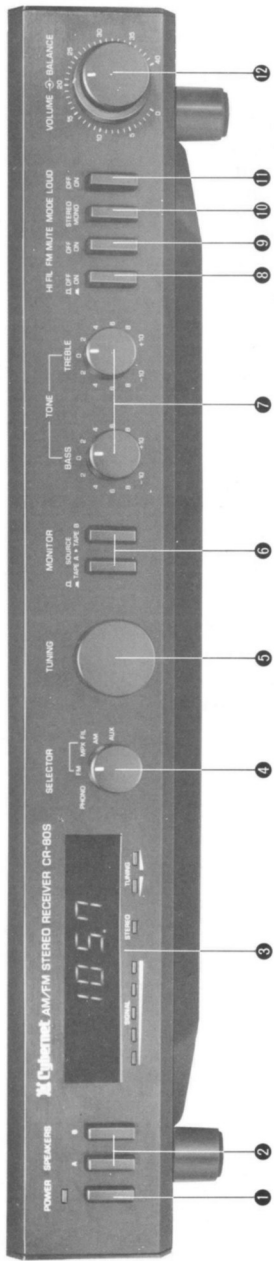

FEATURES

The Cybernet model CR-80S is an integrated stereo receiver with OC power stage delivering $\pm 0.1\%$ THD (2 x 40 Watt RMS) to 8 Ohm loads. The frequency readout device utilizing large light emitting diode which permits you to know easily and instantly the station frequency your receiver is tuned in, even at adverse illumination environment. In addition, it offers following other features:

- "Flat-low" height, that allows associated equipment, usually a record player, be placed on it, without imposing difficulty of installation.
- Input for stereo turntable with magnetic cartridge
- Stereo input to accept any of the high level auxiliary sources
- Tape deck inputs and outputs that permit connection of two of any type tape deck or players, two or three head deck, cassette deck, or 8-track cartridge player
- LED indication for signal strength, stereo broadcast identification, and FM center tuning
- Outputs and switching for one or two pairs of loudspeakers.

SPECIFICATIONS

AMPLIFIER SECTION

Power Output
16.5 dBW (45 watt) RMS, both channels driven 20 Hz to 20 kHz, min., THD 8 Ohm load at 234 Volt AC

Total Harmonic Distortion

$<0.05\%$ at half power
 $<0.1\%$ at rated power

Intermodulation Distortion

$<0.1\%$ at rated power

Frequency Response

± 1 dB 20 Hz to 20 kHz

Power Bandwidth

10 Hz — 35,000 Hz —3 dB

Input Sensitivity

Phono: 2.5 mV 47 KOhm
Other input: 150 mV 47 KOhm

Signal to hum and noise ratio

Phono: 70 dB IHF — A shorted
Other input: 90 dB

Phono headroom (max. input voltage)

35.6 dB (60 times)

Tone control

bass: ± 10 dB at 100 Hz
treble: ± 10 dB at 10 kHz

Loudness filter

+10 dB at 100 Hz Volume control at -30 dB
+3.5 dB at 10 kHz

High-cut filter

-10 dB at 10 kHz

Crosstalk

>60 dB 1 kHz

Damping factor

>40 8 Ohm 1 kHz

Protection

Electronic by relay

TUNER SECTION

FM Section

Sensitivity D1N

mono: <0.9 μ V 75 Ω , 26 dB S/N

stereo: <15 μ V 46 dB S/N

Sensitivity IHF

mono: <11.2 dBf, 30 dB S/N

stereo: <20 dBf, 30 dB S/N

mono: <18.3 dBf, 50 dB S/N

stereo: <38 dBf, 50 dB S/N

Capture Ratio

<1.5 dB

FM Distortion

mono: $<0.15\%$ 1 kHz

stereo: $<0.25\%$ 1 kHz

Stereo Separation

>45 dB 1 kHz

Frequency Response

30 Hz — 15 kHz +0 dB

-0.5 dB

Signal-to-Noise Ratio

mono: >70 dB

stereo: >65 dB

Spurious Rejection

>70 dB

AM Section

Tuning Range

510 — 1,605 kHz

Sensitivity IHF

<15 μ V

Selectivity

>45 dB

Signal-to-Noise Ratio

>45 dB

GENERAL

Power Requirement

AC 220 — 230V 50 Hz

Power Consumption

340W

Dimensions (W-H-D)

450 mm (19.6") — 88 mm (3.52") — 355 mm (14.2")

Weight

9.7 kgs (21.3 lbs.)

CYBERNET MODEL CR-80S STEREO AM/FM RECEIVER WITH DIGITAL FREQUENCY READOUT

UNPACKING

Carefully remove all items from the carton and check for damage. Before discarding any of the packing materials examine them carefully for items you may have overlooked. It will be to your advantage to save original carton, fillers, cushioning, etc. They will prove valuable in preventing damage should you ever have to transport or ship your receiver. Accessories contained originally in carton are:

- Instruction manual
- Cybernet warranty card
- Cybernet decal
- Convenience FM antenna, etc.

INSTALLATION

Installation of the receiver is not complicated, however, the following guidelines must be followed for satisfactory performance and to assure long, reliable service life:

- Do not attempt to remove the cabinet cover, as there are no user serviceable parts inside. Refer servicing only to qualified personnel
- Make sure that the Power switch is in released position before making any installation or connections
- Though the unit is designed to allow a turntable be placed upon it, care must be taken to ventilation not to be restricted. Provide opening as wide as possible, in and out of the cabinet to the room as well.

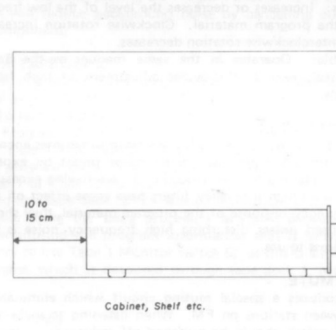

CONNECTIONS

Refer to the Quick Connection and Connector Device diagrams.

Loudspeakers: Connect left and right channel main speakers to receiver terminals A Speakers, using suitable gauge wires. For wire lengths of less than 6 meters, 2 x 0.75 mm² wire is recommended. For longer distances, 2 x 1.5 mm² should be used. This is necessary to avoid power loss and to maintain good control or damping of the loudspeaker. Be ware not to shortcircuit speaker cables, and to phase properly. That is, connect the positive or plus terminal on each speaker to the corresponding plus terminal on the receiver. The minus terminals are likewise connected together. This insures that the speakers are working together and not against each other, providing optimum imaging and best bass response. Take care to connect left and right speakers to the proper channel. In the same

manner, a second pair of speakers may be connected to the Speakers B terminals.

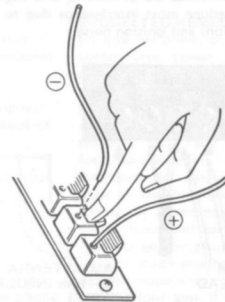

Turntable: Use the cables provided with the turntable or obtain insulated and shielded audio cables terminated with standard pin plug. Make proper channel connection to Phono input jacks. Connect separate ground lead to receiver ground (GND) terminal. Connect turntable power plug into wall outlet.

Auxiliary Equipment: Use insulated and shielded audio cables, terminated with standard pin plug. Connect to Aux input jacks, making proper channel connection. Connect the accessory unit's power plug into wall outlet.

Tape decks: The receiver has been equipped with two pairs of inputs and outputs for connection of any type of tape decks, Tape 1 Rec/Play jacks and Tape 2 Rec/Play jacks, in addition to Tape 2 DIN jack. Connect the output of main tape deck to Tape 1 Play jacks and tape deck's input to Tape 1 Rec jacks. Use insulated and shielded cables. Connect deck's power plug into wall outlet. A second tape deck is connected likewise to Tape 2 jacks. Make connections using cables as above.

Receiver Power Supply: Plug the cord set at the end of the power cord into the wall outlet. Refer to rear panel for specified voltage (220 — 230V) before making any connections.

ANTENNAS

AM FERRITE LOOPSTICK ANTENNA AND EXTERNAL ANTENNA

For optimum AM performance, the loopstick antenna provided on the rear of unit should be positioned for maximum signal strength when the unit is tuned to the desired station. Use Signal strength LED indicator for reference. The associated connecting cables and AC power cord should be dressed as far away as possible. The ferrite loopstick antenna is designed to assure adequate reception of all local AM station, however, in the fringe areas, high noise areas, or where surrounding metal objects interfere with normal reception, external long wire antenna can be connected to the AM antenna terminal. A simple long wire antenna can consist of a length of single conductor of 9 meters or longer, extending from the receiver terminal to the outside of the building.

FM ANTENNA

In strong signal area, an FM dipole antenna supplied with the receiver should be more than adequate for reception of most FM stations. Antenna connections are made to the terminal strip marked FM, located on the rear panel. The dipole should be unfolded to its full T size and oriented for optimum performance because the dipole antennas are most sensitive when positioned perpendicular to the station. If the supplied dipole is not sufficient for satisfactory reception of FM stereo stations, or for reception in fringe (weak signal) areas where interference to FM reception is high, the use of Log-periodic or Yagi antenna system is recommended. These antennas are directional and high gain in nature, thus tending to reduce most interference due to reflected signals (multipath distortion) and ignition noise.

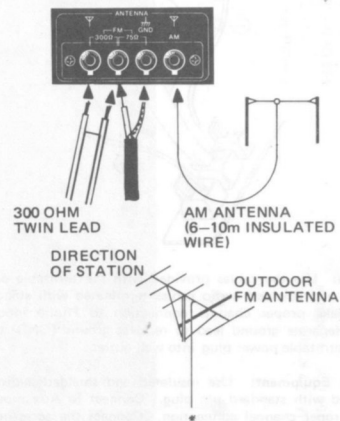

CONTROLS

- POWER ON/OFF**
This switch turns the power on (depressed) or off (released).
- SPEAKER SWITCHES A/B**
These permit you to select one of 4 listening conditions.
A: When depressed, connects the sound output to the speakers attached to the Speakers A output terminals on rear panel.
B: When depressed, connects the sound output to the speakers attached to the Speakers B output terminals located next to the Speakers A output terminals.
Depressing both switches in position connects the sound output simultaneously to the speakers attached to the Speakers A and Speakers B output terminals, and if both switches are released, all speakers are silenced and the sound output is connected only to the headphones plugged into the Phones jack located to the right side of the cabinet. Since the signal is always fed to this jack regardless of the switch selection, it is recommended that the headphones be disconnected when not in use to avoid possible overload.
- DIGITAL FREQUENCY READOUT AND INDICATORS**
In this recessed display panel, four indicators are built in.
Frequency Readout: This indicator gives a direct readout of frequency which the receiver is tuned in, by means of LED.
Signal Strength Indicator: Used for tuning on AM, and also shows relative signal strength on both AM and FM. As the incoming signal level increases, the indicator advances from left to right.
Center Tuning Indicator: Used for precise tuning to the

center of an FM station to assure the optimum FM reproduction. Adjust the Tuning Control 5) for simultaneous lighting of both LEDs vis-à-vis.

- SOURCE SELECTOR**
Selects the program source to be reproduced through the receiver, provided that the Tape Monitor switches 1/2 are set to the Source (released) position.
Phono: Selects the output of stereo turntable connected to the Phono input jacks on rear panel.
FM: Selects automatic FM stereo reception.
Hi-Blend: Activates a circuit which reduces high frequency noise in weak FM stereo reception. This filter does not affect the frequency response but reduces slightly the high frequency stereo separation.
AM: Selects AM reception.
Aux: Selects the program source connected to the Aux input jacks.
- TUNING CONTROL**
Used to tune across the AM or FM band. See Digital Frequency Readout 3).
- TAPE MONITOR SWITCHES 1/2**
Select outputs from tape decks connected to Tape Play 1 or Tape Play 2 input jacks. Program source selected originally by the Source Selector 4) cannot be heard through speakers unless these switches are placed in released position (Source). When these two switches are depressed in positions simultaneously, tape copying from deck 1 to deck 2 is possible. See Tape Deck Operation.
- STONE CONTROLS TREBLE/BASS**
Allow you to adjust the tonal balance of the sound output.
Bass: Increases or decreases the level of the low frequencies in the program material. Clockwise rotation increases and counterclockwise rotation decreases.
Treble: Operates in the same manner as the Bass tone control, except it provides adjustment of high frequency levels.
- HIGH FILTER**
Used to remove high frequency noise sometimes encountered in program materials. Such noise might be experienced when playing a worn record or a tape having excessive hiss. Since all high frequency filters have some effect on the high frequency response of the program material, they should not be used unless disturbing high frequency noise is present. Depress to use.
- FM MUTE**
Introduces a special muting circuit which eliminates noise between stations on FM. When listening to weak stations, this switch should be switched off (released) to prevent the receiver from switching to a mute condition due to reduced signal strength.
- MODE SWITCH/STEREO-MONO**
Determines the manner in which program material will be reproduced through the left and right channels.
Stereo (released): Provides stereophonic reproduction of any stereo program source. This position also provides automatic FM stereo reception.
Mono (depressed): A program source connected to the left and right channel input jacks is mixed and reproduced through both channels.
- LOUDNESS SWITCH**
When released to On position, compensates for deficiencies in human hearing ability at low listening levels based on the Fletcher-Munson curves, this means audio levels of high and low frequencies are boosted.
- VOLUME/BALANCE CONTROLS**
These controls are located concentrically: the small knob is the Volume, and the large knob nearer to the panel is the

Balance control.

Volume: Permits adjustment of the volume for both left and right channels simultaneously.

Balance: Provides left to right channel balance of the program material. Normally this control should be set to its center (12 o'clock) position.

OPERATION

With receiver installed and connected as outlined, proceed as follows:

AM RECEPTION

Rotate the Source Selector 4) to AM position. Rotate the Tuning Control 5) to select desired station. A properly tuned AM station is indicated by maximum Signal Strength indicator 3) reading. Adjust loopstick antenna for maximum signal. During AM reception, FM Mute switch 9), Mode switch 10), and FM Center Tuning indicator 3) are inoperative.

FM RECEPTION

Rotate the Program Selector 4) to FM position. Rotate the Tuning control 5) to select desired FM station. The receiver will automatically switch from monaural to stereo FM operation when tuned to an FM stereo broadcast provided that the Mode switch 10) is set to Stereo (released) position. Stereo broadcasts are indicated by the illuminated Stereo indicator in the display area 3). When listening to weak stations, placing the Program selector 4) in the Hi-Blend position will reduce background noise by cancelling out of phase noise component.

USING A TAPE DECK

To listen to a prerecorded tape, simply select the appropriate Tape monitor switch to depress and play the tape on the desired tape deck. To record a stereo program, select the desired program source on the Program selector 4). This will produce a recording signal at both Tape 1 and Tape 2 Rec output jacks. If you wish to monitor the program information that is being recorded, depress either the Tape 1 or Tape 2 Monitor switch 6). In addition to the recording using one tape deck, simultaneous recording for two tape decks is possible using the same procedure as stated above. However, when monitoring the program information that is being recorded, do not try to use Tape 1 Monitor switch 6), as this channels the program signal which is detoured through tape deck 1, into the tape deck 2.

TAPE COPYING

In order to duplicate a tape from tape deck 1 onto tape deck 2, perform the following. Make sure the inputs and outputs of both tape decks are connected to the Tape 1 and Tape 2 Rec and Play jacks respectively. Depress both the Tape 1 and Tape 2 Monitor switches 6) simultaneously. Play the tape on tape deck 1 and record it on tape deck 2.

HEADPHONES

The receiver is provided with a standardized 6.35 mm phone jack for a stereo headphone plug. You can connect every low impedance (4 to 16 Ohm) or mid-impedance (200 to 2,000 Ohm) headphone. To disconnect all the speakers connected to the receiver, simply

release both the Speakers A and Speakers B switches 2) at the same time.

TROUBLE SHOOTING GUIDE

The following guide is intended as an aid in correcting problems encountered when setting up the stereo system. Although the suggested remedy might seem quite elementary, it may be sufficient to make corrections without returning the receiver to your dealer.

PROBLEM	SUGGESTED REMEDY
Receiver inoperative when power is switched on.	Be sure the power cord is properly connected into power outlet having the same voltage as specified on receiver rear panel.
Indicators light up but no output any mode of operation.	Check the speaker cables for loose or shorted connection. Check the speaker switches and Tape Monitor switches for proper selection.
No output one channel.	Exchange the speaker cables to determine if the problem is in speaker or cables. If phono mode only, check the phono leads and cartridge connections. Interchange the phono cables to input jacks to check whether the same channel remains inoperative.
Scratchy or noisy phono sound.	Lift the tone arm, if the noise stops, the problem probably originates in the cartridge or associated wiring. Connect the ground wire between turntable mechanism and receiver ground terminal.
Hum, phono mode only.	Be sure the phono cable plugs are fully inserted in the receiver input jacks. Move the phono cables around, while listening, to reveal an intermittent or broken shielded cable.
Hum, other inputs.	Check the cables and connections, reverse power plug.
Weak AM reception.	Position AM loopstick antenna for maximum station pickup. Locate the receiver away from metal structures. If building construction uses aluminum foil faced insulation, metal lath, or steel framing, AM reception will be poor. Install an external long wire antenna (see section Antennas).
Weak FM reception.	Check all external antenna connection. Install a properly designed antenna (see Section Antennas). Position the receiving antenna for maximum signal.
FM multipath distortion.	Caused by a broadcast signal reaching the FM receiving antenna from two directions: #1 direct from transmitter to receiver, #2 the same signal but received as a reflection from a nearby building or other surface. Position receiving antenna for minimum distortion (usually maximum signal).
Noisy FM reception.	Install the external antenna. Use shielded lead-in wire. Install proper earth ground. Rotate the antenna for maximum signal. Connect a power line noise filter to interfering appliances.

CONNECTION DEVICE DIAGRAM

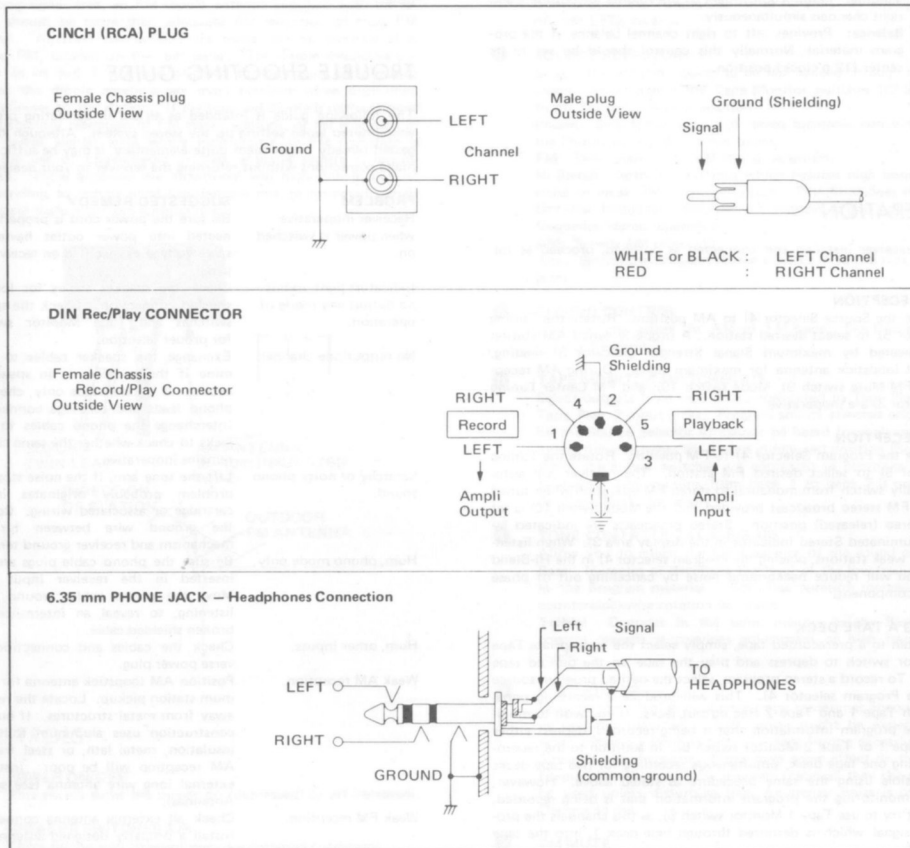

CIRCUIT DESCRIPTION

FM Tuner Circuit

FM signals induced on a FM antenna are led to the FM RF amplifier Q1 through a high Q bandpass filter (T1 & CV1) to select a desired signal. Thus selected and amplified signal is then applied to the base of the mixer (Q2) through another bandpass filter (T2 & CV2) and a coupling capacitor C5, and mixed with the injection signal supplied from the FM local oscillator (Q3) to heterodyne for generating 10.7 MHz intermediate frequency. The 10.7 MHz IF frequency is led to the IF transformer T4 and ceramic filter CF1, then led to the base of IF amplifier Q5. The amplified output is again led to the ceramic filters CF2 and CF3 to achieve high selectivity. Thus selected output is finally led to the limiter/Detector IC4. T5 and T6 are FM discriminator transformers. The detected audio output signal is obtained at pin 6 of IC1, and is led to the FM MPX stereo decoding IC (pin 2 of IC2). The decoded left and right channel signals are obtained at pin 4 and 5, and led to the low pass filter LP1 and LP2 to reduce undesirable 19 kHz, 38 kHz and 67 kHz signals. Thus produced audio outputs are finally led to the selector switch through the resistor R69 and R70, respectively.

FM signal meter output is obtained at pin 13 of IC1 and is applied to the pin 3 of IC4 (LED Meter Drive IC) through the voltage adjusting resistor RV1 to turn on the proper LEDs corresponding to the signal strength being received.

FM muting circuit drive voltage is obtained at pin 12 of IC1 and is applied to the pin 5 of IC1. Since the base bias of the Muting Level Control Transistor Q6 is obtained from the pin 13 of IC1 which supplies increased DC voltage with increased signal strength received, the muting starting level can be varied by adjusting the RV4 which controls the base bias of Q6. The muting switch is connected to the Q6 collector in parallel.

LED Center Meter

The LED center meter consists of two stages of differential amplifiers (Q10/Q11 and Q13/Q14) to control the two LEDs to indicate the receiver is tuned in the center of a channel.

Plus or minus signal produced when the receiver is in out of tuning (depending upon a position of dial pointer) is led to each base of Q10 and Q11, respectively. And the amplifier outputs are led to each base of Q13 and Q14 to drive the LEDs, respectively.

AM Tuner Circuit

The AM tuner circuit is completely integrated and consists of one IC and associated parts.

The pin 2 of IC3 is the input terminal for AM receive signals. T7 is the oscillator coil which determines receive frequency range, and T8 and CF4 are 455 kHz IF filters. The IC3 operates as a convertor IF amplifiers and detector. The detected audio output is obtained at pin 12, and split into two: one is led to the audio amplifier Q8

through C96 and the amplified output is led to the selector switch; another audio output is led to the base of meter driver buffer amplifier Q9 and its output is rectified by D11 to obtain DC voltage. The DC voltage is then supplied to the pin 3 of IC4 (LED Meter Driver IC) through RV3.

Transistor Q7 is an AM switching noise canceller which makes AM output circuit short-circuit to the ground during switching operation.

FM/AM Frequency Indicator Circuit

To indicate receive frequency in numerical figures, AM and FM local oscillator frequencies are utilized as reference signals.

The FM local oscillator signal is first led to the buffer amplifier Q4 through a coupling capacitor C18 and its output is led to the prescaler (IC2) on the PC board PSA2032COX, and its counted down output is applied to the counter (IC1) to count the frequency in term of receive frequency by subtracting 10.7 MHz IF frequency, thus indicating the receive frequency on the LED indicator.

In case of AM reception, the local oscillator frequency is led to the base of buffer amplifier Q45 and its output is directly led to the counter IC. Then the input signal is processed to indicate the frequency in term of receive frequency by subtracting 455 kHz IF frequency.

PHONO Amplifier

This amplifier consists of three transistors Q15, Q17 and Q19 for left channel and Q16, Q18 and Q20 for right channel. No special circuit is used. Their outputs are also connected to the input selector.

Power Amplifier Circuit

Each radio signal supplied to the selector switch is fed to the power amplifier and amplified to the signal level sufficient to drive the speaker loads. RV5 and RV6 are trimming resistors to adjust idling current for reduction of crossover distortion. Transistor Q41 is the speaker relay switch driver circuit which delays emission of sound from the speaker systems, thus eliminating undesirable sounds and protecting the speaker systems against adverse transient operation.

Power Supply Circuit

This receiver is equipped with four AVRs (automatic voltage regulator) Q42 is the AVR for AM and FM circuits. Q43 is the AVR supplying positive voltage to the FM Center Tuning LED Drive Amplifier, LED Meter IC and Phono amplifier. Q44 is the AVR supplying negative voltage to the Phono amplifier and Q7. Q41 is the AVR for LED frequency indicator counter.

TEST EQUIPMENT

Test equipment should be calibrated properly.

To proceed the adjustments for the receiver, following test equipment may be required.

- 1) FM Signal Generator: 30 – 200 MHz, 0 – 106 dB or higher
- 2) FM MPX Generator
- 3) AM Signal Generator: 150 kHz – 30 MHz, 0 – 120 dB
- 4) Audio Signal Generator: 20 Hz – 200 kHz, 0.5mV – 1V
- 5) Audio Level Meter: 0.5mV – 10V or higher, 20 kHz or higher
- 6) Audio Analyzer: 20 Hz – 20 kHz

- 7) Oscilloscope: 1mV/cm, 100 kHz or higher
- 8) Frequency Counter: 20 – 100 kHz, high impedance type
- 9) Sweep Generator: 455 kHz \pm 150 kHz, & 10.7 MHz \pm 1 MHz
- 10) Circuit Tester (Multimeter): High impedance type (20 k ohm/V)
- 11) FM Dummy Antenna
- 12) Dummy Load: 8 ohms, 50W x 2
- 13) Standard Test Loop for AM Signal Radiation
- 14) Power Supply (Variable Voltage)

ALIGNMENT PROCEDURES

Standard Settings for Controls and Switches

Unless otherwise specified, place the controls and switches in position stated below:

- Tone Controls (Bass & Treble): Center Position
- Balance Control: Center position
- Volume Control: Minimum position during FM/AM tuner alignment.
Maximum position during Main amplifier alignment.
Minimum position for all other cases.
- Stereo/Mono: Stereo position
- Loudness: OFF position
- Hi-Filter: OFF position
- FM Mute: OFF position
- Speaker Mode: A position

MAIN AMPLIFIER ALIGNMENT

Idle current alignment

- With no signal applied to the power amplifier, turn the power on, and measure idling current of the final power transistors (Q37/39 & Q38/40).
- Connect a DC voltmeter across the R219 (or R221) and measure the voltage, it should be 19mV. If not, adjust RV5 to obtain the specified reading.
- Connect the DC voltmeter across the R220 (R222) and measure the voltage. If the voltage reading is not 19mV, adjust RV6 for 19mV reading.

AM TUNER ALIGNMENT

A. AM IF Alignment

- Place the selector switch in AM position.
- Connect input lead of IF sweep generator to Pin 12 of IC3 or Tape Rec Jack.
- Connect the sweep generator output to AM antenna terminal.
- When the sweep generator input circuit is connected to the Tape Rec Jack, scope display as shown in Fig. 1 (a-c) may be obtained. Adjust T9 to obtain symmetrical and more straightness of the crossed line (b).
- When the sweep generator is connected to the pin 12 of IC3,

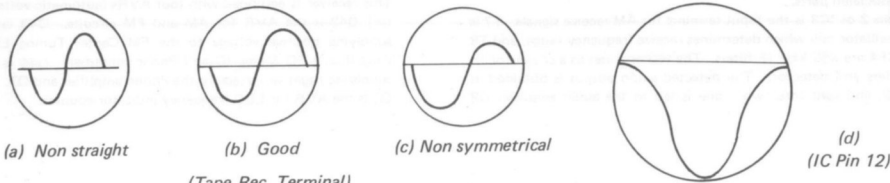

(Tape Rec. Terminal)

Fig. 1 AM IF Response

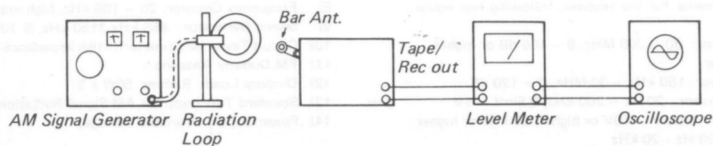

Fig. 2 AM Tuner Alignment Setup

a scopdisplay as shown in Fig. 1 (d) will be obtained. Adjust T9 for highest, widest, symmetrical and round top wave form.

- Note:
- Since ceramic filters are employed, there is no need to match the IF center to 455kHz marker center.
 - Properly adjust the sweep generator output level not to give signal overload to the IF amplifier.

B. Sensitivity and Dial Scale Adjustment

- Connect a calibrated (-26 dB) test loop antenna to the AM signal generator.
- Place the AM bar antenna in its correct position by pulling it outward.
- Place the test loop antenna in such a way that the distance between the center of the test loop antenna and AM bar antenna is 60 cm to obtain calibrated field strength (= SG output -26 dB (uV/m)).
- Connect the test equipment to the receiver as shown in Fig. 2 "AM Tuner Alignment Setup".
- Adjust signal generator to provide 600 kHz, 1000 Hz 30% modulation. Place the dial pointer on 600 kHz scale point on the dial.
- Adjust signal generator output to provide about SN 20 dB audio signal output at the Tape Rec Jacks.
- Adjust oscillator coil T7 core and screw core of the bar antenna to obtain the maximum audio outputs.
- Set the signal generator frequency to 1400 kHz and place the dial pointer to 1400 kHz on the dial scale.
- Adjust AM oscillator trimmer CT4 and antenna trimmer CT5 to obtain the maximum audio outputs.
- Repeat the steps 5 through 9 until no further improvements is obtained.

Note: During above alignment, do not use AM antenna terminal for supplying test signal to avoid inaccurate alignment.

C. LED METER ADJUSTMENT

Increase signal generator output to 100 dB, and adjust RV3 until fifth LED meter element lights up.

FM TUNER ALIGNMENT

Place the selector switch in the FM position.

A. Phase Shift Circuit Alignment

With the receiver applied no signal, adjust T5 core to obtain zero volt reading on a circuit tester connected across the resistor R40 (6.8k ohms).

B. FM IF Alignment

- Couple output of the sweep generator to the RF transformer T2, using a coupling coil (two or three turns of vinyl wire) as shown in Fig. 3.
- Connect pin 13 of IC1 to the sweep generator input terminal, using a coaxial cable. Connect the ground lead of the coaxial cable to the closest point of the IC's ground point. The coaxial cable length should be as short as possible.
- Temporarily short-circuit the oscillator variable capacitor CV3 to stop the oscillation, using a 0.01μF ceramic capacitor.

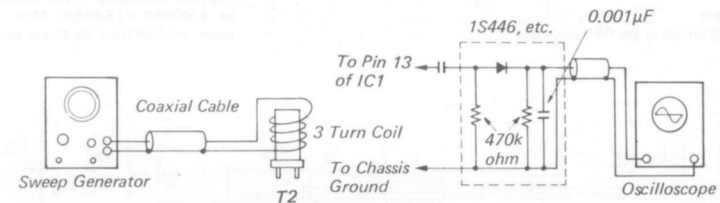

Fig. 3 FM IF Alignment Setup

C. FM Sensitivity and Dial Scale Alignment

- Depress the FM button and place the FM MUTE button in the OFF position.
- Connect the test equipment to the tuner as shown in Fig. 5.
- Adjust the FM signal generator to 90 MHz, 1000 Hz 100% modulation, and place the dial pointer on 90 MHz point of the scale.
- Adjust T1, T2 and T3 cores for maximum audio output.
- Adjust the FM signal generator to 106 MHz and place the dial pointer on 106 MHz point of the dial scale.
- Adjust CT1, CT2 and CT3 for maximum audio output.
- Repeat the above steps 3 through 6 until no further improvement is obtained.

Note: During above alignment keep the signal generator output as low as possible to avoid inaccurate adjustment due to limiter action.

- Finally check usable sensitivity, it should be about 1.8 - 2μV.

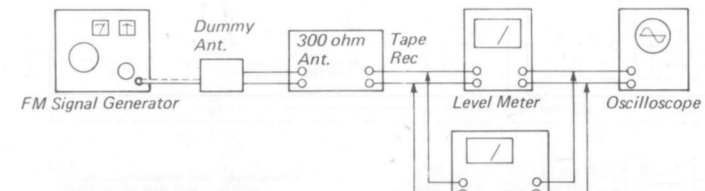

Fig. 5 FM Tuner Test Setup

Distortion Analyzer (Used in IF Distortion)

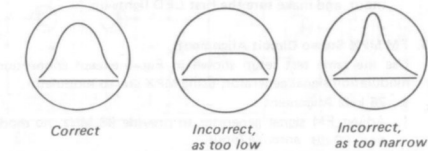

Fig. 4 FM IF Response

D. FM Distortion and Center Tuning LED Alignment

- Adjust signal generator to provide 98 MHz and 22 dB ±3 dB antenna signal input, and tune the receiver to the same frequency.
- Make sure two center tuning LEDs light up. (center tuning)
- Increase the generator output to 66 dB and measure distortion in audio output.
- Adjust T6 for minimum distortion.
- Adjusting the T6 may turn off one of the center tuning LEDs, if this is occurred, repeat the steps (1) through (4) until minimum distortion is obtained with the two LEDs being lit up.

F. Muting Level Adjustment

- Adjust signal generator to provide 22 dB antenna input at 98 MHz. Tune the receiver to the same frequency.
- Adjust RV4 so that audio output just appears on the scope display.

E. Signal Meter Adjustment

1. Adjust signal generator output to 60 dB antenna input, and tune the receiver to the same frequency, making sure two center tuning LEDs are lighting up.
2. Adjust RV1 so that all five LEDs are lit up.
3. Next reduce signal generator output to 20 dB ± 3 dB antenna input, and make sure the first LED lights up.

G. FM MPX Stereo Circuit Alignment

Use the same test setup shown in Fig. 5 except connection of modulation signal generator, using MPX stereo modulator.

- a. 76 kHz Alignment
1. Adjust FM signal generator to provide 98 MHz, no modulation, 60 dB antenna input.
 2. Tune the receiver to the same frequency, using center tuning LED indicator.
 3. Connect a frequency counter to the test point (TP on schematic diagram) and adjust RV2 to obtain 76 kHz ± 200 Hz on the frequency counter

b. Separation Alignment

1. Place the FM MUTE switch in the OFF position.

2. Modulate the FM signal generator with 1 kHz left channel stereo signal and measure the left and right channel audio output. Adjust RV7 so that the minimum right channel output is obtained.
3. Modulate the FM signal generator with 1 kHz right channel stereo signal and make sure the left channel output is about the same level as that of right channel in step 2 above. If excessive difference is observed, readjust RV7 for equal and minimum outputs.

H. Frequency Indicator Circuit Alignment

1. Connect frequency counter probe (14 pF = input capacitance) to No. 36 pin of IC1 on PC board PSAZ032COX, and read the frequency. It should be within 6.553450 and 6.553550MHz. If not, adjust trimming capacitor (40pF).

Note: The frequency reading on the counter depends upon the input capacitance of the counter probe. Using a probe having different input capacitance may give different reading of the frequency. Anyway, the oscillator frequency in the indicator circuit should be 6.553550 - 6.55650 MHz with the counter probe removed from the IC pin terminal.

SCHEMATIC DIAGRAM

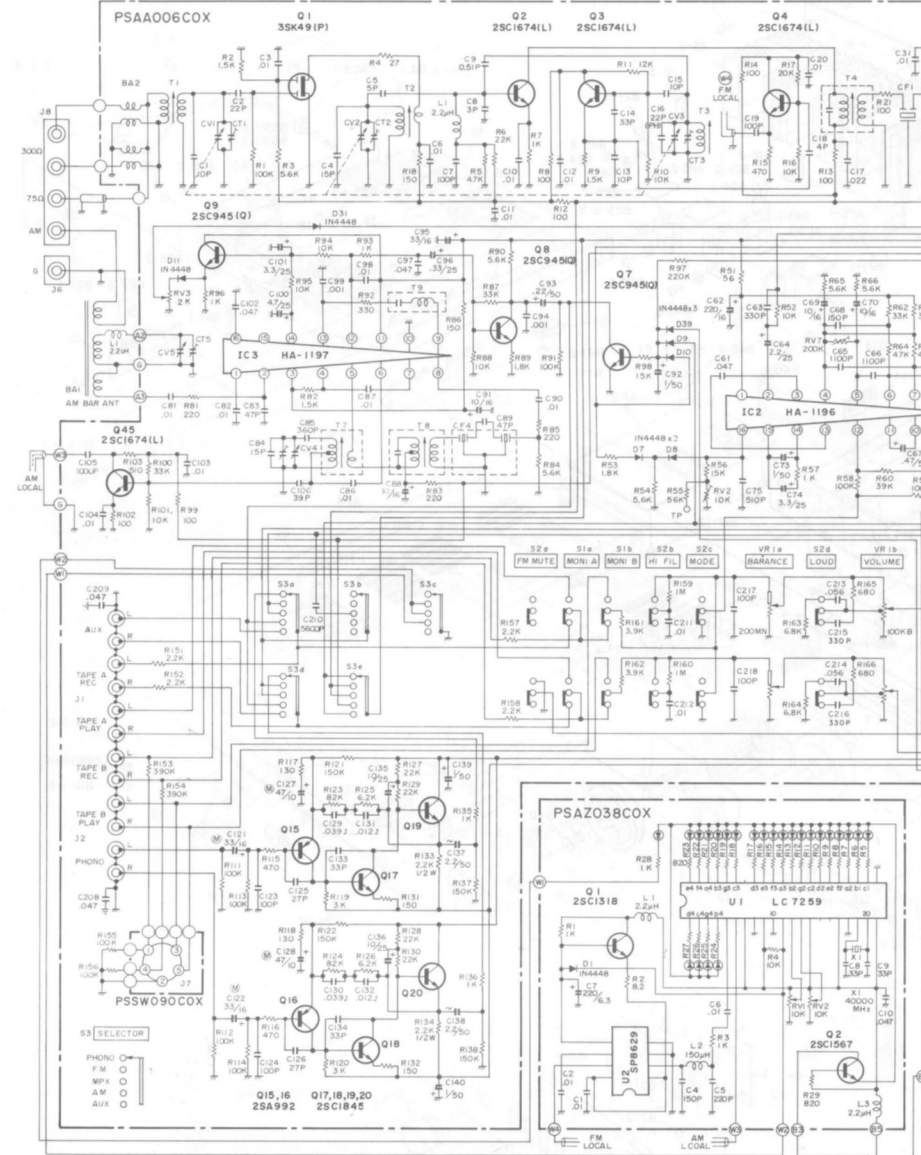

NOTE:
 1. ALL VOLTAGES MEASURED FROM COMMON NEGATIVE CHASSIS GROUND WITH VTVM AT NO SIGNAL.
 2. CAPACITORS VALUES ARE IN μ F UNLESS OTHERWISE NOTED P=PICO/FARAD
 3. RESISTORS VALUES ARE IN OHM K=K OHM
 4. VOLTAGES IN () WHEN MUTE ON
 5. VOLTAGES IN () WHEN AM

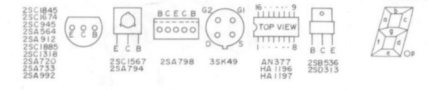

SCHEMATIC DIAGRAM

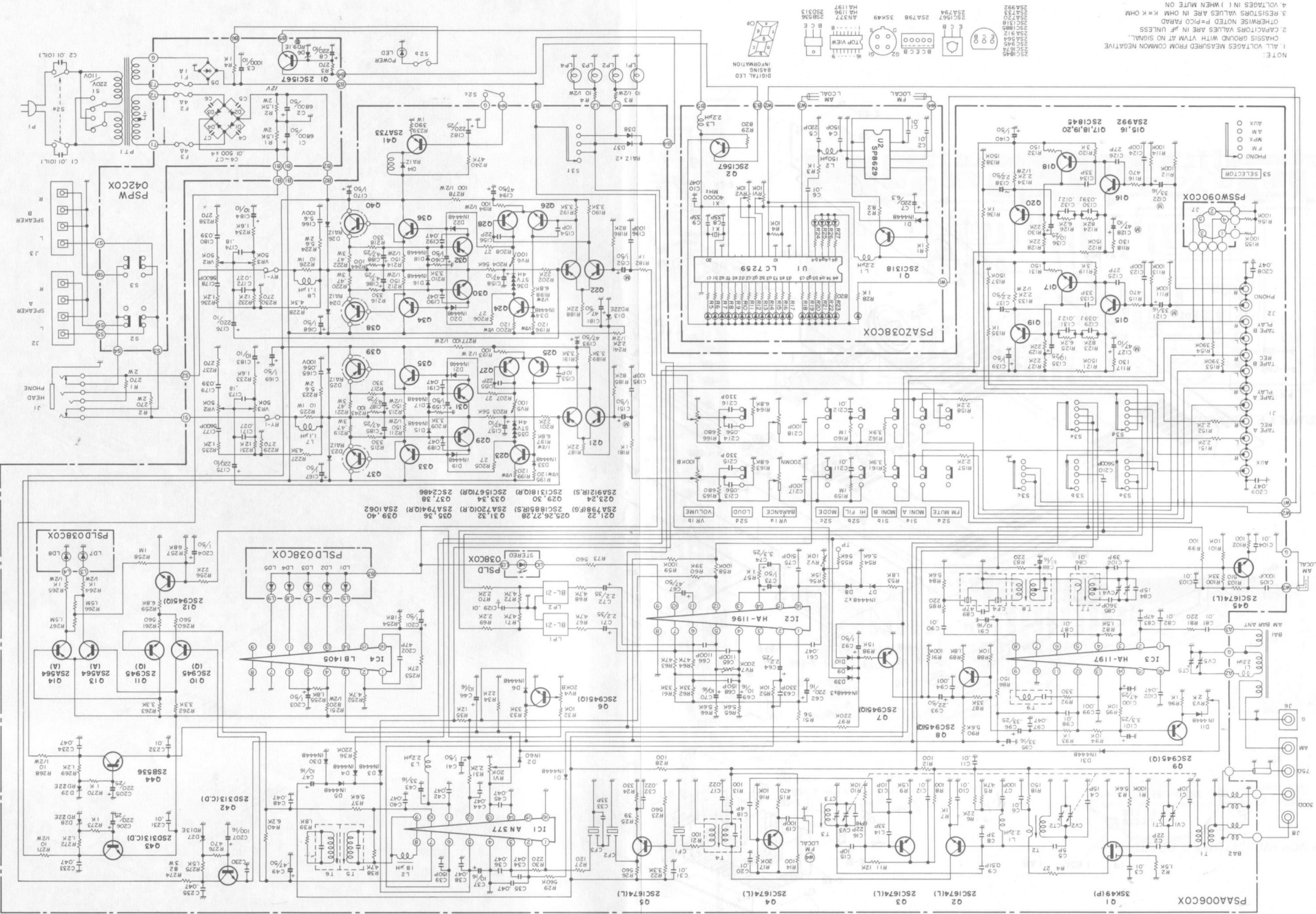

NOTE:
 1. ALL VOLTAGES MEASURED FROM COMMON NEGATIVE
 2. CAPACITORS VALUES ARE IN μ F UNLESS
 OTHERWISE NOTED P=POLY CARBON
 3. RESISTOR VALUES ARE IN OHM K=K OHM
 4. VOLTAGES IN () WHEN MUTED ON
 5. VOLTAGES IN () WHEN AM

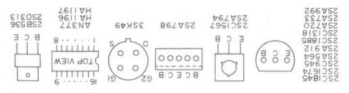

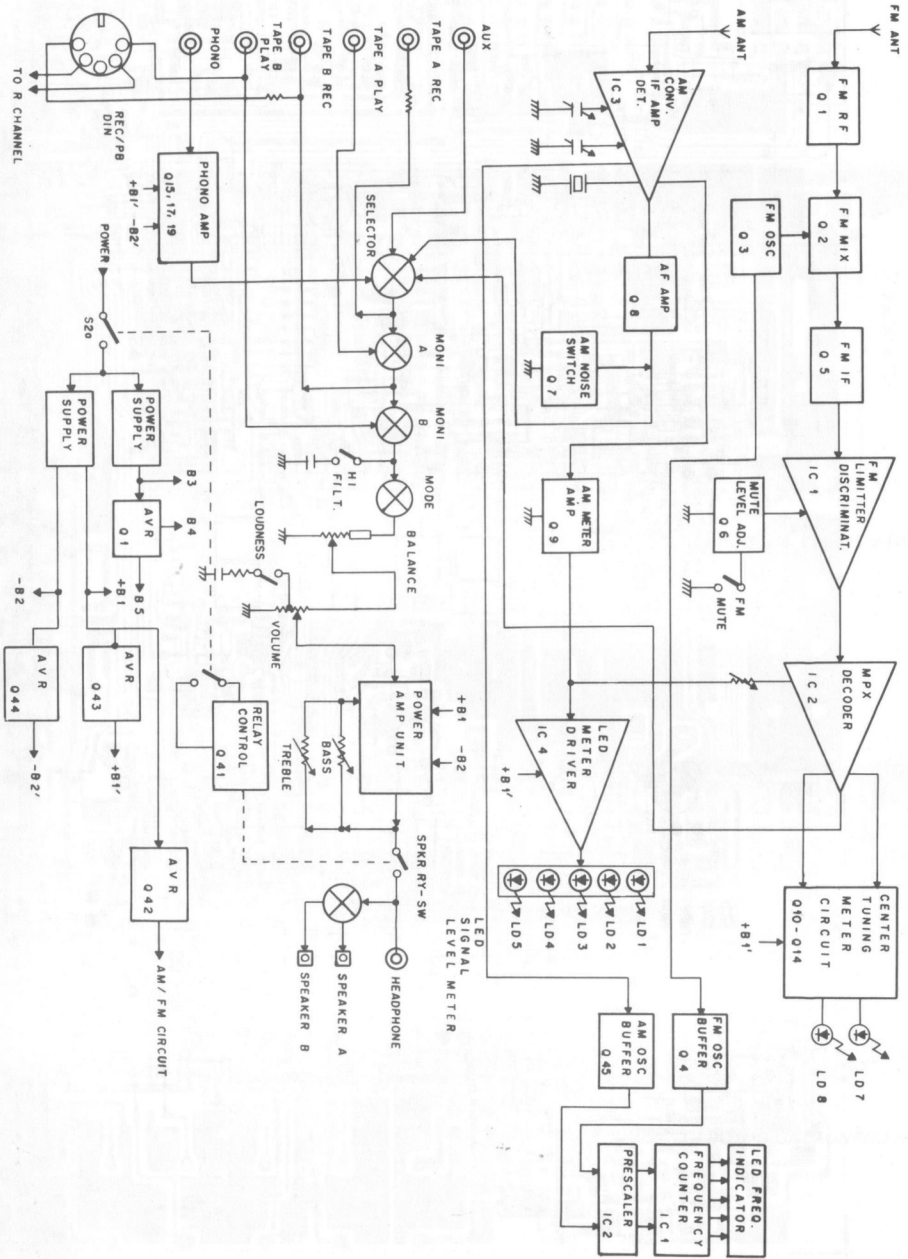

BLOCK DIAGRAM

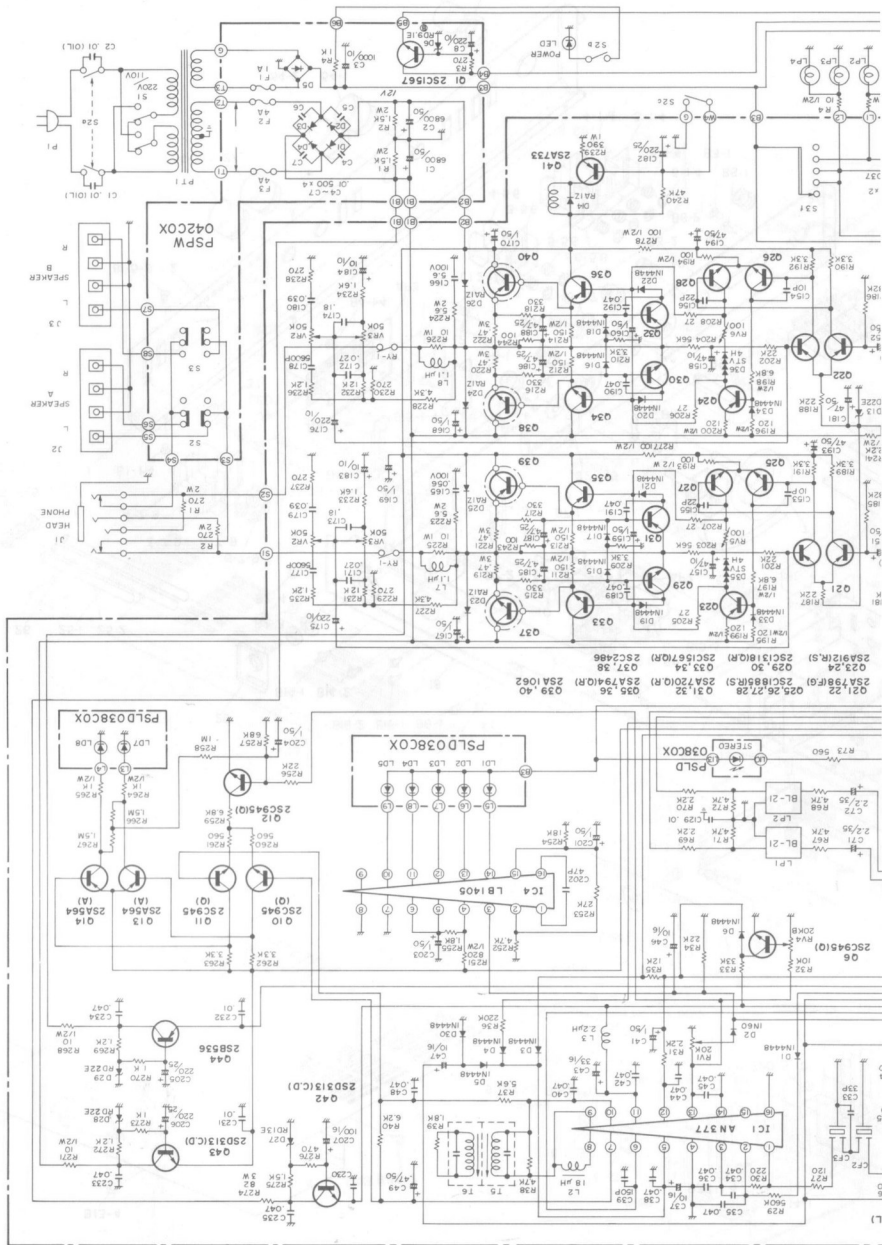

EXPLoded VIEW

EXPLODED ASSEMBLY	PART NAME	PART CODE	STOCK NO.				
REMARKS	MECH. ELEMENTS	PAR5245MCL2					
1/4	PART CODE	PART STOCK NUMBER	PART NAME	SPECIFICATIONS	SYMBOLIC OR EXPLODED VIEW NO.	QTY USED	
1	MF422P001		HOLDER		48		1
2	MH632P001		HOLDER		47		1
3	MH666A001		HEAT SINK		23-1 23-2		2
4	ML1325Z003		BRACKET		12-1 12-2 12-3		3
5	ML331SS001		TERMINAL		44		1
6	ML3425Z009		BRACKET		10		1
7	ML361S2003		BRACKET		11		1
8	ML511S2001		BRACKET		13		1
9	ML752A0002		BRACKET		14-1 14-2		2
10	ML862S2007		SIDE PANEL(L)		18		1
11	ML863S2001		SIDE PANEL(R)		19		1
12	ML875S2001		CHASSIS		20		1
13	MM480P001		HOLDER		46		1
14	MM760A0001		SHAFT		24-1 24-2		2
15	MM760A0002		SHAFT		25-1 25-2		2
16	MM760A0003		SHAFT		26-1		1
17	MN276XA710		KNOB		54		3
18	MN286XA005		KNOB		53		1
19	MN385XA028		KNOB		27		1
20	MS1135P001		LOCK RING		6-1 6-2 6-3 6-4		9
21					6-5 6-6 6-7 6-8		
22					6-9		
23	MT1425N001		PULLEY SHAFT		42-1 42-2		2

EXPLODED ASSEMBLY	PART NAME	PART CODE	STOCK NO.				
REMARKS	CYBERNET	CUSTOMER'S	CYBERNET				
1/4	PART CODE	PART STOCK NUMBER	PART NAME	SPECIFICATIONS	SYMBOLIC OR EXPLODED VIEW NO.	QTY USED	
1	MT162RD22		SPACER		55-1 55-2 55-3 55-4		4
2	MT553RD001		SHAFT		15		1
3	MN261LY002		SPRING		5-1 5-2 5-3 5-4		9
4					5-5 5-6 5-7 5-8		
5					5-9		
6	MN362LY001		SPRING		41		1
7	MX415S2001		CLAMPER		45		1
8	MX966SK001		REAR PANEL		17		1
9	MX982SF001		BOTTOM COVER		21		1
10	MZ422S2004		BRACKET		16-1 16-2		2
11	VF155EM001		BUSHING		43-1 43-2 43-3 43-4		5
12					43-5		
13	VF235S001		SPACER		30		1
14	VK1335A003		HOLDER		29		1
15	VK2325A002		SLEEVE		3-1 3-2 3-3 3-4		9
16					3-5 3-6 3-7 3-8		
17					3-9		
18	VM163DX001		PULLEY		39		1
19	VM183EN001		PULLEY		38		1
20	VM297S0002		PULLEY		40		1
21	VN321S001		KNOB		4-1 4-2 4-3 4-4		9
22					4-5 4-6 4-7 4-8		
23					4-9		

EXPLODED ASSEMBLY	PART NAME	PART CODE	STOCK NO.				
REMARKS	MECH. ELEMENTS	PAR5245MCL2					
1/4	PART CODE	PART STOCK NUMBER	PART NAME	SPECIFICATIONS	SYMBOLIC OR EXPLODED VIEW NO.	QTY USED	
1	V522BRW01		SPACER		37		1
2	V5417NN003		CLAMPER		51		1
3	V5653FR003		SHEET		52		1
4	V5738AG001		FILTER		2		1
5	VVL429GF01		LABEL		34		1
6	VVL531GF05		LABEL		35		1
7	VVL531GF06		LABEL		35		1
8	VVL621U04		LABEL		49		1
9	VVL631U03		LABEL		50-1 50-2		2
10	VV5CR05-1		SER. NO. PLATE		33		1
11	VX3335R001		FOOT		28-1 28-2 28-3 28-4		4
12							
13							
14							
15							
16							
17							
18							
19							
20							
21							
22							
23							

EXPLODED ASSEMBLY	PART NAME	PART CODE	STOCK NO.				
REMARKS	PRINTED MATTERS	PAR5245MCL3					
1/4	PART CODE	PART STOCK NUMBER	PART NAME	SPECIFICATIONS	SYMBOLIC OR EXPLODED VIEW NO.	QTY USED	
1	KC007050XX		WARNING CARD				1
2	KL000072XX		CYB STICKER				1
3	KTCR305*AX		OWNER'S MANUAL				1
4	KW000058XX		WARRANTY CARD				1
5							
6							
7							
8							
9							
10							
11							
12							
13							
14							
15							
16							
17							
18							
19							
20							
21							
22							
23							

EXPLODED ASSEMBLY	PART NAME	PART CODE	STOCK NO.			
REMARKS	PART CODE	PART STOCK NUMBER	PART NAME	SPECIFICATIONS	SYMBOLIC OR EXPLODED VIEW NO.	QTY USED
	PACKING MATTERS	PAB524SMCL1				
1	KF243400E4		POLY BAG			1
2	KF506500E6		POLY BAG			1
3	KL000031XX		LABEL			2
4	KNCR805*01		PARTITIONER			2
5	KPCR805*01		INNER CARTON			1
6	KSCR805*01		OUTER CARTON			1
7						
8						
9						
10						
11						
12						
13						
14						
15						
16						
17						
18						
19						
20						
21						
22						
23						

EXPLODED ASSEMBLY	PART NAME	PART CODE	STOCK NO.			
REMARKS	PART CODE	PART STOCK NUMBER	PART NAME	SPECIFICATIONS	SYMBOLIC OR EXPLODED VIEW NO.	QTY USED
	ACCESSORIES	PAB524SMCL1S				
1	ZAT001502		ANTENNA			
2						
3						
4						
5						
6						
7						
8						
9						
10						
11						
12						
13						
14						
15						
16						
17						
18						
19						
20						
21						
22						
23						

EXPLODED ASSEMBLY	PART NAME	PART CODE	STOCK NO.			
REMARKS	PART CODE	PART STOCK NUMBER	PART NAME	SPECIFICATIONS	SYMBOLIC OR EXPLODED VIEW NO.	QTY USED
	ESCUTCHEON ASSY	AMCR805*01				
1	ME62EA001		ESCUTCHEON		1B-1 1B-2	2
2	ME96EA010		ESCUTCHEON		1A	1
3						
4						
5						
6						
7						
8						
9						
10						
11						
12						
13						
14						
15						
16						
17						
18						
19						
20						
21						
22						
23						

EXPLODED ASSEMBLY	PART NAME	PART CODE	STOCK NO.			
REMARKS	PART CODE	PART STOCK NUMBER	PART NAME	SPECIFICATIONS	SYMBOLIC OR EXPLODED VIEW NO.	QTY USED
	P.W. BOARD ASSY	AP5A0006AD				
1	ASPC3005NZ		CERMS SCREW	(+)BIT, H3 X 5 S-ZNCR		3
2	BTPP3008AZ		PAN TAP SCREW	(+)BIT, H3 X 8 S-ZNCR		1
3	CCDB0300M		CERAMIC CAP.	SL 3PF 50V -0.25, +0.25PF	C8	1
4	CCDB0400CM		CERAMIC CAP.	CH 4PF 50V -0.25, +0.25PF	C18	1
5	CCDB0500DM		CERAMIC CAP.	SL 5PF 50V -0.3, +0.5PF	C5	1
6	CCDB1000EM		CERAMIC CAP.	CH 10PF 50V -0.5, +0.5PF	C13 C15	2
7	CCDB1000DM		CERAMIC CAP.	SL 10PF 50V -0.5, +0.5PF	C1	1
8	CCDB1010EM		CERAMIC CAP.	100PF 50V -10, +10E SL	C19 C7	2
9	CCDB1500DM		CERAMIC CAP.	15PF 50V -10, +10E SL	C4	1
10	CCDB2200EM		CERAMIC CAP.	22PF 50V -10, +10E PH	C16	1
11	CCDB2200DM		CERAMIC CAP.	22PF 50V -10, +10E SL	C2	1
12	CCDB3300EM		CERAMIC CAP.	33PF 50V -10, +10E CH	C14	1
13	CCFB1510DT		CERAMIC CAP.	150PF 50V -10, +10E SL	C39 C68	2
14	CCFA3310DT		CERAMIC CAP.	330PF 50V -10, +10E SL	C215 C216 C63	3
15	CCGB1000DT		CERAMIC CAP.	SL 10PF 50V -0.5, +0.5PF	C193 C194	2
16	CCGB1010DT		CERAMIC CAP.	100PF 50V -10, +10E SL	C123 C124 C195 C196	6
17					C217 C218	
18	CCGB1500PT		CERAMIC CAP.	15PF 50V -10, +10E PH	C84	1
19	CCGB2200DT		CERAMIC CAP.	22PF 50V -10, +10E SL	C195 C196	2
20	CCGB2700DT		CERAMIC CAP.	27PF 50V -10, +10E SL	C125 C126	2
21	CCGB3300DT		CERAMIC CAP.	33PF 50V -10, +10E SL	C33	1
22	CCGB3900DT		CERAMIC CAP.	39PF 50V -10, +10E SL	C106	1
23	CCGB4700DT		CERAMIC CAP.	47PF 50V -10, +10E SL	C202 C83 C89	3

EXPLODED ASSEMBLY	PART NAME		PART CODE	STOCK NO.	REMARKS	PART CODE	PART STOCK NUMBER	PART NAME	SPECIFICATIONS	SYMBOLIC OR EXPLODED VIEW NO.	QTY USED
	P.W.BOARD ASSY	APSA006AD									
1		CFAC221ALX					ELYT. CAPACITOR	220MFD 10V	C175 C176		2
2		CEAD101ALX					ELYT. CAPACITOR	100MFD 16V	C207		1
3		CEAD221ALX					ELYT. CAPACITOR	220MFD 16V	C62		1
4		CEAD4702MN					ELYT. CAPACITOR	47MFD 16V MS	C127 C128		2
5		CEAE221ALX					ELYT. CAPACITOR	220MFD 25V	C182 C205 C206		3
6		CEAE3R32MN					ELYT. CAPACITOR	3.3MFD 25V MS	C121 C122		2
7		CEAE570ALX					ELYT. CAPACITOR	47MFD 25V	C181		1
8		CEAGR227MN					ELYT. CAPACITOR	0.22MFD 50V MS	C93		1
9		CEAGR337MN					ELYT. CAPACITOR	0.33MFD 50V MS	C26		1
10		CEAGR47ALX					ELYT. CAPACITOR	0.47MFD 50V	C49 C67		2
11		CEAG102MN					ELYT. CAPACITOR	1MFD 50V MS	C151 C152		2
12		CEAG2R24LN					ELYT. CAPACITOR		C137 C138		2
13		CEAG470ALX					ELYT. CAPACITOR	47MFD 50V	C193 C194		2
14		CEVC470ALX					ELYT. CAPACITOR		C157 C158		2
15		CEVD100BLX					ELYT. CAPACITOR		C193 C184 C37 C46		9
16									C47 C59 C70 C88		
17									C91		
18		CEVD330BLX					ELYT. CAPACITOR		C43 C95		2
19		CEVE100ALX					ELYT. CAPACITOR		C135 C136		2
20		CEVE2R2ALX					ELYT. CAPACITOR		C64 C71 C72		3
21		CEVE3R3ALX					ELYT. CAPACITOR		C101 C74		2
22		CEVE4R7ALX					ELYT. CAPACITOR		C100 C185 C186 C187		5
23									C188		

EXPLODED ASSEMBLY	PART NAME		PART CODE	STOCK NO.	REMARKS	PART CODE	PART STOCK NUMBER	PART NAME	SPECIFICATIONS	SYMBOLIC OR EXPLODED VIEW NO.	QTY USED
	P.W.BOARD ASSY	APSA006AD									
1		COMB273KE4					MYLAR CAPACITOR	0.027MFD 50V -10, +10%	C171 C172		2
2		COMB393JEH					MYLAR CAPACITOR		C129 C130		2
3		COMB393KEH					MYLAR CAPACITOR	0.039MFD 50V -10, +10%	C179 C180		2
4		COMB562KEH					MYLAR CAPACITOR	5600PF 50V -10, +10%	C177 C178 C210		3
5		COMB563KEH					MYLAR CAPACITOR	0.056MFD 50V -10, +10%	C213 C214		2
6		COMC563KEH					MYLAR CAPACITOR		C165 C166		2
7		CQSC112JCF					STYRIFLEX CAP.	1100PF 100V -5, +5%	C65 C66		2
8		CQSC361JCF					STYRIFLEX CAP.	360PF 100V -5, +5%	C85		1
9		CQSC511JCF					STYRIFLEX CAP	510PF 100V -5, +5%	C75		1
10		CVA2333A02					VARIABLE CAP.		CV1-5		1
11		FBR455A10M					CERAMIC FILTER.		CF4		1
12		FBI087F14M					CERAMIC FILTER		CF1 CF2 CF3		3
13		FJRR38L04C					LOW PASS FILTER		LP1 LP2		2
14		LA3LE1024A					CHOKE COIL		L7 L8		2
15		LCDA3038A					RF COIL		L1 L3		2
16		LF180JCO1K					RF COIL.		L2		1
17		HL64352001					BRACKET				1
18		MU242AD002					HEAT SINK				1
19		MW201R5001					TERMINAL				35
20		MW401CX003					SHORT JUMPER				1
21		MW401CX005					SHORT JUMPER				1
22		MW401CX006					SHORT JUMPER				113
23		MX66455001					SHIELD				1

EXPLODED ASSEMBLY	PART NAME		PART CODE	STOCK NO.	REMARKS	PART CODE	PART STOCK NUMBER	PART NAME	SPECIFICATIONS	SYMBOLIC OR EXPLODED VIEW NO.	QTY USED
	P.W.BOARD ASSY	APSA006AD									
1		CEVG10ALX					ELYT. CAPACITOR		C139 C140 C159 C160		14
2									C167 C168 C169 C170		
3									C201 C203 C204 C41		
4									C73 C92		
5		CG2HR51KPB					MINIC CAPACITOR		C9		1
6		CKOB1037F4					CERAMIC CAP.	0.01MFD 50V -20, +80% F	C10 C11 C12 C20		6
7									C3 C6		
8		CKOB2237F4					CERAMIC CAP.	0.022MFD 50V -20, +80% F	C17		1
9		CKFR1037FT					CERAMIC CAP.	0.01MFD 50V -20, +80% F	C103 C104 C219 C230		13
10									C231 C232 C31 C81		
11									C82 C86 C87 C90		
12									C98		
13		CKFR2237FT					CERAMIC CAP.	0.022MFD 50V -20, +80% F	C32		1
14		CKFR4737FT					CERAMIC CAP.	0.047MFD 50V -20, +80% F	C102 C189 C190 C191		21
15									C192 C200 C221 C233		
16									C234 C235 C24 C35		
17									C35 C38 C40 C42		
18									C44 C45 C48 C61		
19									C97		
20		CKGB102ZFT					CERAMIC CAP.	1000PF 50V -20, +80% F	C105 C94 C99		3
21		COMB103KEH					MYLAR CAPACITOR	0.01MFD 50V -10, +10%	C211 C212		2
22		COMB123JEH					MYLAR CAPACITOR	0.012MFD 50V -5, +5%	C131 C132		2
23		COMB184KEH					MYLAR CAPACITOR	0.18MFD 50V -10, +10%	C173 C174		2

EXPLODED ASSEMBLY	PART NAME		PART CODE	STOCK NO.	REMARKS	PART CODE	PART STOCK NUMBER	PART NAME	SPECIFICATIONS	SYMBOLIC OR EXPLODED VIEW NO.	QTY USED
	P.W.BOARD ASSY	APSA006AD									
1		PSA006COX					P.W.BOARD				1
2		PSCR805CX					PRINTED W.BOARD				1
3		QDG1V60XT					GERMANIUM DIODE	NO-RANK		D2	1
4		QDSN448XZ					SILICON DIODE	1N4448 VSM=100V NO-RANK		D1 D10 D11 D15	23
5										D16 D17 D18 D19	
6										D20 D21 D22 D3	
7										D30 D31 D33 D34	
8										D39 D4 D5 D6	
9										D7 D8 D9	
10		QDSR412X0					SILICON DIODE	PA1Z NO-RANK		D14 D23 D24 D25	7
11										D26 D37 D38	
12		QDZRD13FA					ZENER DIODE	RD13F VZ=13.0-14.2 N2-1AN625M1V		D27	1
13		QDZRD22FDA					ZENER DIODE	RD22FE R41VZ=21.52-22.630-RANK		D13 D28 D29	3
14		QQMAN377AN					I.C.	AN377		IC1	1
15		QQM41196AB					I.C.	M41196 16-PIV FM-MPX		IC2	1
16		QQM41197AB					I.C.	M41197 16-PIV AM-TUNER		IC3	1
17		QQM01405AC					I.C.	L81405 LEVEL-METER		IC4	1
18		QTA0564ACN					TRANSISTOR	2SA564A Q-R-RANK		Q13 Q14	2
19		QTA0720XBN					TRANSISTOR	2SA720 Q-R-RANK		Q21 Q22	2
20		QTA0733XAA					TRANSISTOR	2SA733 Q-RANK		Q41	1
21		QTA0794XAN					TRANSISTOR			Q35 Q36	2
22		QTA0798KEE					TRANSISTOR	2SA798 F.G-RANK BREAK VOLTAGE=70V		Q21 Q22	2
23		QTA0912KAN					TRANSISTOR	2SA912 R.S-RANK		Q23 Q24	2

EXPLODED ASSEMBLY	PART NAME	PART CODE	STOCK NO.				
REMARKS	PART CODE	PART STOCK NUMBER	PART NAME	SPECIFICATIONS	SYMBOLIC OR EXPLODED VIEW NO.	QTY USED	
1	QTA0992KAA		TRANSISTOR		Q15 Q16		5
2	QTB0536KBA		TRANSISTOR	25B536(2) L,M-RANK	Q44		1
3	QTC0945ABA		TRANSISTOR	25C945A Q-RANK	Q10 Q11 Q12 Q6		7
4					Q7 Q8 Q9		
5	QTC1319KDN		TRANSISTOR	25C1319 Q,R-RANK	Q29 Q30		2
6	QTC1567KAN		TRANSISTOR		Q33 Q34		2
7	QTC1674XAA		TRANSISTOR	25C1674 L-RANK	Q2 Q3 Q4 Q45		5
8					Q5		
9	QTC1845KAA		TRANSISTOR	25C1845 E,F-RANK	Q17 Q18 Q19 Q20		4
10	QTC1885KAN		TRANSISTOR	25C1885 R,S-RANK	Q25 Q26 Q27 Q28		4
11	QTD00313KAC		TRANSISTOR	25D313 C,D-RANK	Q42 Q43		2
12	QTL0049KAN		TRANSISTOR		Q1		1
13	QWESTV4HXD		VARIABLE	STV-4H G,H-RANK (WF:2,10V-2,35V)	Q35 Q36		2
14	RD25PJ101X		CARBON FILM R.	0.25W 100 OHM 5%	R102 R12 R13 R14		10
15					R21 R243 R244 R28		
16					R8 R99		
17	RD25PJ102X		CARBON FILM R.	0.25W 1K OHM 5%	R135 R136 R181 R182		11
18					R270 R273 R275 R57		
19					R7 R93 R96		
20	RD25PJ103X		CARBON FILM R.	0.25W 10K OHM 5%	R101 R16 R52 R88		6
21					R94 R95		
22	RD25PJ104X		CARBON FILM R.	0.25W 100K OHM 5%	R1 R111 R112 R113		10
23					R114 R155 R156 R58		

EXPLODED ASSEMBLY	PART NAME	PART CODE	STOCK NO.				
REMARKS	PART CODE	PART STOCK NUMBER	PART NAME	SPECIFICATIONS	SYMBOLIC OR EXPLODED VIEW NO.	QTY USED	
1					R59 R91		
2	RD25PJ105X		CARBON FILM R.	0.25W 1M OHM 5%	R159 R160 R258		3
3	RD25PJ121X		CARBON FILM R.	0.25W 120 OHM 5%	R27		1
4	RD25PJ122X		CARBON FILM R.	0.25W 1.2K OHM 5%	R235 R236 R269 R272		4
5	RD25PJ123X		CARBON FILM R.	0.25W 12K OHM 5%	R231 R232 R35		3
6	RD25PJ131X		CARBON FILM R.	0.25W 130 OHM 5%	R117 R118		2
7	RD25PJ151X		CARBON FILM R.	0.25W 150 OHM 5%	R131 R132 R18 R86		4
8	RD25PJ152X		CARBON FILM R.	0.25W 1.5K OHM 5%	R2 R82 R9		3
9	RD25PJ153X		CARBON FILM R.	0.25W 15K OHM 5%	R54 R98		2
10	RD25PJ154X		CARBON FILM R.	0.25W 150K OHM 5%	R121 R122 R137 R138		4
11	RD25PJ155X		CARBON FILM R.	0.25W 1.5M OHM 5%	R266 R267		2
12	RD25PJ162X		CARBON FILM R.	0.25W 1.6K OHM 5%	R233 R234		2
13	RD25PJ182X		CARBON FILM R.	0.25W 1.8K OHM 5%	R255 R39 R53 R89		4
14	RD25PJ203X		CARBON FILM R.	0.25W 20K OHM 5%	R17		1
15	RD25PJ221X		CARBON FILM R.	0.25W 220 OHM 5%	R30 R81 R83 R85		4
16	RD25PJ222X		CARBON FILM R.	0.25W 2.2K OHM 5%	R151 R152 R157 R158		4
17					R31 R34 R69 R70		
18	RD25PJ223X		CARBON FILM R.	0.25W 22K OHM 5%	R127 R128 R129 R130		10
19					R187 R188 R201 R202		
20					R256 R6		
21	RD25PJ224X		CARBON FILM R.	0.25W 220K OHM 5%	R36 R97		2
22	RD25PJ270X		CARBON FILM R.	0.25W 27 OHM 5%	R205 R206 R207 R208		4
23	RD25PJ271X		CARBON FILM R.	0.25W 270 OHM 5%	R229 R230 R237 R238		4

EXPLODED ASSEMBLY	PART NAME	PART CODE	STOCK NO.				
REMARKS	PART CODE	PART STOCK NUMBER	PART NAME	SPECIFICATIONS	SYMBOLIC OR EXPLODED VIEW NO.	QTY USED	
1	RD25PJ273X		CARBON FILM R.	0.25W 27K OHM 5%	R253		1
2	RD25PJ302X		CARBON FILM R.	0.25W 3K OHM 5%	R119 R120		2
3	RD25PJ331X		CARBON FILM R.	0.25W 330 OHM 5%	R215 R216 R217 R218		6
4					R24 R92		
5	RD25PJ332X		CARBON FILM R.	0.25W 3.3K OHM 5%	R149 R190 R191 R192		10
6					R209 R210 R22 R262		
7					R253 R32		
8	RD25PJ333X		CARBON FILM R.	0.25W 33K OHM 5%	R100 R33 R61 R62		5
9					R87		
10	RD25PJ390X		CARBON FILM R.	0.25W 39 OHM 5%	R25		1
11	RD25PJ392X		CARBON FILM R.	0.25W 3.9K OHM 5%	R161 R162		2
12	RD25PJ393X		CARBON FILM R.	0.25W 39K OHM 5%	R60		1
13	RD25PJ394X		CARBON FILM R.	0.25W 390K OHM 5%	R153 R154		2
14	RD25PJ432X		CARBON FILM R.	0.25W 4.3K OHM 5%	R227 R228		2
15	RD25PJ471X		CARBON FILM R.	0.25W 470 OHM 5%	R115 R116 R276		3
16	RD25PJ472X		CARBON FILM R.	0.25W 4.7K OHM 5%	R38 R5 R67 R68		6
17					R71 R72		
18	RD25PJ473X		CARBON FILM R.	0.25W 47K OHM 5%	R240 R63 R64		3
19	RD25PJ511X		CARBON FILM R.	0.25W 510 OHM 5%	R103		1
20	RD25PJ560X		CARBON FILM R.	0.25W 56 OHM 5%	R51		1
21	RD25PJ561X		CARBON FILM R.	0.25W 560 OHM 5%	R23 R26 R260 R261		4
22	RD25PJ562X		CARBON FILM R.	0.25W 5.6K OHM 5%	R3 R37 R54 R65		7
23					R66 R94 R90		

EXPLODED ASSEMBLY	PART NAME	PART CODE	STOCK NO.				
REMARKS	PART CODE	PART STOCK NUMBER	PART NAME	SPECIFICATIONS	SYMBOLIC OR EXPLODED VIEW NO.	QTY USED	
1	RD25PJ563X		CARBON FILM R.	0.25W 56K OHM 5%	R203 R204 R55		3
2	RD25PJ564X		CARBON FILM R.	0.25W 560K OHM 5%	R29		1
3	RD25PJ622X		CARBON FILM R.	0.25W 5.2K OHM 5%	R125 R126 R40		3
4	RD25PJ681X		CARBON FILM R.	0.25W 680 OHM 5%	R165 R166		2
5	RD25PJ682X		CARBON FILM R.	0.25W 6.8K OHM 5%	R163 R164 R259		3
6	RD25PJ683X		CARBON FILM R.	0.25W 68K OHM 5%	R257		1
7	RD25PJ823X		CARBON FILM R.	0.25W 82K OHM 5%	R123 R124 R185 R186		4
8	RD25TJ183X		CARBON FILM R.	0.25W 18K OHM 5%	R254		1
9	RD25TJ472X		CARBON FILM R.	0.25W 4.7K OHM 5%	R252		1
10	RD25TJ561X		CARBON FILM R.	0.25W 560 OHM 5%	R73		1
11	RD25VJ103X		CARBON FILM R.	0.25W 10K OHM 5%	R10		1
12	RD25VJ123X		CARBON FILM R.	0.25W 12K OHM 5%	R11		1
13	RD25VJ270X		CARBON FILM R.	0.25W 27 OHM 5%	R4		1
14	RD25VJ471X		CARBON FILM R.	0.25W 470 OHM 5%	R15		1
15	RD035KR67B		WIRE WOUND R.	3W 0.47 OHM 10%	R219 R220 R221 R222		4
16	RD035KR20B		WIRE WOUND R.		R274		1
17	RGHANJ101N		M-OXIDE FILM R.	1/2W 100 OHM 5%	R193 R194 R277 R278		4
18	RGHANJ102N		M-OXIDE FILM R.	1/2W 1K OHM 5%	R264 R265		2
19	RGHANJ121N		M-OXIDE FILM R.	1/2W 120 OHM 5%	R195 R196 R199 R200		4
20	RGHANJ151N		M-OXIDE FILM R.	1/2W 150 OHM 5%	R211 R212 R213 R214		4
21	RGHANJ222N		M-OXIDE FILM R.	1/2W 2.2K OHM 5%	R133 R134 R241		3
22	RGHANJ682N		M-OXIDE FILM R.	1/2W 6.8K OHM 5%	R197 R198		2
23	RGHANJ821N		M-OXIDE FILM R.	1/2W 820 OHM 5%	R251		1

EXPLODED ASSEMBLY		PART NAME		PART CODE		STOCK NO.	
REMARKS		P.W.RQARD ASSY		AP5AA006AD			
1/4	REMARKS	PART CODE	PART, STOCK NUMBER	PART NAME	SPECIFICATIONS	SYMBOLIC OR EXPLODED VIEW NO.	QTY USED
1		RG1ANJ391M		M-OXIDE FILM R.	1W 390 OHM 5%	R230	1
2		RPGNB20202		SEMI-FIXED VR.	2K OHM B-CURVE	RV3	1
3		RPGNB20301		SEMI-FIXED VR.	20K OHM B-CURVE	RV1 RV4	2
4		RPGNB20401		SEMI-FIXED VR.	200K OHM B-CURVE	RV7	1
5		RPJNB10101		SEMI-FIXED VR.	100 OHM B-CURVE	RV5 RV6	2
6		PPJNB10302		SEMI-FIXED VR.	10K OHM B-CURVE	RV2	1
7		RV2A503H03		VR.		VR2 VR3	2
8		RVUAI04X01		VR.		VR1	1
9		RXHANJ100N		M-OXIDE FILM R.	1/2W 10 OHM 5%	R268 R271	2
10		RX1ANJ100N		M-OXIDE FILM R.	1W 10 OHM 5%	R225 R226	2
11		RX2ANJ966N		M-OXIDE FILM R.	2W 5.6 OHM 5%	R223 R224	2
12		SH060504UN		SLIDE ROTARY SW		S3	1
13		SP028AX01A		PUSH. SWITCH		S1	1
14		SP048AX01A		PUSH. SWITCH		S2	1
15		TR47JZ0025		RF COIL		T2	1
16		TR47JZ0035		RF COIL		T3	1
17		TR47JZ0075		RF COIL		T1	1
18		TR078H001M		I.F.T.		T9	1
19		TR108N0175		RF COIL		T7	1
20		TR101LA0245		I.F.T.		T8	1
21		TR10MA0035		I.F.T.		T4	1
22		TR10HM0134		I.F.T.		T5	1
23		TR10HM0144		I.F.T.		T6	1

EXPLODED ASSEMBLY		PART NAME		PART CODE		STOCK NO.	
REMARKS		P.W.RQARD ASSY		AP5AA006AD			
1/4	REMARKS	PART CODE	PART, STOCK NUMBER	PART NAME	SPECIFICATIONS	SYMBOLIC OR EXPLODED VIEW NO.	QTY USED
1		TV750301A2		BALANCE COIL		RA2	1
2		WSG120JJJJ		SHIELDED WIRE		NO1	1
3		WSG224JJJJ		SHIELDED WIRE		NO2	1
4		WTH016EEKX		SOLID WIRE		NO3	1
5		WTH111EEKX		SOLID WIRE		NO4	1
6		WTH224EEKX		SOLID WIRE		NO5	1
7		WTH323EEKX		SOLID WIRE		NO6	1
8		Y800312111		BEADS.			10
9		YJP06S009U		6P PIN JACK		J1 J2	2
10		ZRA244102Z		RELAY		K1	1
11							
12							
13							
14							
15							
16							
17							
18							
19							
20							
21							
22							
23							

EXPLODED ASSEMBLY		PART NAME		PART CODE		STOCK NO.	
REMARKS		P.W.RQARD ASSY		AP5AZ038AA			
1/4	REMARKS	PART CODE	PART, STOCK NUMBER	PART NAME	SPECIFICATIONS	SYMBOLIC OR EXPLODED VIEW NO.	QTY USED
1		CCCB151K0M		CERAMIC CAP.	150PF 50V -10, +10% SL	C4	1
2		CCCB221K0M		CERAMIC CAP.	220PF 50V -10, +10% SL	C5	1
3		CCCB330KCM		CERAMIC CAP.	33PF 50V -10, +10% CH	C8 C9	2
4		CEAB221JALX		ELYT. CAPACITOR	220MFD 6.3V	C7	1
5		CKCB1037FM		CERAMIC CAP.	0.01MFD 50V -20, +80% F	C1 C11 C2	4
6		CKCB4737FM		CERAMIC CAP.	0.047MFD 50V -20, +80% F	C10	1
7		LCADA3038A		RF COIL		L1 L3 L4	3
8		LF151KAM1T		R.F.C.		L2	1
9		MR43250D05		SHEILD			1
10		MS43550D02		SHEILD			1
11		MW401CX001		SHORT JUMPER			1
12		PSAZ038FOX		PRINTED W. BOARD			1
13		QDSM4448XZ		SILICON DIODE	1N4448 VRM=100V NO-RANK	D1	1
14		QQT08629AC		I.C.		U2	1
15		QQ007259AC		IC		U1	1
16		QTC1318X0N		TRANSISTOR	2SC1318 Q,R-RANK	Q1	1
17		QTC1567X4N		TRANSISTOR		Q2	1
18		RD25VJ102X		CARBON FILM R.	0.25W 1K OHM 5%	R1 R3	2
19		RD25VJ103X		CARBON FILM R.	0.25W 17K OHM 5%	R4	1
20		RD25VJ561X		CARBON FILM R.	0.25W 560 OHM 5%	R10 R11 R12 R13	24
21						R14 R15 R16 R17	
22						R18 R19 R20 R21	
23						R22 R23 R24 R25	

EXPLODED ASSEMBLY		PART NAME		PART CODE		STOCK NO.	
REMARKS		P.W.RQARD ASSY		AP5AZ038AA			
1/4	REMARKS	PART CODE	PART, STOCK NUMBER	PART NAME	SPECIFICATIONS	SYMBOLIC OR EXPLODED VIEW NO.	QTY USED
1						R26 R27 R29 R5	
2						R6 R7 R8 R9	
3		RD25VJ902X		CARBON FILM R.	0.25W R,2 OHM 5%	R2	1
4		RD25VJ821X		CARBON FILM R.	0.25W 820 OHM 5%	R29	1
5		RPFNB10301		SEMI-FIXED VR.	10K OHM B-CURVE	RV1 RV2	2
6		RXHANJ100N		M-OXIDE FILM R.	1/2W 10 OHM 5%	R30 R31	2
7		WDD344JJJJ		COAXIAL CABLE		NO6	1
8		WDD648JJJJ		COAXIAL CABLE		NO5	1
9		WTG118FEXX		SOLID WIRE		NO1	1
10		WTG209EEXX		SOLID WIRE		NO2	1
11		WTG310FEXX		SOLID WIRE		NO3	1
12		XAZ1930025		XTAL OSCILLATOR		X1	1
13		YZA3000002		6P L TERMINAL			1
14							
15							
16							
17							
18							
19							
20							
21							
22							
23							

EXPLODED ASSEMBLY	PART NAME	PART CODE	STOCK NO.				
1/2	REMARKS	PART CODE	PART STOCK NUMBER	PART NAME	SPECIFICATIONS	SYMBOLIC OR EXPLODED VIEW NO.	QTY USED
1		APSAAD04AD		P.W. BOARD ASSY			1
2		APSPM042AD		P.W. BOARD ASSY			1
3		APSSM090AA		P.W. BOARD ASSY			1
4		APSZQ010AA		P.W. BOARD ASSY			2
5		APSZQ010BA		P.W. BOARD ASSY			2
6							
7							
8							
9							
10							
11							
12							
13							
14							
15							
16							
17							
18							
19							
20							
21							
22							
23							

EXPLODED ASSEMBLY	PART NAME	PART CODE	STOCK NO.				
1/2	REMARKS	PART CODE	PART STOCK NUMBER	PART NAME	SPECIFICATIONS	SYMBOLIC OR EXPLODED VIEW NO.	QTY USED
1		APSAZ03AA		P.W. BOARD ASSY			1
2		APSLD035AA		P.W. BOARD ASSY			1
3							
4							
5							
6							
7							
8							
9							
10							
11							
12							
13							
14							
15							
16							
17							
18							
19							
20							
21							
22							
23							

EXPLODED ASSEMBLY	PART NAME	PART CODE	STOCK NO.				
1/2	REMARKS	PART CODE	PART STOCK NUMBER	PART NAME	SPECIFICATIONS	SYMBOLIC OR EXPLODED VIEW NO.	QTY USED
1		MW401CX003		SHORT JUMPER			1
2		MW401CX004		SHORT JUMPER			1
3		MW401CX005		SHORT JUMPER			1
4		MW401CX006		SHORT JUMPER			1
5		PSC80052CX		PRINTED W. BOARD			1
6		P5LD038COX		P.W. BOARD			1
7		QLBLN217RN		L.E.D.	LN217RP RED	LED1 LED2 LED3 LED4	6
8						LED5 LED6	
9		QLBLN317GN		L.E.D.	LN317GP GREEN	LED7 LED8	2
10		QLBLN524AN		L.E.D.		LED9	2
11		VK2218W002		HOLDER			4
12		VQ6115R001		SPACER			1
13		WTG507EEXX		SOLID WIRE		N01	1
14		WTG612EEXX		SOLID WIRE		N02	1
15		ZZZ0000129		P.C. JOINT		JU3 JU4	2
16		ZZZ0000135		P.C. JOINT		JU1	1
17		ZZZ0000136		P.C. JOINT		JU2	1
18		ZZZ0000138		P.C. JOINT		JU5	1
19		ZZZ0000149		F-BRIDGE WIRE		JU5	1
20							
21							
22							
23							

EXPLODED ASSEMBLY	PART NAME	PART CODE	STOCK NO.				
1/2	REMARKS	PART CODE	PART STOCK NUMBER	PART NAME	SPECIFICATIONS	SYMBOLIC OR EXPLODED VIEW NO.	QTY USED
1		CEAC2215LY		ELYT. CAPACITOR	220MF 10V	C8	1
2		CEAD1024XN		ELYT. CAPACITOR	1000MF 16V Z-TYPE	C3	1
3		CEQ1568201		ELYT. CAPACITOR		C1 C2	2
4		CKDE103PEM		CERAMIC CAP.	0.01MF 500V -0. +10% F	C4 C5 C6 C7	4
5		MW201B5001		TERMINAL			20
6		MW401CX006		SHORT JUMPER			1
7		PSPM042COX		P.W. BOARD			1
8		QDSG32XX0		SILICON DIODE	GM32 NO-RANK	D1 D2 D3 D4	4
9		QDSW02MXG		SILICON DIODE	W02M VRN=200 33.3MHZ	D5	1
10		QDZ809FXBA		ZENER DIODE	RD9.1E VZ=9.12-9.69V B-1AVC	D6	1
11		QTC1096XAA		TRANSISTOR	2SC1096 L.H-RANK 3MM STRAIGHT-TYPE	Q1	1
12		RD25PJ271X		CARBON FILM R.	0.25W 270 OHM 5%	R3	1
13		RD25VJ102X		CARBON FILM R.	0.25W 1K OHM 5%	R4	1
14		RG2ANJ152N		M-OXIDE FILM R.	2W 1.5K OHM 5%	R1 R2	2
15		SP028AX02A		PUSH SWITCH		S1	1
16		YHFOP0001Z		FUSE HOLDER			6
17							
18							
19							
20							
21							
22							
23							

EXPLODED ASSEMBLY		PART NAME	PART CODE	STOCK NO.			
REMARKS		PART CODE	PART STOCK NUMBER	PART NAME	SPECIFICATIONS	SYMBOLIC OR EXPLODED VIEW NO.	QTY USED
1		CKCB473ZFM		CERAMIC CAP.	0.047MFD 50V -20, +80% F	C200	1
2		PSSW090C0X		P.W.BOARD			1
3		YJ005006Z		DIN JACK		J7	1
4		ZZZ0000035		P.C. JOINT			1/ 12
5							
6							
7							
8							
9							
10							
11							
12							
13							
14							
15							
16							
17							
18							
19							
20							
21							
22							
23							

EXPLODED ASSEMBLY		PART NAME	PART CODE	STOCK NO.			
REMARKS		PART CODE	PART STOCK NUMBER	PART NAME	SPECIFICATIONS	SYMBOLIC OR EXPLODED VIEW NO.	QTY USED
1		PSZQ010C0X		P.W.BOARD			1
2		QTC2496XAN		TRANSISTOR	2SC2486 P.O-RANK	Q37 Q38	2
3							
4							
5							
6							
7							
8							
9							
10							
11							
12							
13							
14							
15							
16							
17							
18							
19							
20							
21							
22							
23							

EXPLODED ASSEMBLY		PART NAME	PART CODE	STOCK NO.			
REMARKS		PART CODE	PART STOCK NUMBER	PART NAME	SPECIFICATIONS	SYMBOLIC OR EXPLODED VIEW NO.	QTY USED
1		PSZQ010C0X		P.W.BOARD			1
2		QTA1062XAN		TRANSISTOR	2SA1062 P.O-RANK	Q39 Q40	2
3							
4							
5							
6							
7							
8							
9							
10							
11							
12							
13							
14							
15							
16							
17							
18							
19							
20							
21							
22							
23							

EXPLODED ASSEMBLY		PART NAME	PART CODE	STOCK NO.			
REMARKS		PART CODE	PART STOCK NUMBER	PART NAME	SPECIFICATIONS	SYMBOLIC OR EXPLODED VIEW NO.	QTY USED
1		ML466SE001		COVER.L		9B	1
2		ML466SE002		COVER.R		9C	1
3		MUB96SE001		TOP COVER		9A	1
4							
5							
6							
7							
8							
9							
10							
11							
12							
13							
14							
15							
16							
17							
18							
19							
20							
21							
22							
23							

EXPLODED ASSEMBLY	PART NAME	PART CODE	STOCK NO.			
REMARKS	TUNING_FLY_ASSY	AVFLYML013				
1	PART CODE	PART STOCK NUMBER	PART NAME	SPECIFICATIONS	SYMBOLIC OR EXPLODED VIEW NO.	QTY USED
1	AVFLYML014		FLYWHEEL ASSY		7A	1
2	B5PP3006NN		PAN HEAD SCREW	(+BIT, M3 X 6 S-NI	7E-1 7E-2	2
3	BWK40705TJ		FLAT S. WASHER	FLAT SMALL, 4 M/M TEFLON	7D-1 7D-2	2
4	MT376B0002		BEARING		7C	1
5	MT644B0001		SHAFT		7B	1
6						
7						
8						
9						
10						
11						
12						
13						
14						
15						
16						
17						
18						
19						
20						
21						
22						
23						

EXPLODED ASSEMBLY	PART NAME	PART CODE	STOCK NO.			
REMARKS	FLYWHEEL ASSY	AVFLYML014				
1	PART CODE	PART STOCK NUMBER	PART NAME	SPECIFICATIONS	SYMBOLIC OR EXPLODED VIEW NO.	QTY USED
1	MR2955H001		FLYWHEEL		7A1	1
2	MT363B0008		BUSHING		7A2	1
3						
4						
5						
6						
7						
8						
9						
10						
11						
12						
13						
14						
15						
16						
17						
18						
19						
20						
21						
22						
23						

EXPLODED ASSEMBLY	PART NAME	PART CODE	STOCK NO.			
REMARKS	KNOB ASSY	AVKN08*116				
1	PART CODE	PART STOCK NUMBER	PART NAME	SPECIFICATIONS	SYMBOLIC OR EXPLODED VIEW NO.	QTY USED
1	HN233A001		GAP		8B	1
2	VE2875B001		KNOB		8A	1
3						
4						
5						
6						
7						
8						
9						
10						
11						
12						
13						
14						
15						
16						
17						
18						
19						
20						
21						
22						
23						

 **Cybernet****Head Office**

344 Shinsaku, Takatsuku,
Kawasaki, Kanagawa 213
Japan

Tel: 044-888-1111
Telex: 3842-426

Europe**CYBERNET EUROPE S.A.**

Mercure Centre,
Raketstraat 100,
B-1130 Brussels
Belgium

Tel: 02-720-9020
Telex: 63136

U.S.A.**CYBERNET AMERICA INC.**

99 Sherwood Avenue,
Farmingdale,
N.Y. 11735
U.S.A.

Tel: 516-752-8577
Telex: 230640452
