



SPEAKER  
SYSTEM KIT  
80W/3 WAY 3 SPEAKER

12SA-7

eller  
Michael Otto  
Classic.de

© beim Hersteller  
Archiv Michael Otto  
HiFi-Classic.de

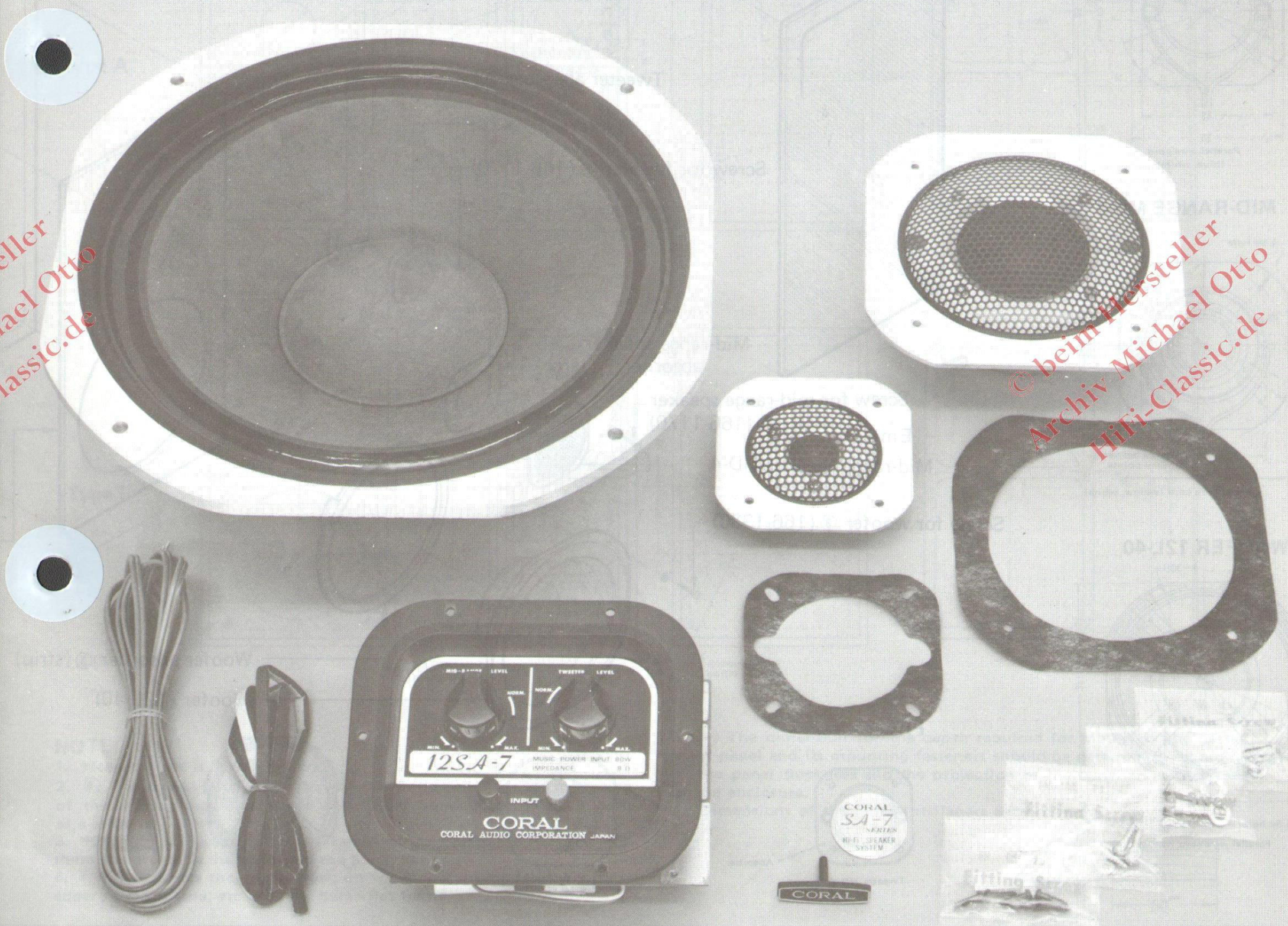

CORAL AUDIO CORPORATION

Thank you very much for your purchase of the CORAL Speaker System Kit 12SA-7.

The SA-7 is another in CORAL's impressive array of top-quality speaker kits. As with all our other series, the SA-7 has been designed and built based on our own superior audio engineering skill, which dictates use of only the most advanced acoustic materials and theories. We point with pride to the SA-7 as a new landmark in a whole family of speaker kits, which includes our famed TS-series, introduced back in 1963, and our SA-1 and SA-3 series.

The fun of a kit lies in being able to build a speaker system economically to your own liking—and being very well able to obtain a performance better than that available from commensurate ready-made speaker systems.

Speaker enclosures for our SA-7 series kits may be selected from two designs (large and small). Too, the design data provided for the woofer enables the enjoyment of personal speaker enclosure design and experimentation. Not only will you be able to say that you did it; you will be further gratified by being the happy possessor of a high-quality speaker system that can only provide the utmost in listening delight.

The 12SA-7 3-way 3-speaker kit comes with a 30cm woofer for the low frequencies, a 6.6cm semi-hard dome speaker for mid-range and a 2cm hard dome super-tweeter for the highs—a system of the highest quality capable of delivering a sumptuous array of the most accurately reproduced sounds ever over the entire aural spectrum.

The CORAL Speaker System Kit 12SA-7—let your hands create enjoyment for your ears.

#### WOOFER

- Rigid aluminum diecast non-resonant frame with more-than-ample thickness precludes even very weak resonance and completely rules out frame distortion. The handsome functional design of the machined frame helps create an impressive overall appearance for the system.
- A large 140mm-diameter ferrite magnet equipped with a holed top piece is included in the magnetic circuit, minimizing distortion caused by non-linearity at large amplitude and permitting powerful low-sound reproduction with effective damping.
- The cone paper, made of a special impregnating agent and choicest pulp, is specially pressed (we've sacrificed the possible profits which could result from mass-production) to ensure just the right amount of internal loss plus strength that remains unaffected by air pressure inside the cabinet. The edge is liberally hand-layered with damping material and completely filled to improve linear movement and damping efficiency. Combined, these features assure smooth sound reproduction from super-lows through medium range with minimal distortion.
- Large 70mm-diameter special heat-proof resin-treated voice coil guarantees high input-resistance.

#### MID-RANGE SPEAKER

- The ideal diaphragm requires an elastic material free from specific resonance. For this reason, the diaphragm of our MD-4 features an exclusive textile of special select fibers coated with three layers of damping material. The resultant damping efficiency is amazing. So is the low-distortion sound reproduction from the mid through high frequencies.

- The pole of the magnetic circuit has a through hole which directs smooth changes in pressure from the rear of the diaphragm to the back cavity. The vibrating area and the interiors of the pole through hole and back cavity are filled with different acoustic materials, eliminating internal standing waves and unwanted resonance. Too, the reduction of low resonance frequency ( $f_0$ ) by use of the back cavity and acoustic material effectively damps resonance at  $f_0$ , enabling smoothest woofer sound reproduction with minimum distortion.
- The powerful magnetic circuit which boasts a big 110mm-diameter ferrite magnet applies powerful driving and damping forces on the vibration system. The result: good, clear sound.
- CCAW used in the large 50mm-diameter voice coil makes it light in weight, enabling it to maintain optimum mass balance with the diaphragm, thus expanding the high frequency range and greatly improving transient characteristics and resolution. The voice coil also features high heat resisting properties since it receives the same special heat-resisting resin-treatment as the woofer.
- The rounded Duralumin frame is machine finished and specially treated, creating a functional appearance similar to the woofer.

#### TWEETER

- The diaphragm uses ultra-thin 18-micron-thick super Duralumin, which has been heat-treated in a precision electric furnace, in order to meet the requirements for lightness in weight and rigidity, and to provide high-frequency response that far exceeds the audible range.
- Wide-diffusion equalizer provides outstanding directivity and high-frequency characteristics.
- Light-weight voice coil with edge-wise winding of high-conduction aluminum alloy ribbon wire fully utilizes the high magnetic flux density

of the precision magnetic circuit. The voice coil—in combination with the rigid, light-weight diaphragm—is extremely efficient and provides superb transient characteristics and resolution.

- The rounded Duralumin frame is machine finished and specially treated, creating an appearance similar to the woofer and mid-range speaker.

#### DIVIDING NETWORK

- A constant-impedance, continuously-variable attenuator is provided for the tweeter as well as the mid-range speaker, enabling smooth level control.
- A large ferrite core with a high permeability and an impedance-compensating circuit are used for the woofer, preventing non-linear distortion at the time of large input and providing outstanding transient characteristics.
- A metallized polyester condenser, which has a high quality factor, low loss characteristics and high input-resistivity, is employed for the tweeter and the mid-range speaker, providing excellent transient characteristics and creating sound quality with high resolution ability.
- A printed circuit board ensures high reliability.
- AMP tips are provided at the lead ends, allowing firm connections to be made easily without soldering.

#### ENCLOSURE

The enclosure is a "do-it-yourself" affair. It should have an inner volume of 50~100l. No other specific requirements. This manual contains drawings for two different types (A and B). An enclosure kit (Model EK-55) and a baffle board (Model 55B-12A), both equivalent to the Type A enclosure, are separately available.

FIG. 1 DRAWINGS OF RECOMMENDED ENCLOSURES

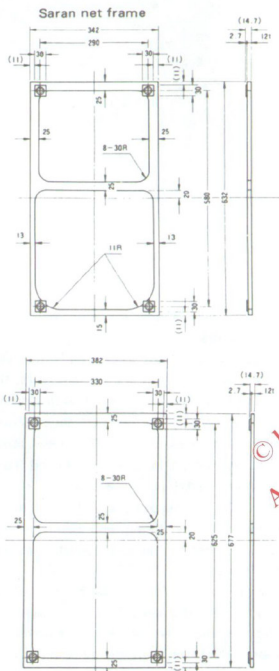
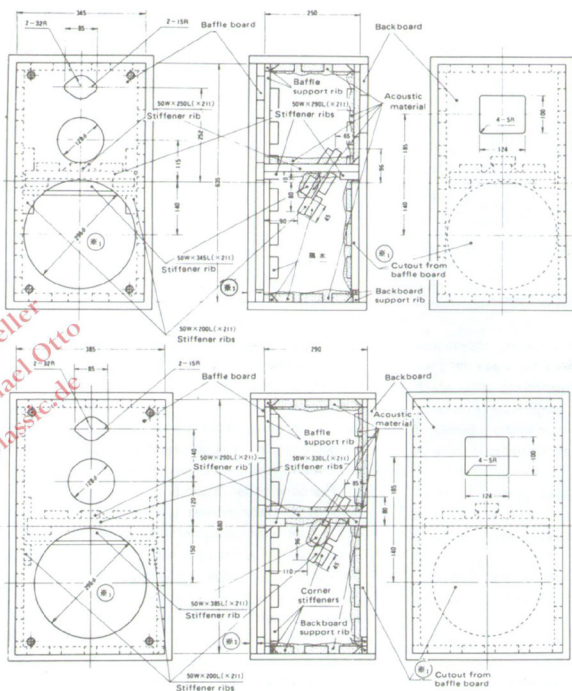
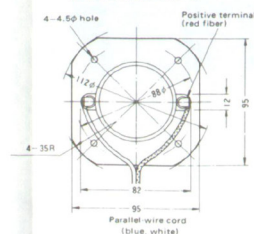
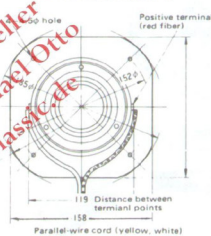

FIG. 4

TWEETER HD-2



MID-RANGE MD-4



WOOFER 12L-40

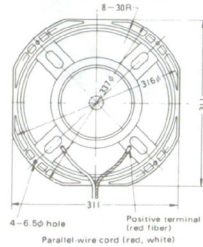

FIG. 3

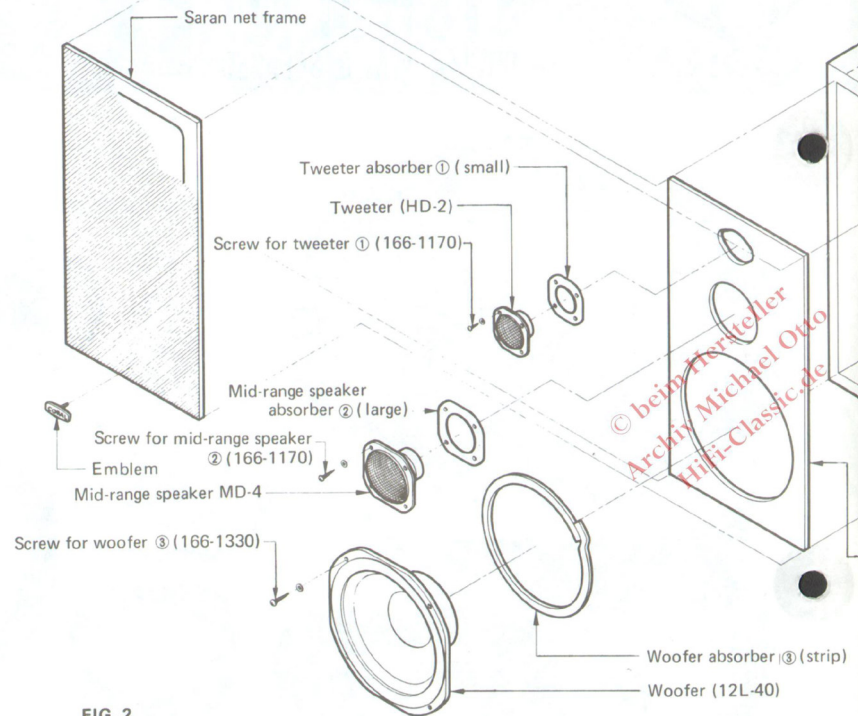
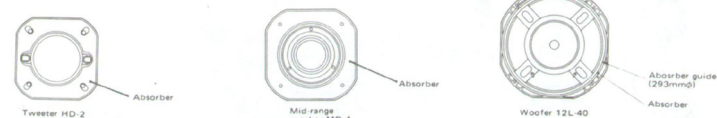

FIG. 2



Type A

Type B

NOTE:

1. Measurement is in millimeters.
2. (⊕) The round portion cut out of the baffle board for the mounting of the woofer should be sawed and firmly bonded to the backboard as a stiffener.
3. 12mm-thick Luan plywood board or particleboard is used for these enclosures as the frame for the Saran net.
4. (⊕) indicates the center position for the mounting fasteners (self-adhering cloth tape, etc.) for the Saran net frames.

5. (⊕) The dimension for the depth required for mounting the netted front panel and its mounting fasteners should be determined according to the panel thickness and the projection of the panel from the front of the enclosure.
6. Dimensions of the corner stiffeners shown below.

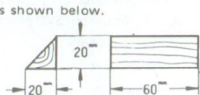

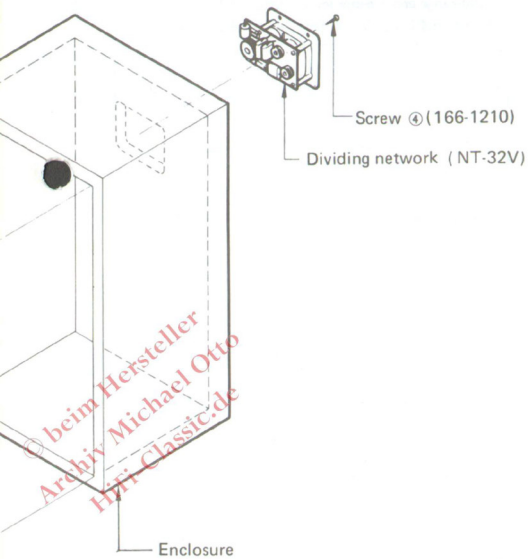

## HOW TO ASSEMBLE THE 12SA-7 SPEAKER SYSTEM

### ENCLOSURE-MAKING

1. Drawings are shown in Fig. 1 for the two types of enclosures designed for the 12SA-7 system.
2. Luan plywood board or particleboard with a thickness of more than 20mm is ideal.
3. Be sure to use woodworking bond and assemble in the proper manner so as not to cause any disparity.
4. To fix the Saran net over the frame, use a piece approximately 10cm larger (vertically and horizontally) than the size of the frame, wrap the frame with the net by folding the edges over the back of the frame, and secure the folded edges with staples. Care should be taken to stretch the net fully in all directions without distorting the flow of the fabric pattern and leaving sags, which could cause unwanted vibration. Cut off the excess edge portions of the net after stapling. The net may be moistened by spraying with water prior to its application for better results.
5. The net can affect the performance of the speakers. Good material with proper sound transmission should be used to prevent the net from flapping in the low-frequency range and unfavorably damping high-range sound.
6. The net frame should be mounted on the baffle board by means of fasteners that are commercially available.
7. Glass wool or felt should be used as acoustic material. It should be applied to the top, bottom, right and left of the enclosure interior as well as to the backboard by bonding in a thickness of approximately 25mm.

### WIRING AND SPEAKER-MOUNTING

(See to Figs. 2 to 6)

Be sure to make starting holes when using wood screws.

1. Speaker absorbers should be used to ensure that each speaker is snugly mounted air-tight on the baffle board.
2. Paste the absorbers provided on the back of the tweeter and the mid-range speaker after peeling off the backstrip, as shown in Fig. 2. Re the woofer, apply the absorber strip along the absorber guide on the back edge in a circle as shown. The ends of the strip should be overlapped as shown in Fig. 3, and the remaining length should be cut off.

Applying absorber on the woofer

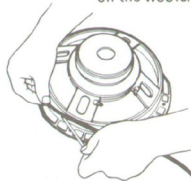

3. Attach the dividing network to the backboard with the screws provided, as shown in Fig. 3. Since the printed circuit board of the network is larger than the mounting hole in the backboard, insert the circuit board first by slanting.
4. Insert the proper wiring (identified by colors) into the hole for the corresponding speaker and pull it out. If the cord inside the enclosure is too long and dangling, clamp it properly to the enclosure using staples or some equivalent means.
5. Wire first the tweeter, then the mid-range speaker, then the woofer; then mount them securely as shown in Fig. 3.
6. Wiring should be made by firmly inserting the AMP tip of each cord to its corresponding lug terminal after confirming polarity and color of the parallel-wire, as shown in Figs. 4 and 5. The white wire in each lead is for negative connection.

FIG. 6

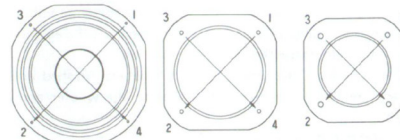

The screws of each speaker should be tightened in the order shown.

7. Each speaker must be secured with the wood screws and washers provided in diagonal order as shown in Fig. 6. Tighten the screws until each speaker is snug against the baffle board to preclude speaker vibration. The absorber strip of the woofer should be flat on the baffle board. Be careful not to let the screwdriver slip and damage the speakers when tightening screws.
8. This completes the wiring and mounting of the speakers.

### PERFORMANCE TEST

1. The 12SA-7 is designed for an impedance of 8 Ohms. The amplifier should therefore have an optimum load impedance of approximately the same value.
2. Connect the input terminals of the completed speaker system to the output terminals of the amplifier with the accessory cord after confirming the proper polarities.
3. Set both tweeter and mid-range speaker level control knobs on the dividing network at their MIN (minimum) positions.
4. Using a musical source of good quality (tape, record, FM broadcast, etc.), set the volume of the amplifier at its MINIMUM position, then turn on the amplifier.
5. Gradually increase the volume of the amplifier and check to determine if sound emits from the woofer. Then gradually turn the level

FIG. 5

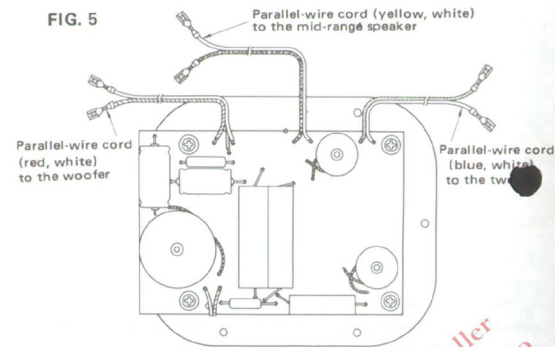

- control knob of the dividing network clockwise to check if sound is reproduced through the mid-range speaker and the tweeter.
6. Set the level control knobs at their NORMAL positions and listen to determine if well-balanced sound is being reproduced by each speaker. If satisfactory, set the level control knobs to taste.
7. If there is no sound, or if an abnormality is detected, turn off the amplifier and check all wiring.

### CAUTION

1. When using the system in combination with another system, such as a stereophonic system, the polarities of the connections between the amplifier output terminals and the speaker system input terminals must definitely conform. If they do not, and thus supply different phases to the system, not only will the performance of the speakers be marred but the stereophonic effect will also be adversely affected.
2. The speaker system is best positioned with a solid wall at the back. Bass sounds may become too prominent when the system is directly placed on the floor, so it is better to raise the system 20~30cm above the floor by placing it on a sturdy base, such as blocks. Proper precautions should be taken with respect to the surroundings, since furniture and windows can cause unwanted resonance.
3. Refrain from using the speakers when they are not mounted. If it is absolutely necessary to do so, however, keep the input power at a comparatively low level.

Specifications herein are subject to change without notice in order to effect improvements.

## SPECIFICATIONS & CHARACTERISTICS OF 12SA-7

### Specifications of Speakers

Model	Woofers 12L-40	Mid-range MD-4	Tweeter HD-2
Input impedance	8Ω	6Ω	8Ω
Low resonance frequency ( $f_0$ )	34Hz	—	—
Output sound pressure level (1W 1M)*	94dB	95dB	96dB
Rated frequency response	$f_0 \sim 3,000$ Hz	650~10,000Hz	8,000~40,000Hz
Magnetic flux density**	9,300 Gauss (930mT)	16,500 Gauss (1,650mT)	13,000 Gauss (1,300mT)
Total magnetic flux**	218,000 Maxwell (2,180μWb)	150,000 Maxwell (1,500μWb)	20,000 Maxwell (200μWb)
Weight	4,160g	1,650g	380g

\* JIS C-5531  
 \*\* Values in parentheses are in the International System of units (SI).  
 T: Tesla (1T=10<sup>4</sup> Gauss) Wb: Weber (1Wb=10<sup>8</sup> Maxwell)

#### Additional woofer specifications (for reference)

Effective radius of diaphragm:	12.4cm
Effective mass of vibrating system:	57g
$\alpha_0$ (impedance-increasing ratio at $f_0$ ):	11.0 (mean)
Qm:	5.7 (mean)
Qo:	0.52 (mean)

### Performance of 12SA-7 in Recommended Enclosures

	Enclosure A	Enclosure B
Enclosure type	Air-tight	
Speaker system	30cm 3-way 3-speaker	
Input impedance	8Ω	
Low resonance frequency (for reference)*	55Hz	50Hz
Output sound pressure level (1W 1M)	93dB	
Frequency response	30~40,000Hz	25~40,000Hz
Music power input	80W	
Crossover frequency	650Hz : 8,500 Hz	

\* Variable depending on the quality and quantity of the acoustic material used.

### PARTS LIST FOR 12SA-7 KIT

Item	No./Spec.	Q'ty	Code, etc.
Woofers	12L-40 (8Ω)	1	
Mid-range	MD-4 (6Ω)	1	
Tweeter	HD-2 (8Ω)	1	
Dividing network	NT-32U	1	
Accessory cord	Grey, parallel	1	
Acc. screw (1)	For tweeter	1	166-1170
" (2)	For mid-range	1	166-1170
" (3)	For woofer	1	166-1330
" (4)	For dividing network	1	166-1210
Acc. absorber (1)	For tweeter	1	Small
" (2)	For mid-range	1	Large
" (3)	For woofer	1	Strip
Emblem	CORAL mark	1	
Name plate		1	

### CHARACTERISTICS OF 12SA-7 IN TYPE-A ENCLOSURE (Mid-range and tweeter level controls at NORM.)

#### Electrical impedance/frequency characteristics

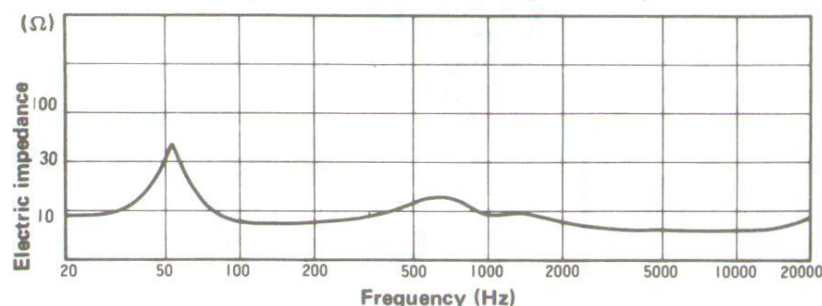

#### Harmonic distortion/frequency characteristics

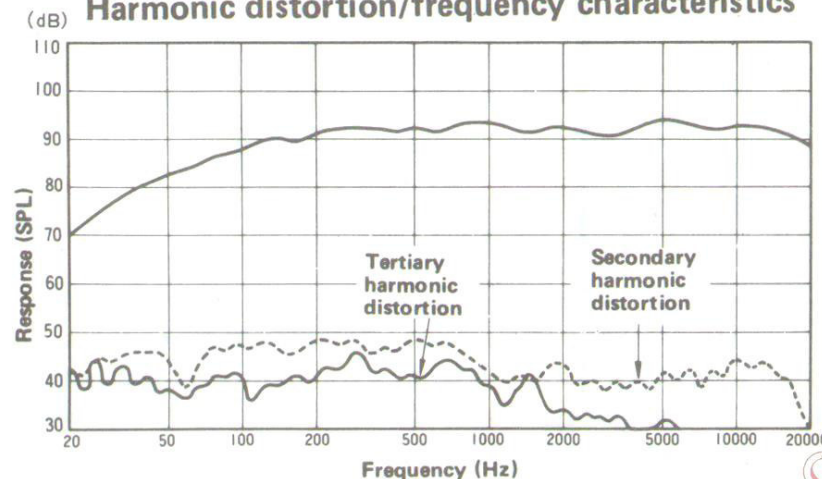

#### Level control variation/frequency characteristics

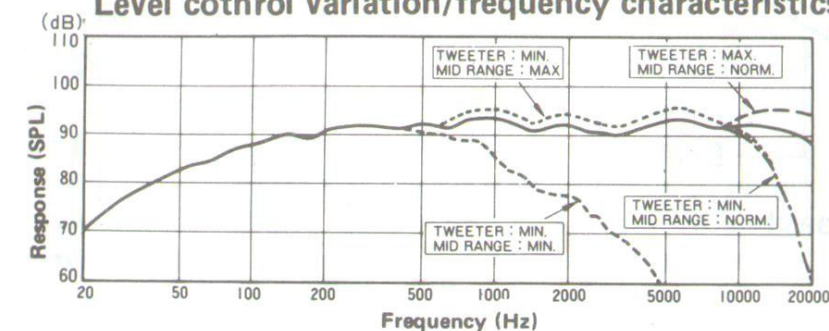

#### Directional frequency characteristics

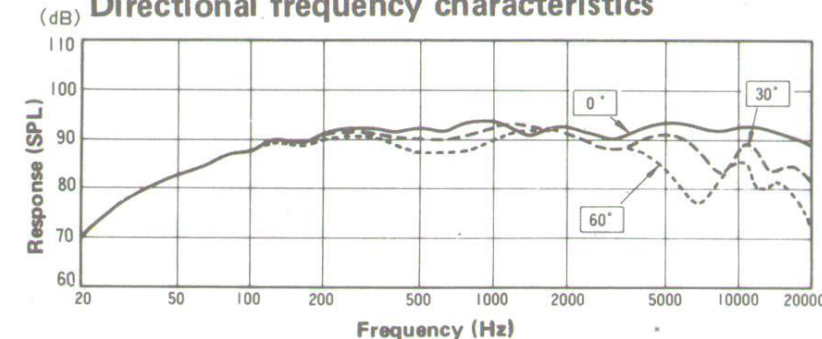

**CORAL AUDIO CORPORATION**

1-1-6, Shibashimo, Kawaguchi-shi, Saitama-ken, Japan