

THE BOSE 901 — A SERIES OF TECHNICAL ARTICLES

**The technology
behind
THE BOSE 901**

BOSE[®]
DIRECT/REFLECTING[®] SPEAKER SYSTEMS

This article is one of a series explaining the features and benefits of the Bose 901 — the most highly reviewed speaker regardless of size or price.



What's behind the BOSE 901

DIRECT/REFLECTING®

Speaker System?

If you have heard the BOSE 901 DIRECT/REFLECTING® speaker system, or if you have read the unprecedented series of rave reviews, you already know that the 901 is the longest step forward in speaker design in perhaps two decades. Since the performance of the 901, covered by U.S. and foreign patents issued and pending, derives from an **interrelated group of advances**, each depending on the others for its full potential, we hope you will be interested in a fuller explanation than is possible in a single issue.

In this issue, we'd like to tell you what our research revealed about the roles of direct and reflected sound in the reproduction of music. The direct sound is what you would hear if the walls and roof of the concert hall were removed. If you have ever listened to an orchestra outside, without a reflecting shell, you know that it is very soft and dull compared to what you experience in the hall. The difference is the reflected sound.

The reflected sound comes to your ears from the walls of the concert hall in almost equal quantities from all directions whereas the direct sound comes to you from the direction of the instruments. The direct sound is responsible for your sense of localization while the reflected sound contributes to the fullness, presence and warmth of the concert hall performance. As the research indicates, "this spatial property of the sound incident upon a listener is a parameter ranking in importance with the frequency spectrum of the incident energy for the subjective appreciation of music."*

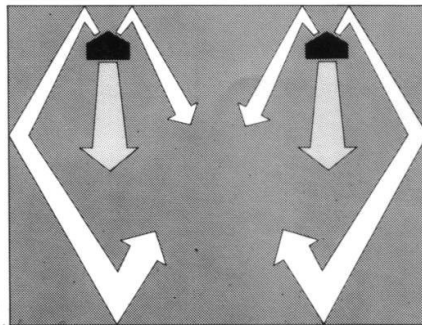

HOW THE 901 INCORPORATES THESE FINDINGS

The 901 has eight speakers on the back panels and one on the front. This accomplishes two objectives. First, it radiates the desired ratio of about 89% reflected sound to 11% direct sound. Secondly, by proper choice of the angles of the rear panels (see fig.) the 901 projects the image of a musical performance

spread across a stage that is located about two feet behind the speaker. This image is established to the extent that it is possible to hear the full stereo spread from a wide range of listening positions including directly in front of one speaker — a feat that is not possible with conventional speakers.

This concept of direct and reflected sound would result in an improved speaker by itself but it would fall far short of providing the realism offered by the 901. There are three other essential advances that must be used in combination with the direct and reflected sound to obtain the full benefits offered by the 901. These will be the subjects of other issues.

*From 'ON THE DESIGN, MEASUREMENT AND EVALUATION OF LOUDSPEAKERS', Dr. A. G. Bose, a paper presented at the 1968 convention of the Audio Engineering Society. Copies of the complete paper are available from the Bose Corp. for fifty cents.

BOSE®
Framingham, Massachusetts 01701

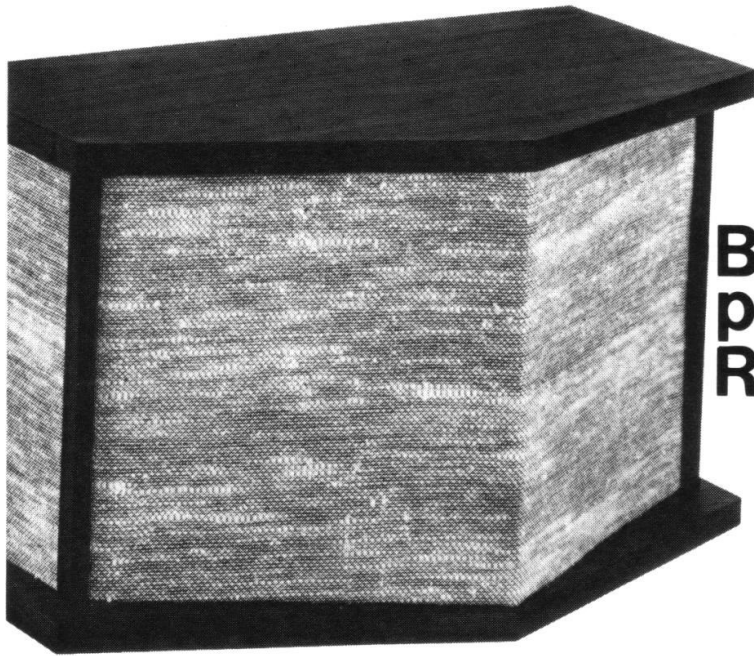

BOSE puts you in the REVERBERANT FIELD

Handwritten signature

We've mentioned in another issue that the "spatial property of the sound incident on a listener is a parameter ranking in importance with the frequency spectrum of the incident energy for the subjective appreciation of music."* By 'spatial property', we mean the directions from which the sound arrives at the listener — not the direction in which the sound leaves the speaker.

Yet though it is as important as frequency response, spatial property has played little part in the design of speakers prior to the 901. Measurements of a speaker, on-axis in an anechoic environment, deliberately avoid spatial property ('room effects') because in order to measure spatial characteristics, the speaker and the room must be considered as a system. No way was previously known to distinguish the contribution of the speaker from that of the room.

In a room, "the Sound Pressure Level drops off as the distance from the source increases until the direct field becomes smaller than the reverberant field. Beyond this point, the intensity is independent of distance and its variation with room position is a function only of the standing wave pattern in the room." This becomes significant for loudspeaker design "when we examine the sound field in concert halls and find that for virtually all seats, the reverberant field is dominant. Even for a large hall such as Symphony Hall in Boston, the reverberant field equals the direct field at about 19 feet from the source." In the reverberant field, "since the energy in this field arrives at any point via reflections from the surfaces of the room, the angles of incidence of the arriving sound energy are widely distributed. . . .

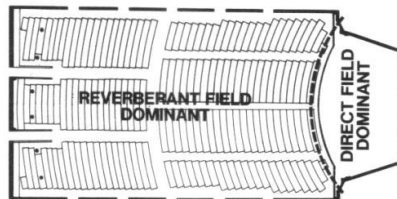

**BOSTON SYMPHONY HALL
FLOOR PLAN**

Conventional speaker design however results in the dominance of the direct field from the loudspeakers with the consequent localization of stereo sound in two points and the noticeable lack of fullness or openness of the reproduced sound."*

How The 901 Incorporates These Findings

The use of the Direct/Reflecting® technique in the 901, with only 11% direct sound, is designed to simulate the concert hall experience by placing the listening area in the reverberant field, rather than the direct field. The stereophonic experience of the listener is uniform throughout the room. The speakers vanish as point sources — even to a listener directly in front of one speaker. Instead, they project the image of the musical performance across the entire wall behind the speakers.

These spatial characteristics are combined with three other essential advances to produce the full range of benefits offered by the 901. They are the subjects of other issues. Meanwhile, if you'd like to hear what spatial property means, ask your franchised BOSE dealer for an A-B comparison of the 901 with the best conventional speakers he carries, regardless of size or price.

Handwritten signature

How does the BOSE 901 eliminate audible RESONANCES?

The best known feature of the BOSE 901 is its Direct/Reflecting[®] design, which copies the proportion of direct to reflected sound measured in the concert hall. But aiming a speaker at a wall does not magically give it greatness. What is not yet so well known is that even in conventional terms the 901 is a better speaker — a more precise instrument than other speakers for converting an electrical into an acoustic signal. The primary source of this precision is the use of an array of 9 same-size, full-range, acoustically coupled speakers in each 901. In the research that led to the 901, a digital computer was used to simulate an ideal vibrating surface "having no resonances, phase shift, diffraction, or distortion of any kind." It was then proved (and demonstrated at a professional group meeting of the I.E.E.E. in Nov. 1964) that a multiplicity of closely spaced, acoustically coupled, full-range speakers "can produce music and speech signals in a

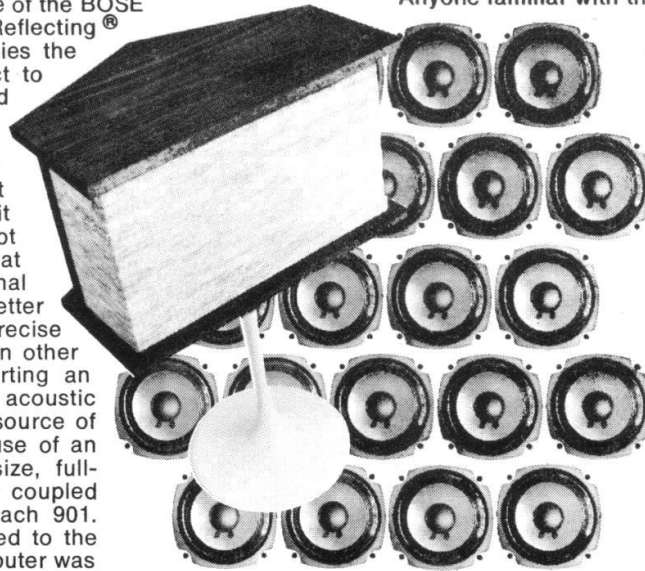

normal listening environment that are subjectively indistinguishable from those that would be produced by an ideal pulsating sphere in the same environment." *

Any speaker has many inherent resonances — frequencies where its response is irregular. Our research determined that when many similar speakers are closely spaced and acoustically coupled to a common chamber, the resonant frequencies of each speaker diverge from those of every other speaker. As a result, each resonance becomes inaudible, since it causes a change in the output of only one speaker of the many.

Anyone familiar with the problems of resonances in conventional speaker design will appreciate how important a discovery this is. In the case of the 901, it means that only one speaker out of 9 can be in resonance at a time — a proportion which is inaudible. The resultant freedom from audible resonances and other forms of distortion helps to account for the utter clarity and honesty of musical performance for which the 901 has already become famous. For the present, if you would like to hear the difference that a multiplicity of full-range speakers can make (in combination with 3 other major advances), ask your franchised BOSE dealer for an A - B comparison of the 901 with the best conventional speakers — *regardless of their size or price*. Then, go back to your present speakers — if you can.

BOSE on the reproduction of BASS

In other issues of this series we have explained how a multiplicity of same-size, full-range, acoustically coupled speakers "eliminate(s) the sound coloration caused by resonances of speaker systems using only a small number of speakers and by irregularities in the radiated energy spectrum of systems employing crossover networks."* But how does the use of 4 inch, full-range speakers allow such spectacular bass performance? It has always been assumed that large woofers in large enclosures are required to deliver full bass response. The answer to this question lies in the fact that bass performance is purely a matter of how much air you can move and how well you can control its movement. In the 901, this depends on four interrelated features.

A) *The 'Array Effect'*, by which a group of proximate small speakers, moving in phase, acts like one large speaker with the area of the group.

B) *The Special Design of the Drivers Used in the 901.* These are special long-excursion, high compliance speakers with large magnets, which can move large amounts of air.

C) *Use of the Well-Controlled Frequency Region Below Fundamental Resonance.* In conventional speaker design the fundamental resonance is pushed as low as possible and the region below this is discarded

for music reproduction. Contrary to convention, the fundamental resonance of the 901 is designed *upward* to about 200 Hz. The reasons for this departure are:

- 1) Below 200 Hz, phase irregularities are much more audible than above 200 Hz.
- 2) Any speaker exhibits strong phase irregularities in the region of and above its fundamental resonance.
- 3) Below fundamental resonance, these irregularities are absent. Both amplitude and phase characteristics are very smooth functions of frequency *and are electronically equalizable.*

Thus the 901, by having its fundamental resonance designed at 200 Hz, allows us to make use of this region of smooth response to reproduce bass instruments with unprecedented accuracy of timbre.

D) *Active Equalization.* Since phase and amplitude are very smooth below fundamental resonance, it is possible through active equalization to control the amplifier signal to maintain flat radiated power down to lower frequencies than even the largest conventional speakers can produce. Ask your franchised BOSE dealer for an A-B comparison test with the best conventional speaker systems, *regardless of their*

size or price. Listen especially for the deep accurate bass of the 901 in contrast to the artificial bass (excessive response between 80 Hz and 200 Hz) which is often mistaken in conventional speakers for good low frequency response, but whose thumping and droning cause listener fatigue.

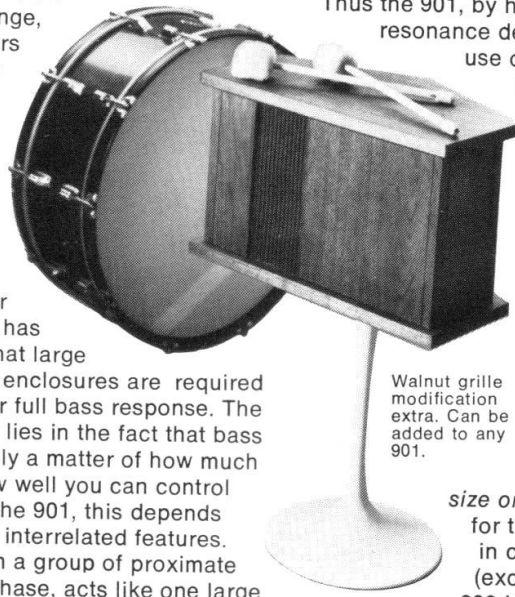

Walnut grille modification extra. Can be added to any 901.

Johnson

Why BOSE eliminates woofers, tweeters and CROSSOVERS

Equally important, the directionality (dispersion) of a speaker varies with its diameter. Therefore, the spatial characteristics of the sound can change sharply in the crossover region as the radiation shifts from the large woofer to the small tweeter. "This spatial property of the sound incident upon a listener is a parameter ranking in importance with the frequency spectrum . . . for the subjective appreciation of music."*

The principal reason which had been put forth in favor of the use of crossovers was the reduction of possible doppler distortion.

(When a high frequency note is emitted from a speaker core which is 'slowly' moving toward or away from the listener while it is also reproducing a bass note, is the frequency of the higher note affected audibly?) Measurements and computations in support of this hypothesis have been based on sine waves, on one axis, in an anechoic environment. No correlation has been established between these numbers and what we hear with music and speech signals, in a room. In another issue, on the subject of DISTORTION, we shall explain how we were able to prove (in an experiment which is reproducible by

In other issues we describe how a multiplicity of same-size, acoustically coupled speakers eliminates audible resonances and, in addition, makes possible the unprecedented bass performance of the BOSE 901 Direct/Reflecting speaker system. But there is yet another vital benefit from this advance — the elimination of crossovers.

The best answer which had previously been found, for reproducing the full audio spectrum with dynamic speakers, was the use of a large speaker for the bass frequencies and smaller speakers for the higher frequencies, with crossover networks routing the appropriate frequencies to the appropriate speakers. (see fig.) Crossover networks, whether they are passive in the speakers or electronic in amplifiers, are generally designed so that the sum of the voltages at 'B' and 'C' is proportional to the speaker input signal at 'A'. This would be adequate only if the speakers were themselves perfect for then we might have an acoustical signal at 'D' which bore a close relation to the speaker input 'A'. However, woofers and tweeters are far from ideal. They exhibit both phase and amplitude irregularities in the crossover region. Phase differences between the woofer and tweeter, for example, can cause the cone of the woofer to advance while the cone of the tweeter is retreating. The result is sound coloration caused by the fact that the sum of the output of the woofers and tweeters is widely varying in the region of the crossover frequencies.

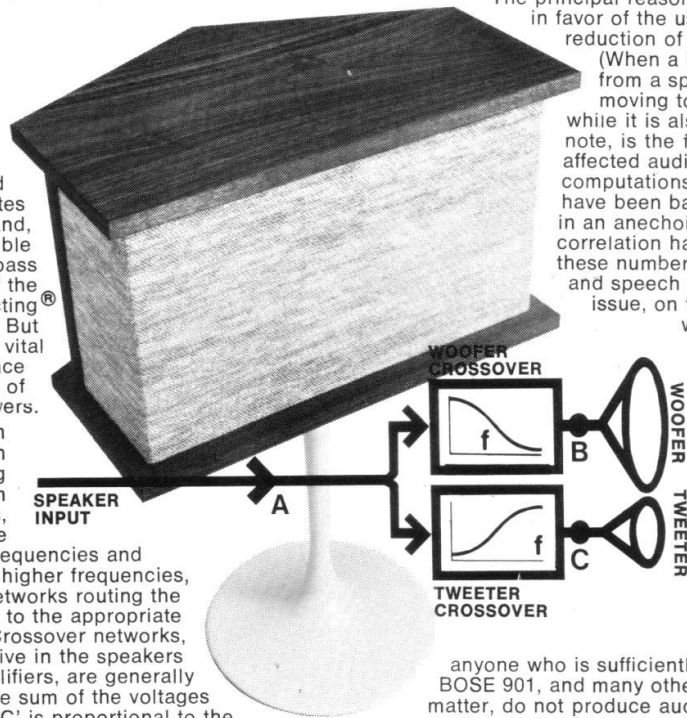

D LISTENER
Block Diagram of Conventional Speaker System Employing Woofers, Tweeters and Crossovers.

anyone who is sufficiently interested) that the BOSE 901, and many other good speakers, for that matter, do not produce audible doppler distortion on music or speech.

If you would like to hear the performance of a speaker with no woofers, tweeters or crossovers (and several other major advances), ask your franchised BOSE dealer for an A - B comparison of the BOSE 901 with the best conventional speakers he carries— *regardless of their size or price.*

Why doesn't every speaker system have an EQUALIZER?

3. The fundamental resonance of conventional speakers lies in a low frequency range (below 100 Hz) for which the ear is very critical of both amplitude and phase irregularities. Despite many attempts over the past decades, no really successful solutions have been found for the equalization of conventional speakers through the frequency range of their fundamental resonance.

We can now ask: HOW DOES THE 901 USE THE FULL POTENTIAL OF EQUALIZATION?

1. By using a large number of *acoustically coupled* full-range speakers, we take advantage of 'resonance-splitting' (See our issue on RESONANCES).

Equalization is required for only the smooth average curve rather than for the complicated individual speaker characteristics.

2. The crossover problem is eliminated by the use of nine full-range speakers.

3. In the 901, the fundamental resonance is designed upward to near 200 Hz in order to

The principle of equalization is depicted in the accompanying block diagram. An input signal X passes first through an equalizer and then component S (a speaker, for example) to reach the output Y. Component S is said to be equalized when the response of the equalizer is complementary to that of component S, to create the desired uniform response of the overall system from input X to output Y. When we consider that this concept is used throughout engineering from (all) phonographs and tape recorders to complicated television and communication systems, we naturally wonder why every speaker doesn't have an equalizer.

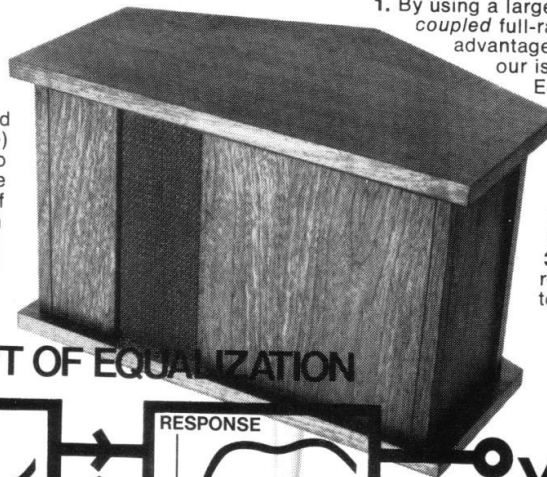

CONCEPT OF EQUALIZATION

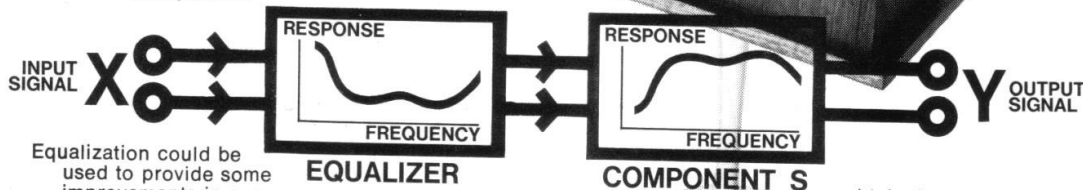

Equalization could be used to provide some improvements in conventional speakers.

But the results would fall far short of realizing the full potential of equalization. The possible benefits would be restricted, even negated, by a number of practical constraints. There would be a high probability of introducing more sound coloration than was removed.

PROBLEMS IN EQUALIZATION OF CONVENTIONAL SPEAKERS

1. Any mechanically vibrating membrane manifests many irregularities (normal modes) which are individually too complex to equalize.*
2. No satisfactory solution has ever been obtained for the equalization of a speaker system over the crossover region where two speakers of grossly different amplitude, phase and spatial radiation characteristics are attempting to make an acoustical transition.

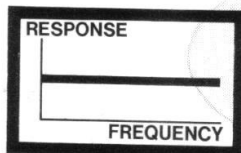

OVERALL RESPONSE FROM X TO Y OF EQUALIZED SYSTEM

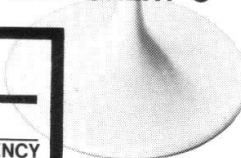

obtain the smoothest possible phase and amplitude response (ideal for equalization) in the critical region below 200 Hz (See our issue on BASS).

If you'd like to hear what equalization can mean in sheer clarity and smoothness of response, along with a number of other major (audible) improvements, ask your franchised BOSE dealer for an A-B comparison of the 901 with the best conventional speakers — *regardless of their size or price.*

BOSE on SOUND LOCALIZATION

When you stop to think, it is really demanding to expect a few microphones in the concert hall, and two speakers in a living room even to begin to recreate the listening experience provided by a wide stage on which perhaps 100 instruments are playing. Yet we try. It is easy to show that *no* two speakers (even ours) can recreate the live experience *exactly*. But there are speaker design factors that *can* be incorporated to produce significant improvements over conventional speakers.

One of these factors (And you may do simple experiments to verify it, using conventional speakers in your own home.) is the proper LOCALIZATION OF SOUND.

In a live performance the wall behind the musicians is one of the most important surfaces in the acoustical design of the hall. It reflects the sound to provide the fullness characteristic of live performances. (Even outdoors, a reflecting shell is a necessary part of good musical performances.) It is for the same reason that speakers should be designed to use one wall of a room to simulate the stage of a live performance. Since home rooms and speakers are smaller than stages and orchestras, good simulation requires that each speaker be capable of presenting a sound image that is broader (physically larger) than the dimensions of the speaker itself.

But how can a speaker accomplish this? Try the simple sequence of experiments indicated in Figure 1 and you will discover the answer. In experiment 1 you will localize the source of

the sound to *point A*, the speaker. Experiment 2 results in your localizing the source of sound primarily to *point C* on the side wall. Experiment 3, when both speakers are played together, results in your localizing the sound source as an *area* between points A and C. The experiment is fascinating; try it. After doing these easy experiments you will understand, in part, how the direct/reflecting® principle of the 901 creates a sound image much larger than the speaker and causes your ear to localize the source of sound as if it originated from a stage. Add to the direct/reflecting® design factor a multiplicity of full-range speakers, active equalization, and the criterion of flat spectrum of *power radiation** and you are in for a most pleasant surprise when you A-B the 901 with any conventional speaker, regardless of size or price. Your *franchised* Bose dealer can arrange the A-B experiment.

*See 'ON THE DESIGN, MEASUREMENT AND EVALUATION OF LOUDSPEAKERS', Dr. A. G. Bose, a paper presented at the 1968 convention of the Audio Engineering Society. Copies of the complete paper are available from the Bose Corp. for fifty cents.

1. Play Speaker A
2. Play Speaker B
3. Play Both Speakers—adjusting the relative volume levels (B greater than A) to give the best spatial image

Copies of the complete paper are available from the Bose Corp. for fifty cents.

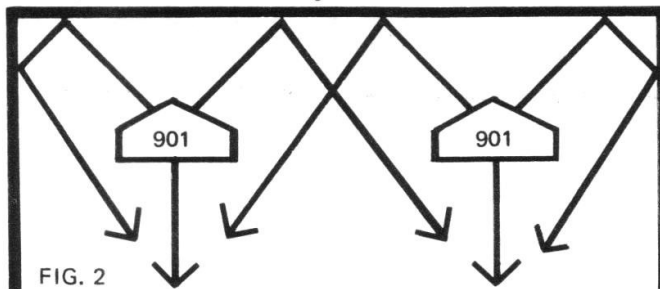
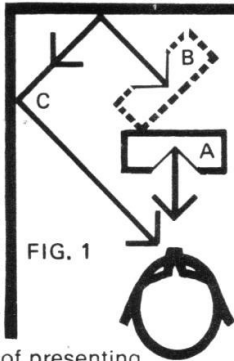
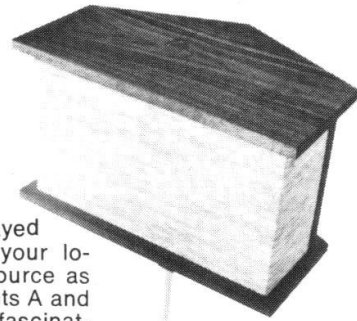

Why is the BOSE 901 designed for FLAT POWER RADIATION?

THE NEED FOR FLAT POWER RADIATION:

In previous articles we have explained that when you attend a concert, the reverberant field is dominant over the direct field at your seat. In order to create a similar situation in your living room, the speaker must use one wall of your room in the same way that the orchestra uses the back wall of the stage — to reflect sound. A fundamental property of the reverberant field is that its distribution of power vs. frequency is related, not to the radiation of a musical instrument along any one axis, but rather to the total power it radiates in all directions. Therefore, in order to more accurately simulate the live performance in your home, the loudspeaker must be designed for a flat power radiation into the room rather than flat frequency response on axis. The need for flat power radiation was first recognized in the research that led to the BOSE 901, and the 901 is the only speaker that uses this principle. The result — you can now listen to an ensemble of violins or other instruments playing in the higher registers of the musical scale and enjoy all the overtones and proper attacks without suffering from the annoying shrillness so characteristic of Hi Fi. (Musicians and many women are very sensitive to shrill and screechy sounds — they will instantly recognize the unique properties of the BOSE 901 in this respect. In fact, many owners have commented that their wives

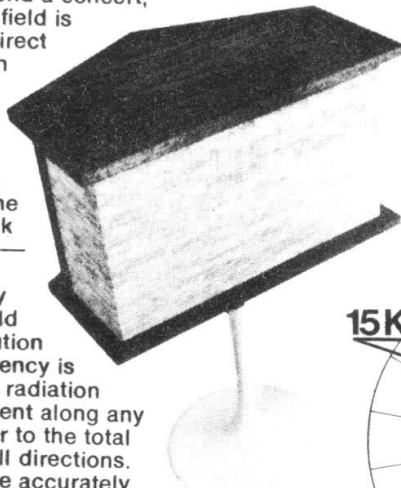

can enjoy the 901 at a much higher volume level than they could tolerate with conventional speakers.)

WHY CONVENTIONAL SPEAKERS CANNOT HAVE FLAT POWER RADIATION:

Figure 1 shows the measured directional radiation of one of the better conventional speakers at 50Hz and 15KHz. The fact that the two solid curves coincide on the speaker axis indicates that the speaker has the same response on-axis at the two frequencies. However, the much smaller radiation pattern at 15KHz (both horizontally and vertically) shows that the total power radiated in all directions at 15KHz is only a fraction of the power radiated at 50Hz. This is why you notice that the high frequencies drop off as you move off axis with a conventional speaker. If this speaker were to be equalized to radiate flat power, the on-axis response at high frequencies would be so intense (indicated by the dotted line) that you could not sit in front of the speaker. This problem is fundamental in conventional speakers.

(We leave it as an interesting exercise for the technically inclined reader to show that even a cylindrically shaped speaker cannot employ flat power radiation without excessive high frequency radiation toward the listening area.)

HOW IS FLAT POWER RADIATION POSSIBLE WITH THE 901?

— By directing the greater percentage of the radiation at precisely selected angles to the rear wall, the 901 achieves flat power radiation without high frequency beaming toward the listening area.

Ask your franchised BOSE dealer for an A-B comparison test with the best conventional speaker systems, regardless of their size or price. Note especially the absence of the 'Hi Fi edge' on the violins and the uniform distribution of the highs throughout the room.

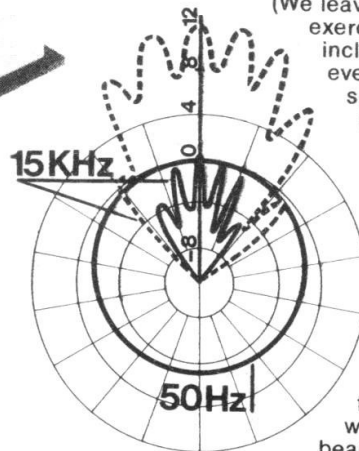

Handwritten signature

FEATURES & BENEFITS of the BOSE 901

TECHNICAL FEATURES* → PRODUCE → BENEFITS YOU CAN HEAR

A multiplicity of full range speakers acoustically coupled (to a common chamber)

1. Eliminates sound coloration produced by different-sized speakers with crossover networks. *The result is increased definition and clarity.*
2. The acoustic coupling disperses the many resonances of individual speakers to render them inaudible in the 901 array. *Instrumental sound is reproduced with greater accuracy.*
3. In any speaker most of the input power is dissipated as heat in the voice coil. By providing nine areas instead of one for heat dissipation, the 901 can handle much more power than conventional speakers. *able to say*
This means that the 901 is capable of a much larger dynamic range (the ratio of the loudest to the softest audible passages). With small amplifiers (30 watts per channel) the 901 has a dynamic range superior to most conventional speakers. With larger amplifiers, you will experience dynamic ranges you never thought possible in recorded music.

**DIRECT/REFLECTING®
One front speaker and eight rear speakers positioned at precisely calculated angles to the wall.**

1. Simulates the spatial properties of the direct and reverberant sound fields of a live performance: — *Much more of a sense of presence and realism* in which one wall of your room is used as the stage wall is used behind a live performance.
2. The precise ratio of reflected to direct sound and the angles of the reflections from the rear wall allow stereo listening *from almost any position in the room* — even 3 feet in front of one speaker.

FLAT POWER RADIATION

In a live performance you respond to the balance of the total acoustical energy radiated by an instrument, not to its frequency response on any axis. The 901 is designed to radiate this same balance of total acoustical energy. The result is that you can now hear the attack of instruments without the excessive screech that has for so long accompanied HiFi sounds. *gelled music*

**ACTIVE EQUALIZATION
Over 100 components precisely tailor the musical signal fed to the 901.**

Provides precise control over the acoustical radiation of the 901 at all audible frequencies: — Unprecedented accuracy of instrumental timbre.

These features and benefits of the 901 have been the subjects of the unprecedented series of rave reviews in all the major music magazines. The 1970 issue of *HIFI BUYERS GUIDE* comments on the other reviews and on the 901 as follows:

"Utilizing a 'new' approach to sound reproduction . . . the Bose 901 is capable of delivering some of the most natural sound ever heard from a speaker system. Its midrange and highs are magnificently transparent, its lows neither smeared nor boomy, its over-all sound quality so clean that the listener is almost unaware of the electronics between him and the instruments . . . Widely acclaimed by most anyone putting pen to paper, the 901 has been hailed again and again as a breakthrough in technology . . . The sound? The 901 is very possibly the only speaker to date to pour forth in true concert-hall fashion." *brunswick*

When you hear the 901 you will immediately notice its wide margin of (patented) superiority over any other speaker, regardless of size or price. Ask your franchised dealer to let you audition the 901 in your home on a trial basis. You have nothing to lose but your satisfaction with your present HiFi system.

*See 'ON THE DESIGN, MEASUREMENT AND EVALUATION OF LOUDSPEAKERS', Dr. A. G. Bose, a paper presented at the 1968 convention of the Audio Engineering Society. Copies of the complete paper are available from the Bose Corporation for fifty cents.



Technology must be confirmed by performance.

Here are the judgements of the most respected critics and reviewers.

"... I must say that I have never heard a speaker system in my own home which could surpass, or even equal, the Bose 901 for overall 'realism' of sound."

**Hirsch-Houk Laboratories,
STEREO REVIEW**

"The 901 is very possibly the only speaker to date to actually pour forth in true concert hall fashion."

HI FI BUYERS' GUIDE

BOSE ... the most highly reviewed speaker

"It is our opinion that this is the speaker system to own, regardless of price if one wants the ultimate in listening pleasure."

e/e HIGH FIDELITY

The complete text
of an unprecedented
series of rave reviews
of the BOSE 901
DIRECT/REFLECTING[®]
speaker
system

"But these speakers provide a quality which is not to be matched."

STEREO & HI FI TIMES

"I urge that you listen for yourself. I think you will have to agree that Bose has, in a single giant step, produced one of the finest speaker systems ever made."

AMERICAN RECORD GUIDE

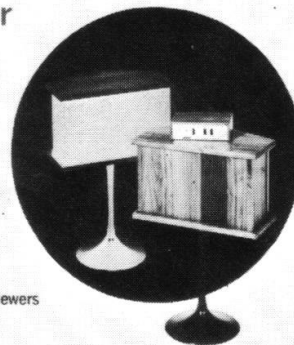

by
Equipment Reviewers
and
Music Critics

"... if your response to it is like ours, you'll be reluctant to turn it off and go to bed."

Norman Eisenberg, HI FIDELITY

"After a time trial measured in months rather than weeks, this one can definitely proclaim Bose is best, big or small, high or low."

**Irving Kolodin,
SATURDAY REVIEW**

**Available Free
at Bose Dealers.**

"To hear a thunderous 'low C' organ pedal . . . , or a clean, weighty impact of a bass drum is truly impressive . . . There is no doubt that the much abused and overworked term 'breakthrough' applies to the Bose 901 and its bold new concepts."

Bert Whyte — AUDIO

"The Bose have replaced forever our bulky studio speakers with compact, handsome units. The only trouble is — our studio is beginning to look like a living room!"

DOWN BEAT

You can now read **THE ULTIMATE REVIEW** by the owners themselves

The relevance of the research which produced the 901 and the value of the reviews rest solely upon your ultimate appreciation of the product. Every day we receive letters and comments from owners expressing an appreciation that goes far beyond the expected reaction to just another good product.

We decided to share these owner observations with you in a 68 page booklet that we believe makes some of the most fascinating reading in the field of high fidelity. It is entitled "The Owner Reports on the Bose 901". Included are letters from owners, warranty cards, and survey replies.

In it you can read the words of the owners on:

- 1 How different owners describe the esthetic experience of music and the sound of the 901.
- 2 What equipment owners use with the 901.
- 3 What equipment owners traded to buy the 901.
- 4 What happened when a customer tried to buy the 901 from a dealer that was not franchised.
- 5 What owners would like us to develop next.
- 6 What owners would like to see improved about the 901.
- 7 The influence owners have in selling the 901.
- 8 Candid remarks on many topics by people who, just like you, are searching for the best in stereo.

If your reaction is similar to the response of those who have already seen the booklet, you will read every page before putting it down.

And when you finish, you will know why we get much more satisfaction from our work than could ever be derived from profits alone.



Copies of "The Owner Reports" are available from BOSE Corporation for one dollar.

You can hear the difference now

BOSE[®]

BOSE CORPORATION, THE MOUNTAIN, FRAMINGHAM, MA. 01701