

# LOUDSPEAKER ENCLOSURES

## Their Design and Use

*© beim Hersteller  
Archiv Michael-Otto*

PRICE TWO DOLLARS

**ALTEC**  
The Sound of Experience

...and the waves were parted...

### The Enclosure

A well designed loudspeaker enclosure prevents front-to-rear wave cancellations, thus, greatly increasing the loudspeaker's ability to reproduce bass frequencies. The job of the enclosure is the control of rear wave action—relative to the front wave. To either completely prevent the rear wave from joining the front wave, or to control the manner in which the two wave forms are joined. A properly designed enclosure cannot make a poorly designed loudspeaker operate satisfactorily. Conversely, a well designed loudspeaker will not perform efficiently when housed in an enclosure of inferior design.

### Enclosure Size

A generalization can be made about loudspeaker enclosure size. We consider an enclosure of less than 2.0 cubic feet a bookshelf type, and those of 2.5 cubic feet or more as being a floor model. It is the intent of our publication to cover, and encourage, home construction of floor model systems—with the explicit intent of not covering bookshelf type systems.

The design variables in bookshelf systems are such that even the smallest variation in cubic volume, damping material, or panel stiffening—to a specific transducer—will provide wide variance in predicted acoustic results. However, the floor model is generally forgiving, in its acoustic results, when subjected to reasonable enclosure variables.

It is Altec's recommendation that bookshelf sized units be purchased as factory completed systems; that the floor model enclosure be encouraged for the home construction enthusiast. This publication intends to help show how to obtain best performance for a given size enclosure, with proper transducer matching, and how to allow for proper enclosure size for a specific loudspeaker or loudspeaker system.

### The Design and Use

Altec loudspeakers are precision transducers. Extra care and hand craftsmanship is evident in every step of production techniques. Engineering thoroughness is the byword in each Altec design. Bonuses in performance and reliability from manufacturing extras such as edge-wound voice coils and die-cast transducer frames are the standard at Altec rather than the theoretical ideal.

Each Altec transducer is designed with specific performance goals in mind. A



part of those performance goals is the enclosure design. Within the general guide-lines for each transducer, you will find how the enclosure can be varied to match your specific needs in regard to size or decor. It is not Altec's intention that you be tied to the specific duplication of a factory designed enclosure, but are allowed full rein of your imagination for adaptation, according to your requirements.

General cabinet construction technique is assumed by Altec to be known by the home builder. We will, however, cover those elements of construction requirements, assembly and materials, that are particularly applicable to loudspeaker enclosures. These guidelines are simple and you can give consideration to your home construction of a loudspeaker enclosure—even if this is the first project of your home workshop.

### Qualification

Our standard of qualifications is simple

—if you have access to a radial arm or table saw; if you have the inclination; if you can build a rigid, air-tight box—you can build your own loudspeaker enclosure.

### GENERAL DESIGN THEORY

Loudspeaker manufacturer is a term that is often misused and misunderstood. The reason is that there are really very few loudspeaker manufacturers in the audio industry. There are many loudspeaker assemblers, companies that purchase transducers from one manufacturer and then build their own enclosures, or perhaps buy these also, and market same under their name. Each year many of us anticipate what the new "break-through" in loudspeaker design will be—what will be discovered? And how will the advertising agency exploit the discovery in the market place? It is interesting to see how well yesterday's standards survive the test of time and how today's fads fall by the wayside.

### Billboard Magazine's 1974 Studio Data

ALTEC	522
JBL	339
EV	82
KLH	39
AR	34
TANNOY	24

# LOUDSPEAKER ENCLOSURES THEIR DESIGN AND USE

## INTRODUCTION

Altec has created this publication to provide a source of data from which audio enthusiasts can design and construct enclosures of predictable and satisfactory performance when used with Altec loudspeakers. For simplicity, at Altec, we think of the loudspeaker being the transducer, or raw frame, and a speaker being the completed system—including enclosure. It is not intended to contain information for all types of audio systems, such as theatrical and sound reinforcement systems or enclosure design principles not used in Altec factory-built systems. The concepts are presented from a practical standpoint, in order that the beginner may better understand the principles involved to design and build his own enclosure. To make music, not textbooks

## Function of an Enclosure

The purpose of the loudspeaker enclosure is to provide proper coupling between the loudspeaker transducer and the air into which the loudspeaker plays. The requirement for proper coupling is due to the piston-like action of the loudspeaker diaphragm when activated by a signal. If a loudspeaker transducer were freely suspended in the air, and then required to reproduce bass frequencies, little useful response would be obtained. The reason this occurs is the actual cone/diaphragm motion, which sets up a condition called "Phase Cancellation."

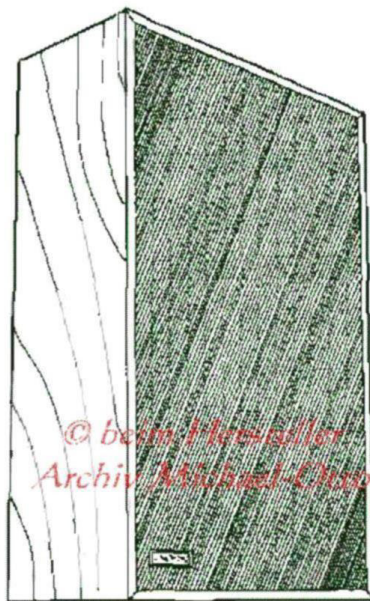

## The Loudspeaker Motion

The loudspeaker is essentially an air pump, converting electrical source energy into mechanical impulses, which are transferred to the air adjacent to the cone. To generate a desired audible tone, the loudspeaker cone must not only vibrate at the proper frequency, but must also set into motion a sufficient volume of air to create the vibration we perceive as sound. Sound waves are generated equally on both sides of the cone, but are opposite in their phase relationship.

When the cone moves forward, the air at the front of the diaphragm is compressed, while the air at the rear of the cone is rarefied. The reproduction of an audio signal requires that the loudspeaker diaphragm must move through both a forward and a rear directed motion with each hertz of signal. The opposite condition of compression and rarefaction is then created on the rear directed motion of the diaphragm. The effect is

illustrated in Figures 1A and 1B. Thus, each half-hertz of signal is created 180 degrees out-of-phase with the next successive half-hertz signal; this as the loudspeaker diaphragm completes its reproduction of each full-hertz signal. Such cancellations are detrimental to performance, and prevent the loudspeaker from transmitting the cone energy into usable response in the air of the listening area.

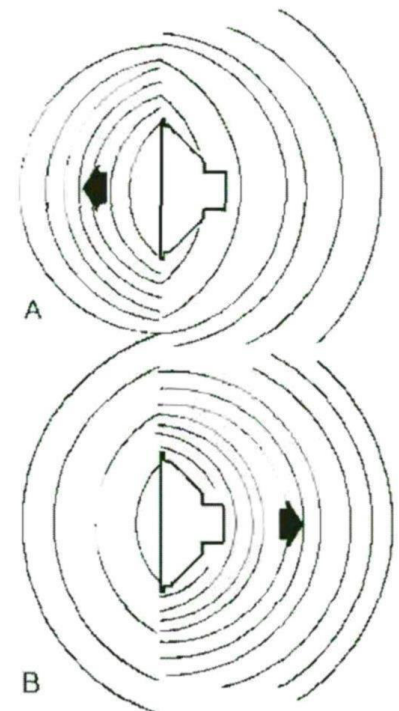
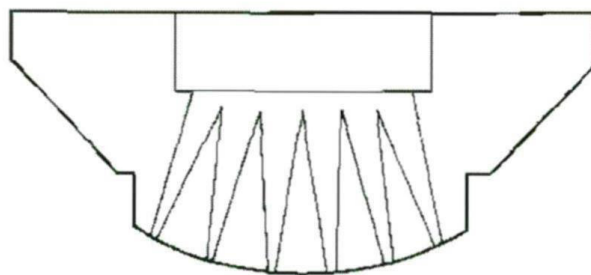
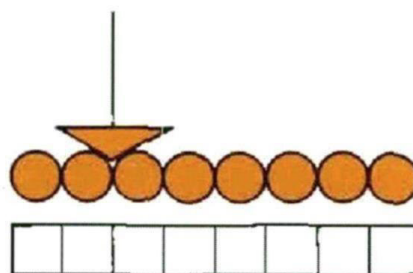
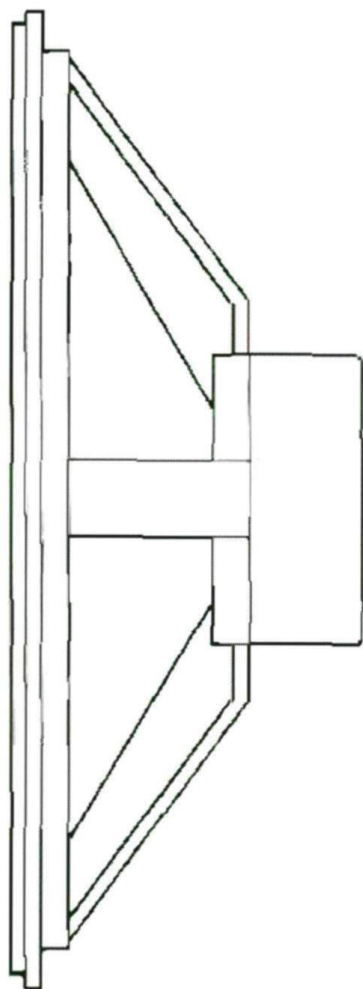

Figure 1



*© beim Hersteller  
Archiv Michael-Otto*

There is no "perfect" loudspeaker system. Contrary to a company that exclusively markets one type of enclosure design, which then has to be best. Altec recognizes the need for *different* requirements. Horn, reflex, infinite baffle, electrostatic, push, pinch, squeeze, resistive, capacitive—all are known parameters. The use of an individual concept can have its engineering performance gain, but always at some cost. Cost can be not only in direct dollars, but in performance negatives such as distortion or power handling. For a given size and price range, definitions can start to be discussed for the best in that category. The broad parameters Altec uses in its factory floor model systems is available to you. To choose as best fits your budget, space, and listening habits.

For high fidelity component systems, the design goal should be to reproduce as much of the full audio spectrum as possible without significant distortion. Selection of components should be planned for compatibility: efficiency, impedance, and frequency response. Compatibility of Altec components to themselves is included in the system charts later in the publication. While it is possible to mix

various brands of components, the predictability of results is limited, by Altec, to our knowledge of our own transducers.

Design parameters will cause the performance of component loudspeakers to vary widely. Make sure that your selection is designed for high fidelity reproduction, as well as the ability to match the associated components used in the system. In addition to published information, Altec will be happy to answer consumer questions regarding the match of various Altec loudspeaker models

There is one prime design philosophy of Altec to which all our loudspeaker transducers are built. This is the goal of highest performance accuracy under the most stringent extremes of volume range and power levels. Altec's position of leadership as the supplier of studio monitors to recording industry is unchallenged. In both United States and world-wide usage, Altec is the most accepted line of monitor speakers. United States usage shows Altec's leadership with more studios using our loudspeaker systems than the next five competitors combined. The point of this design goal is to achieve

accuracy and freedom from distortion at all volume levels. While average listening room volumes may never exceed sound pressure levels of 75 to 90 dB, your Altec floor model system will deliver sound pressure levels well in excess of 100 dB, if so desired, with the highest performance levels.

Studio monitor design, and studio monitor usage, dictates the other parameter of recommended transducer placement. Today, the recording studio has as major a part of the creative recording effort as the artists themselves. Modern recording and microphone techniques utilize tremendous effort on the part of the producer and recording engineer to create on the recording the proper balance of hall acoustics and ambience. This can only be properly re-created in the listening room when you hear the recording playback as the studio engineer heard it at mix-down—in the predominate direct field of an accurate loudspeaker. This *direct-firing*, forward-facing placement of the loudspeaker components in the enclosure will give the closest reproduction to the studio standard, and also minimizes problems in detrimental room acoustic problems.

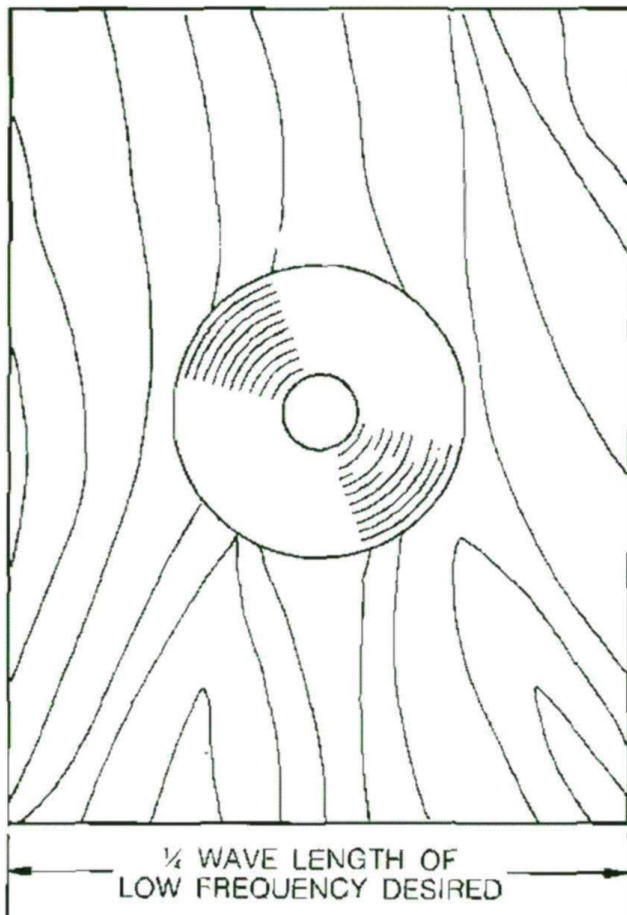

Figure 2

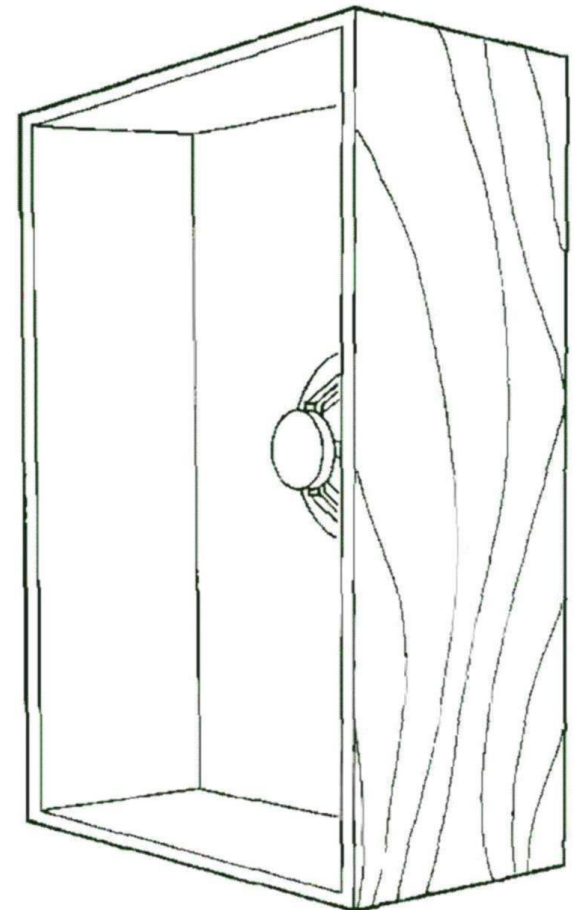

Figure 3

© beim Hersteller  
Archiv Michael-Otto

### ENCLOSING THE LOUDSPEAKER TRANSDUCER

The enclosure, as outlined in our introduction, keeps the bass frequency waves at the front of the loudspeaker cone from being cancelled by those waves created at the rear of the cone. The simplest approach is to isolate the air adjacent to the front of the loudspeaker from the adjacent rear air with a large flat baffle. In order to be effective, the baffle needs to be large enough to delay the rear wave radiation to the baffle edge by one-quarter wave-length of the lowest frequency to be reproduced, as in **Figure 2**.

When the rear wave has travelled from the back of the loudspeaker around the one-quarter wave-length baffle, and joins the front wave, it is delayed in total by one-half wave length—thus, now in phase with the front wave radiation. Due to the long wave-length of low frequencies, it would be necessary for a flat baffle to be 5.6 or 9.4 feet wide to reproduce frequencies of 100 Hz and 60 Hz respectively. The difficulty of the size required makes the flat baffle impractical for home use.

### Open Back Baffle

An open back baffle as illustrated in **Figure 3**, is essentially a flat baffle turned back on itself in an effort to decrease the linear size. It is not classified as an enclosure specifically, but the same basic characteristics of the flat baffle will remain. Open backed baffles are not used in true high fidelity loudspeaker systems, or where quality sound reproduction of the lower frequency spectrum is desired. Making the baffle deeper only approximates a tuned pipe, and does not allow adequate control of the resonant peaks occurring in the enclosure/loudspeaker combination. Closing the back of the baffle alters the characteristics, depending on the total size or entrapped volume of the enclosure. As the back of an open back baffle is closed, one must then look at the properties of the infinite baffle.

### Background Theory

Prior to the discussions of specific enclosure designs, further background on some specific areas is helpful. One of these is resonance, and the other is our preoccupation with the effect of the enclosure on only the low frequencies.

### High Frequency Reproduction

A special baffle is generally not as necessary for the reproduction of high frequencies as it is for low frequencies. One of the reasons is, at the higher frequencies, the loudspeaker diaphragm is moving at a much higher rate, and the shorter wave lengths that result do not transverse the front-to-back distance as easily as in the lower frequencies.

High frequencies have a tendency to be directional in character. Low frequency wave forms are more omnidirectional in nature, and spread in all directions. There are some high frequency transducers that are bipolar; their mounting in the enclosure and their action is really the same as the free-suspended transducer. In this instance, the directional characteristics of the higher frequencies help keep problems to a minimum—except as influenced by room placement. A bipolar device, when close to a wall, will reflect the high frequencies back into the direct sound field. This will cause phase cancellations at specific frequencies, which will vary due to the distance of the transducer from the reflective surface. Generally, the

## ...speed limits impede, announcers resonate...

closer the bipolar device is to the reflective surface, the more severe the phase cancellation problem.

Most high frequency transducers, whether compression driver/horns, direct radiators — cone or dome, will absorb the rear wave within the unit's frame or cover. Thus, most high frequency transducers handle the rear directed wave form as though a small infinite baffle.

### The Effect Of Low Frequency Resonance and Impedance

The nominal rated impedance of a loudspeaker refers not to an absolute, but instead to an average or minimum impedance that occurs, generally, in the mid-bass frequencies. The reason is that a loudspeaker is an inductive device and its impedance will vary with the frequency of the applied signal. The term, impedance, refers to the combination of the loudspeaker's electrical resistance and inductance when an AC signal is applied.

In addition to the electrical resistance, the loudspeaker has varying mechanical resistance—this because the loudspeaker is an electro-mechanical device. Mechanical resistance refers to the ease of setting a mechanical device in motion for a given motivating force. The natural resonance of a loudspeaker is that point where the diaphragm will vibrate most freely. It is at resonance that a loudspeaker's impedance varies most widely from the nominal level.

As the impedance rises, reducing the power available from the amplifier, the mechanical resistance to motion of the loudspeaker lowers, enabling the output to remain relatively linear. Variation in cone size and weight, coil depth and weight, and magnet size and gap, all influence the impedance resonant characteristics. The speaker output will fall rapidly below resonance, and we shall be concerned only with the generalities of resonances—not with the details of how to create this effect with that variable.

The two areas of our concern are the resonances called loudspeaker free-air resonance and system resonance. The free-air resonance refers to that resonant frequency when the transducer is free-suspended and not near any reflective surfaces. The system resonance refers to that resonant frequency which occurs when the transducer is mounted in the enclosure.

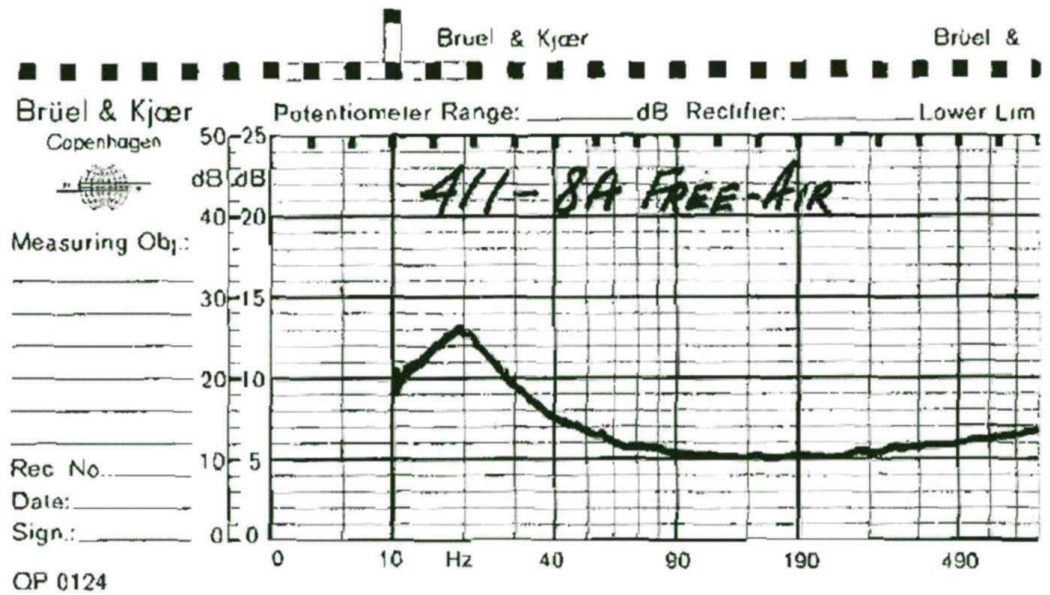

A

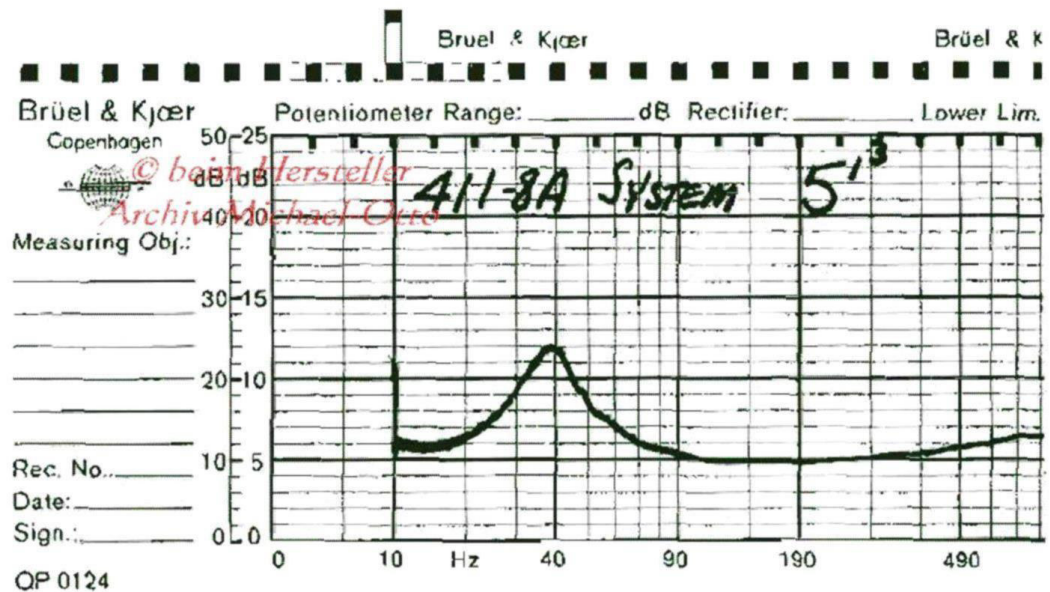

B

Figure 4

The free-air resonant frequency of a given transducer will be a constant. The system resonance will vary primarily with the method of baffling and the volume of air in the enclosure. Our prime concern with resonance will deal with the effect of system resonance on performance.

An example of the change of resonance from free-air condition to system mounting is illustrated in Figures 4A and B. Figure 4A shows the free-air resonance of an Altec 411-BA low frequency transducer. Figure 4B illustrates the low fre-

quency system resonance of the same transducer in the factory 878B enclosure. As we consider the enclosure size desired, we have to look at the effect of system resonance relative to size. Basically, as enclosure volume is made larger, system resonance will shift to a lower frequency. With this lower resonance, bass frequencies can be more easily reproduced by the system. It is Altec's recommendation to choose as large an enclosure as you can comfortably live with—within the limits recommended for the particular transducer.

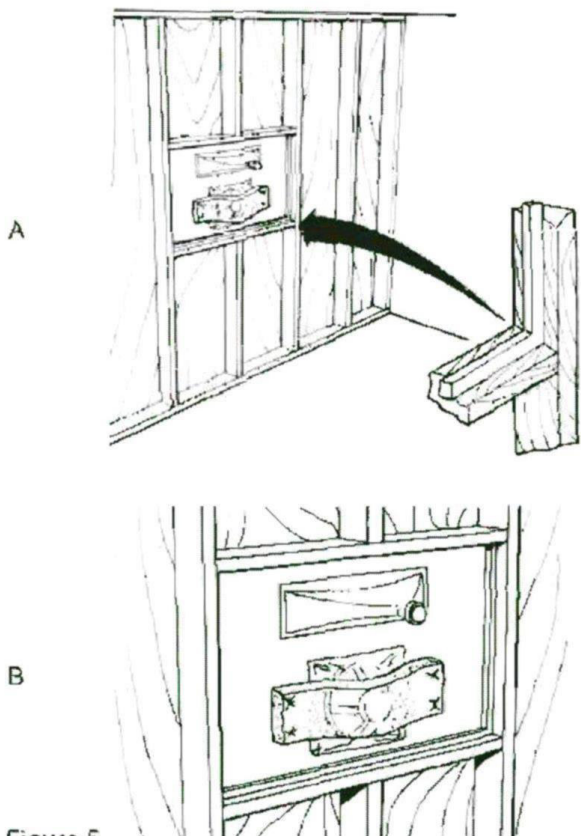

Figure 5

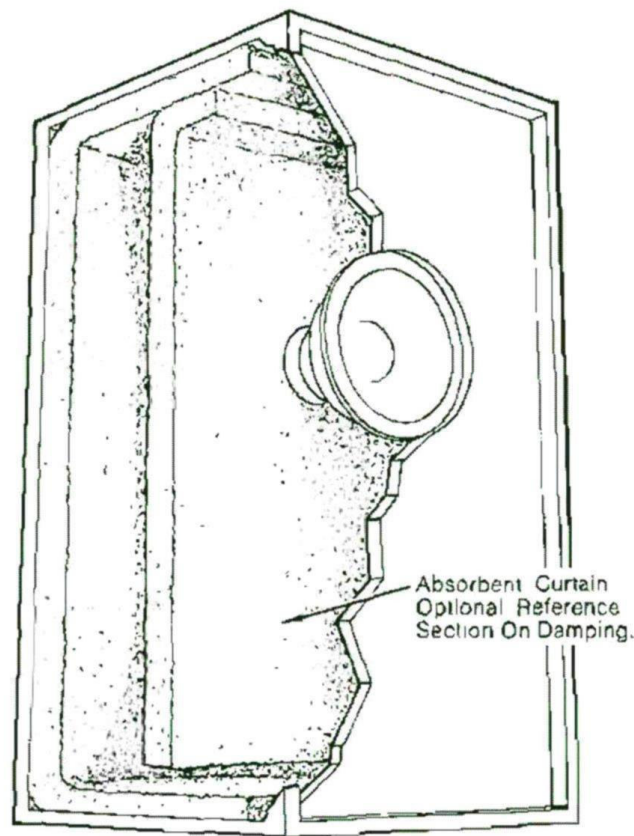

Figure 6

### The Infinite Baffle

The properties of the infinite baffle are complex—yet simple. Complex because there are four types of infinite baffles, and simple because of their ease of use. Each type needs to be investigated separately.

### Flat Baffle

The simplest infinite baffle would be the large flat baffle discussed earlier. If it were large enough to allow reasonable reproduction down to the deep bass frequencies, we could call this baffle of the infinite type. To reproduce a 40 Hz frequency note would call for a baffle of over 14 feet in width. When the loudspeaker is mounted in a true infinite flat baffle, the low frequency output should be fairly smooth, from the midband frequencies downward, till system resonance is reached. At this point we would expect a slight rise in response, and then a roll-off occurring at a rate of about 12 dB per octave. The response will then vary with the system resonance created by the particular transducer.

### Wall Baffle

While the large flat baffle is generally impractical, a modification of this approach is very practical in certain applications. Many homes and listening

rooms are such that one can use a wall as a flat baffle. Such an arrangement precludes the need for the large dimensional size, if the wall structurally keeps the rear wave from joining the front wave. If we were to mount the speaker in an outside wall, and use the world for the absorption of the rear wave, we would have the largest possible infinite baffle. This would be rather impractical due to both weather and appearance, but the rear wave absorption into another room or closet is a strong possibility.

Selection of proper components for this application requires some thought to the free-air resonance of the loudspeaker. As will be discussed in the section on air or acoustic suspension, some transducers are specifically designed with very high compliance suspensions and/or extremely low free-air resonances for use in the air suspension type enclosure. The wall type baffle should not be used for this type of transducer. The application chart included in this publication will enable you to choose the proper loudspeakers for this application.

The use of the wall baffle requires following some simple general rules. The rear wave must be easily dissipated into the space behind the transducer—generally a minimum cubic volume of 12 to 15 cubic feet. The transducer should be

mounted on a sturdy speaker baffle of at least 3/4-inch thickness, and the baffle appropriately mounted in the wall. There should be no air leaks around the edge of the mounting baffle, and effort should be made to insure there are no resonances set up in adjacent panels of wall board or wood paneling.

When using a spacing between three wall studs, headers should be used to rebrace the wall properly, as in **Figure 5A**. Once the wall space is cleared to handle a speaker mounting baffle, the baffle can be easily held in place with cleats used to line the opening, as in **Figure 5B**.

The later section of the publication dealing with speaker damping material is applicable to the wall baffle application. It may or may not be required—but a layer or two of fiberglass can be stapled across the back of the low frequency transducer if needed. It is a good general practice to separate the fiberglass from the loudspeaker with a layer of coarse muslin as in **Figure 5B**.

### Enclosed Infinite Baffle

The enclosed infinite baffle, or sealed enclosure, completely isolates the rear sound wave, preventing interference with the front wave. Sound absorbent material is required within the enclosure as a means of absorbing the acoustic energy

from the rear of the loudspeaker cone. If the sealed enclosure volume is significantly large to absorb the full output of the back wave, air loading on the diaphragm is not disrupted and the sealed enclosure functions with nearly the same properties as the true infinite baffle. Enclosures of this nature, as in **Figure 6**, are generally towards the large size, but are relatively easy to build and can easily be adapted to many transducers.

### Air or Acoustic Suspension Infinite Baffle

The term "air suspension" or "acoustic suspension" has been popularized through the acceptance of this type infinite baffle in many of the bookshelf systems that have been marketed. This type infinite baffle enclosure has the advantage of being relatively small, while maintaining good bass response. **Figure 7** illustrates how, instead of completely absorbing the rear wave, the entrapped air within the enclosure has an acoustic elasticity which acts like a spring against the loudspeaker diaphragm. By using a loudspeaker with a high compliance-low resonant cone assembly, the overall frequency of system resonance is held extremely low for the size enclosure used.

The advantages to acoustic suspension are enclosure size, smoothness of low frequency response, and a rather gradual roll-off after system resonance. The compromise of this type system is lower overall efficiency, and greater cone excursion requirements to produce the same sound pressure level—when compared to some other types of enclosures. Today, the availability of quality amplifier power at a reasonable cost in dollars per watt, more than ever, permits use of this principle for outstanding latitude in high performance designs.

### Bass Reflex Enclosures

The basic change from infinite baffle type enclosures to bass reflex is the handling of the rear wave from the loudspeaker. Instead of absorbing or dissipating the rear wave, the bass reflex lets the rear wave join the front wave. The advantage to this concept is that the rear wave can reinforce the front wave, achieving greater overall sound amplitude with low cone excursion. The bass reflex design, coupled with Altec's high efficiency type transducers, gives the user a very high efficiency system. The return is high dynamic range, and sound level capability, with minimum power requirements.

The key to good reflex performance is how the rear wave is controlled in joining the front wave. This wave joining is handled through a hole cut in the loudspeaker mounting baffle as in **Figure 8**. This hole is called the port. The port allows the energy from the rear wave to reinforce the front wave, extending the low frequency response.

When a hole is cut into the mounting baffle, there is a volume of air which "sits" in the port opening. This volume of air being equal to the square inch area of the opening multiplied by the depth of the port. The rear wave inside the enclosure pushes against this air, which then acts like a membrane of air to set in motion the air in front of the port. The front air, acted upon by the port air, causes a phase reversal—thus a common name to this type enclosure being phase inverter. This provides nearly the same phase condition at the front of the cone and the front air, which results in greater output at the frequency to which the port is tuned.

The control of the rear wave is handled through the size of the port and its depth. This variable port size is adjusted for its performance depending upon the system resonance, which is greatly dependent upon the internal volume of the enclosure and the characteristics of the particular transducer.

Basically, the larger the enclosure—the larger the port, and, conversely, the smaller the enclosure—the smaller the port. As the enclosure size reduces, and with it the port size, one can reach a point when the port becomes too small to be properly effective. This introduces the use of the ducted port.

The air entrapped in the port was described as the controlling membrane for the proper joining of the two wave forms. If we were to build a tunnel around the port, as in **Figure 9, 10**—extending from the loudspeaker mounting baffle back into the enclosure, we would have more air entrapped in the port. Thus, for a given size port opening in the baffle, we can change the port size by controlling the tunnel or duct length.

The use of a tunnel or duct enables the application of a smaller enclosure, for a given transducer, than ordinarily possible for good low frequency response. The application chart later in the publication covers the areas where regular and ducted ports are recommended with Altec transducers.

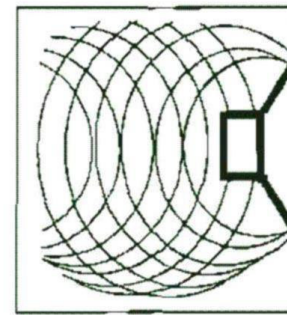

Figure 7

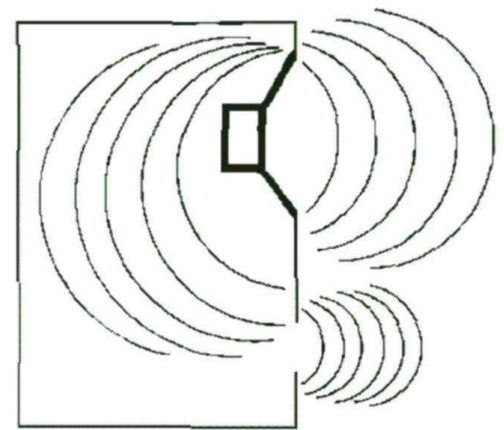

Figure 8

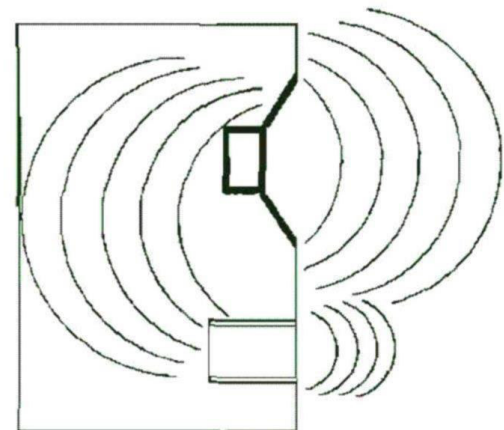

Figure 9

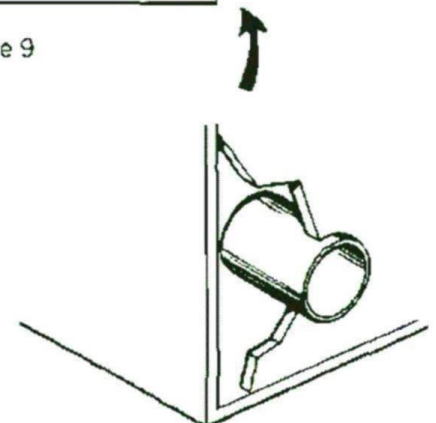

Figure 10

...pot pourri...



*© beim Hersteller  
Archie Michael-Otto*

### Low Frequency Horns

The low frequency horn is the most efficient method to couple the loudspeaker to the air. The horn enclosure, however, requires more physical space than any other type, and is extremely complex for home construction techniques. Low frequency capability in the horn enclosure is directly related to enclosure size. Some available systems utilize the walls of listening room as an aid to low frequency extension, but, even so enclosure size remains large. While some of the Altec low frequency loudspeakers are adaptable to horn use, we do not recommend, nor are we able to provide, predictable data on home horn construction.

**Karlson, Acoustic Labryinth, Resonant Folded Tube, Horn Loaded Port, Split Bent Horn, Drone Cone/Passive Radiator, Omnidirectional Diffuser...** Many approaches to sound reproduction are available. It is our desire to provide those recommendations which will insure

excellent and predictable results. The variables are really too great to cover all, and so we pass by these concepts.

### Combination Enclosures

The combination of two concepts in one enclosure is not usual, but Altec has long proven the value of one approach in its world famous "Voice of the Theatre" A-7 system. This approach uses a front-loaded low frequency horn in combination with bass reflex augmentation of the very low frequencies. This system uses a precise compression-type driver for reproduction of mid and high frequencies, which is mounted to cast aluminum sectoral horn. The A-7 system exhibits excellent phase relationship at the crossover frequency, and has exceptional efficiency and projection.

The front-loaded horn portion of the A-7 cabinet increases the efficiency of the low frequency loudspeaker in the range of 120 Hz upward to crossover. The bass

reflex portion of the cabinet is designed to augment those bass frequencies below the frequencies of the horn cut-off

For the enthusiast who has application for sound reinforcement, in addition to home reproduction requirements, the time-proven A-7 cabinet and system is ideal. For music reproduction use only, we would recommend one of our home "Voice of the Theatre" designs for more effective low frequency response.

The most frequent question asked Altec, concerning this system, is the difference between mounting the high frequency horn/driver on top of the enclosure, or inside the inverted cabinet. The basic on-axis response will not be effected either way. Internal mounting does reduce somewhat the overall horizontal dispersion. The correct answer then depends primarily on the importance of the wide off-axis response in your application.

# PORT TUNING PAPER

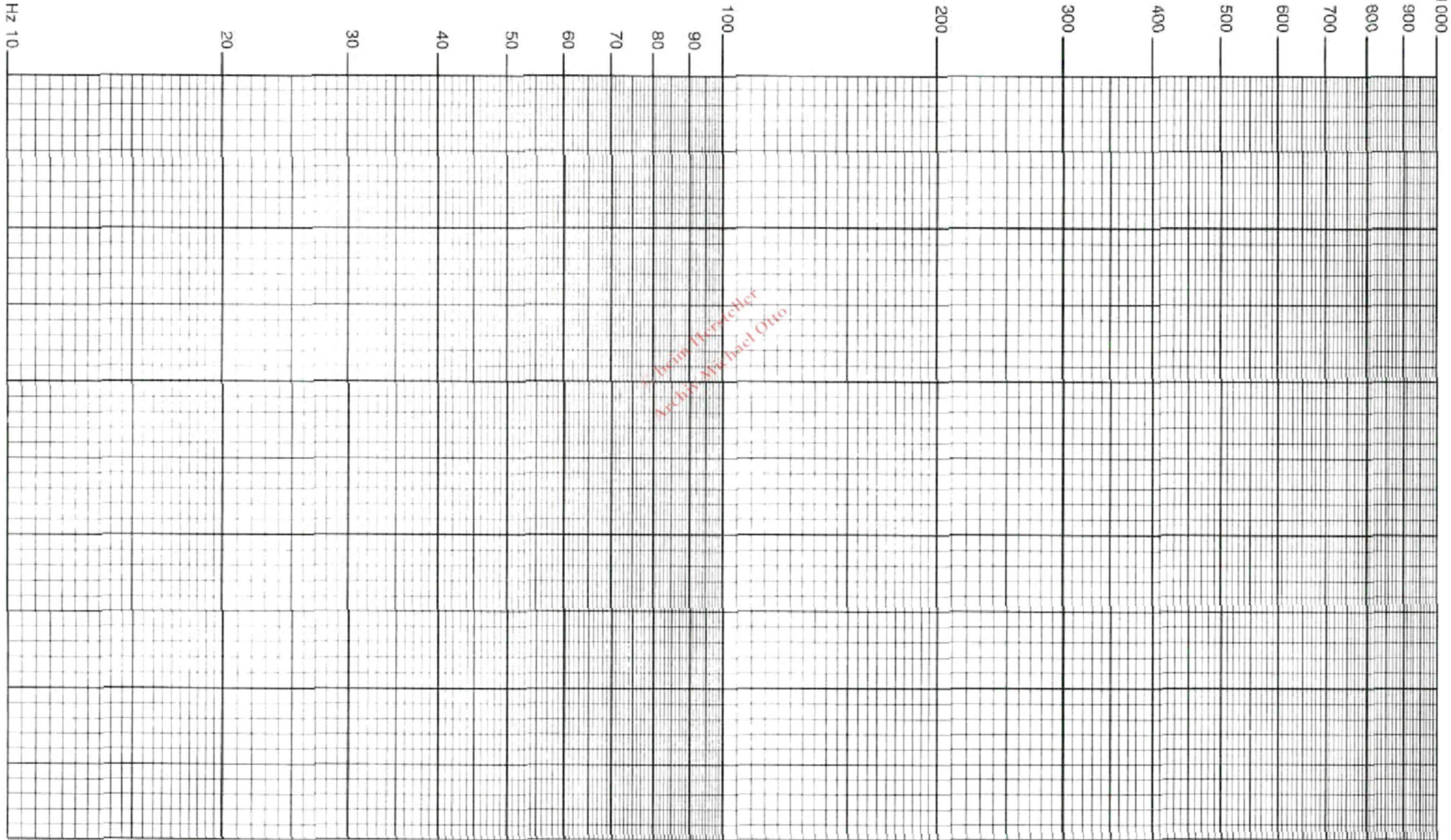

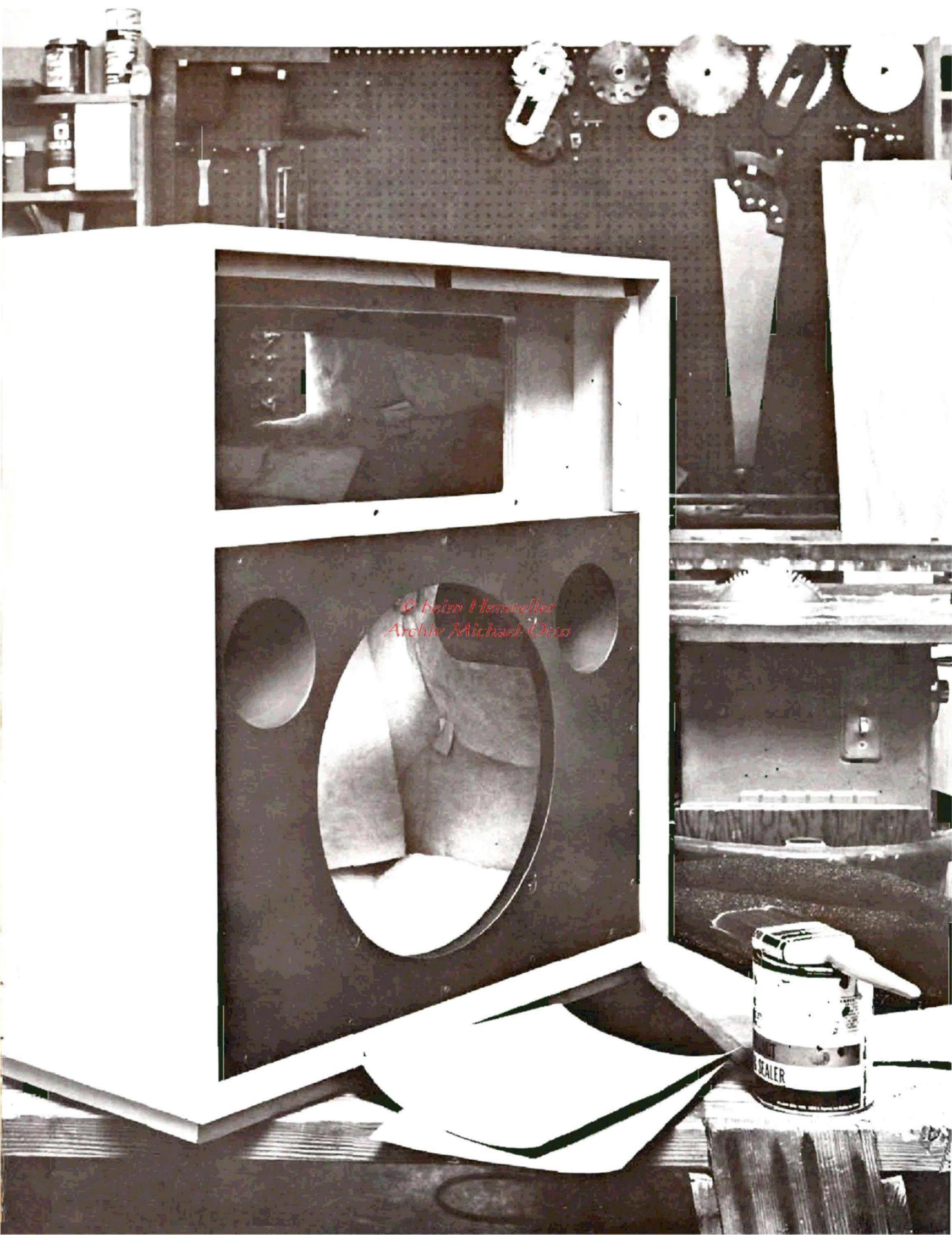

*© beim Hersteller  
Archiv Michael-Otto*

SEALER

## ALTEC RECOMMENDS

The recommendation of a single system to serve all needs is not practical. Altec's full and complete line of quality transducers will enable you to make a selection based on your space and cost considerations. The purpose of this section is to help in those decisions, based on our application experience.

If one is to select and use a two-way system at the start of the project, Altec offers a 12-inch and a 15-inch high efficiency low frequency woofer. The enclosure size recommendations would be a bass reflex of 2.5 to 10 cubic feet for the 12-inch, and 4.5 to 12 cubic feet for the 15-inch loudspeaker. For the ultimate in sound accuracy and output, the Altec "Voice of the Theatre" high frequency systems would be the proper match.

The Altec "Voice of the Theatre" high frequency systems are very similar to each other in performance, but with some subtle differences. The 800 Hz system offers greater latitude to enclosure design concepts, with its more shallow depth and overall reduced size. The 500 Hz system offers ideal midrange reproduction in the important presence range; also approximately 2 dB greater overall output. Either unit will deliver comparable high frequency reproduction.

For simplicity, and ease of construction, you could consider one of the two Duplex, or coaxial-type Altec loudspeakers. Basically, the 12-inch coaxial is our 12-inch high efficiency, low frequency woofer with a small, 3000 series, compression high frequency tweeter mounted concentrically in the center. The 15-inch unit uses our high efficiency, low frequency woofer with a "Voice of the Theatre" compression high frequency driver mounted concentrically on the same frame. The 15-inch Duplex type speaker differs from the regular "Voice of the Theatre" by using a higher crossover frequency and much shorter horn assembly. It is with great pride and care that Altec builds all its loudspeakers, but the famous 604 Duplex is special at Altec. This

single loudspeaker is used for more studio playback systems and monitors than any other single system. We have included, in the section of enclosure plans, a design for the 604 Duplex of older—but time-proven vintage—as well as newer enclosure designs. The single point-source sound, the ease of construction and mounting, and the high efficiency of the Duplex line give strong reasons for consideration to this approach.

The enclosure recommendations for the Duplex line would be the same as for the high efficiency, low frequency woofers. From 2.5 to 10 cubic feet for the 12-inch units, and from 4.5 to 12 cubic feet for the 15-inch units. These would all be bass reflex type.

The most recent Altec floor model designs have been in the area of the moderate size enclosure of from 5.0 to 8.0 cubic feet. The concept was to obtain excellent bass response from an enclosure of about one-half to two-thirds the size of comparable bass reflex units.

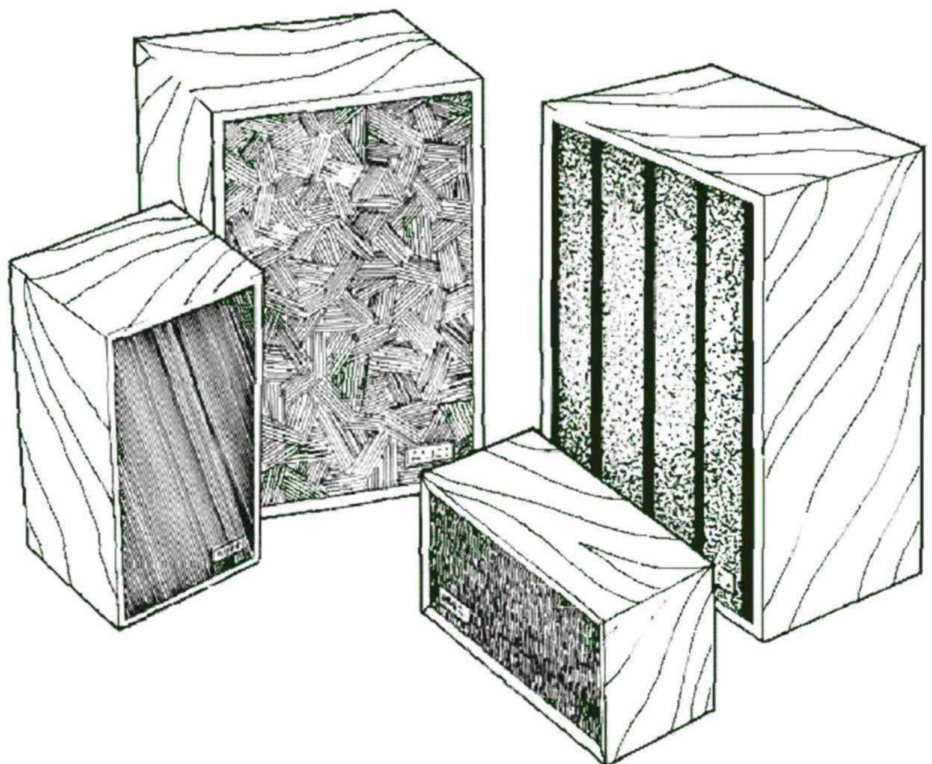

## ALTEC RECOMMENDS

MODEL	EFFECTIVE PISTON AREA	FREE-AIR RESONANT FREQUENCY (HERTZ)	OVERALL DIMENSIONS	MOUNTING HOLE DIAMETER		BOLT CIRCLE DIAMETER	ENCLOSURE SIZE PARAMETERS (CUBIC FEET)				
				Front Mount	Rear Mount		A INFINITE BAFFLE	B DUCTED PORT BASS REFLEX	C REGULAR PORT BASS REFLEX	D INFINITE BAFFLE	RECOM-MENDED OPTIMUM
405A	10.3 sq. in.	95	4 $\frac{1}{8}$ " x 2 $\frac{1}{8}$ "	14 $\frac{3}{32}$ "	14 $\frac{5}{32}$ "	4 $\frac{1}{8}$ "	> .25	> .3		< 1.0	.3B
601-8D	82 sq. in.	39	12 $\frac{1}{4}$ " x 5 $\frac{3}{4}$ "	11 $\frac{1}{8}$ "	11 $\frac{1}{8}$ "	11 $\frac{1}{8}$ "	>2.5	<3.5	>3.5	<10.0	3.5C
414-8B	82 sq. in.	30	12 $\frac{1}{4}$ " x 5 $\frac{1}{4}$ "	11 $\frac{1}{8}$ "	11 $\frac{1}{8}$ "	11 $\frac{1}{8}$ "	>2.5	<3.5	>3.5	<10.0	3.5C
604E/8G	133 sq. in.	25	15 $\frac{1}{8}$ " x 11 $\frac{1}{8}$ "	—	13 $\frac{3}{4}$ "	14 $\frac{1}{8}$ "	>4.5	<6.0	>6.0	<12.0	9.0C
416-8B	133 sq. in.	25	15 $\frac{1}{8}$ " x 7 $\frac{1}{8}$ "	—	13 $\frac{3}{4}$ "	14 $\frac{1}{8}$ "	>4.5	<6.0	>6.0	<12.0	7.5C
411-8A	133 sq. in.	18	15 $\frac{1}{8}$ " x 5 $\frac{1}{8}$ "	14 $\frac{1}{8}$ "	13 $\frac{3}{4}$ "	14 $\frac{1}{8}$ "	>4.0			< 8.0	5.0D

\*Use mounting baffle no greater than 1/2 inch.

## COMPONENT MATCHING

HIGH FREQUENCY SYSTEM — CONSISTING OF:			TO GO WITH LOW FREQUENCY WOOFER <sup>1</sup> /OR EXTENDED RANGE	
HORN	DIVIDING NETWORK	AND DRIVER	STANDARD	WITH 30904 ATTENUATOR/EQUALIZER NETWORK
811B	N801-8D	Recommended 806-8A	419-8B	411-8A
		Alternate 802-8D	414-8A	
			420A	
			416-8A	
<i>© beim Hersteller Archiv Michael-Otto</i>				
511B	N501-8A	Recommended 802-8D	419-8B	411-8A
		Alternate 806-8A	414-8A	
			420A	
			416-8A	

<sup>1</sup>Where two low frequency woofers are used in one system, 16 ohm loudspeakers should be special ordered through your Altec Dealer.

## ...side dish and recipe...

This is achieved with the new Altec 411 Series, 15-inch acoustic suspension woofer. This low frequency loudspeaker was specifically engineered for acoustic suspension, infinite baffle application. The latitude available to the user is excellent, with enclosure recommendations to be greater than 4.0 cubic feet and less than 8.0 cubic feet. A cabinet of less than the 4.0 cubic feet can be used, but the upward shift of system resonance would normally be higher than desired—basically not giving the 411 the opportunity to operate at its best performance. A cabinet of more than 8.0 cubic feet will begin to lower system resonance to the point of unloading the diaphragm properly. The free-air resonance of the 411 loudspeaker is an extremely low 18 Hz and power handling capacity is very high. The recommended enclosure is a nominal 5.0 cubic feet

To obtain the extremely fine performance parameters of the 411 series, Altec gave up approximately 6 dB in output—compared to the high efficiency units. With today's values in amplifier power, compared to a few years ago, this compromise is well within the reach of every audio user. Further overall system performance is improved through the use of system equalization. When the 411 series low frequency woofer is matched to a "Voice of the Theatre" high frequency system, there is a mismatch in system efficiency. In Altec factory-built systems, we use an attenuator/equalizer network which shelves the efficiency of the "Voice of the Theatre" high frequency system to match the efficiency of the 411 woofer. Further it provides shaped shelving for the flattest possible

overall response. These attenuator/equalizer networks are available for the home builder, and are listed on Altec price lists.

### Altec Recommends...

Altec's position throughout this publication has been to recommend home floor model construction of enclosures, and to stay with factory enclosures and systems for bookshelf and small systems. While this is basically the case, the exceptions must be stated.

The Altec 5-inch frame Model 405 mini-loudspeaker is an exceptional extended range performer. Widely used in quality public address and background music systems, it makes a fine music performer in small cabinets or automobile doors. The speaker can be adapted to either infinite baffle or bass reflex approach. In extremely small infinite baffles, it would be expected the low bass response would be somewhat diminished. For bass reflex cabinets, an enclosure of from 0.3 to 0.5 cubic feet works well.

This high efficiency transducer is an exceptional performer, and is relatively non-critical as to its enclosure. While Altec has not engineered a specific enclosure for factory-built marketing, the parameters outlined will insure proper performance in your application.

### TUNING THE BASS REFLEX PORT

The "correct" port size for a given enclosure of bass reflex design is dependent on a number of inter-related factors, not the least of which could well be an engineering concept of a partic-

ular design engineer. Altec's concept with this publication is to present a viable method to tune any transducer to any enclosure. Variables to this method—to achieve specific results—will also be discussed. The tuning portion of cabinet construction is presented at this part of the publication; however, the tuning would take place—in practice—after the cabinet is constructed and the transducers are mounted.

Presuming distortion to be an undesirable factor, the following method will tune the system with a minimum subjective distortion. This allows the rear-cone energy to couple with, and smoothly augment, the front-cone energy. To begin, you should be sure that the enclosure is air tight and without any leaks. From this standpoint, both an infinite baffle and the bass reflex start in a similar manner—that of being a rigid, air tight box.

The following equipment would be used in the port tuning: Sine-wave audio generator; a voltmeter; a resistor rated from 500 to 1000 ohms at 2 to 5 watts and some graph paper. The speaker is connected to the amplifier or receiver in the normal manner, but with one exception—the resistor is put in series with the loudspeaker wiring. The audio generator output would be plugged into the auxiliary input of the control section, and the voltmeter is connected across the speaker to measure the voltage variation between the amplifier and loudspeaker as in Figure 11. If you do not have this equipment readily available, talk to your local dealer about renting same for a weekend—or perhaps have his service facility perform the tuning to one cabinet,

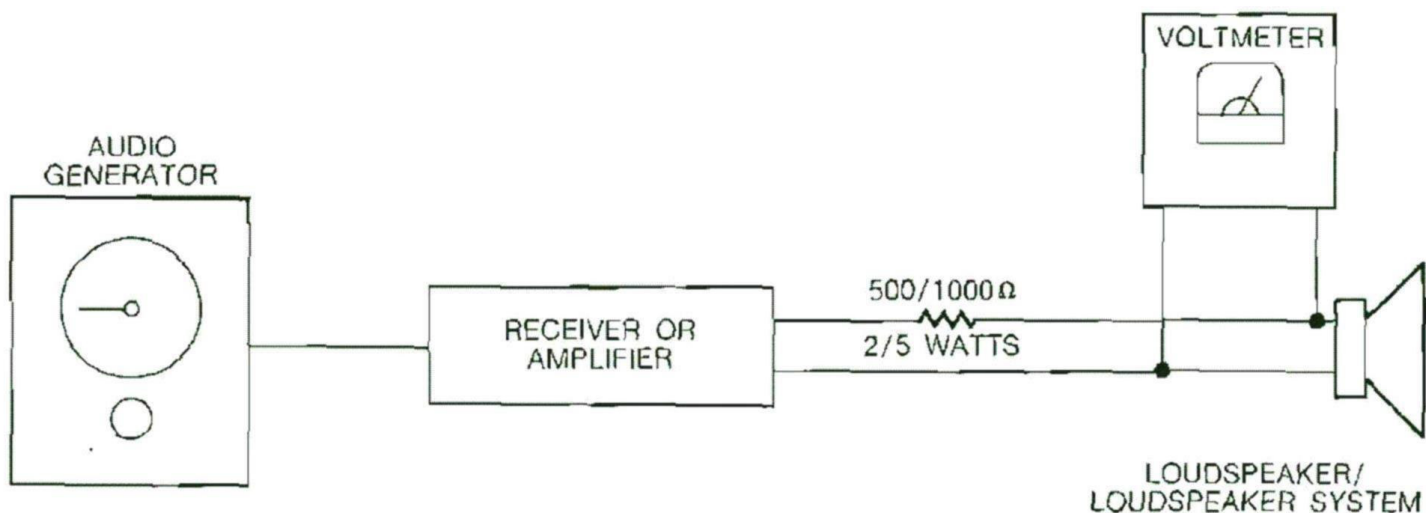

Figure 11

## ...mountain climbing to roller coasters...

which can then be duplicated as required. It should be pointed out that these measurements can be made at low volume level, as the plot of the impedance curve is not a function of loudness.

The graph plot of the impedance curve is important to tuning only in the range of the lower frequencies. The audio generator is swept from about 250 Hz downward to about 10 Hz. The variation of voltage potential is plotted on the graph paper as a function of frequency.

The sealed, air tight box will exhibit a plot similar to the curve in **Figure 12A**. In **Figure 12B** we represent a system which is not sealed properly, and has a small air leak. If this curve is found, you should recheck the enclosure to locate the leak and seal prior to serious plotting. A loudspeaker does not know the difference between such a leak and a port, and all leaks should be sealed prior to porting.

As an actual port-opening is made in the enclosure, the impedance curve will change. Within a relatively few hertz of the system resonance, as exhibited in the infinite baffle condition, there will be an impedance trough in the bass reflex curve. There will be two new resonant peaks, appearing approximately one octave on each side of the old single peak. These new peaks will be somewhat less in height, compared to the single infinite baffle peak—and the odds are that the two peaks will not be of equal height.

**Figure 13A** shows an impedance curve which would indicate a port that is too small. **Figure 13B** exhibits the opposite condition, when the port is too large. The recommended curve to seek, would be as in **Figure 13C**—with the two impedance peaks of equal height and amplitude.

When the selected enclosure size includes the recommendation of a ducted port, it may be tuned in the same manner as a regular port. This is done by varying the length of the duct and/or varying the area of the opening. For a given size opening, the port will be apparently smaller as the tunnel or duct is lengthened. Because the "trial and error" period of obtaining proper impedance peak matching is longer and more involved with ducts, as compared to a regular port, Altec recommends using rigid cardboard mailing or architectural tubes for ducts. These tubes are inexpensive, and may be easily cut to various

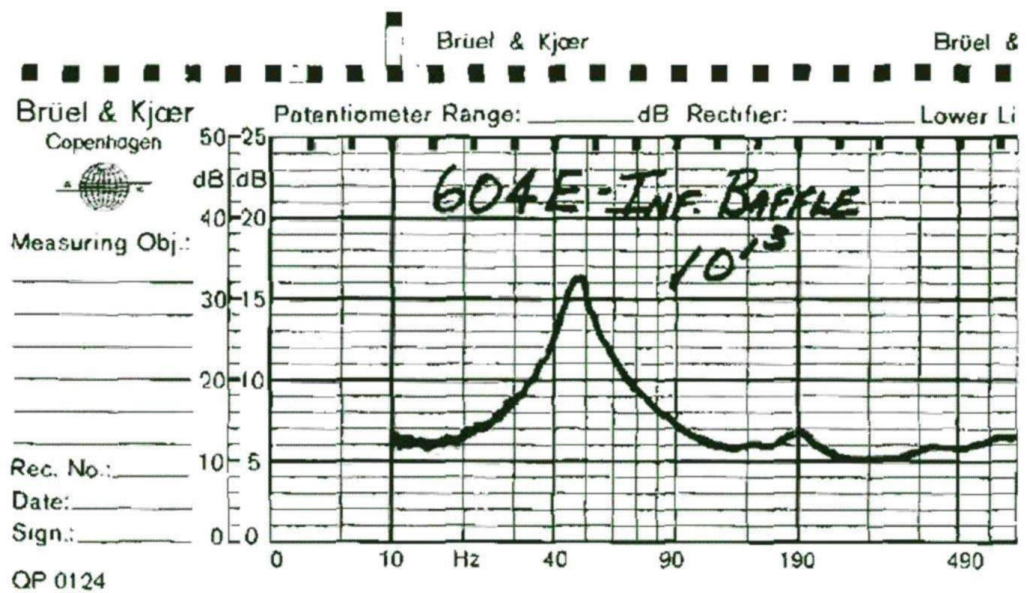

A

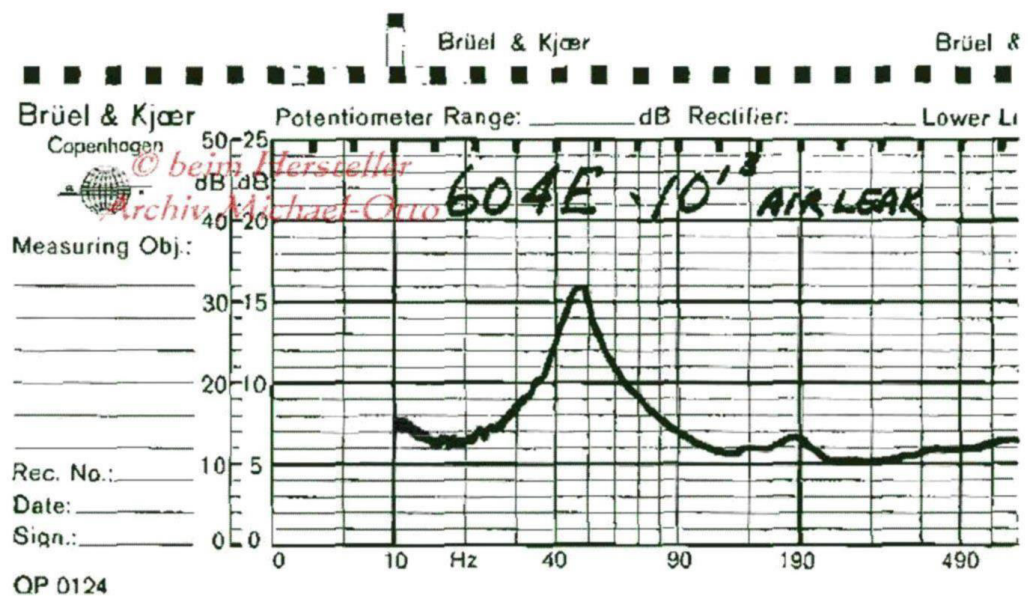

B

Figure 12

lengths, as you adjust the depth for the proper impedance curve.

The cutout in the speaker mounting baffle is a regular circular hole, the size of the outside diameter of the tube. After the proper tube length is determined, the duct can be permanently mounted by gluing and nailing to place in the cutout.

There are times when the design goals have been or are different in reflex porting from what we have described. This may be due to the particular matching of a specific enclosure to a given trans-

ducer—or the particular bass frequencies that are wished to be emphasized. These other instances might bring pleasant results, but may be at the cost of some performance factor. The impedance peak matching method is both predictable and reliable.

It will be necessary to "tune" only one enclosure. The tight manufacturing tolerances of Altec transducers are precise, and insure uniformity one to another. A duplicate enclosure, for a duplicate transducer, will yield identical results.

...the what wire to which?...

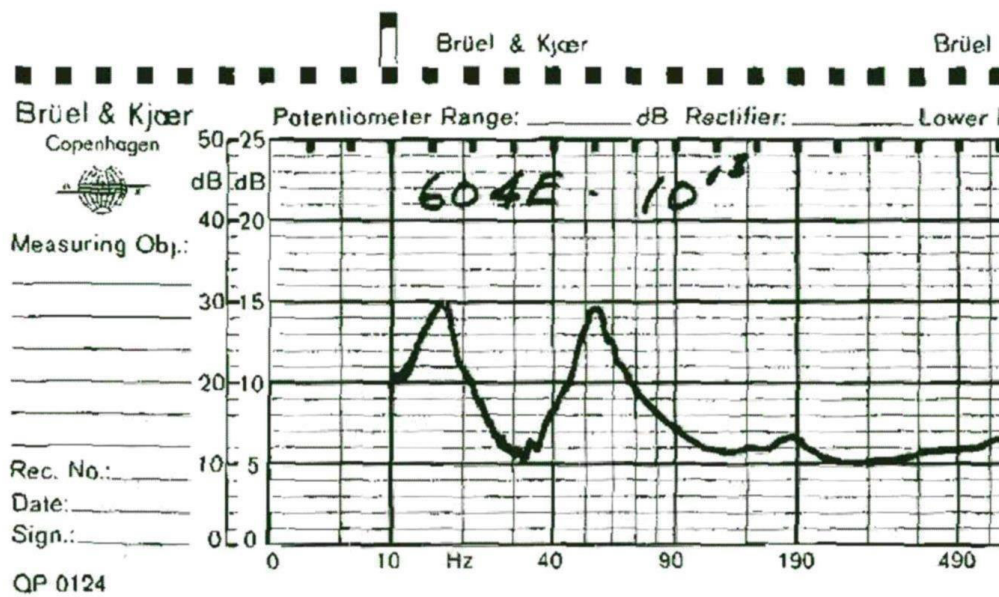
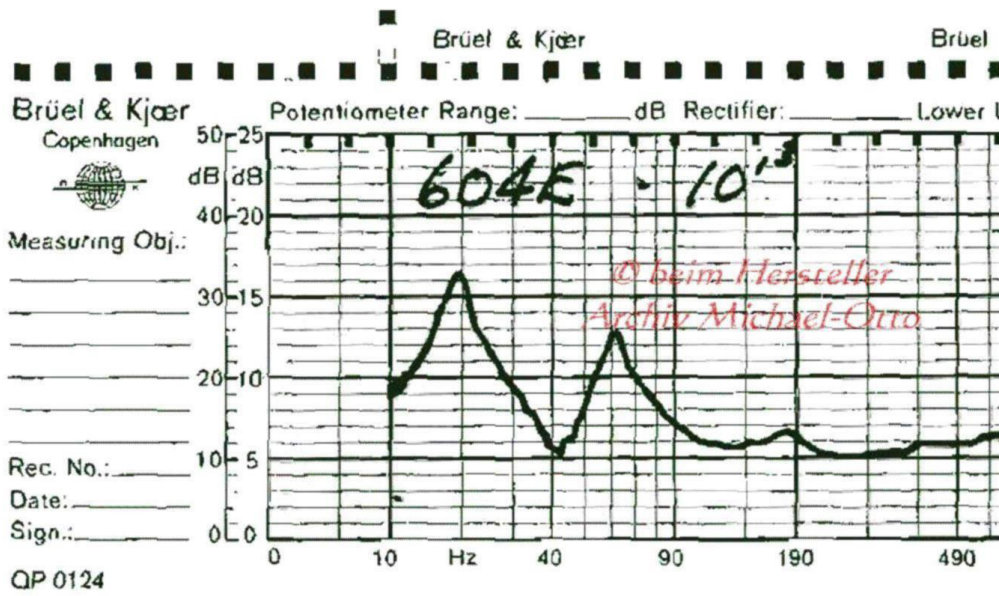
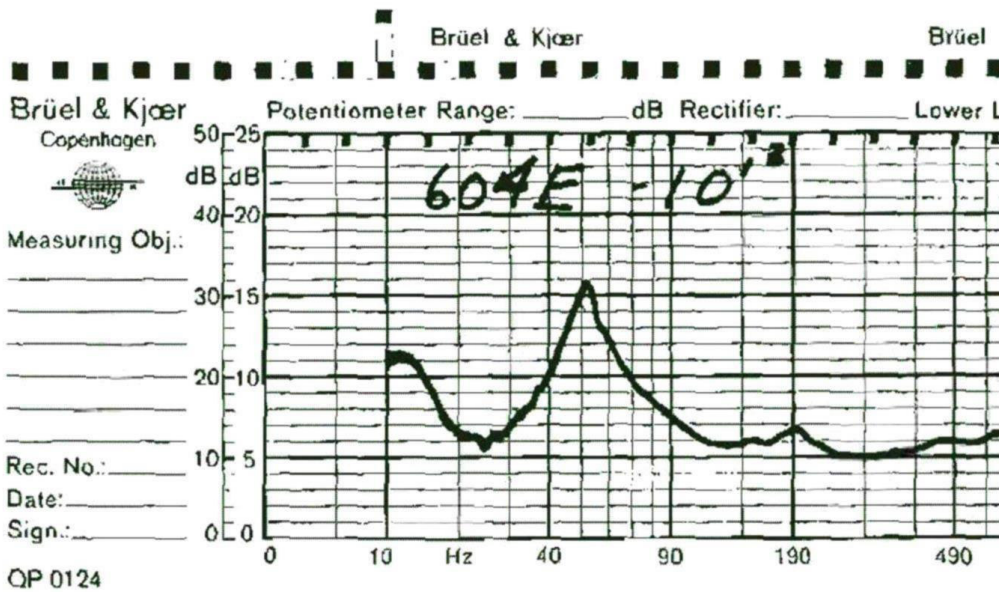

### SPECIAL CONSIDERATIONS FOR ALTEC "VOICE OF THE THEATRE" HIGH FREQUENCY SYSTEMS

Enclosures designed for Altec "Voice of the Theatre" high frequency systems require some special design thoughts, with respect to acoustic phasing. A two-way loudspeaker system needs to be properly phased, from an acoustic standpoint, to obtain smooth response in the crossover region. This acoustic phasing refers to the phase relationship between the horn-loaded high frequency driver and the low frequency loudspeaker. To achieve proper acoustical phasing, the electrical phase relationship may have to be adjusted.

Altec electrical coding establishes that the positive terminal is that terminal which, when a positive voltage is applied, creates a directional movement of the diaphragm away from the magnet assembly. Because the magnet structures of Altec's low frequency loudspeakers are mounted behind the diaphragm and magnet structures of "Voice of the Theatre" high frequency drivers are mounted in front of the diaphragm, a positive voltage to the positive terminal will cause a difference in directional relationship between the two diaphragms.

In the Altec A-7 "Voice of the Theatre" systems, the leads to the transducers are connected as shown in Figure 14A. Current Altec systems such as the 873, 878 and 846U and B, use the stepped horn/driver plane relationship of Figure 14B. This is the recommended design for optimum performance. Where the enclosure cannot be adapted to the "stepped" design, Figure 14C is the preferred alternate in mounting and electrical phase. This system wiring creates the correct acoustical in-phase condition for smooth transition at crossover.

The "stepped" design approach can be achieved with the horn/driver mounted inside the low frequency enclosure, as with the Altec 846U and B, and 878 cabinet designs. An alternative would be to mount the high frequency system on top of the low frequency enclosure, and then enclose the entire combination in a decorative, finished shell. This is the approach of the Altec 873 design.

Figure 13

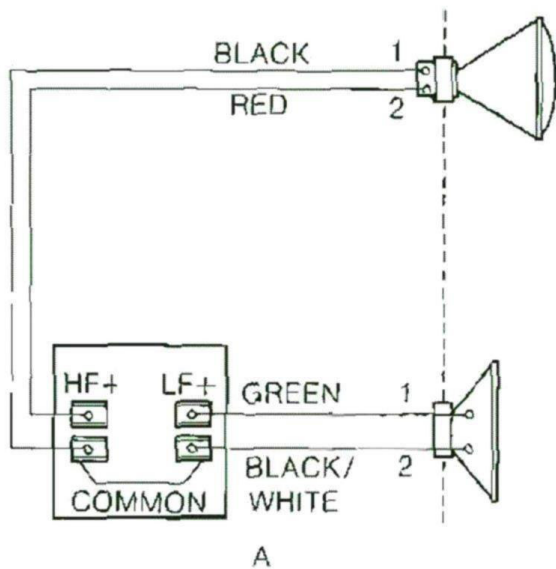

Voice coils in same vertical plane

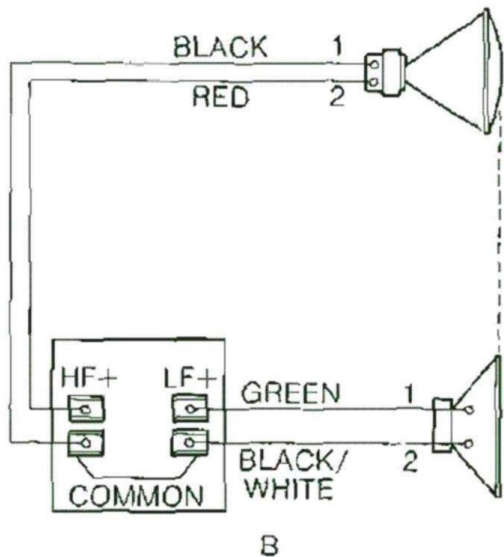

Front of horn and LF loudspeaker in same vertical plane

*© beim Hersteller  
Archiv Michael-Otto*

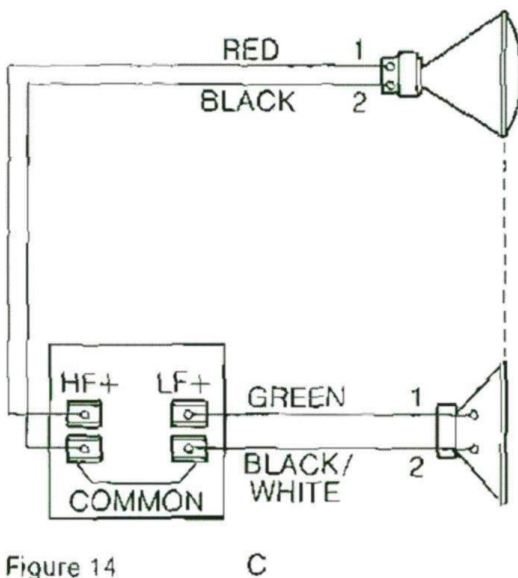

Mounting flanges of HF horn and LF loudspeaker in same vertical plane

Figure 14 C

**Note:** On models which use color coded rather than numbered terminals, the red terminal is equivalent to terminal 2 on high frequency units, and terminal 1 on low frequency units.

## SELECTION OF MATERIALS FOR THE ENCLOSURE

The foremost thought to the enclosure material generally concerns the cabinet shell. Most quality loudspeaker systems use high density particle or flake board, which is covered with veneer. There are several good reasons for this choice, only one being cost. Particle board is extremely rigid and dense. This reduces the chance of setting up cabinet panel resonances, and also is almost impervious to warpage. The fact that particle board is the least expensive acceptable material is a bonus.

Second choice would be quality plywood, of either the multiple density overlay type or good lumber core. With either type, care should be exercised to see that the pieces selected are free of voids.

Some Altec factory-built enclosures use a combination of plywood and particle board. While particle board has greater rigidity and density, plywood offers greater shear strength. This latter feature is applicable to prevent possible shipping or handling damage to enclosures using some of the heavier transducers. Thus, it is not a bad idea to construct the speaker mounting panel from high quality plywood, and the rest of the cabinet from particle board.

The purchase of particle board sheets, where the veneer has already been applied, is difficult to find—compared to plywood. With either plywood or particle core, the care exercised in cutting, gluing and assembly would need to be high—to protect the veneer from becoming blemished or damaged. While this is the most popular method of home construction, strong consideration should be given to constructing the cabinet completely in an unfinished particle board and/or plywood. Veneer may then be purchased in either sheets or cloth backed rolls. The veneer of your choice may be then applied, after total construction, in a manner similar to a laminate—easing construction and perhaps hiding a goof or two in the enclosure assembly.

Solid hardwoods should only be considered in non-functional trim applications. This keeps warpage from being a problem and eliminates the variable density problems of hardwood.

The materials selected should be the standard 3/4-inch thickness. It would not normally warrant thicker enclosure walls, unless the cabinet were extremely large.

... to have and hold ...

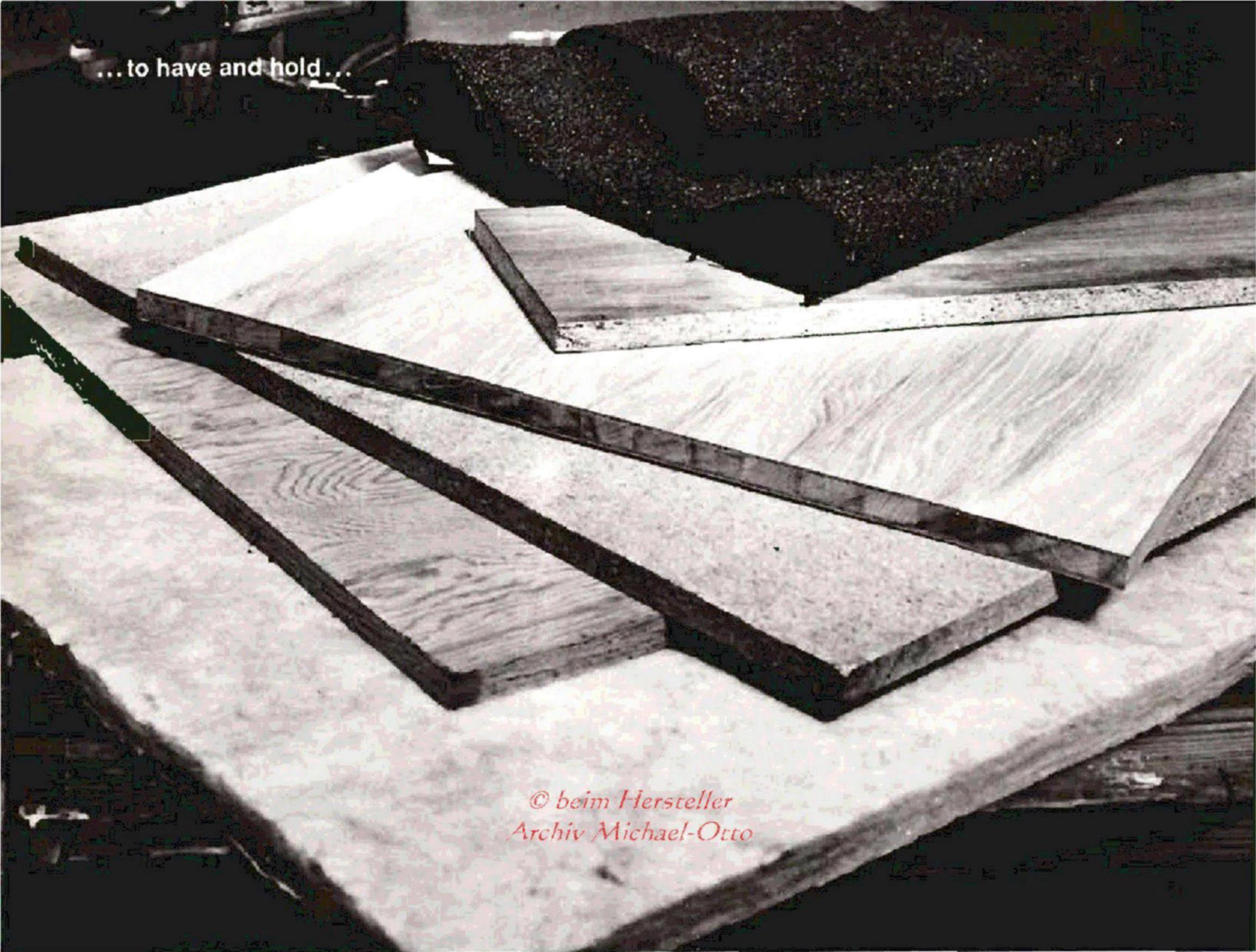

*© beim Hersteller  
Archiv Michael-Otto*

Any additional requirements to eliminate panel resonances, or such, can be handled with internal braces or stiffeners

All effort for clean, straight cuts is worthwhile, but standard cabinet tolerances should be understood. Altec factory-built cabinets are built to a dimensional tolerance of plus or minus 1/32-inch.

Most Altec loudspeakers include a mounting hardware kit of T-nuts and mounting bolts. While regular wood screws could physically hold some of the lighter weight transducers, the T-nut and bolt method is preferred. Tighten the bolts snugly and evenly, but do not cinch down. Extreme pressure might warp the loudspeaker frame beyond tolerance.

Locate and scribe circles as required for the loudspeaker mounting hole and mounting bolts. It would be suggested to make the mounting hole cut very slightly undersize, and use a wood rasp or file to finish to exact size. Remove all debris

from holes, edges, and the enclosure prior to finishing

In standard cabinet practice, several methods are available to make the joining corners—butt joint, standard mitre; lock-mitre; butt mitre; and on . . . There is no particular "right" type of joint, but selection should be made to insure good structural strength and freedom from air leaks. It is suggested that the addition of corner glue blocks will help in achieving the goals desired.

#### **Glues, Clamps, and Screws**

The glue surfaces adjacent to finish surfaces should be bonded with a product like white glue, which can be easily cleaned from a finish surface prior to actual finish material. Normal care should be exercised when using either pony clamps or elastic clamps to protect finish edges from abrasion or compression. This can be done with blocks or pads between the surfaces. All removable back or speaker mounting panels, that are held

in place by wood screws, should use an adequate number. We would recommend a minimum of one screw per 6 linear inches of span.

#### **Acoustic Damping Material**

The interior of the enclosure should have a partial or complete lining of acoustic damping material. Probably the most readily available satisfactory material is fiberglass. The Owens-Corning Fiberglas Corporation manufactures a type called Aerocore®, which is available in many lumber and building supply stores. Available in roll form, you need only buy the amount required by your cabinet.

In a bass reflex enclosure the purpose of the damping material is to help break up standing waves, as well as provide proper damping of the low frequency loudspeaker. Altec recommends that the back of the enclosure and any two adjacent sides be lined with the material.

®Registered Trade Name—  
Owens-Corning Fiberglas Corporation

## ...how to handle the cover-up...

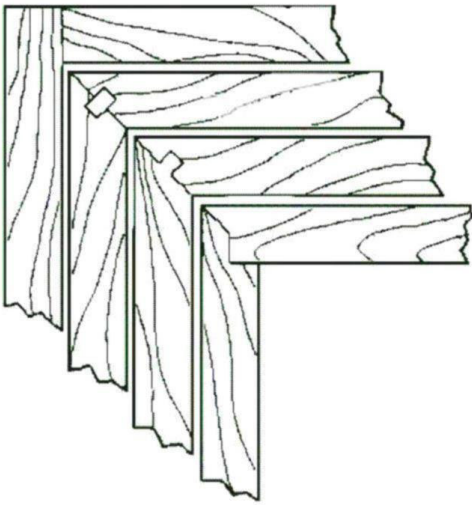

That would be either the top or bottom of the cabinet, one side, and the back. Normally, material 1½-inch to 2-inches thick will suffice.

The infinite baffle is supposed to absorb the entire rear wave of the loudspeaker, and so we line all interior walls except the speaker mounting baffle. The amount used, in thickness, is normally the same as in the bass reflex. An optional curtain of fiberglass can be hung from the cabinet interior if additional damping is needed.

The normal method to check speaker damping is simple, but is easiest if you start out with too little fiberglass. We recommend the battery test method to check for damping. Attach a short length of speaker wire to the loudspeaker terminals in the normal manner, and bring the loose end around to the front—where you can easily listen to the loudspeaker sound while testing. Hold one of the two speaker leads to either end of a standard 1.5 volt flashlight battery. Then touch the second lead to the other end of the battery and release. A properly damped loudspeaker will reproduce a clean "click" as contact is made and released.

The underdamped speaker will reproduce the battery contact as a "whomp" sound. Fiberglass may be added in a loose manner to the enclosure until the proper "click" is obtained, and then stapled into place according to the above practices relating to the specific type of enclosure.

The overdamped speaker is more difficult to observe. It is a matter of degrees that becomes familiar with one or two experi-

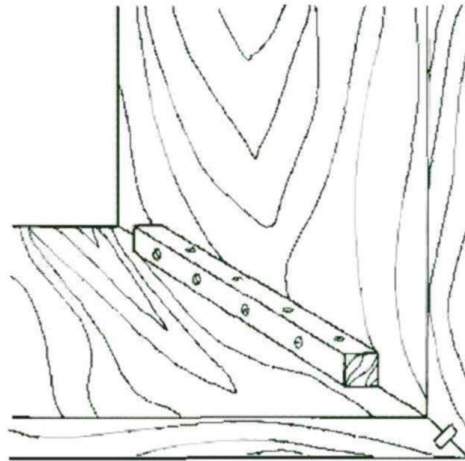

ments. Thus, the recommendation to start tests with too little, build up, and then go back down as required.

Some infinite baffle systems, particularly where high efficiency transducers are used in a cabinet too small for reflex porting, require more fiberglass than normal. The reason is to "fool" the loudspeaker into thinking it is in a larger enclosure. The info of glass is Use Archib Michael-Ohio, in this instance, to purposely overdamp the loudspeaker. We then use amplifier power to compensate for the slight loss in efficiency, compared to the same transducer in a larger reflex enclosure.

### Stiffeners

One of the most important factors to good home performance is the use of adequate stiffeners and braces. Because many types of braces do not lend themselves to production line techniques, some home systems, which have extra bracing, can actually outshine their factory counterparts.

Single enclosure panels of greater than 2 square feet can set up resonances, and should have internal stiffeners to reduce this potential problem. A 2 x 3 stiffener, set on edge, should be used to divide the panel into two smaller surfaces. The stiffener would be glued and screwed on the diagonal for maximum effectiveness as in **Figure 15**.

Maximum reduction of enclosure panel resonance can be created by internal bracing as in **Figure 16**, between the opposite panels in the enclosure. This can be done without exposure of wood screws by use of cleats; or, as an alternative, complete the veneering of the cabi-

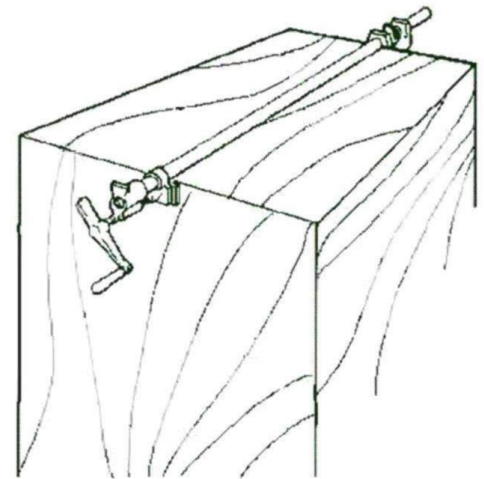

net as the last step to cover the wood screws used.

### Grille Considerations

Older designs by Altec, and other manufacturers, generally call for the grille assembly to be an integral part of the enclosure itself. Our later cabinets and our recommendation for your enclosure, are designed to make the grille panel a separate assembly. This will enable you to change the cloth over a period of time to suit decor, or solve problems of wear or dirt.

Grille cloths can be either fabric, such as with drapery, dress or upholstery material, or materials fabricated specifically for grille assemblies. The prime difference is that grille fabrics will either be made entirely or interwoven with saran or plastics. This feature will allow for dry heat, such as from a hair dryer, to return the cloth to a natural shape after it has been stretched from a bump or abuse. There is really no detrimental effects of straight cloth, compared to plastic fibers, as long as the overall requirement is met.

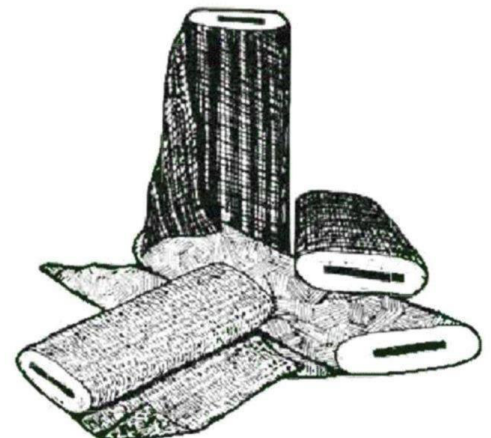

The prime consideration is the openness of the weave of the material selected. When raised to the light, you should be able to readily see through the cloth. Raise it to your lips, and gently blow—feeling free air passage through the cloth with your hand, you will know if the weave is too light or too thick.

A new and popular concept for factory-built systems is a grille assembly using Polycoustic Foam®. This material is an open cell foam that allows exceptional passage of high frequencies when mounted close to the transducer. This should not be confused with the closed cells foams that are often used in packaging and absorption applications. It is generally not practical to consider designing a home enclosure that would use a special foam grille. The foam is available only in large runs and large quantities. A design is firmed, hot wire tooling purchased and then one has the facility to make quantity production runs. The costs to do one or two grilles would be very prohibitive. Altec does make available, as a completed assembly on special order from your dealer, the grille assemblies from the completed factory-built systems. If your enclosure should be made to the exact size requirements of one of Altec's ready-made grilles, you might consider the foam approach

### Finish

The wood finish selected will undoubtedly be based on the end result you are seeking. At Altec, we use oil finishes for both their lasting beauty and ease of upkeep and maintenance. It is particularly recommended as a finish for someone starting into furniture construction. Your local hardware or building supply store will be helpful in achieving the desired result. The ornamentation of the cabinetry is generally left to the builder, so that it will meet the decor you desire.

### Speaker Wire

Almost any kind of wire can transmit the signal from the amplifier to the loudspeaker system. The question, however, is how well. The wire has resistance that will vary, depending upon its size and

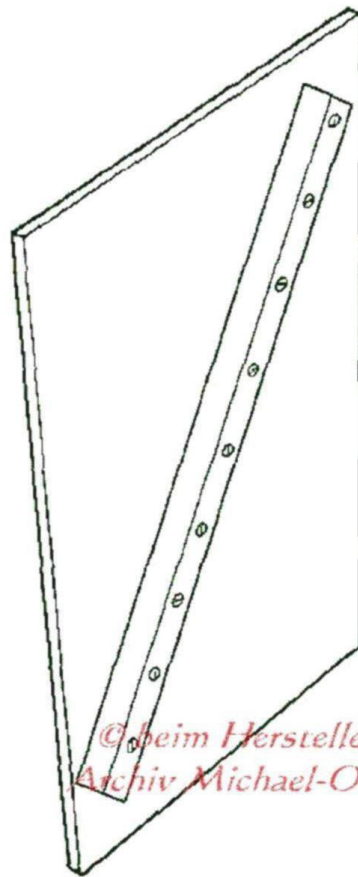

Figure 15

*©heim Hersteller  
Archiv Michael-Otto*

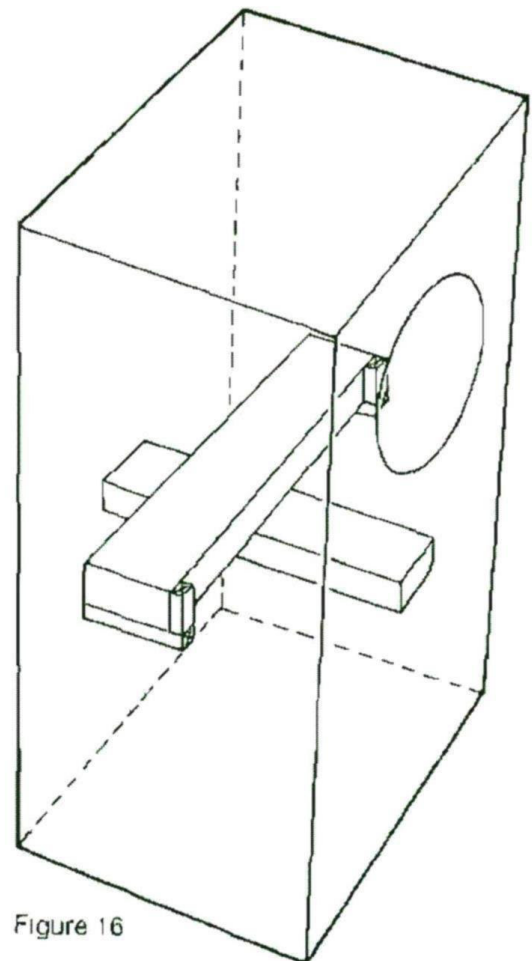
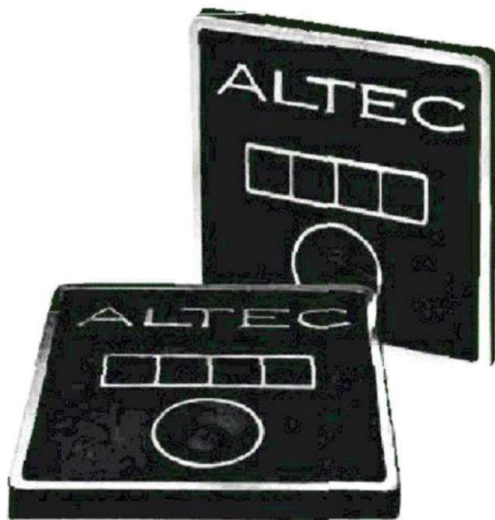

Figure 16

length. As the resistance increases, it does not change the effect of the loudspeaker performance—but rather, it changes the amount of power the amplifier is capable of delivering. An example might be a 30 watt amplifier, connected to a 4 ohm load with 24 gauge wire 20 feet long, capable of delivering only 20 watts to the loudspeaker—because 10 watts was being wasted in the resistance of the speaker leads.

Altec's recommendation for minimum wire size is standard 18 gauge zipcord. This is the same size and type as used in most lamp cords, radios and other light appliances. This type should prove adequate on installations of less than 30 feet in length. For runs of longer than 30 feet, 16 gauge or larger is recommended. (The smaller the gauge number the larger the wire.)

...ENJOY...



**Logo**

Altec has created a special die-cast metal logo for those consumers wishing to add a factory name-plate to their completed system. We know the construction effort of the enclosure was executed with pride, and we have tried to create for you a logo of equal pride. These may be ordered directly from the factory at a prepaid cost of \$3.00 a pair. We do ask, for our files, a snapshot of your completed system.

Make your check payable to:  
 ALTEC, SOUND PRODUCTS DIVISION—  
 and mail to:  
 ALTEC, SOUND PRODUCTS DIVISION  
 ATTENTION: HI FI MARKETING  
 1515 SOUTH MANCHESTER  
 ANAHEIM, CALIFORNIA 92803

**SUMMARY**

If you have access to a radial arm or table saw; can make a rigid, air light box; and have the inclination—you can make your own loudspeaker enclosure. And it has only taken 32 pages to prove it. It can be easy and fun. It can save 40 to 60 percent of the cost of a given factory-built system.

There is a pride and sense of accomplishment in building your own enclosure not found in many endeavors. There is the opportunity to create, rather than accept what is available.

Most important: When it is finished and completed, it is ready to deliver the dynamics available from today's spectacular recordings with accuracy and power. You will hear your sound as never before . . . Enjoy!

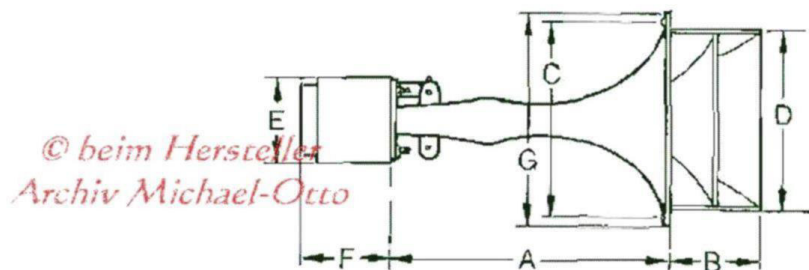

*© beim Hersteller  
 Archiv Michael-Otto*

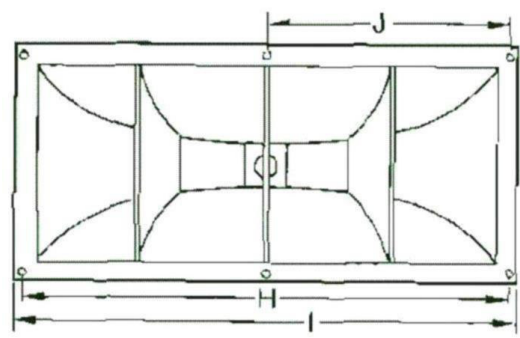

	811B	806-8A	511B	802-8D
<b>A</b>	10¼	—	13¼	—
<b>B</b>	3¼	—	4¼	—
<b>C</b>	8	—	9¾	—
<b>D</b>	6¼	—	9¼	—
<b>E</b>	—	4½	—	4½
<b>F</b>	—	3¼	—	3¼
<b>G</b>	8¾	—	10¾	—
<b>H</b>	17¼	—	22¾	—
<b>I</b>	18¾	—	23½	—
<b>J</b>	8¾	—	11¾	—

**OUTER DIMENSIONAL DRAWINGS  
FOR SUGGESTED ENCLOSURES  
AND RECOMMENDED LOUDSPEAKERS**

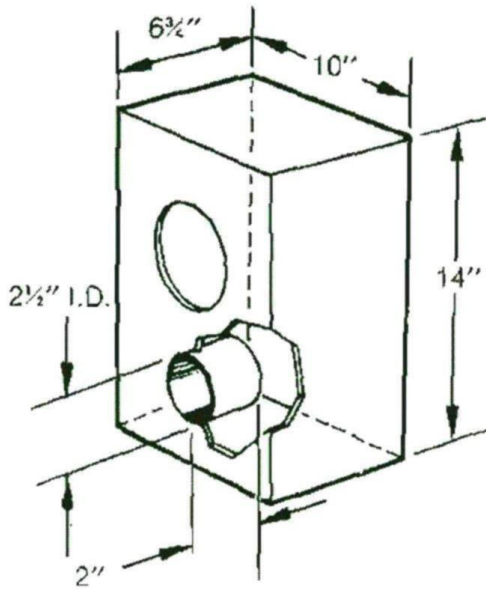

**405A Mini loudspeaker**

*© beim Hersteller  
Archiv Michael-Otto*

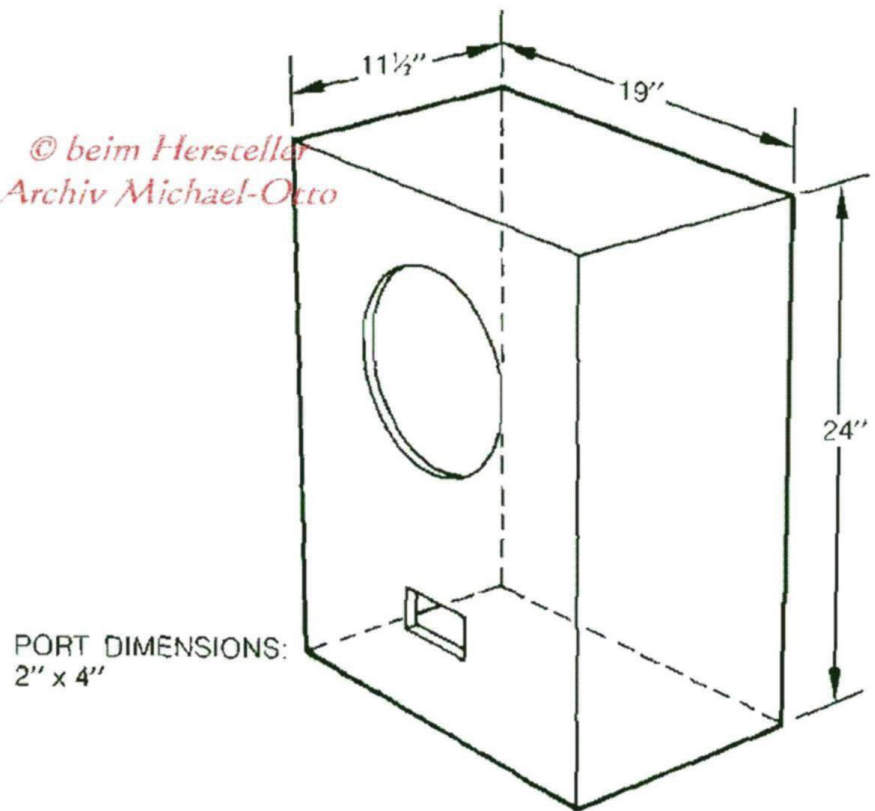

**12-Inch Duplex.**

**OUTER DIMENSIONAL DRAWINGS  
FOR SUGGESTED ENCLOSURES  
AND RECOMMENDED LOUDSPEAKERS**

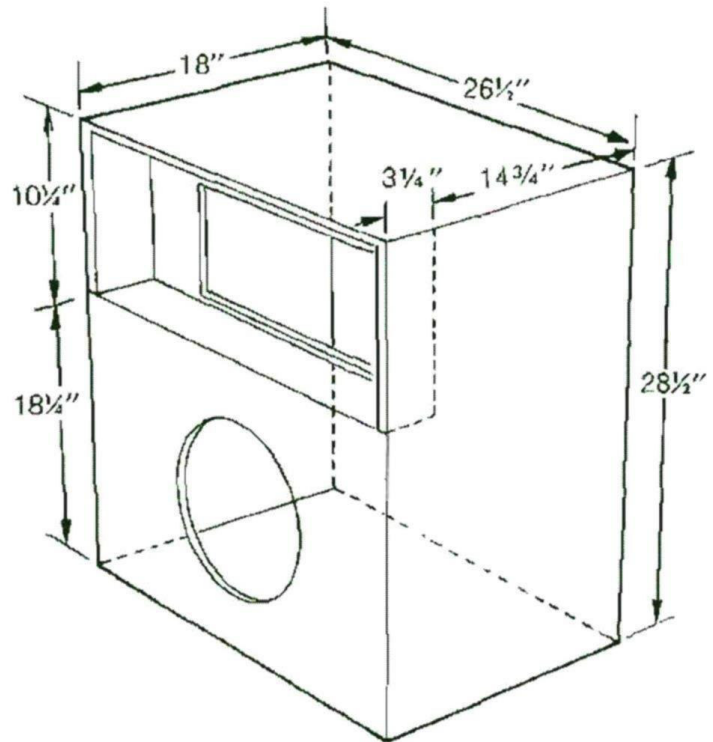

800 Hz, medium efficiency, 411 type, home "VOICE OF THE THEATRE" system. HF horn/driver mounted inside LF woofer enclosure.

*© beim F...  
Archiv Michael-Otto*

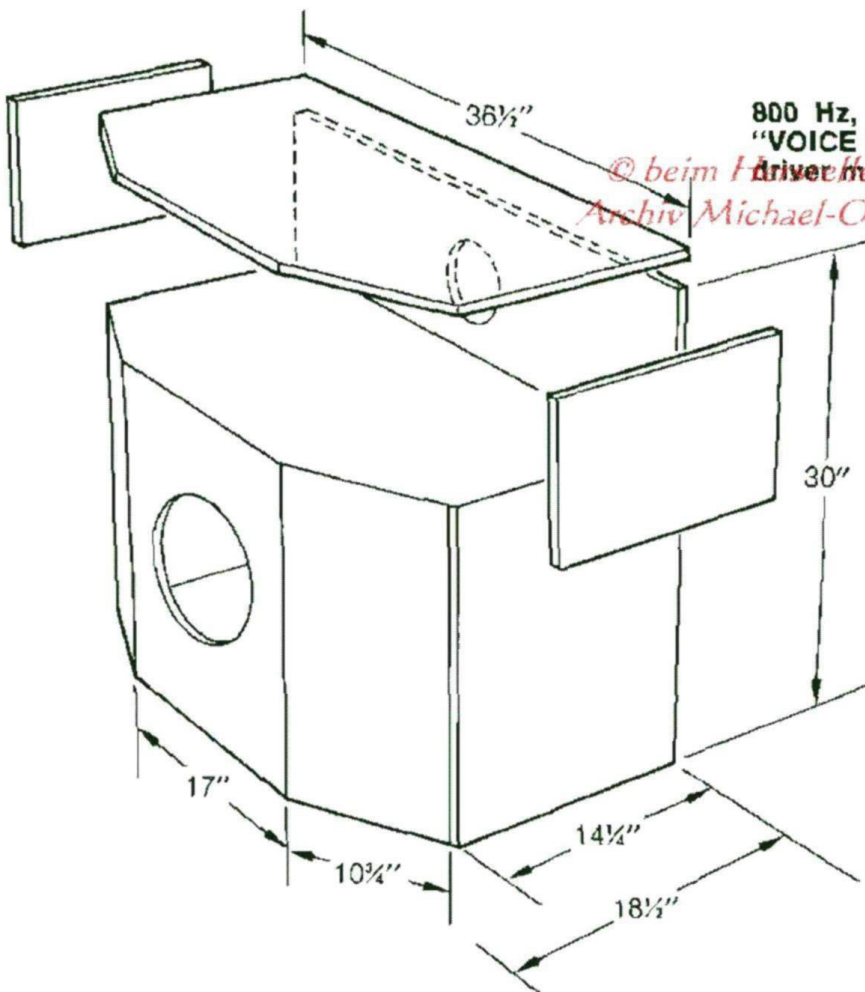

500 Hz, medium efficiency, 411 type home "VOICE OF THE THEATRE" system. HF horn/driver system is mounted on top of LF woofer compartment, and enclosed in decorative shell.

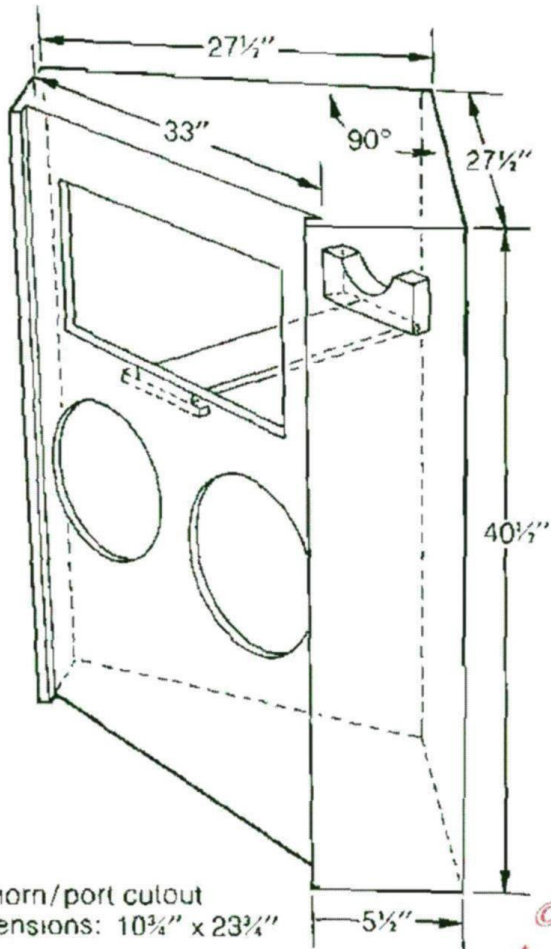

HF horn/port cutout dimensions: 10 1/4" x 23 1/4"

HF horn/driver support shell measurements: Mounting baffle to support cradle: 14 1/8", overall cradle width 6 1/2", opening 4 1/4" x 2 1/4" radius

500 Hz, double woofer, high efficiency home "VOICE OF THE THEATRE" system.

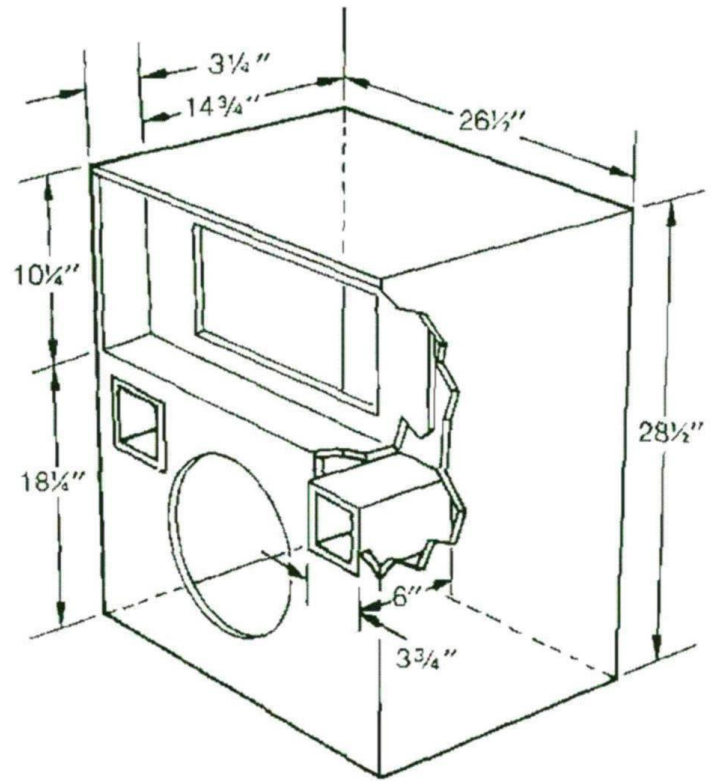

800 Hz High efficiency home "VOICE OF THE THEATRE" SYSTEM

*© beim Hersteller  
Archiv Michael-Otto*

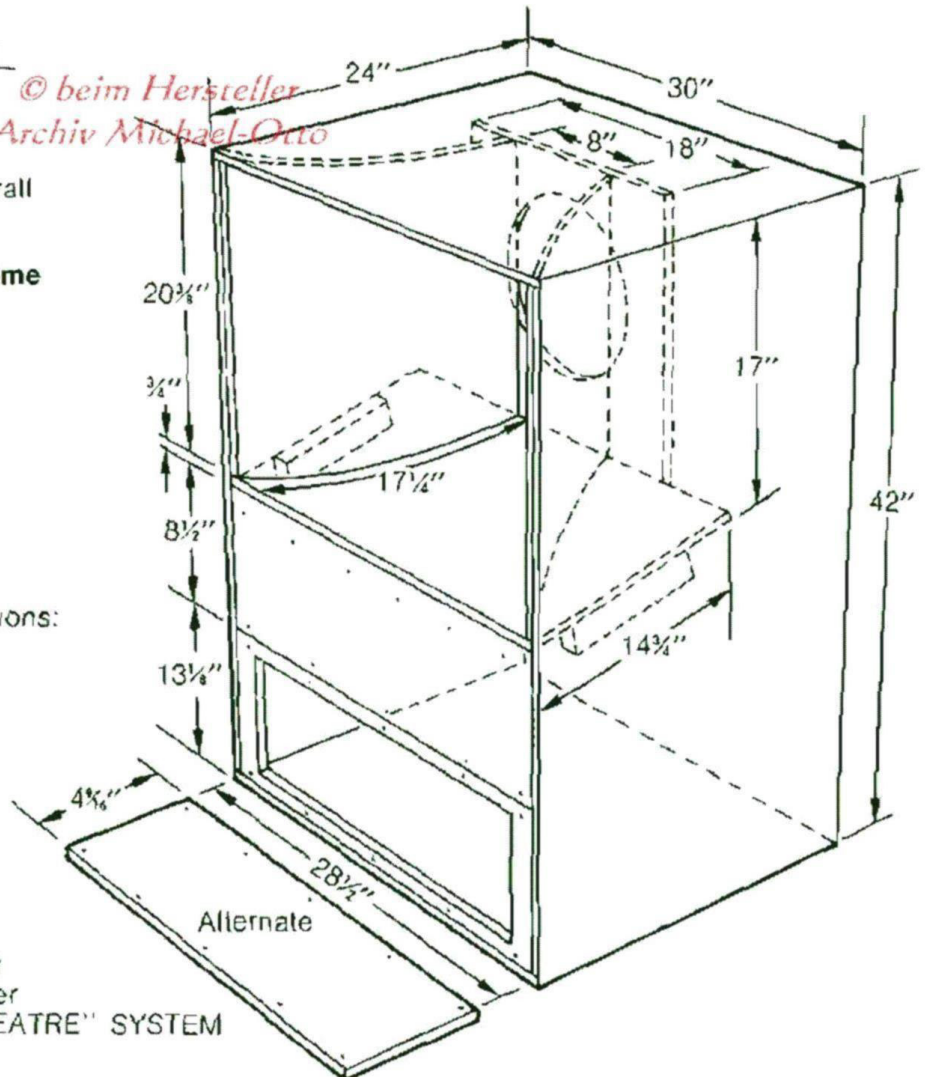

Standard port dimensions: 8 1/8" x 26"

Curved horn section should be adequately braced, not shown in this drawing

Removable boards for matching port to proper "VOICE OF THE THEATRE" SYSTEM

A-7 "VOICE OF THE THEATRE" For either 800 or 500 Hz systems. Shown with alternate port board for internal mounting of A7-500-8A system.

**OUTER DIMENSIONAL DRAWINGS  
FOR SUGGESTED ENCLOSURES  
AND RECOMMENDED LOUDSPEAKERS**

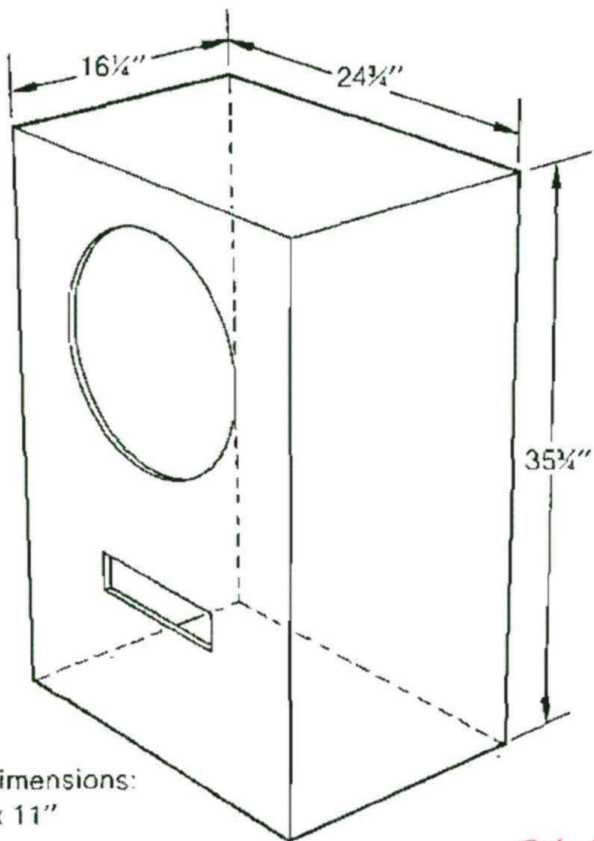

Port dimensions:  
2 1/2" x 11"

**15-Inch Duplex studio monitor enclosures.**

*© beim Hersteller  
Archiv Michael Otto*

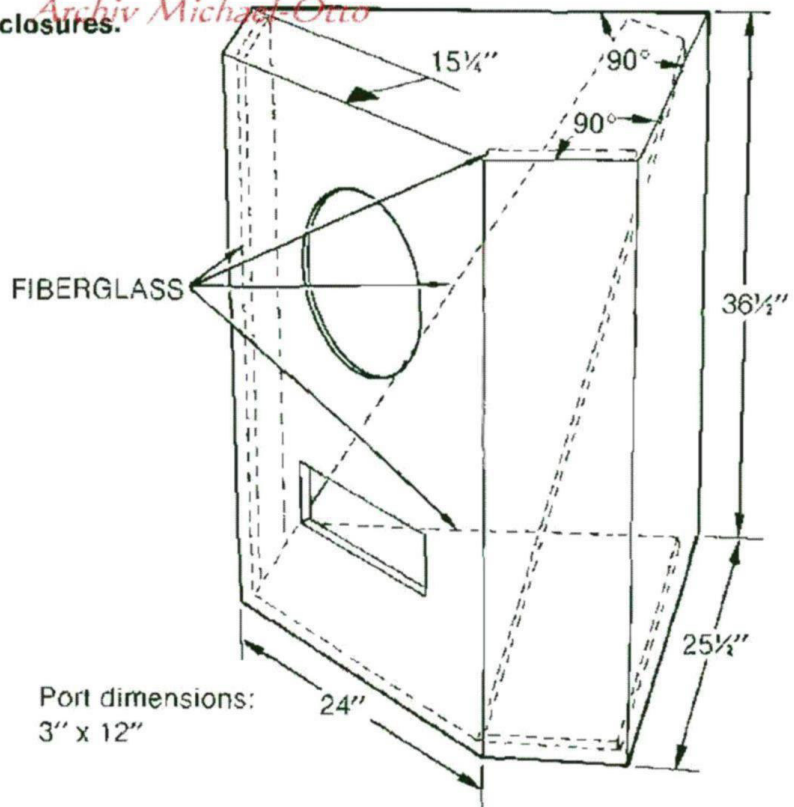

Port dimensions:  
3" x 12"

**15-Inch Duplex studio monitor enclosures.**

Sound level in dB	Environmental conditions
140	Threshold of pain
130	Pneumatic chipper
120	Loud automobile horn
110	Rock concert
100	Police siren
90	Concert level—symphony orchestra
80	Live jazz performance—5 to 8 pieces
70	Inside subway train
60	Live string quartet
50	Inside motor bus
40	Live solo guitar
30	Average traffic on street corner
20	Conversational speech
10	Typical business office
0	Living room, suburban area
	Library
	Bedroom at night
	Empty broadcasting studio
	Threshold of hearing

Some common sound pressure levels.  
References average levels, rather than peak.

### FREQUENCY RANGES OF MUSICAL INSTRUMENTS AND THE HUMAN VOICE

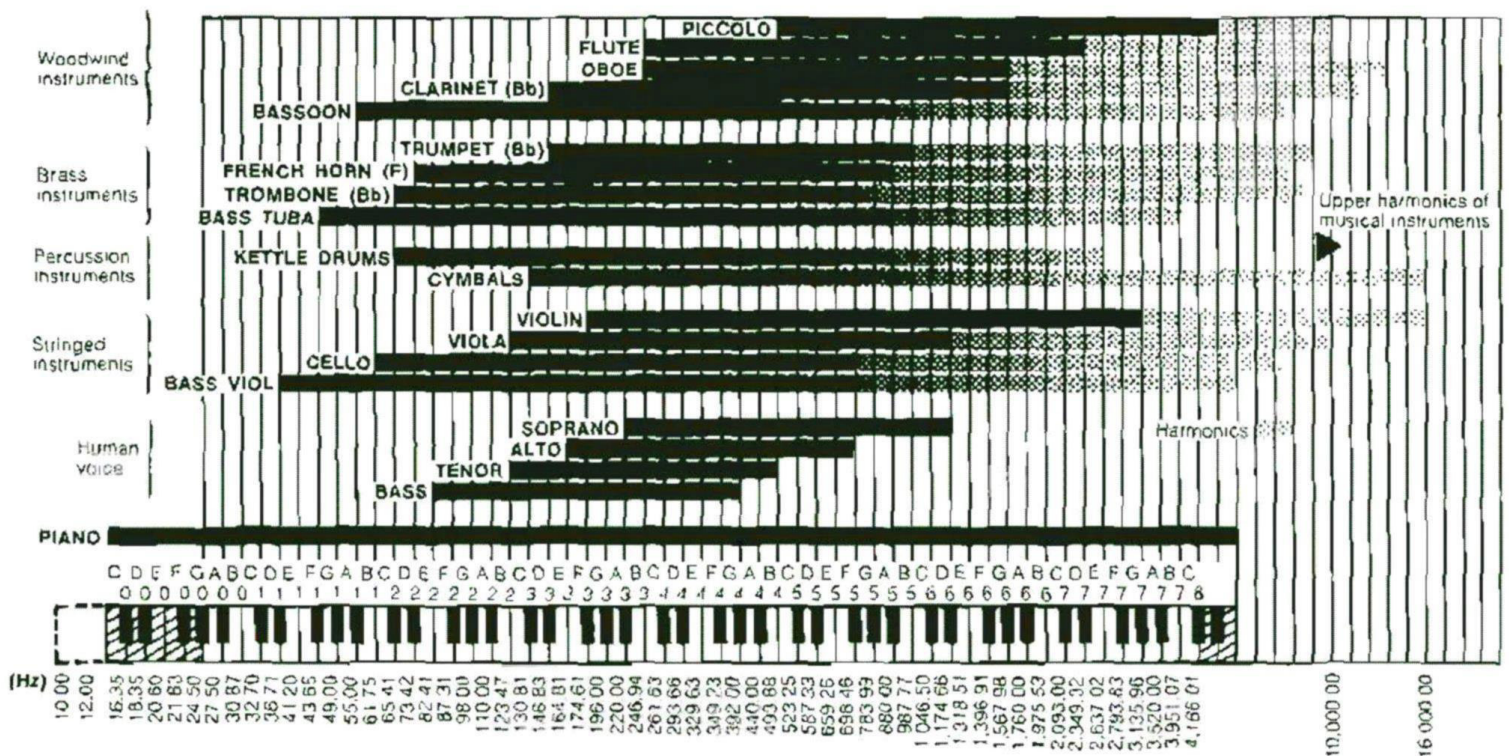

## A GLOSSARY OF AUDIO TERMS

**A-B Test**—Evaluating the relative performance of two (or more) components or systems by switching quickly from one to the other. In comparing, the sudden contrast can reveal audible differences between the units. The fair method of comparison is with no change in the midband volume level. Due to efficiency differences between speaker systems, a method for compensating sensitivity differences should be used.

**Acoustic Feedback**—An annoying interference created when sound vibrations from the speaker system cause a vibration in the record player. The phono stylus can pick up these vibrations, which will be reproduced in the speaker system as a rumble or howl. The cure is to properly isolate the record player from the low frequencies of the speaker system.

**Ambience**—A term referencing a condition of room acoustic characteristics. The total of all sound conditions, but generally excluding the direct sound from the performer or reproducer. Primarily the reflected sound condition, including decay time and frequency emphasis. A condition that might be natural in a hall, or simulated in the record manufacturing process to create a specific hall image.

**Amplifier**—An electronic device for magnifying, and usually controlling, the electrical signals sent to the speaker system. High fidelity amplifying equipment consists of a preamplifier/equalizer section plus a power/basic amplifier section. In integrated amplifiers, both sections are built on one chassis and made available as a single unit. A receiver adds the tuner section to the integrated amplifier.

**Baffle**—A term applied to many areas of a loudspeaker enclosure. Most generally applied to the enclosure itself, but also widely recognized as the loudspeaker mounting board. In horn, and other complex enclosures, the term is applied to individual boards within the enclosure that shape or change the air flow from the transducer. As baffle can be used in all applications, one has to interpret the writer's intention as to true meaning.

**Balance**—A ratio term referring to the relative loudness or amplitude between sound sources. The control sections of stereo and quadraphonic amplifiers have balance controls to allow adjustments between speaker systems that have different pressure sensitivity. The term also applies to frequency response balance. For instance most speaker systems have a balance control in the crossover network to allow adjustment of the volume balance between the transducers in the system.

**Bass Boom**—An effect created by unwanted bass resonances in the sound reproduction. These resonances can be created by many various sources, improperly designed enclosure, cabinet panels not sufficiently braced, or incorrect enclosure size matching to a particular transducer. This publication should solve these problems. An additional source can be standing waves created in the room acoustics. See Standing Waves.

**Compliance**—In loudspeaker language, the term refers to loudspeaker's mechanical suspension—and the suspension's ability to yield to the electrical force applied through the loudspeaker circuit. It is the ratio of cone/diaphragm displacement to a force applied—the inverse of stiffness. A high compliance cone assembly moves easily, and is relatively freely suspended in the loudspeaker frame.

**Compression/Rarefaction**—A dictionary would define compression as "squeezing together" or "making smaller by pressure". In loudspeaker terms we can use the term two ways. As a loudspeaker cone moves forward, the cone applies pressure to the air adjacent to the cone. As this air is compressed by the pressure, it reacts by moving, in a wave form, in a direction away from the pressure. The effect of minus pressure at the rear of the cone, which causes adjacent air to "rush in" and fill the gap of the vacuum created, is called rarefaction. The further use of the term compression relates to certain high frequency transducers. Here the sound waves of the diaphragm are squeezed in a narrow horn throat. The increased pressure and better air coupling offered by a horn, increases efficiency and sound levels—still maintaining low diaphragm travel motion.

**Cone/Diaphragm**—At Altec, we generally use the terms loudspeaker cone or loudspeaker diaphragm interchangeably. It has been used by some companies with cone referencing low frequency transducers, and diaphragm for high frequency units. It is the part which acts as the moving piston in the loudspeaker. The cone or diaphragm is suspended or held in the loudspeaker frame, and moves in relation to the varying source of electrical signal applied to the loudspeaker circuit. A cone or diaphragm assembly, as referenced to a dynamic speaker, would include the surround, which supports and holds the cone to the outer frame, the voice coil, which is wire wound onto a support and completes the loudspeaker circuit with the magnetic gap, and the spider, which helps center the voice coil in the gap and attaches the cone to the inner frame support.

## A GLOSSARY OF AUDIO TERMS

**Crossover Network**—The crossover network is used in a speaker system to divide the signal waveform into frequency bands to feed the appropriate loudspeaker transducer—high frequencies to the tweeter and low frequencies to the woofer. In three-way and four-way systems, more complex networks are required to separate the signal, by frequency, for each particular transducer to reproduce.

**Damping**—As damping is applied to a loudspeaker, it expresses the ability of the cone/diaphragm to stop its motion as the electrical input signal ceases. Poor damping allows motion to continue briefly as an automobile with poor shock absorbers. This hangover creates a "blooming" sound to the bass frequencies, and masks clarity. Amplifiers also have a damping factor which helps control speaker motion. This effect is sometimes highly debated, but the benefits of an amplifier damping factor greater than 30 may be more theory than reality.

**Decibel**—The decibel is a standard unit of measuring amplitude. Usually abbreviated as "dB", the standard is a relative term—rather than an absolute. It is used to compare two different levels, such as voltage, current, or sound pressure level.

**Diaphragm**—See Cone/Diaphragm.

**Distortion**—In referencing playback, any change that the playback system imparts to the source or input sound would be classified as distortion. Distortion can exist at any link in the reproducing chain, and all subsequent links will reproduce the distortion created by an earlier link. Distortion exists in two principal forms—harmonic distortion and intermodulation distortion. Harmonic distortion references the distortion created on the multiple frequencies of a given fundamental frequency. Intermodulation distortion references the interaction of various frequencies, and any distortion created from the interaction. To the ear, IM or intermodulation distortion is generally the most offensive.

**Efficiency**—Efficiency is a term used in discussing loudspeaker output relative to amplifier power input. Efficiency would generally denote a percentage, i.e., 20 percent, 10 percent, or .5 percent efficient. As a 10 percent efficient loudspeaker is high in efficiency, the percentage rating can be misleading. Today's specifications have a trend towards SPL or sound pressure level. This would reference a given dB of loudness, for a given wattage input, at a given distance from the speaker system. In comparing systems or loudspeakers on this basis, 3 dB difference requires half or twice the power—and 10 dB change requires one tenth or ten times the power for a given standard of input sensitivity measurements.

**Enclosure**—In loudspeaker terms we refer to the enclosure as the acoustically designed housing for the loudspeaker.

**Equalization**—A deliberate, introduced change in frequency response would be called equalization. There are many forms of equalization; as used in disc recording and playback, tape recording and playback, graphic tone balance, room equalization, and speaker equalization. As the term implies, everything comes out "equal" in the end—with flat overall response between microphone input and loudspeaker output.

**Excursion**—The actual movement of the cone/diaphragm assembly is referred to as excursion. The allowable cone travel, or excursion, is a factor that is important to high power applications. Linear cone travel is necessary for low distortion.

**Fidelity**—The degree of faithfulness to the original—accuracy and honesty in sound reproduction. See Distortion.

**Frequency**—The rate of repetition in Hertz of musical pitch, as well as that of electrical signals. Hertz, as previously termed cycles-per-second, tells us how many repetitions exist per second of time in a given signal. Low frequencies refer to bass tones, and high frequencies to treble tones.

**Frequency Response**—The ability of a component to reproduce a range of frequencies is called frequency response. How evenly the component responds to various frequencies within the range describes how "flat" that response would be. In loudspeaker and speaker systems, the quotation of a response range or flatness can be very misleading. The environment in which the measurement takes place can have so many variables, and does not necessarily relate to performance in the listening room, that meaningful specifications relating to frequency response are not currently available for loudspeakers or systems.

**Hertz**—See Frequency.

**Impedance**—An engineering term which describes the degree to which a circuit impedes the flow of an alternating current. See text for fuller explanation as applies to loudspeakers.

**Loudness Compensation**—The human ear experiences a loss in sensitivity, particularly in the bass frequencies, and somewhat in the high frequencies, at low volume levels. Loudness compensation corrects this by increasing the bass frequencies and highs in the correct proportions as the volume is decreased from a concert level.

## A GLOSSARY OF AUDIO TERMS

**Loudspeaker/Transducer**—The terms Altec uses to describe the unmounted loudspeaker. Also referred to as a "raw frame" loudspeaker, and designates without an enclosure.

**Phase**—Refers to any part of a sound wave or an electrical signal with respect to its passage in time. Two devices are in-phase when they furnish the signal or sound simultaneously. They are out-of-phase to the extent that, at a point in time, one lags or leads the other. In two-way and three-way speaker systems, it might be necessary, as a part of design, to create an out-of-phase electrical condition in order to create an in-phase acoustical condition.

**Power**—Power is the electrical energy developed to do work, such as the power from an amplifier used to drive a speaker system. Also, acoustical energy or sound pressure developed in a room by a speaker system.

**Pressure Sensitivity**—The specification of pressure sensitivity relates to the sound pressure level from loudspeaker output, relative to a given electrical power input. See also Efficiency. *© Heinz Heintze Archiv Michael-Orto*

**Resonance**—Resonance refers to the tendency of any physical body to vibrate most freely at one particular frequency. In audio, the electrical and mechanical resonances of the various components must be controlled so that they do not affect the tonal quality of the music being reproduced. Also see text concerning impedance and resonance.

**Room Acoustics**—The natural acoustics of the listening room play a large part in determining the overall sound of the system. Altec encourages your experimentation in various speaker placements to determine what sounds best in your room. In general, attempt to have opposite surfaces of opposite textures—such as hard and absorbent. Also see further information under Standing Waves.

**Rumble**—As its name suggests, rumble is a low frequency rumbling noise produced by poorly built turntables or record changers. Because of the low frequencies of rumble, it can often be confused with acoustic feedback. Proper speaker system placement requires a good understanding of both acoustic feedback and rumble.

**Spider**—The spider is the name of the mechanical collar, located at the neck of the cone/diaphragm, which fastens the cone to the inner portion of the loudspeaker frame and helps keep the voice coil centered in the magnetic gap.

**Standing Waves**—As the sound or music is reproduced from the speaker systems, the wave fronts move forward through the listening room, hit the opposite wall, and are then reflected back into the listening area. Depending on the ceiling height, room width and length, these waves can create an in-phase or out-of-phase condition which is detrimental to reproduction. Most frequent problems in the average room occur with an in-phase condition at 80 and 200 Hz. The goal is to eliminate these standing waves by experimenting with various speaker placements.

**Surround**—The surround is the mechanical collar which fastens the outer edge of the cone/diaphragm to rim of the loudspeaker basket. Various materials are used to achieve the degree of compliance desired.

**Watts**—The watt is a unit of electrical or acoustical power. The term designates the power consumed in an electrical device. In audio we specify not the power to keep the amplifier running, but rather the amount of audio power the amplifier is capable of delivering to the speaker system. Because the loudspeaker is not a particularly efficient device, the acoustic output power from the loudspeaker, in watts, is far less than the amplifier audio power input.

*© beim Hersteller  
Archiv Michael-Otto*

**ALTEC**

SOUND PRODUCTS DIVISION

1515 SOUTH MANCHESTER AVENUE, ANAHEIM, CALIFORNIA 92803