

1978

ALTEC
LANSING

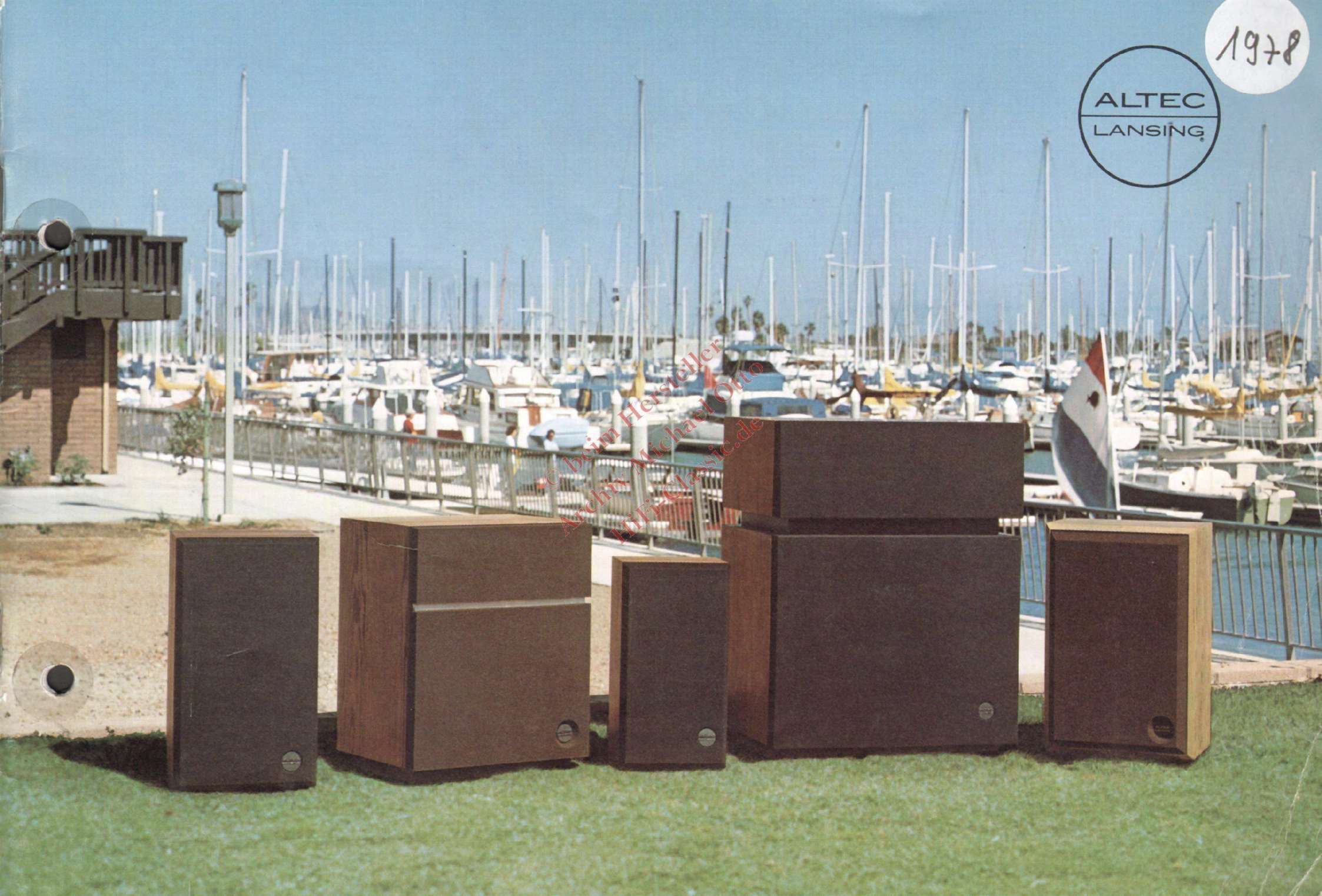

© beim Hersteller
Archiv Michael Otto
HiFi-Classic.de



η
 Ω β 2
 π

© beim Hersteller
Archiv Michael Otto
mfo-classic.de

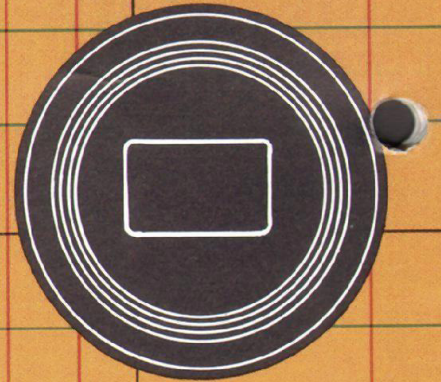
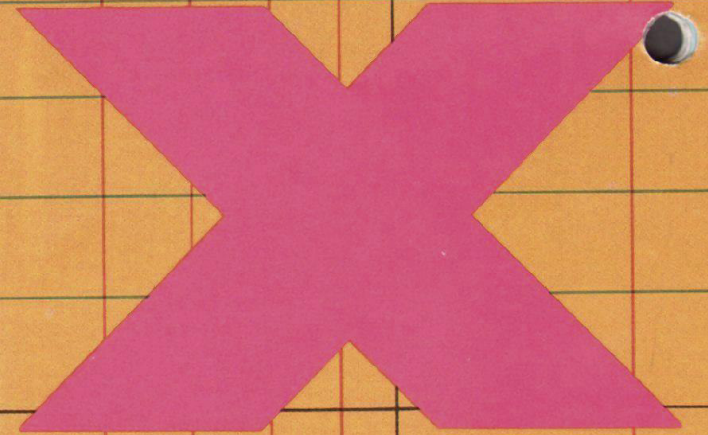
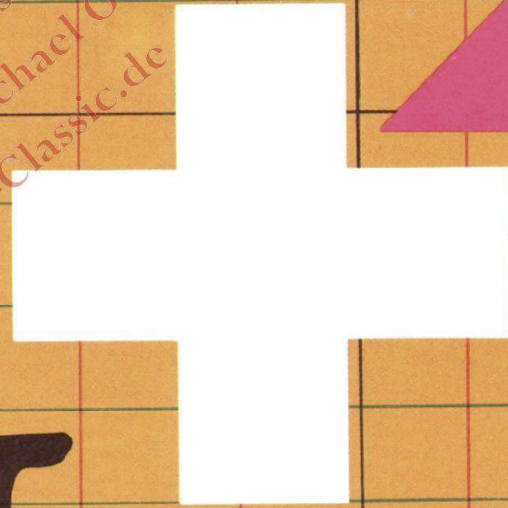

ABOUT OUR CATALOGUE

We at Altec Lansing have long been proud of the heritage we possess — over four decades of leadership in professional sound. Recording studio monitors, theatre sound systems, permanently installed high level sound reinforcement systems, portable sound reinforcement equipment — the list of Altec Lansing leadership goes on. Wherever professionalism in sound is the requirement, Altec Lansing is there.

We have carried our tradition of quality and professionalism into every facet of our involvement — and now with a special emphasis on equipment for the home. We have pooled our traditions, talents, and experience in engineering, design, and manufacturing to produce a most comprehensive line of quality loudspeakers and speaker systems — products of professional quality and heritage, yet products that will enhance any living environment.

In many cases these products are identical or share the same components as products destined for professional application. We, more than anyone, understand the differences and the similarities in requirements for professional products and home high fidelity reproducers. Quite often the home reproducer can pose a completely different set of performance criteria to challenge the creativity of the design team. We have accepted this challenge, and the products displayed in this catalogue exemplify the output of our creative efforts, designed especially for use in the living environment.

This catalogue is not only intended to display our products, but to represent our philosophy as well. That philosophy is one of optimization. Optimization of science, art, talent, and effort, resulting in the optimum in performance, styling, and value. We now bring to you, through this catalogue, a statement of that philosophy interwoven with a display of what we feel is the finest line of high fidelity reproducers available. We trust that this catalogue will make easier one of the most difficult purchasing decisions facing the consuming world: The choice of a high fidelity speaker system.

We are confident that after examining our product line and reviewing the philosophy presented by this catalogue, there will be but one choice open.

ALTEC LANSING



SERIES II

The Second Generation of Altec Lansing's Bookshelf Models

Perhaps more than any other single audio component, the speaker-on-the-shelf has come to represent Hi Fi. Its classic design and compact size have made it a favorite the world over. But all bookshelf speakers are far from being equal.

At Altec Lansing, we have always believed that our speakers should deliver outstanding performance. So we invest years of research and refinement in every product we make.

The result of this effort — the Series II Bookshelf Line.

Five speakers — each an exceptional performer. Each made better by subtle changes in acoustic design, construction techniques and material selection. Changes like the new hybrid magnet design found in the Models One through Seven.

Until now, speaker magnet structure design was either of the traditional Alnico or ceramic type.

The Alnico type uses a voice coil that surrounds the magnet. It has been found, however, that the interaction of the voice coil and the magnet will eventually cause the magnet to partially demagnetize. The result is a loss of sensitivity and a muddy bass sound.

The ceramic magnet poses a different problem. Here the voice coil moves around the pole piece and is surrounded by the magnet. The thinner magnet, however, creates a clearance problem for the voice coil.

The Altec Lansing hybrid magnet design combines the best of both magnet types. The new design still has the magnet around the voice coil, but the new "top hat" design eliminates the clearance problem.

Of course the one thing we would never change is the quality that Altec Lansing is known for. We still make all our own speaker components and all our bookshelf speakers are finished with real wood veneers.

So if you're looking for top performance combined with the classic appearance of a bookshelf speaker, ask your Altec Lansing dealer for a demonstration of the Series II speakers. We don't think you'll have to look any further.



(A) MODEL ONE SERIES II



(B) MODEL THREE SERIES II



(C) MODEL FIVE SERIES II



(D) MODEL SEVEN SERIES II



(E) MODEL NINE SERIES II

	(A) MODEL ONE SERIES II	(B) MODEL THREE SERIES II	(C) MODEL FIVE SERIES II	(D) MODEL SEVEN SERIES II	(E) MODEL NINE SERIES II
SPEAKER COMPONENTS					
LOW FREQUENCY:	8" bass driver	10" bass driver	12" bass driver	12" bass driver	12" bass driver
MID FREQUENCY:				6½" frame cone driver	6½" frame cone driver
HIGH FREQUENCY:	4" frame cone driver	4" frame cone driver	2 each 4" frame cone drivers	4" frame cone driver	5" frame cone driver
NOMINAL IMPEDANCE:	8 ohms	8 ohms	8 ohms	8 ohms	8 ohms
CROSSOVER FREQUENCY:	3500 Hz	1500 Hz	1500 Hz	850 Hz, 8 kHz	800 Hz, 7 kHz
ENCLOSURE TYPE:	Sealed	Vented	Vented	Vented	Vented
SENSITIVITY:	89 dB SPL	90.5 dB SPL	91.5 dB SPL	90 dB SPL	93 dB SPL
Measured at 4 feet, 1 watt input referenced to 8 ohms, using pink noise which has been limited to a bandwidth of 500 Hz to 3 kHz.					
FREQUENCY RESPONSE:	50 Hz to 20 kHz	50 Hz to 20 kHz	45 Hz to 20 kHz	45 Hz to 20 kHz	40 Hz to 20 kHz
DISPERSION:	120° at -6 dB vertical 125° at -6 dB horizontal	120° at -6 dB vertical 140° at -6 dB horizontal	90° at -6 dB vertical 120° at -6 dB horizontal	120° at -6 dB vertical 130° at -6 dB horizontal	110° at -6 dB vertical 115° at -6 dB horizontal
Measured with pink noise limited to bandwidth of 800 Hz — 8 kHz at a distance of 4 feet.					
LONG TERM BROAD BAND MAXIMUM POWER:	30 watts	35 watts	45 watts	50 watts	60 watts
Measured with a source of pink noise limited to the frequency response bandwidth of the system, over an extended time period.					
AMPLIFIER OPERATING RANGE:*	10 watts to 75 watts	10 watts to 100 watts	12 watts to 150 watts	15 watts to 200 watts	12 watts to 250 watts
Recommended minimum and maximum amplifier power.					
LONG TERM MAXIMUM ACOUSTIC OUTPUT:	104 dB SPL at 30 watts	106 dB SPL at 35 watts	108 dB SPL at 45 watts	107 dB SPL at 50 watts	110.5 dB SPL at 60 watts
Measured with a source of pink noise limited to the frequency response bandwidth of the system at a distance of 4 feet.					
FINISH:	Hand-rubbed oiled walnut	Hand-rubbed oiled oak	Hand-rubbed oiled walnut	Hand-rubbed oiled walnut	Hand-rubbed oiled oak
GRILLE:	Acoustically transparent brown knit fabric mounted on removable frame	Acoustically transparent black knit fabric mounted on removable frame	Acoustically transparent black knit fabric mounted on removable frame	Acoustically transparent foam mounted on removable panel. Choice of black or brown	Acoustically transparent foam mounted on removable panel. Choice of black or brown
DIMENSIONS:	22½"H x 12"W x 11"D 57cm H x 30.5cm W x 28 cm D	24"H x 12½"W x 11½"D 60.9cm H x 31.8cm W x 29.2 cm D	25½"H x 14½"W x 12"D 64.8cm H x 36.8cm W x 30.5cm D	25"H x 16"W x 14⅞"D 63.5cm H x 40.6cm W x 35.9cm D	26½"H x 17½"W x 15"D 67.3cm H x 44.5cm W x 38.1cm D
SHIPPING WEIGHT:	30 lbs. — 27.2 kg (2 units per carton)	32½ lbs. — 14.7 kg	38¼ lbs. — 17.4 kg	49¼ lbs. — 22.3 kg	64 lbs. — 29 kg
NET WEIGHT:	26 lbs. — 11.8 kg	26¼ lbs. — 12 kg	32 lbs. — 14.5 kg	43¼ lbs. — 20 kg	56 lbs. — 25.4 kg

*Amplifier operating range is for amplifier selection guidance only. Do not mistake it for the speaker's power capacity. Refer to page 16 for further clarification.



© beim Hersteller
Archiv Michael Otto
HiFi-Classic.de

A

B

C

E

D

SERIES II

The Second Generation of Altec Lansing's Bookshelf Models

Perhaps more than any other single audio component, the speaker-on-the-shelf has come to represent Hi Fi. Its classic design and compact size have made it a favorite the world over. But all bookshelf speakers are far from being equal.

At Altec Lansing, we have always believed that our speakers should deliver outstanding performance. So we invest years of research and refinement in every product we make.

The result of this effort — the Series II Bookshelf Line.

Five speakers — each an exceptional performer. Each made better by subtle changes in acoustic design, construction techniques and material selection. Changes like the new hybrid magnet design found in the Models One through Seven.

Until now, speaker magnet structure design was either of the traditional Alnico or ceramic type.

The Alnico type uses a voice coil that surrounds the magnet. It has been found, however, that the interaction of the voice coil and the magnet will eventually cause the magnet to partially demagnetize. The result is a loss of sensitivity and a muddy bass sound.

The ceramic magnet poses a different problem. Here the voice coil moves around the pole piece and is surrounded by the magnet. The thinner magnet, however, creates a clearance problem for the voice coil.

The Altec Lansing hybrid magnet design combines the best of both magnet types. The new design still has the magnet around the voice coil, but the new "top hat" design eliminates the clearance problem.

Of course the one thing we would never change is the quality that Altec Lansing is known for. We still make all our own speaker components and all our bookshelf speakers are finished with real wood veneers.

So if you're looking for top performance combined with the classic appearance of a bookshelf speaker, ask your Altec Lansing dealer for a demonstration of the Series II speakers. We don't think you'll have to look any further.



(A) MODEL ONE SERIES II



(B) MODEL THREE SERIES II



(C) MODEL FIVE SERIES II

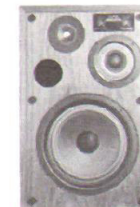

(D) MODEL SEVEN SERIES II



(E) MODEL NINE SERIES II

	(A) MODEL ONE SERIES II	(B) MODEL THREE SERIES II	(C) MODEL FIVE SERIES II	(D) MODEL SEVEN SERIES II	(E) MODEL NINE SERIES II
SPEAKER COMPONENTS					
LOW FREQUENCY:	8" bass driver	10" bass driver	12" bass driver	12" bass driver	12" bass driver
MID FREQUENCY:				6½" frame cone driver	6½" frame cone driver
HIGH FREQUENCY:	4" frame cone driver	4" frame cone driver	2 each 4" frame cone drivers	4" frame cone driver	5" frame cone driver
NOMINAL IMPEDANCE:	8 ohms	8 ohms	8 ohms	8 ohms	8 ohms
CROSSOVER FREQUENCY:	3500 Hz	1500 Hz	1500 Hz	850 Hz, 8 kHz	800 Hz, 7 kHz
ENCLOSURE TYPE:	Sealed	Vented	Vented	Vented	Vented
SENSITIVITY:	89 dB SPL	90.5 dB SPL	91.5 dB SPL	90 dB SPL	93 dB SPL
Measured at 4 feet, 1 watt input referenced to 8 ohms, using pink noise which has been limited to a bandwidth of 500 Hz to 3 kHz.					
FREQUENCY RESPONSE:	50 Hz to 20 kHz	50 Hz to 20 kHz	45 Hz to 20 kHz	45 Hz to 20 kHz	40 Hz to 20 kHz
DISPERSION:	120° at -6 dB vertical 125° at -6 dB horizontal	120° at -6 dB vertical 130° at -6 dB horizontal	90° at -6 dB vertical 120° at -6 dB horizontal	120° at -6 dB vertical 130° at -6 dB horizontal	110° at -6 dB vertical 115° at -6 dB horizontal
Measured with pink noise limited to bandwidth of 800 Hz — 8 kHz at a distance of 4 feet.					
LONG TERM BROAD BAND MAXIMUM POWER:	30 watts	35 watts	45 watts	50 watts	60 watts
Measured with a source of pink noise limited to the frequency response bandwidth of the system, over an extended time period.					
AMPLIFIER OPERATING RANGE: *	10 watts to 75 watts	10 watts to 100 watts	12 watts to 150 watts	15 watts to 200 watts	12 watts to 250 watts
Recommended minimum and maximum amplifier power.					
LONG TERM MAXIMUM ACOUSTIC OUTPUT:	104 dB SPL at 30 watts	106 dB SPL at 35 watts	108 dB SPL at 45 watts	107 dB SPL at 50 watts	110.5 dB SPL at 60 watts
Measured with a source of pink noise limited to the frequency response bandwidth of the system at a distance of 4 feet.					
FINISH:	Hand-rubbed oiled walnut	Hand-rubbed oiled oak	Hand-rubbed oiled walnut	Hand-rubbed oiled walnut	Hand-rubbed oiled oak
GRILLE:	Acoustically transparent brown knit fabric mounted on removable frame	Acoustically transparent black knit fabric mounted on removable frame	Acoustically transparent black knit fabric mounted on removable frame	Acoustically transparent foam mounted on removable panel. Choice of black or brown	Acoustically transparent panel. Choice of black or foam mounted on removable brown
DIMENSIONS:	22½"H x 12"W x 11"D 57cm H x 30.5cm W x 28 cm D	24"H x 12½"W x 11½"D 60.9cm H x 31.8cm W x 29.2 cm D	25½"H x 14½"W x 12"D 64.8cm H x 36.8cm W x 30.5cm D	25"H x 16"W x 14½"D 63.5cm H x 40.6cm W x 35.9cm D	26½"H x 17½"W x 15"D 67.3cm H x 44.5cm W x 38.1cm D
SHIPPING WEIGHT:	30 lbs. — 27.2 kg (2 units per carton)	32½ lbs. — 14.7 kg	38¼ lbs. — 17.4 kg	49¼ lbs. — 22.3 kg	64 lbs. — 29 kg
NET WEIGHT:	26 lbs. — 11.8 kg	26¼ lbs. — 12 kg	32 lbs. — 14.5 kg	43¼ lbs. — 20 kg	56 lbs. — 25.4 kg

*Amplifier operating range is for amplifier selection guidance only. Do not mistake it for the speaker's power capacity. Refer to page 16 for further clarification.

A FEAST FOR THE EARS — Four Contemporary Floor-Standing Models

Professionals in the music industry — recording engineers, musicians, acoustical engineers — all demand and expect the closest thing to realism in sound reproduction. For four decades Altec Lansing has met this challenge in producing audio standards for the industry.

Now we offer our latest contribution in professional monitoring to home Hi Fi buyers. Our intense engineering research has resulted in dynamic new performance in several systems. And we have found overwhelming evidence to prove that proper tuning for vented enclosures can result in superb low frequency performance.

Four floor-standing models speak for the quality, professionalism and creativity of design that is Altec Lansing. They include the Model 19, Model 18, Model 15, and the Santana II — each one utilizing components that are designed and manufactured exclusively by Altec Lansing. Except for the 18, each system may stand freely in a room with beautiful hand-rubbed wood on all sides.

The top-of-the-line Model 19 as well as the Models 18 and 15 utilize a new high-frequency driver built around the Tangerine™ radial phase plug. And there's an innovative new dividing network/equalizer featuring both mid- and high-frequency level controls. The Model 18, developed specifically for critical, professional studio monitoring, features the 604-8H speaker, the reference standard of the recording industry for decades. The 604-8H features a new horn design which we call Mantaray™*. The Mantaray is a unique design in horn technology. It is the product of very sophisticated computer analysis of horn and driver impedance, amplitude and directivity characteristics. It is a true "constant directivity" design, which means that the dispersion is constant at all frequencies: a theoretical challenge which is now a reality.

Completing the floor-standing line is the Santana II, a two-way system with 12-inch bass driver and a 5-inch high-frequency driver. The Santana II is walnut with composition-slate top, a perfect balance of great sound and functional furniture.



(A) NINETEEN •

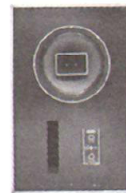

(B) EIGHTEEN •



(C) FIFTEEN •



(D) SANTANA II

	(A) NINETEEN •	(B) EIGHTEEN •	(C) FIFTEEN •	(D) SANTANA II
SPEAKER COMPONENTS				
LOW FREQUENCY:	15" bass driver (416-8B)	15" driver with coaxially mounted constant-directivity control horn and compression driver (Model 604-8H)	12" bass driver	12" bass driver
HIGH FREQUENCY:	Radial Phase Plug driver mounted to 811B sectoral horn		Radial Phase Plug driver mounted to curved radial horn	5" frame cone driver
NOMINAL IMPEDANCE:	8 ohms	8 ohms	8 ohms	8 ohms
CROSSOVER FREQUENCY:	1200 Hz	1500 Hz	1700 Hz	2500 Hz
ENCLOSURE TYPE:	Vented	Vented	Vented	Vented
SENSITIVITY:	99 dB SPL**	103 dB SPL	93 dB SPL**	89 dB SPL
Measured at 4 feet, 1 watt input, using pink noise which has been limited to a bandwidth of 500 Hz to 3 kHz.				
FREQUENCY RESPONSE:	30 Hz to 20 kHz	30 Hz to 20 kHz	30 Hz to 20 kHz	40 Hz to 20 kHz
DISPERSION:	105° at -6 dB vertical 105° at -6 dB horizontal	50° at -6 dB* vertical 70° at -6 dB* horizontal	120° at -6 dB vertical 120° at -6 dB horizontal	130° at -6 dB vertical 130° at -6 dB horizontal
Measured with pink noise limited to a bandwidth of 500 Hz — 8 kHz at a distance of 4 feet.				
LONG TERM BROAD BAND MAXIMUM POWER:	65 watts**	65 watts	60 watts**	45 watts
Measured with a source of pink noise limited to the frequency response bandwidth of the system over an extended time period.				
AMPLIFIER OPERATING RANGE:***	10 watts to 350 watts	10 watts to 350 watts	12 watts to 250 watts	12 watts to 150 watts
Recommended minimum and maximum amplifier power.				
LONG TERM MAXIMUM ACOUSTIC OUTPUT:	117 dB SPL at 65 watts**	118 dB SPL at 65 watts	108 dB SPL at 60 watts**	107.5 dB SPL at 45 watts
Measured with a source of pink noise limited to the frequency response bandwidth of the system at a distance of 4 feet.				
FINISH:	Hand-rubbed oiled walnut or oak	Hand-rubbed oiled oak	Hand-rubbed oiled oak or walnut	Hand-rubbed oiled walnut with composition slate top
GRILLE:	Acoustically transparent knit fabric mounted on removable frame. Black supplied with walnut, brown with oak cabinet	Visually and acoustically transparent knit fabric mounted on removable frame	Acoustically transparent foam mounted on removable panel. Black supplied with walnut, brown with oak cabinet	Acoustically transparent black knit fabric mounted on removable frame
DIMENSIONS:	39"H x 30"W x 21"D with base and grille 99.6cm H x 76.2cm W x 53.3cm D	40"H x 26"W x 18"D 102cm H x 66cm W x 45.7cm D	27"H x 22"W x 15½"D with base and grille 68.6cm H x 55.9cm W x 38.7cm D	25¾"H x 19"W x 16"D 65.9cm H x 48.3cm W x 40.6cm D
SHIPPING WEIGHT:	166 lbs. — 72.3 kg	168 lbs. — 77.1 kg	84 lbs. — 38.1 kg	67 lbs. — 30.4 kg
NET WEIGHT:	143 lbs. — 64.9 kg	138 lbs. — 62.6 kg	76 lbs. — 34.5 kg	57 lbs. — 25.9 kg

*800 Hz — 8 kHz

**Measured with shelving controls set at optimum.

***Amplifier operating range is for amplifier selection guidance only. Do not mistake it for the speaker's power capacity. Refer to page 16 for further clarification.

• Tangerine™ radial phase plug.



© beim Hersteller
Archiv Michael Otto
Multi-Classic.de



B



C



A



D

HIGH FREQUENCY COMPRESSION DRIVER

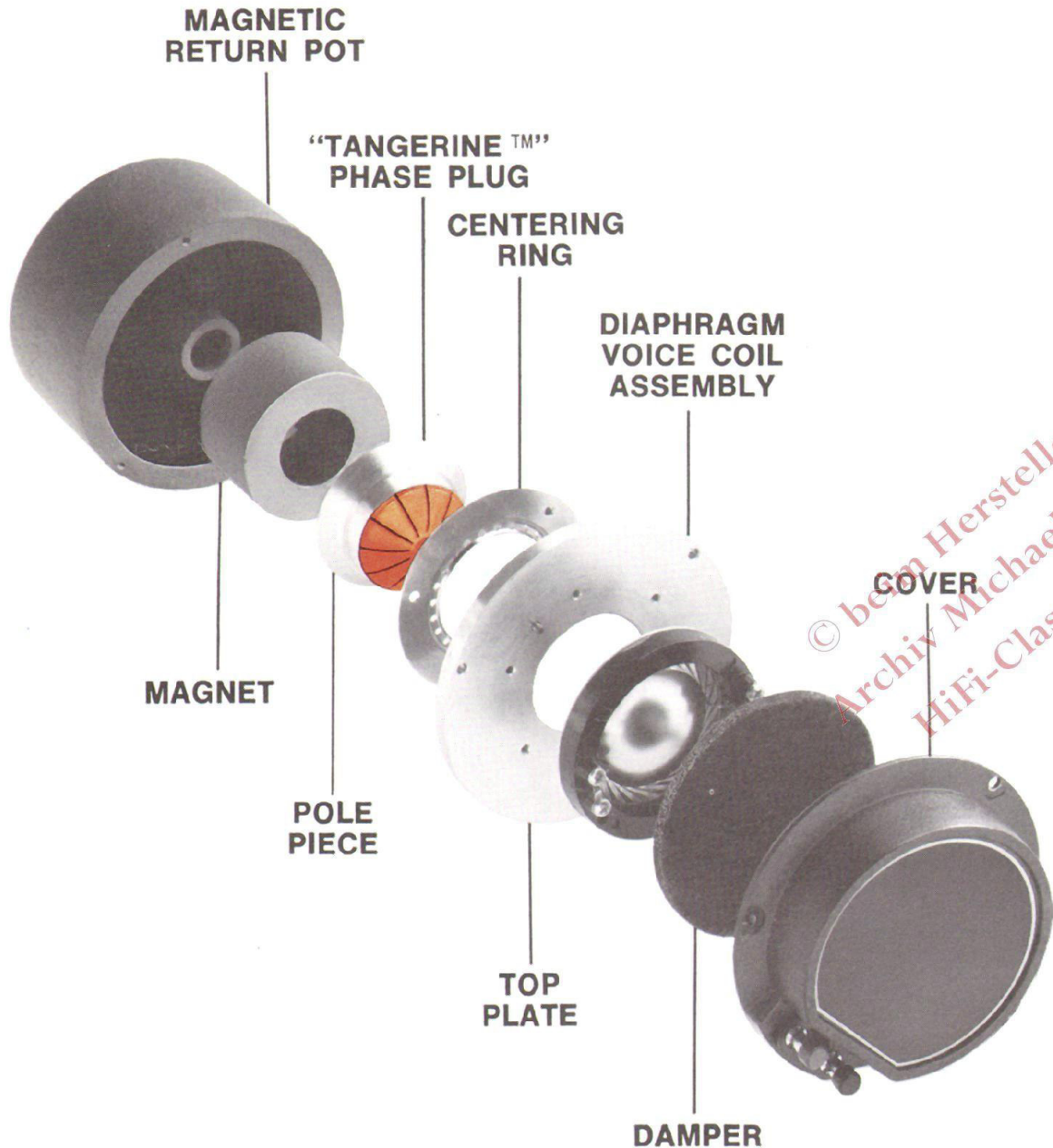

INTRODUCING THE TANGERINE™

High frequency compression drivers used by most companies contain a circumferential type phase plug which was developed by our noble ancestor, Western Electric, in the 1920's.

Our new radial plug, the Tangerine™— looking very much like a peeled tangerine and hence its name — allows far more high-frequency energy to enter the horn than traditional phase plugs. And so high-frequency response is extended.

The super Models 19, 15, A7X, and 18 all feature this remarkably improved element along with an improved equalizer/crossover network that permits smooth, gradual equalization of the mid and high frequencies.

... and the improved 802-8G Driver

In addition to the Tangerine™ phase plug design, the 802-8G employs stronger, lighter epoxies for a lighter moving assembly and improved power capacity. This new high-frequency driver also features sub-crossover resonance and equalized pressure loading for lower distortion.



VOICE OF THE THEATRE — A Legend

The Voice of The Theatre. Known by name, known by sight and known by reputation as a legend.

In the 1950's the Academy of Motion Picture Arts and Sciences officially recognized the Voice of The Theatre as *the standard* in motion picture theatre sound. Once an exclusively professional product, it became the system demanded by audiophiles who insisted on its unparalleled presence and efficiency for their homes.

Today, the excitement, drama, emotion and realism of movie sound is duplicated by the voice of The Theatre.

Tight low-frequency response, high-frequency projection and power handling capability, trademarks of the Voice of The Theatre, are refined to new levels of perfection in our all-new A7X. It utilizes the patented Tangerine™ radial phase plug in the powerful 802-8G driver, and the new Model N1201-8A equalizer/dividing network with a crossover frequency of 1200 Hz.

Excellent frequency response, bandwidth, power capacity and acoustic output are all featured in this system and must be experienced to be believed.

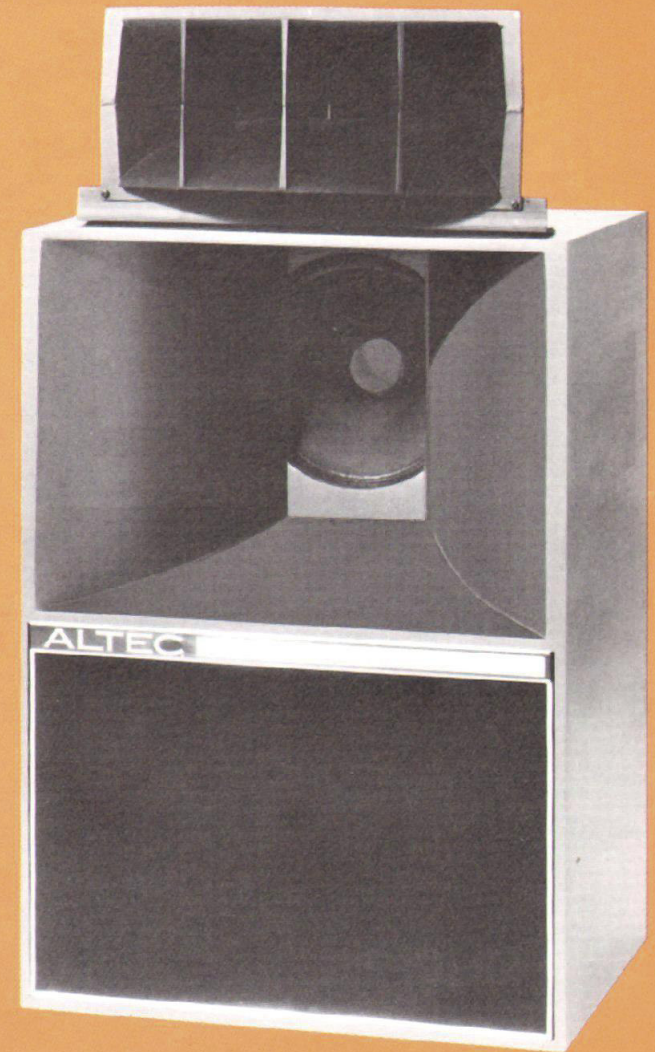
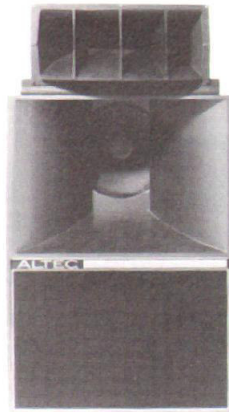

A7X •

SPEAKER COMPONENTS	15" bass driver (416-8B)
LOW FREQUENCY:	
HIGH FREQUENCY:	• 802-8G compression driver mounted to 511B sectoral horn
NOMINAL IMPEDANCE:	8 ohms
CROSSOVER FREQUENCY:	1200 Hz (N1201-8A network)
ENCLOSURE TYPE:	Horn-loaded with reflex port
SENSITIVITY:	100 dB SPL
Measured at 4 feet, 1 watt input referenced to 8 ohms, using pink noise which has been limited to a bandwidth of 500 Hz to 3 kHz.	
FREQUENCY RESPONSE:	45 Hz to 20 kHz
DISPERSION:	60° at -6 dB vertical
Measured with pink noise limited to a bandwidth of 500 Hz to 8 kHz.	90° at -6 dB horizontal
LONG TERM BROAD BAND MAXIMUM POWER:	100 watts
Measured with a source of pink noise limited to the frequency response bandwidth of the system, over an extended time period.	
AMPLIFIER OPERATING RANGE:*	10 watts to 350 watts
Recommended minimum and maximum amplifier power	
TERM MAXIMUM ACOUSTIC OUTPUT:	120 dB SPL at 65 watts
Measured with a source of pink noise limited to the frequency response bandwidth of the system at a distance of 4 feet.	
FINISH:	Metallic gray
DIMENSIONS:	52¼" H x 30" W x 24" D
	137.8cm H x 76.2cm W x 61.2cm D
SHIPPING WEIGHT:	163 lbs. — 76.2 kg
ACTUAL WEIGHT:	142 lbs. — 64.54 kg

• Tangerine™ radial phase plug.

*Amplifier operating range is for amplifier selection guidance only. Do not mistake it for the speaker's power capacity. Refer to page 16 for further clarification.

EXTENDED RANGE LOUDSPEAKERS

604-8H (15") Duplex Monitor.*

Long a standard of the professional recording industry, the 604 series presents a degree of perfection known to no other single precision reproducer. Outstanding efficiency is the result of a high-frequency driver and horn coaxially mounted to a highly efficient low-frequency speaker. The unique constant-directivity horn (we call it Mantaray™)* produces the same dispersion pattern regardless of frequency. Once regarded as a theoretical impossibility, it is now a reality. A unique, dual-variable equalizer/dividing network is included.

405A (4").

For its size, the 405A will reproduce speech clearly and music well with a frequency response of 60 to 1500 Hz. It performs admirably in an enclosure between 1/4 and 1 cubic foot, and remains a favorite in automobile sound installations.

LOW FREQUENCY LOUDSPEAKERS

416-8B (15").

As the woofer used in the A-7 series Voice of The Theatre Systems, the professional quality 416-8B yields smooth response with extraordinary linearity. It combines nicely with an Altec Lansing compression driver, sectoral horn, and dividing network.

411-8A (15").

A woofer of medium efficiency, the 411-8A is designed to work in a sealed enclosure having an internal volume range from 4 to 8 cubic feet.

414-8C (12").

Used extensively in high accuracy reproduction as well as in professional studios, the 414-8C has the power capacity for excellent high fidelity. It is designed for use in 2 1/2 to 10 cubic feet enclosures.

	604-8H •	416-8B	411-8A	414-8C	405A
IMPEDANCE:	8 ohms	8 ohms	8 ohms	8 ohms	8 ohms
CROSSOVER FREQUENCY:	1500 Hz	—	—	—	—
DIMENSIONS:	16" (40.6 cm) diameter 11 1/8" (28.3 cm) deep	16" (40.6 cm) diameter 7" (17.8 cm) deep	15 3/8" (38.9 cm) diameter 5 7/8" (14.9 cm) deep	12 1/4" (31.4 cm) diameter 5 3/4" (14.6 cm) deep	4 9/8" (11.1 cm) square 2 1/8" (5.4 cm) deep
WEIGHT:	34.0 lb. 15.4 kg (includes dividing network)	17 1/2 lb. 7.9 kg	20 1/2 lb. 9.3 kg	15 lb. 6.8 kg	2 lb. 0.9 kg
FINISH:	Dark gray enamel	Dark gray enamel	Dark gray enamel	Dark gray enamel	Gray enamel
MOUNTING DATA—BAFFLE OPENING:	14 1/8" (35.9 cm) (front or rear mounting)	14 1/8" (35.9 cm) (front or rear mounting)	14 1/8" (35.9 cm) front mounting 13 3/4" (34.9 cm) rear mounting	11 1/8" (28.3 cm) diameter (front or rear mounting)	4 5/8" (10.6 cm) front mounting 3 1/8" (9.7 cm) rear mounting
MOUNTING BOLT CENTERS:	8 or 4 bolts equally spaced on 15" (38.1 cm) diameter circle	8 or 4 bolts equally spaced on 15" (38.1 cm) diameter circle	14 5/8" (37.1 cm) diameter circle	4 bolts equally spaced on 11 1/8" (29.4 cm) diameter circle	4 bolts equally spaced at 90° on 4 1/8" (11.9 cm) diameter circle
COMPLEMENTARY COMPONENTS:	Dual equalizer dividing network (supplied)	811B horn, N1201-8A network, 802-8G driver, 511B horn,	811B horn, 802-8G driver, 511B horn.	802-8G driver, 811B horn, N1201-8A network	—

• Tangerine™ radial phase plug.

*U.S. and Foreign Patents pending.

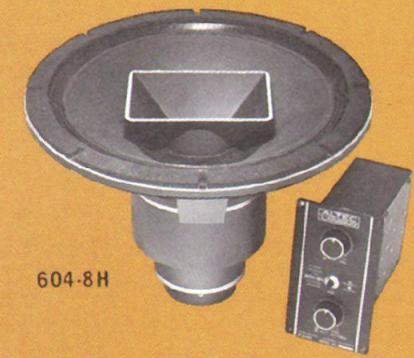

604-8H

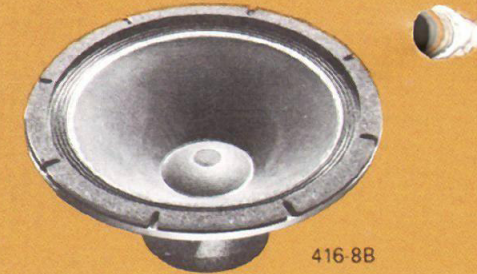

416-8B



411-8A



414-8C



405A

© behm Hersteller
Michael Otto
HiFi-Classic.de

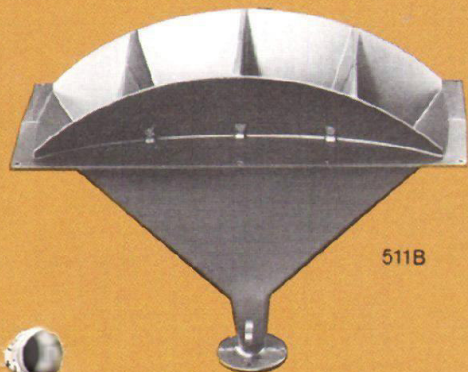

511B

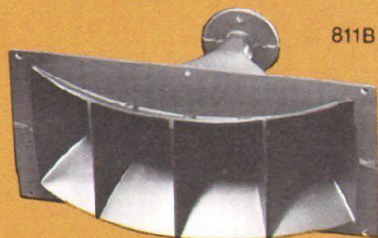

811B



802-8G



N1201-8A



HIGH-FREQUENCY LOUDSPEAKERS

511B, 811B Sectoral Horns.

The wide horizontal shaping of the cast aluminum sectoral horn tightly controls the very important dispersion pattern of sound. When equipped with a compression driver, these horns reproduce the full range of frequencies, while maintaining uniform directivity.

802-8G High-Frequency Compression Driver.

Compression drivers are capable of a much wider bandwidth and vastly higher sensitivity than cone-type high frequency reproducers, making possible extremely high sensitivity in two-way systems when coupled with appropriate bass speakers. The Tangerine™ radial phase plug in the 802-8G yields extended frequency response.

N1201-8A Equalizer/Dividing Network.

Altec Lansing precision crossover networks are designed to optimally match the frequency response of compression drivers and horns to bass drivers. The highly sophisticated Model 19

and A7X monitor systems contain the remarkable N1201-8A variable equalizer/dividing network which offers smooth, gradual equalization. This feature is highly desirable in adjusting speakers to the acoustic properties of the room and to personal listening tastes.

	HIGH-FREQUENCY COMPRESSION DRIVER	SECTORAL HORNS		DIVIDING NETWORK
	802-8G •	511B	811B	N1201-8A
IMPEDANCE:	8 ohms	—	—	8 ohms
MINIMUM CROSSOVER FREQUENCY:	1200 Hz*	500 Hz	800 Hz	1200 Hz
DIMENSIONS:	4½" (11.43 cm) diameter, 3¼" (9.7 cm) deep	10⅝"H x 23½"W x 18½"D 27.0cm H x 59.7cm W x 47.0cm D	8⅝"H x 18½"W x 13½"D 21.9cm H x 47.0cm W x 39.3cm D	7½"H x 4½"W x 8⅝"D 19.0cm H x 11.4cm W x 22.8cm D
WEIGHT:	7 lb. 3.18 kg	12.3 lb. 5.6 kg	9 lb. 4.1 kg	4 lb. 1.8 kg
FINISH:	Dark gray enamel	Flat black	Flat black	Flat black
COMPLEMENTARY COMPONENTS:	511B, 416-8B, 414-8C, N1201-8A, 811B	802-8G, 411-8A, 416-8B, N1201-8A	802-8G, 411-8A, 416-8B, 414-8C, N1201-8A	811B, 511B, 416-8B, 414-8C, 802-8G

• Tangerine™ radial phase plug.

*The 802-8G may be used as low as 500 Hz with system input power not exceeding 35 watts.

COMPONENTS AND THEIR MATCHING SYSTEMS

If you are planning to build your own enclosures, we have provided for you a set of guidelines for completing a variety of systems. For your convenience, we have provided this system guide with which to select the components that will best suit your needs.

© beim Hersteller
Archiv Michael Otto
HiFi-Classic.de



System Components for A7X



System Components for Model 19

SPECIFICATIONS DEFINED

What is their significance?

How are they measured?

All speaker manufacturers have their own methods for evaluating and rating the performance of their products, and universal measuring techniques for some characteristics are impossible to achieve. While we cannot offer a means of deciphering other manufacturers' specifications, we do offer an explanation of our own.

Speaker Components

All of our low-frequency and mid-frequency drivers utilize cones as the moving elements. Our high-frequency drivers are either cone drivers or compression drivers, depending on the model you select. Compression drivers usually produce a wider range of frequencies and have greater sensitivity, but are more expensive and require a horn to disperse their energy.

The size of the driver itself does not imply what the performance will be like. What we are trying to accomplish with our products is optimum performance within a given set of parameters. Size, price, and the laws of physics dictate what can be done. Certain tradeoffs involving woofer size, efficiency, enclosure size, and low frequency response characteristics are made in order to optimize performance.

Nominal Impedance

All of our high fidelity products are now standardized at 8 ohms impedance. It is important to know the impedance when operating more than one set of speakers at a time, since adding speakers in parallel lowers the impedance. If the impedance drops too low, it can endanger the amplifier. "Zero ohms" is a short circuit; potentially, disaster to an amplifier.

Crossover Frequency

The crossover point(s) for each system is specifically selected to optimize the overall performance of that system. The crossover frequency indicates the point at which the response of two speaker components (such as a woofer and mid range) intersect, or cross over. It is important to know that this is not the point at which a driver stops operating; rather, it is the point at which the driver radiates about 50% of its mean output level, and continues to radiate energy below (or above) this point.

Enclosure Type

In its more than 40 year history, Altec Lansing has developed systems using nearly every major type of enclosure tuning method, and we have many different types in use today. Vented and conventional reflex, horn loaded, sealed enclosures. Why does Altec Lansing not subscribe to the hypothesis that one tuning method is clearly better than any other? Because there is no one universally best method. Altec Lansing selects its tuning method as part of a total package of parameters to deliver the most desirable low-frequency performance from a given product—a study in performance optimization.

Sensitivity

Sensitivity, or efficiency, is one of the most important, yet most overlooked performance parameters. It indicates how efficient a unit is, how much acoustic output it can deliver for a given amount of electrical input. The larger the number, the more sensitive, or efficient, the unit is. For example, a speaker with a sensitivity rating of 100 dB SPL will deliver 10 times the acoustic output of a speaker with a rating of 90 dB SPL given the same amount of input power. This is like the difference between a 10-watt amplifier and a 100-watt amplifier!

Why consider a speaker of modest sensitivity? Sensitivity is expensive. It either costs money, size, response at the low and high ends of the audio band, distortion, or a combination of all of these.

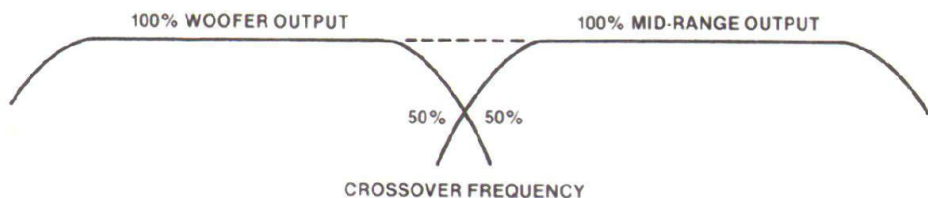

Sound level in dB	Environmental conditions
140	Threshold of pain
130	Pneumatic chipper
120	Loud automobile horn
	Rock concert
110	Police siren
	Concert level—symphony orchestra
100	Live jazz performance—5 to 8 pieces
	Inside subway train
90	Live string quartet
	Inside motor bus
80	Live solo guitar
	Average traffic on street corner
70	Conversational speech
60	Typical business office
50	Living room, suburban area
40	Library
30	Bedroom at night
20	Empty broadcasting studio
10	Threshold of hearing
0	

Some common sound pressure levels. References average levels, rather than peak.

Frequency Response

Frequency response tells us the practical limits at the extremes of the audio band, and is always measured directly in front of the center of a speaker, a place you would never sit when listening to stereo. And the fact is that frequency response can change drastically with a very slight movement of the measuring point.

Frequency response cannot tell you "how much bass or treble" a speaker will produce; it cannot, nor can any specification or group of specifications, tell you how a speaker will sound—only a well devised and careful listening test can do that.

It is our recommendation that you exercise the ultimate option—the listening test—as the deciding factor for selecting a speaker system. Your Altec Lansing dealer will provide the best possible listening environment and comparison facilities—use them.

FREQUENCY RANGES OF MUSICAL INSTRUMENTS

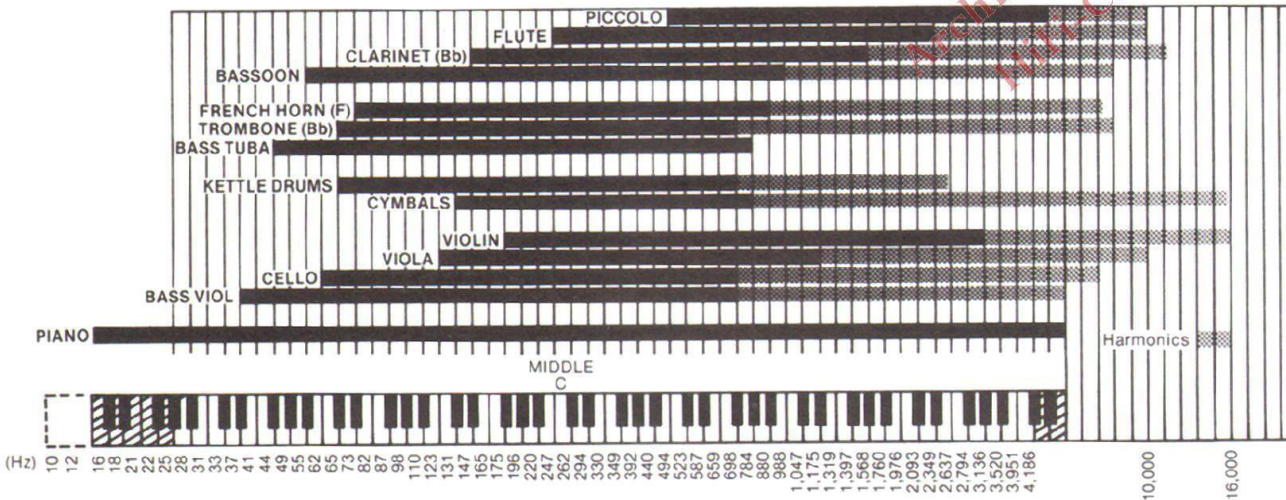

Dispersion

This specification tells us how much and in what pattern a speaker system spreads out its energy. Since, as a general rule, higher frequencies spread their energy less than lower frequencies, we use a high-frequency signal to measure the dispersion of our speakers.

"90° at -6 dB horizontal" means that if we were to look at an arc 90° wide, with the center directly in front of the speaker, the amount of energy at the edges of the arc would be 6 dB less than or about 25% of that at the center.

Is dispersion good or bad? An adequate dispersion pattern is required to convey a good stereo image and to prevent "beaming" (concentrating the sound directly in front of the speakers).

But too broad a dispersion pattern can distort the stereo panorama or cause frequency cancellation by environmental surface reflection, a frequent problem with most omnidirectional speakers.

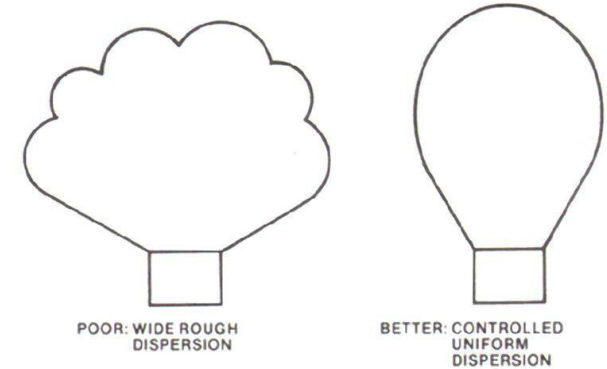

Long-Term Broad-Band Maximum Power

This is the "worst case" rating and is much more severe than normal use. The system is driven using pink noise* which has been limited by electronic filtering to its frequency response bandwidth. It is then driven for several hours. After a successful test, the power is increased in 5-watt increments. The unit is tested until it fails, and the rating is the level of the step used before failure.

Amplifier Operating Range

Amplifier operating range is the range of minimum to maximum amplifier power that should be used with the unit. This allows for a larger amplifier which can easily pass high-level power peaks in the program material — peaks which are often more than 10 times the average program level.

Although a large amplifier can damage speakers, so can a small one. Keep in mind that an amplifier's rating is at or below a given distortion level; this does not mean the amplifier will cease to generate power at this point. Some amplifiers are capable of power greatly exceeding their "rated" power, but it is highly distorted and with greater damaging potential than an undistorted signal at the same level.

Most any amplifier can damage a speaker. To prevent speaker burnout, use common sense, and discuss it with your Altec Lansing dealer. When the signal becomes distorted, you are overdriving the speaker, or amplifier, or both. And remember, the tone controls increase output just as the volume control does, so avoid large amounts of tone compensation at high levels.

Long-Term Maximum Acoustic Output

This is a measure of how loud a system can play. It takes into consideration both power handling and sensitivity. Measurement is made at the long-term, broadband, maximum power level. The larger the number, the higher the level. The system is capable of more output for short term power peaks, just as it is capable of more power input than specified, but not on an extended time basis.

***A Note on "Pink Noise"**

Most of our specifications are measured with pink noise as opposed to white noise because pink noise most closely duplicates the effect of music on speaker components under controlled test conditions. Pink noise is a constant amount of energy per octave, while white noise, sometimes used by other manufacturers, is a constant amount of energy per cycle. Due to the extreme difference in Hertz from octave to octave, white noise measurements can distort the specification's meaning.



Your Altec Lansing Dealer is:



Domestic Offices:

Altec Lansing International
1515 So. Manchester Avenue
Anaheim, California 92803
U.S.A.
Telephone: 714/774-2900
Telex: 65-5415

10500 West Reno Avenue
Oklahoma City, Oklahoma 73126
U.S.A.
Telephone: 405/354-5311
Telex: 74-8510

International Offices:

17 Park Place
Stevenage
Hertfordshire
SG11DU, England
Telephone: 0438-3241
Telex: 825495

Altec Lansing of Canada, Ltd.,
151 Carlingview Dr., No. 5,
Rexdale, Ontario
Canada M9W5E7
Telephone: 416/675-1177
Telex: 06-968634

FULL 5-YEAR WARRANTY

Altec Lansing has always been a manufacturer of fine audio equipment. And we are one of only a few manufacturers who back up their products with a full five-year warranty.

Altec Lansing warrants all loudspeaker systems to be free from defects in materials and workmanship for a period of five years from the date of purchase. For warranty repair, the defective product should be delivered to an authorized Altec Lansing Servicing Dealer, authorized warranty station, or Altec Lansing factory repair center. In addition, the warranty may be transferred to any subsequent owners during the five-year warranty period.

A thorough Warranty Protection statement is enclosed with each Altec Lansing unit purchased.