

250A

ALTEC

LANSING CORPORATION

console...

1957

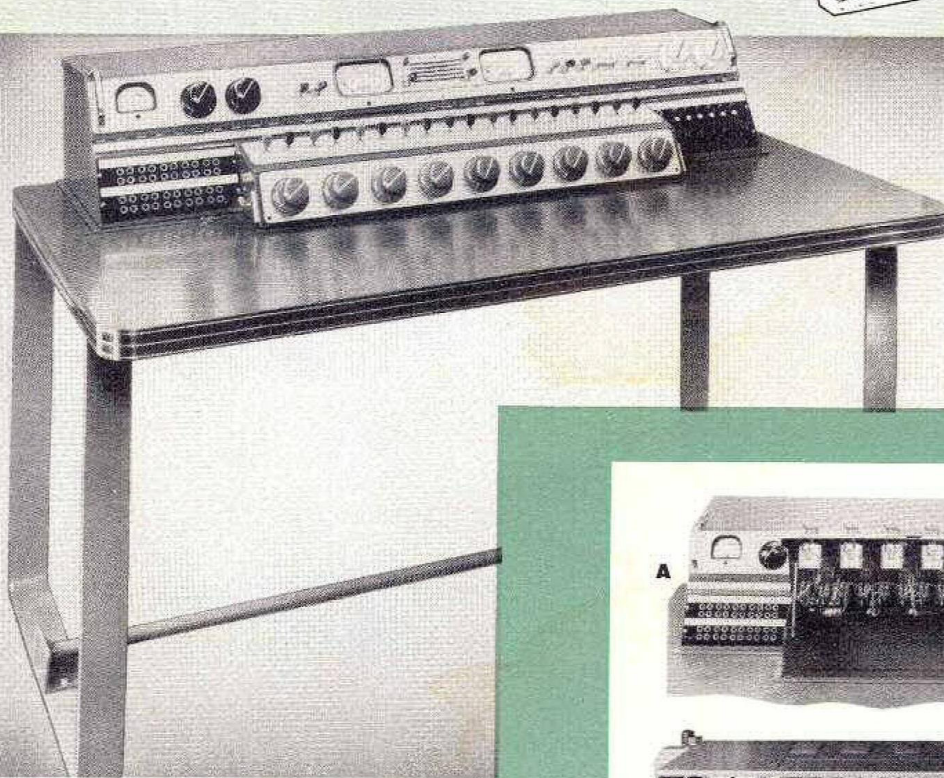

A The hinged front panel exposes all mixing pots and switches, and the entire wiring of the console.

B Opening the top of the console exposes all of the plug-in amplifiers and power supplies. The tube testing buttons are on the ends of the units.

For the ultimate in quality control the new Altec 250A Console is the finest unit ever made for AM, FM or TV studio use. Its compactness, flexibility and accessibility are made possible by the use of newly designed miniature plug-in preamplifiers, line amplifiers and power supplies. The preamplifiers are only 1 7/8" wide, 4 1/4" high and 9" long. The line amplifiers and power supplies are 2 3/8" x 4 1/4" x 9". The complete console contains five A-428A preamplifiers for microphone preamplification and two A-428A preamplifiers for boosters. There are provisions for two additional preamplifiers for increased microphone input facilities. There are three A-429A line amplifiers, two P-522A power supplies and one P-523A power supply. The 250A Console is neatly mounted in a 55" long green formica topped desk that leaves ample space for scripts, cueing sheets and notes. There are no external components to be hidden in the walls, placed in racks or stacked in the corner. The 250A is a completely self-contained AC operated program production console for the amplification, control and monitoring of programs from microphones, transcriptions, tape, remote inputs or other equivalent sources.

The 250A Console has nine mixing controls and 18 input channels. These inputs are connected to selection switches permitting the choice of either of two channels on each mixing control. As standard equipment five of the mixing controls are connected

with ten low level microphone inputs. Each of the other four mixers is connected to one line input and one utility input. This provides a total of ten microphone inputs, four line inputs and four utility inputs. Two of the line inputs can be converted for microphone use by plugging two extra preamplifiers into the wired receptacles provided in the console. These two preamplifiers must be purchased as extra equipment.

The output from each of the nine mixer controls can be switched to either of the two output channels. Each of these output channels has its own master mixing control, an illuminated VU meter and a phone jack for headset monitoring. Any of the inputs can be directed to either of these two output channels without fear of crosstalk or interference. There is also an independent channel for loudspeaker monitoring of either of the outputs, any of the incoming lines, or the cue circuits. This monitor channel may also be used to feed cue programs

back to the remote line circuits, or for talkback on either of the two studio loudspeaker circuits.

The console is wired to receive four 15036 line input repeating coils which are available as extra equipment and should be ordered separately. Provision has also been made for the connection of studio light and signalling control circuits. Connections are available for either an external talkback microphone or for one mounted behind the grille in the center of the console.

All controls are color coded according to function and grouped in the most efficient manner for sure convenient operation. The hinged face and top give complete access to every part of the console without the need of moving it from the wall. The wiring is simple and straightforward and terminal strips are located in both ends of the console for all permanent connections. The absence of external connection boxes or plugs eliminates the danger of accidental disconnection.

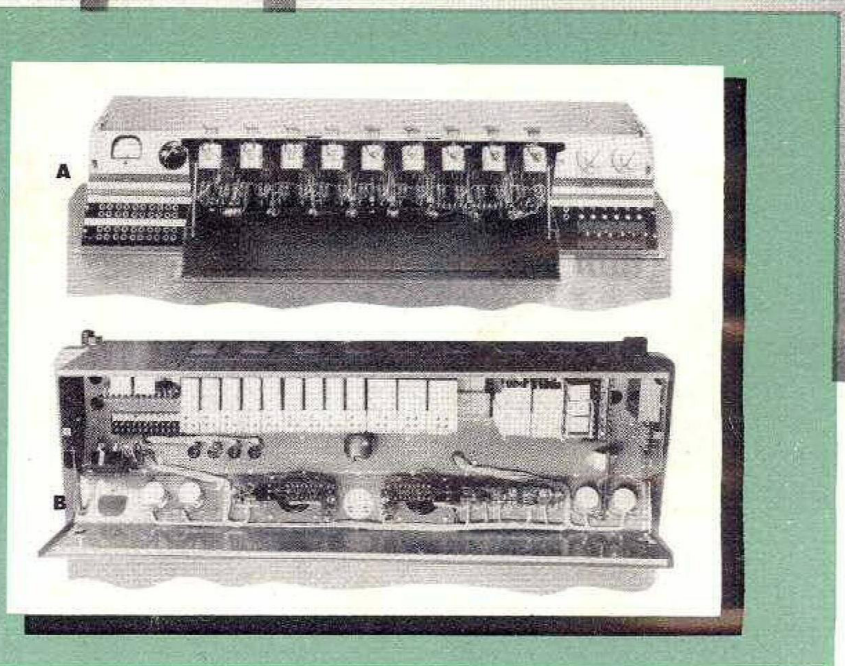

preamplifiers & line amplifiers

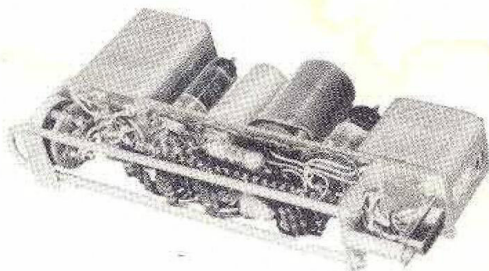
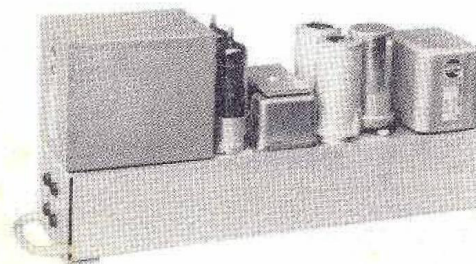
**A-428A Preamplifier***(cover tray removed showing open chassis design)***A-429A Line or Monitor Amplifier***(with cover tray showing push buttons for tube checking)*

Gain:	40 db (or 34 db with special connections)
Source Impedance:	30, 150, 250, 600 ohms
Load Impedance:	75, 150, 300, 450, 600 ohms
Frequency Response:	± 1 db from 20 to 20,000 c. p. s.
Output Level:	+ 20 dbm with less than 1/2% total harmonic distortion from 50 to 15,000 c. p. s.
Noise Level:	Equivalent input noise level is less than - 124 dbm with a 20,000 c. p. s. bandwidth
Tube Complement:	2 - 5879, 1 - 6AQ5
Power Required:	0.75 a., 6.3 VAC and 12 ma., 250 VDC
Size:	1 5/8 in. wide, 9 in. long, 4 1/4 in. high

Gain:	50 db
Source Impedance:	30, 150, 250, 600 ohms
Load Impedance:	150, 600 ohms
Frequency Response:	± 1 db from 20 to 20,000 c. p. s.
Output Level:	+ 30 dbm at less than 0.5% total harmonic distortion from 30 to 15,000 c. p. s. as line amplifier, or + 39 dbm (8 watts) at less than 1% total harmonic distortion from 50 to 15,000 c. p. s. as monitor amplifier
Noise Level:	Equivalent input noise level is less than - 110 dbm with a 20,000 c. p. s. bandwidth
Tube Complement:	2 - 5879, 2 - 6AQ5
Power Required:	1.2 a., 6.3 VAC and 28 ma., 270 VDC as line amplifier; 1.2 a., 6.3 VAC and 70 ma., 270 VDC as monitor amplifier
Size:	2 3/8 in. wide, 9 in. long, 4 1/4 in. high

Though designed primarily for use in the 250A Console these new miniature preamplifiers and line amplifiers are perfectly adapted for any other application. Each unit is supplied with a cover tray which can be permanently mounted in a rack or

cabinet. Part of this tray is the receptacle to which all connections are made. The unit itself slides easily into the tray and automatically centers its plug with the receptacle. This plug-in feature combined with the open design of the amplifiers leaves

all parts readily accessible for service when removed from the tray. Another feature is the push button switches on the end of the amplifier chassis for use in individual tube checking.

power supplies

Like the amplifiers these small plug-in power supplies were designed for use in the 250A Console but are adaptable for use in custom installations. They use the same cover tray and receptacle designs as the amplifiers and contain all of the features of those units described above. The P-522A unit uses two 6X4 tubes but the P-523A which contains the loudspeaker muting relays is equipped with a selenium rectifier.

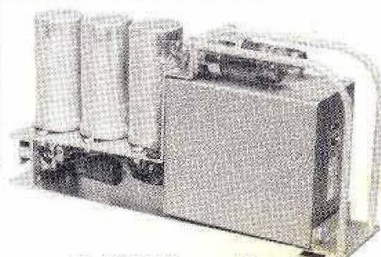
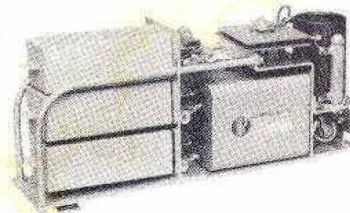
**P-522A Power Supply***(for plate and filament voltages)***P-523A Power Supply***(for relay and signal lamps)*

Output:	5.1 amp @ 6.3 Volts A. C. 130 ma @ 270 Volts D. C.
Tubes:	2 - 6X4
Dimensions:	2 3/8" x 4 1/4" x 9"

Output:	2 amp @ 12 Volts D. C.
Dimensions:	2 3/8" x 4 1/4" x 9"

outstanding features

250A
CONSOLE

Plug-in preamplifiers, line amplifiers and power supplies (for easy service and instant replacement).

Open chassis design on preamplifiers, amplifiers and power supplies (for ease of test and repair).

Wide range frequency response (± 1 db 20-20,000 cycles).

Very low distortion . . . Very low noise level.

18 inputs.

Up to twelve balanced line microphone inputs (mix 7 simultaneously).

Excellent balance—high attenuation of longitudinal currents for all frequencies up to 20,000 cycles.

4 line inputs, 4 utility inputs for turntable, etc. (mix 4 simultaneously).

2 channel 2 line output operation. Switch channels to either line instantly.

Flush mounted illuminated 4" VU meters, one for each channel.

VU meter cut-off switches and three position attenuators.

Self-contained (no external power supplies, etc.).

Compact (only 36" x 31" x 55" including desk).

Operator designed (the right height and the right size).

Color coded controls according to function.

Accessibility (hinged front and top panels expose all parts for service).

Sloping non-glare front for ease of control.

Write-in pads above mixing controls for input identification.

Cueing position on line input mixers.

Large skirted knobs for easy control.

Well spaced switches for fast operation.

Easy to install (terminal boards inside each end).

No back clearance needed (console can be serviced in place and in operation).

No cross-talk.

Tube testing facilities (push button switches on preamps and line amplifiers connect individual tubes with space current meter on face of console for checking).

Impossible to talkback to any studio having live microphones.

Plug-in 8 watt amplifier for monitoring at console and studios.

Switches and volume control for use with audition system.

Separate headset jacks for each channel.

Three separately fused power supplies (two in parallel for plate and filament voltages; one for relays and indicator lights both internal and external).

Complete patching panel for all line and utility inputs.

ACCESSORIES REQUIRED BUT NOT SUPPLIED WITH CONSOLE

W. E. P-2AA cords, one foot long equipped with 241A or 241B plugs for patching purposes.

High impedance headset (100,000 ohms) for headset monitoring.

Altec 633 type microphone for talkback purposes.

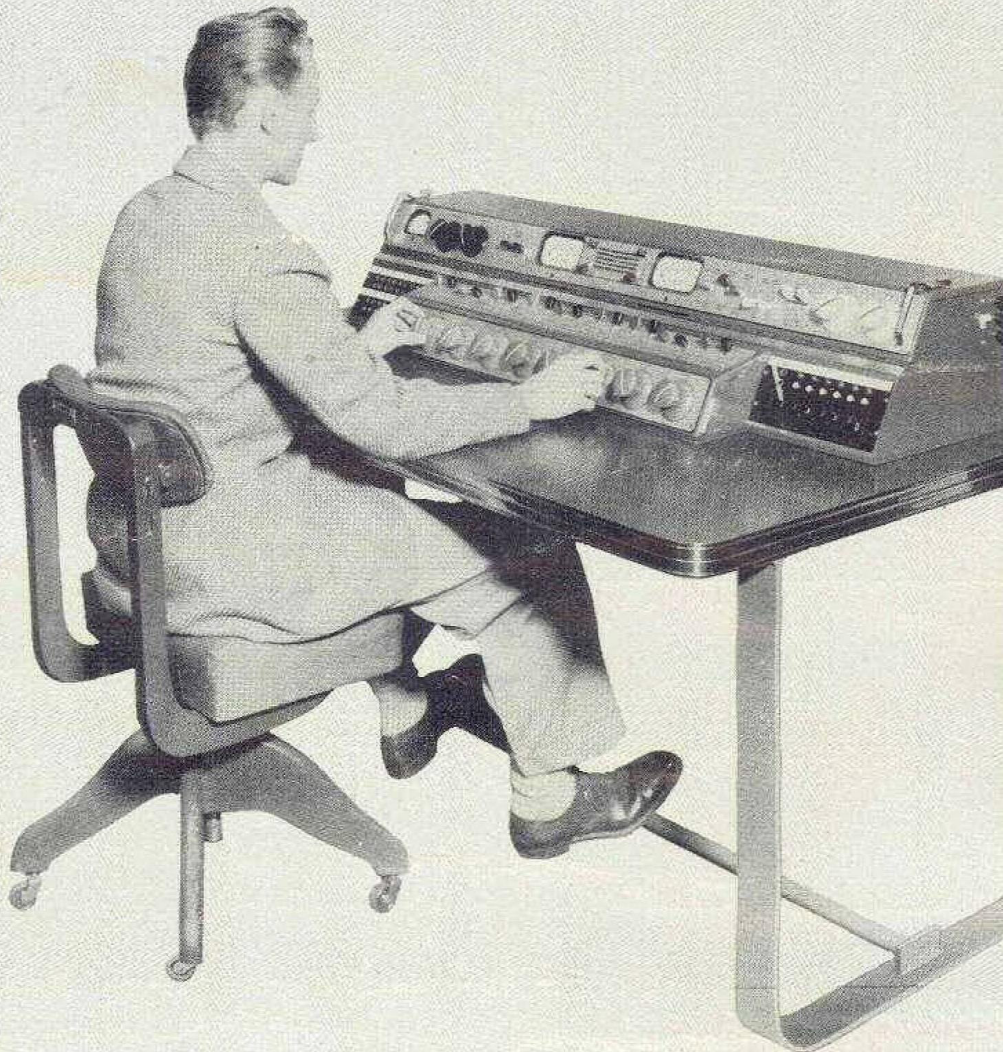

ALTEC
LANSING CORPORATION



250A
CONSOLE

technical data

*Unbalanced
line out?*

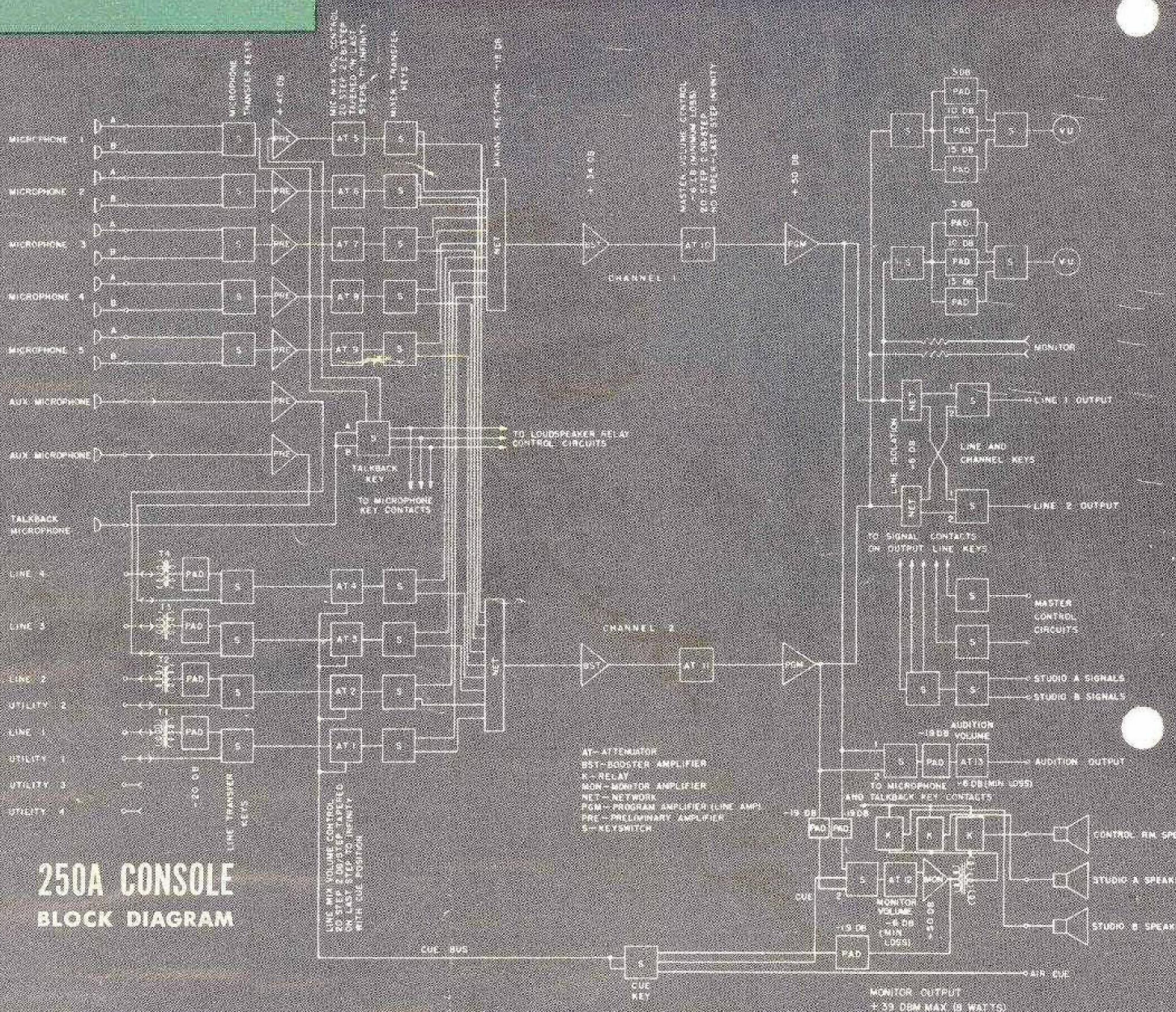

250A CONSOLE
BLOCK DIAGRAM

SIGNAL TO NOISE RATIO:	70 db.
SOURCE IMPEDANCES:	
Microphone Inputs	50, 150, 250 or 600 ohms
Line Inputs	600 ohms, nominal
Utility Inputs	600 ohms, nominal
Air Cue Input	600 ohms, nominal
LOAD IMPEDANCES:	
Line Outputs	600 ohms, nominal
Audition Output	600 ohms, nominal
Monitor Amplifier Outputs	Cue to line—600 ohms Loudspeaker—2-16 ohms
OVER-ALL GAINS:	
Microphone Inputs to Line Outputs	Approx. 94 db max. gain
Remote Line Inputs to Line Outputs	Approx. 34 db max. gain
Utility Inputs to Line Outputs	Approx. 54 db max. gain
Cue Input to Monitor Output Loudspeakers	Approx. 24 db. max. gain
Air Cue Line to Remote Line	Approx. 5 db. max. gain
SECTIONAL GAINS AND NETWORK LOSSES:	
Microphone Input to Mixer Input	40 db gain, max.

SECTIONAL GAINS AND NETWORK LOSSES: (continued)	
Line Input to Mixer Input	20 db loss, approx.
Utility Input to Mixer Input	0 db loss
Mixer Network Loss	Approx. 18 db (mixer volume control on minimum loss)
Mixer and Master Volume Controls (600 ohms to 600 ohms ladder type attenuator)	20 steps total; 34 db loss in steps of 2 db, then tapered to "infinity" in 3 steps (one of about 8 db and one of about 10 db and last step to off)
Mixer Output to Line Amplifier Output	78 db gain max.
Line Amplifier Output to Line Output (Network Loss)	6 db loss
POWER SUPPLY:	117 V., 50/60 cycles, 300 watts
WEIGHT:	280 pounds (including table)
DIMENSIONS:	Console cabinet—9½" high, 48" long, 16¾" deep Overall (including table)—36" high, 55" long, 31" deep Dark gray cabinet—light gray anodized escutcheon plates Green formica top table with chrome plated steel edging
FINISH:	

9536 Santa Monica Blvd., Beverly Hills, Calif.
161 Sixth Avenue, New York, New York



250A

ALTEC

LANSING CORPORATION

console...

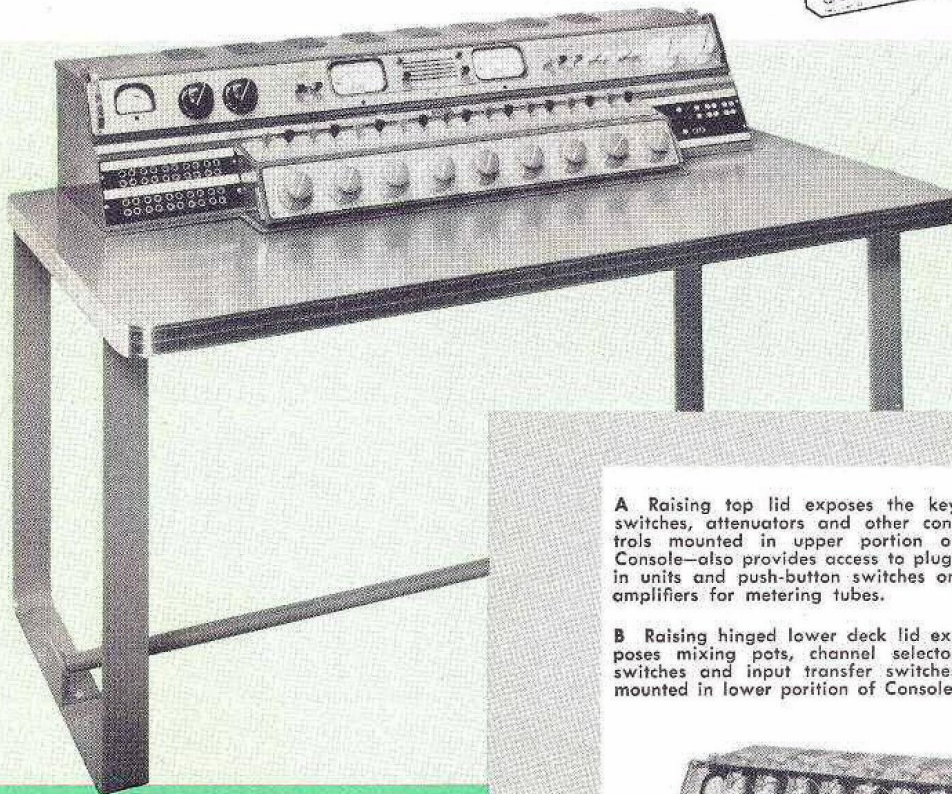

A Raising top lid exposes the key switches, attenuators and other controls mounted in upper portion of Console—also provides access to plug-in units and push-button switches on amplifiers for metering tubes.

B Raising hinged lower deck lid exposes mixing pots, channel selector switches and input transfer switches mounted in lower portion of Console.

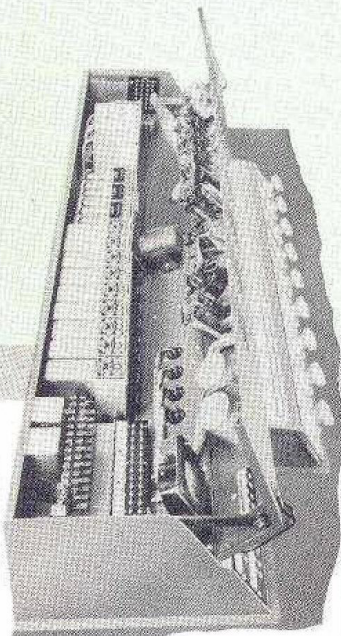

A

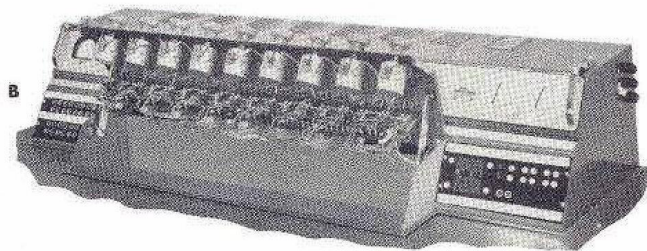

B

For the ultimate in quality control the new Altec 250A Console is the finest unit ever made for AM, FM or TV studio use. Its compactness, flexibility and accessibility are made possible by the use of newly designed miniature plug-in preamplifiers, line amplifiers and power supplies. The preamplifiers are only 1½" wide, 4¾" high and 10" long. The line amplifiers and power supplies are 2¼" x 4¼" x 10". The standard console contains five A-428B preamplifiers for microphone preamplification and two A-428B preamplifiers for boosters. There are provisions for two additional preamplifiers for increased microphone input facilities. There are three A-429B line amplifiers, two P-522B power supplies and one P-523B power supply. The 250A Console is neatly mounted in a 55" long green formica topped desk that leaves ample space for scripts, cueing sheets and notes. There are no external components to be hidden in the walls, placed in racks or stacked in the corner. The 250A is a completely self-contained AC operated program production console for the amplification, control and monitoring of programs from microphones, transcriptions, tape, remote inputs or other equivalent sources.

The 250A Console has nine mixing controls and 18 input channels. These inputs are connected to selection switches permitting the choice of either of two channels on each mixing control. As standard equipment five of the mixing controls are connected

with ten low level microphone inputs. Each of the other four mixers is connected to one line input and one utility input. This provides a total of ten microphone inputs, four line inputs and four utility inputs. Two of the line inputs can be converted for microphone use by plugging two extra preamplifiers into the wired receptacles provided in the console. These two preamplifiers must be purchased as extra equipment.

The output from each of the nine mixer controls can be switched to either of the two output channels. Each of these output channels has its own master mixing control, an illuminated VU meter and a phone jack for headset monitoring. Any of the inputs can be directed to either of these two output channels without fear of crosstalk or interference. There is also an independent channel for loudspeaker monitoring of either of the outputs, any of the incoming lines, or the cue circuits. This monitor channel may also be used to feed cue programs

back to the remote line circuits, or for talkback on either of the two studio loudspeaker circuits.

The console is wired to receive four 15036 line input repeating coils which are available as extra equipment and should be ordered separately. Provision has also been made for the connection of studio light and signalling control circuits. Connections are available for either an external talkback microphone or for one mounted behind the grille in the center of the console.

All controls are color coded according to function and grouped in the most efficient manner for sure convenient operation. The hinged face and top give complete access to every part of the console without the need of moving it from the wall. The wiring is simple and straightforward and terminal strips are located in both ends of the console for all permanent connections. The absence of external connection boxes or plugs eliminates the danger of accidental disconnection.

preamplifiers, line amplifiers & power supplies

Though designed primarily for use in the 250A Console, these new miniature plug-in preamplifiers, line amplifiers and power supplies are perfectly adaptable for custom type installations of speech input equipment. Each unit is supplied with a cover tray which can be permanently mounted in rack or cabinet. Part of this tray is the receptacle to which all connections are made. The

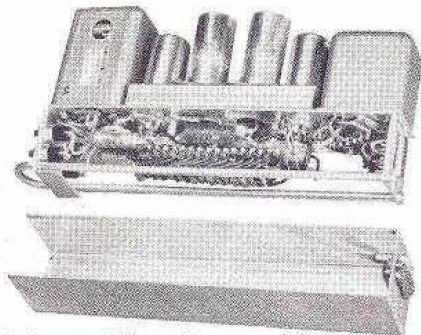

A-428B Preamplifier—(Removed from Cover Tray)*

(Showing open chassis design and plug-in connector of amplifier—and cover tray with mating receptacle.)

Gain	40 db (or 34 db with special connections in feedback circuit).
Source Impedance	50, 150, 300 or 600 ohms balanced.
Load Impedance	50, 150, 300 or 600 ohms balanced.
Frequency Response	±1 db from 20 to 20,000 c.p.s.
Output Level	+20 dbm with less than 1/2% total harmonic distortion from 50 to 15,000 c.p.s. and 1% total harmonic distortion from 30 to 15,000 c.p.s. Intermodulation distortion is less than 2% at +20 dbm output using 40 and 2,000 c.p.s. at 4 to 1 amplitude ratio, the output level being measured with an average reading meter.
Noise Level	Output noise level is equivalent to an input noise of -120 to -124 dbm, depending on input tube, with a 20,000 c.p.s. bandwidth. The input transformer has better than 90 db of magnetic shielding and has balanced windings to provide better than 50 db attenuation to longitudinal currents up to 45,000 c.p.s.
Tube Complement	2-12AY7.
Power Required	10 ma. at 260 VDC and 0.6 a. at 6.3 VAC. It is recommended that the AC filament supply be biased +20 to +70 VDC.
Size	10 in. long, 4 3/4 in. high and 1 1/2 in. wide (1 5/8 in. wide including cover tray).
Metering Circuits	Individual push-button switches connect the voltage developed across 5% resistors in the cathode circuit of each stage to a common metering circuit.

unit itself slides easily into the tray and by means of a guide pin, automatically centers its plug with the receptacle. This plug-in feature combined with the open design of the units leaves all parts readily accessible for service when removed from the tray. Another feature of the amplifiers is the push-button switches on the end of the chassis for use in individual tube testing.

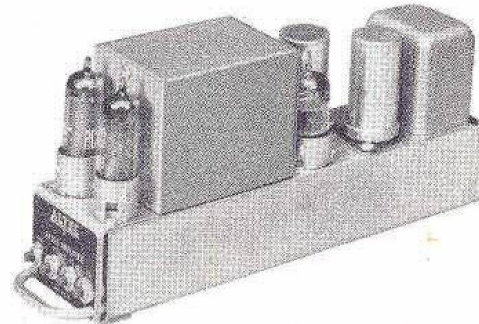

A-429B Line or Monitor Amplifier—(Encased in Cover Tray)**

(Showing push-button switches used for tube metering.)

Gain	50 db.
Source Impedance	50, 150, 300 or 600 ohms balanced.
Load Impedance	150 or 600 ohms balanced.
Frequency Response	±1 db from 20 to 20,000 c.p.s.
Output Level	+30 dbm with less than 1/2% total harmonic distortion from 30 to 15,000 c.p.s. as a line amplifier, and +39 dbm (8 watts) at less than 1% total harmonic distortion from 50 to 15,000 c.p.s. as a monitor amplifier. Intermodulation distortion is less than 2% at +29 dbm output as line amplifier and less than 4% at +37 dbm as monitor amplifier using 40 and 2,000 c.p.s. at a 4 to 1 amplitude ratio, the output level being measured with an average reading meter.
Noise Level	Output noise level is equivalent to an input noise of less than -110 db with a 20,000 c.p.s. bandwidth. Input transformer shielding and longitudinal current balance are the same as for the A-428B preamplifier.
Tube Complement	1-12AY7, 2-6AQ5.
Power Required	75 ma. at 270 VDC and 1.2 a. at 6.3 VAC as a monitor amplifier (plate current measured with zero signal—approximately 90 ma. is required for a +39 dbm output), and 38 ma. at 270 VDC and 1.2 a. at 6.3 VAC as a line amplifier. When used as a line amplifier, an external dropping resistor is required to reduce voltage at the plates of the output tubes.
Size	10 in. long, 4 3/4 in. high and 2 1/4 in. wide (2 3/8 in. wide including cover tray).
Metering Circuits	Tube metering provisions are the same as for the A-428B preamplifier.

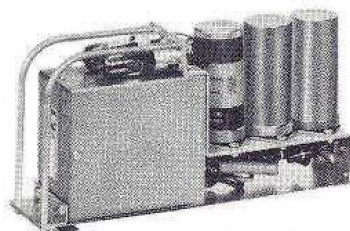

P-522B Power Supply—(Less Cover Tray)

(Provides plate and filament voltage for amplifiers.)

Input Power	Approximately 80 watts at 117 V., 60 c.p.s. AC with full load.
Output Power	135 ma. at 270 VDC, or 95 ma. at 270 VDC and 40 ma. at 260 VDC. 5.0 a. at 6.3 VAC biased +65 VDC. The 260 V. output has 3 more stages of filtering than the 270 V. output. The power supply will accommodate combinations of A-428B and A-429B amplifiers drawing a maximum of 135 ma. total of both 270 V. and 260 V. outputs. The A-429B amplifiers must be supplied from the 270 V. output, using an external dropping resistor of about 3,500 ohms for line amplifier operation of the A-429B.
Output Ripple	0.2 V. r.m.s. on 270 volt output when delivering 135 ma. total current to load, and less than .001 volt r.m.s. on 260 volt output when delivering 40 ma. to load.
Tube Complement	2-6X4.
Size	10 in. long, 4 1/4 in. high and 2 1/4 in. wide (2 3/8 in. wide including cover tray).

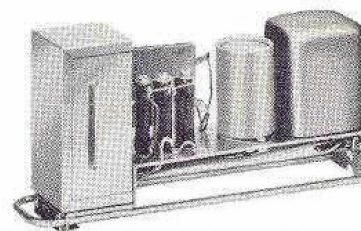

P-523B Power Supply—(Less Cover Tray)

(Provides voltage for relays and signal lamps. Contains three loudspeaker muting relays.)

Input Power	Approximately 20 watts at 117 V., 60 c.p.s. AC with full load.
Output Power	1.2 a. at 12 VDC. When the relays contained in the power supply are in operation, the available output current is 1 ampere maximum. A selenium rectifier is used.
Size	10 in. long, 4 1/4 in. high and 2 1/4 in. wide (2 3/8 in. wide including cover tray).

MOUNTING ACCESSORIES

- 11301 Assembly*** Consists of a cover tray with guide pin and mating Cannon DA-15-335 receptacle for A-428B preamplifier.
- 11302 Assembly**** Consists of cover tray with guide pin and mating Cannon DA-15-335 receptacle for A-429B amplifier or P-522B and P-523B power supplies.

*As shown with A-428B preamplifier.

**As shown housing A-429B line amplifier.

outstanding features

250A
CONSOLE

Plug-in preamplifiers, line amplifiers and power supplies (for easy service and instant replacement).
Open chassis design on preamplifiers, amplifiers and power supplies (for ease of test and repair).
Wide range frequency response (± 1 db 20-20,000 cycles).

Very low distortion... Very low noise level.

18 inputs.

Up to twelve balanced line microphone inputs (mix 7 simultaneously).

Excellent balance—high attenuation of longitudinal currents for all frequencies up to 20,000 cycles.

4 line inputs, 4 utility inputs for turntable, etc. (mix 4 simultaneously).

2 channel 2 line output operation. Switch channels to either line instantly.

Flush mounted illuminated 4" VU meters, one for each channel.

VU meter cut-off switches and three position attenuators.

Self-contained (no external power supplies, etc.).

Compact (only 36" x 31" x 55" including desk).

Operator designed (the right height and the right size).

Color coded controls according to function.

Accessibility (hinged front and top panels expose all parts for service).

Sloping non-glare front for ease of control.

Write-in pads above mixing controls for input identification.

Cueing position on line input mixers.

Large skirted knobs for easy control.

Well spaced switches for fast operation.

Easy to install (terminal boards inside each end).

No back clearance needed (console can be serviced in place and in operation).

No cross-talk.

Tube testing facilities (push button switches on preamps and line amplifiers connect individual tubes with space current meter on face of console for checking).

Impossible to talkback to any studio having live microphones.

Plug-in 8 watt amplifier for monitoring at console and studios.

Nonlocking talkback key

Switches and volume control for use with audition system.

Separate headset jacks for each channel.

Three separately fused power supplies (two in parallel for plate and filament voltages; one for relays and indicator lights both internal and external).

Complete patching panel for all line and utility inputs.

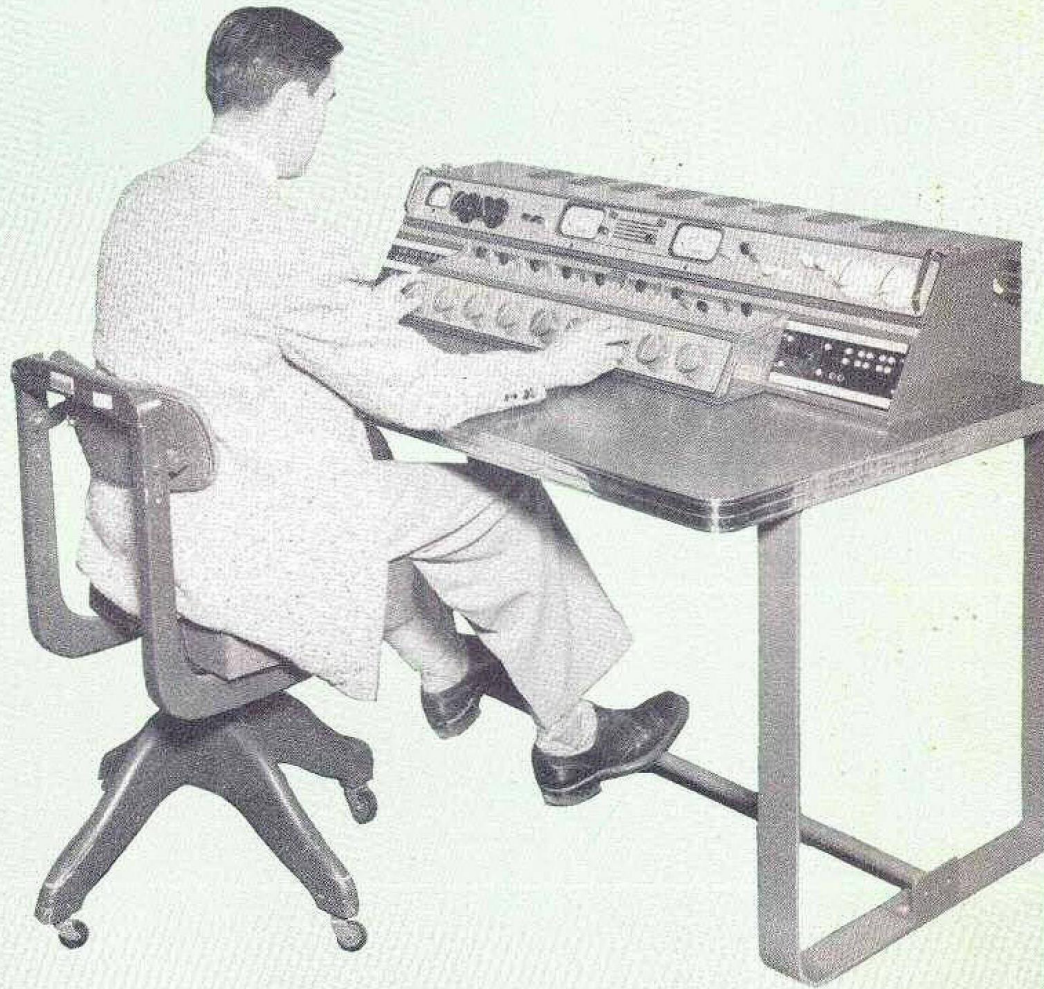

ACCESSORIES NOT SUPPLIED WITH CONSOLE

W. E. P-2AA cords, one foot long equipped with 241A or 241B plugs for patching purposes.

High impedance headset (100,000 ohms) for headset monitoring.

Altec 633 type microphone for talkback purposes.

Altec 15036 Repeat Coil

Distributed by Graybar Electric Co.

ALTEC
LANSING CORPORATION

Distributed by
Graybar

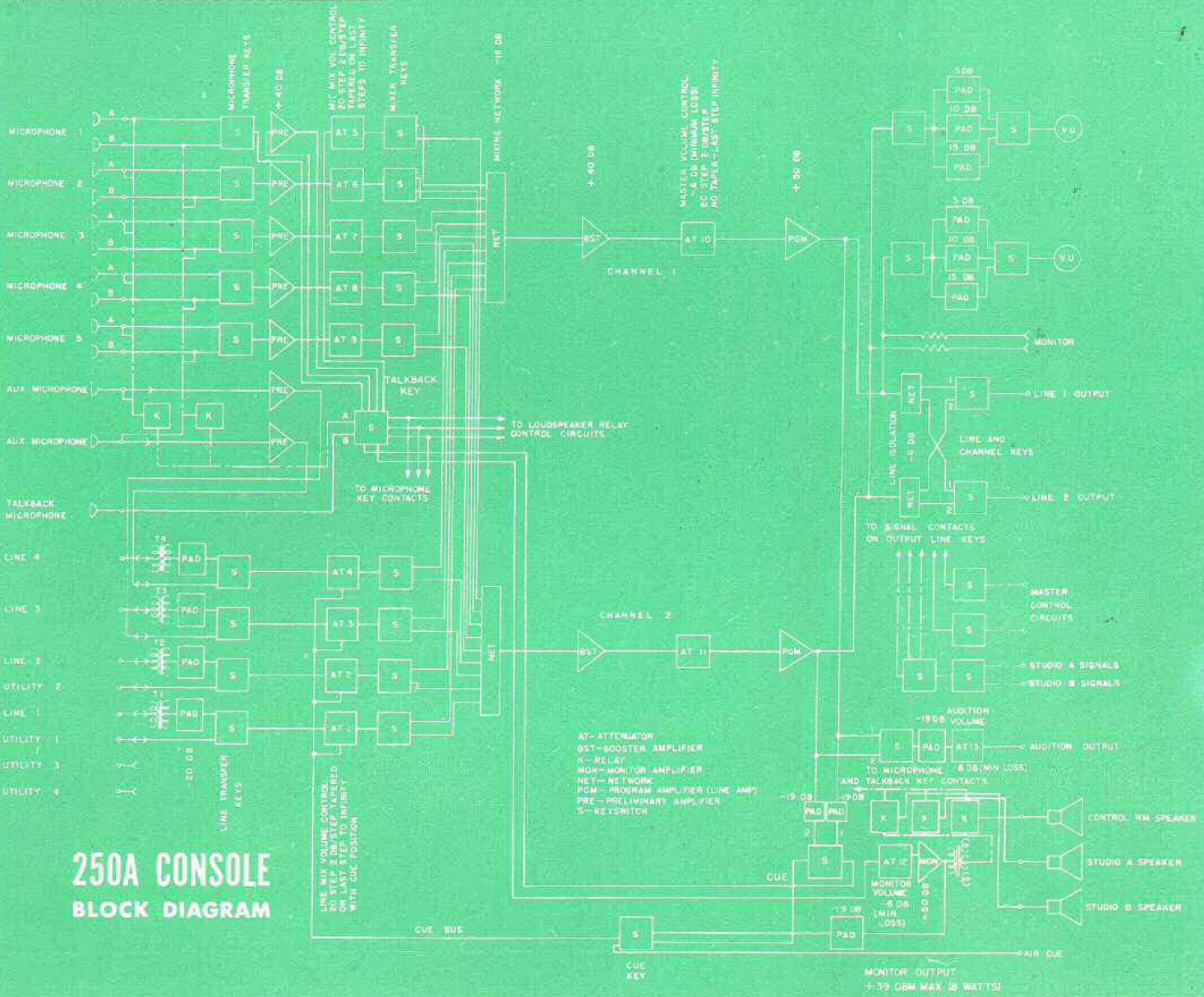

250A CONSOLE
BLOCK DIAGRAM

SIGNAL TO NOISE RATIO:	70 db
SOURCE IMPEDANCES:	
Microphone Inputs	50, 150, 300 or 600 ohms
Line Inputs	600 ohms, nominal
Utility Inputs	600 ohms, nominal
Air Cue Input	600 ohms, nominal
LOAD IMPEDANCES:	
Line Outputs	600 ohms, nominal
Audition Output	600 ohms, nominal
Monitor Amplifier Outputs	Cue to line—600 ohms; Loudspeaker—2-16 ohms
OVER-ALL GAINS:	
Microphone Inputs to Line Outputs	Approx. 100 db max. gain
Remote Line Inputs to Line Outputs	Approx. 40 db max. gain
Utility Inputs to Line Outputs	Approx. 60 db max. gain (20 db pad installed)
Cue Input to Monitor Output Loudspeakers	Approx. 24 db max. gain
Air Cue Line to Remote Line	Approx. 5 db max. gain
SECTIONAL GAINS AND NETWORK LOSSES:	
Microphone Input to Mixer Input	40 db gain, max.

SECTIONAL GAINS AND NETWORK LOSSES: (continued)

Line Input to Mixer Input	20 db loss, approx.
Utility Input to Mixer Input	0 db loss
Mixer Network Loss	Approx. 18 db (mixer volume control on minimum loss)
Mixer Controls (600 ohms to 600 ohms ladder type attenuator)	20 steps total; 34 db loss in steps of 2 db, then tapered to "infinity" in 3 steps (one of about 8 db and one of about 10 db and last step to off)
Mixer Output to Line Amplifier Output	84 db gain max.
Line Amplifier Output to Line Output (Network Loss)	6 db loss
POWER SUPPLY:	117 V., 50/60 cycles, 200 watts
WEIGHT:	280 pounds (including table)
DIMENSIONS:	Console cabinet — 9 1/2" high, 48" long, 16 3/4" deep Over-all (including table) — 36" high, 55" long, 31" deep Dark gray cabinet — light gray anodized escutcheon plates Green formica top table with chrome plated steel edging
FINISH:	

1957



Console

★230B★

COLOR CODED CONTROLS

ACCESSIBLE

COMPACT

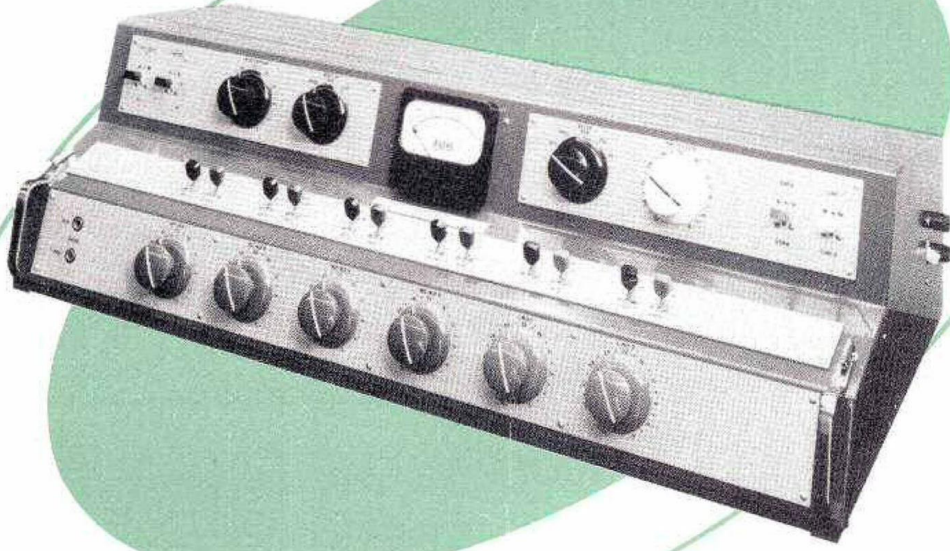

?
4-4284 Prelim
2-5074
1-6A&5
2-4274 Boost
1-4274 L.A.

SELF CONTAINED

The new Altec 230B Console is designed for small station and single studio use and two or more are often ideal in even the largest application. Its quality exceeds FCC standards and generous safety factors assure the continuance of quality and long operation without need for service or repair. Like other Altec consoles the 230B has been carefully engineered to do the largest job in the least space. Its flexibility and the careful placement and color-coding of the mixing knobs and control switches make the operation of the 230B a pleasure. The controls are logically grouped and properly spaced for the fastest possible operation without fear of mistakes. Height of the new console has been kept to a minimum so it will not interfere with vision when placed against a window separating the control room from the studio.

The front panel of the 230B hinges upward to expose all of the mixing pots, switches and tubes for immediate service. The preamplifiers, booster amplifiers, line amplifier and monitor amplifier are all mounted on a hinged sub assembly. The two plug-in power supplies are mounted on the floor of the console where they may be removed for complete servicing or instant replacement.

Four of the six mixing controls on the console are connected with eight low level microphone or turntable inputs. The other two are connected with four line inputs giving a total of twelve inputs and any six can be mixed simultaneously. The output channel can be switched to either of two output lines automatically connecting the control room telephone to the unused line.

The built-in talk back circuits are carefully interlocked to prevent program interruption and to avoid any possibility of feedback. The monitor amplifier, usually used for talk back and for audition or public address, can instantly replace the line amplifier in case of emergency simply by throwing the emergency amplifier switch on the face on the console. The large illuminated VU meter can be switched to meter the program output channel, monitor or remote lines and the plate and relay supply voltages. Each of the line input mixer controls has a cueing position.

The 230B Console is unique in its many desirable features and flexibility. It is perfectly suited for the less complex broadcasting stations, for single studio use in large studios and for use in elaborate P.A. and recording installations.



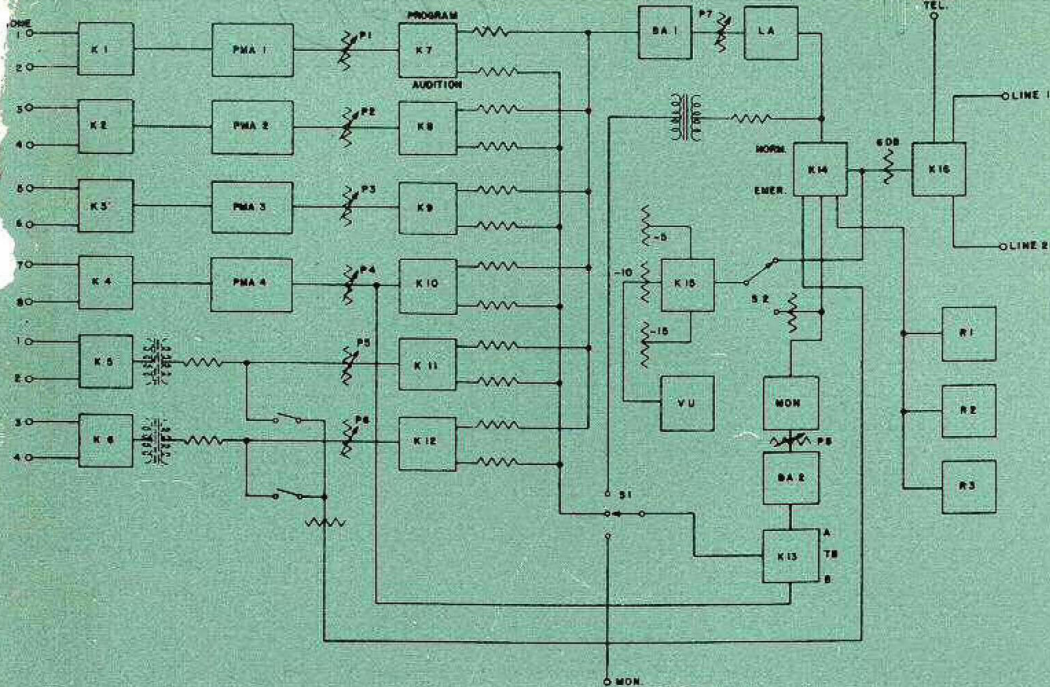

230B Console

Technical Data...

GAIN:

Maximum microphone to program line:
100 db (includes 6 db isolation pad)

FREQUENCY RESPONSE:

Microphone to line: ± 1 db, 20 to 20,000 cycles.

Microphone to monitor speaker: ± 1 db, 20 to 15,000 cycles.

NOISE LEVEL:

74 db below + 24 dbm from microphone input to program line with 70 db net gain.

69 db below + 39 dbm from microphone to monitor output line with 90 db net gain.

SOURCE IMPEDANCES:

Microphones: 50, 150, 300 or 600 ohms.

Line Inputs: 600 ohms (150 or 600 ohms with optional repeat coil).

OUTPUT IMPEDANCE

Program Line: 500/600 ohms balanced

Monitor Amplifier: 500/600 ohms balanced (may be strapped for 150 ohms).

DISTORTION:

Program Circuit: Less than 1% from 50-15,000 cycles at + 24 dbm line level.

Monitor Circuits: Less than 1% from 50-15,000 cycles at + 39 dbm line level.

OUTPUT LEVEL:

Program Line: + 24 dbm maximum (with 6 db line pad)

Monitor Line: 8 watts at 1% harmonic distortion, 50-15,000 cycles.

TUBES:

Amplifiers: 10-5879; 4-6 AQ5.

P-522A Power Supply: 2-6X4.

POWER INPUT:

115/125 volts, 50-60 cycles AC, 1.0 amp.

WEIGHT:

Approximately 80 pounds.

DIMENSIONS:

36 $\frac{1}{2}$ " wide, 9 $\frac{3}{8}$ " high and 17" deep.

FINISH:

Dark gray housing—anodized light gray escutcheon plates.

NOTE DBM:

Reference level 1 mw, 600 ohms.

Outstanding Features...

Eight low level microphone or turntable inputs (mix four simultaneously).

Four remote line inputs (mix two simultaneously).

Color coded knobs for accurate control.

Built-in cueing circuit on line mixer controls.

Emergency amplifier switch (instantly replaces line amplifier with monitor).

Wide range frequency response (± 1 db 20-20,000 cycles).

Very low distortion.

Very low noise level.

Headset jacks for program channel and remote line inputs.

Large illuminated VU meter.

Accessibility (all components exposed without moving console from operating position).

Plug-in power supplies.

Interlocked talk back circuits (no program interruption or feed-back).

Low height for maximum studio visibility.

Completely self contained (no external power supplies, etc.).

Compact (only 17" x 9 $\frac{3}{8}$ " x 36 $\frac{1}{4}$ ").

Monitor amplifier can be switched to audition, program or external input.

230B and 250A Consoles

230B
250A

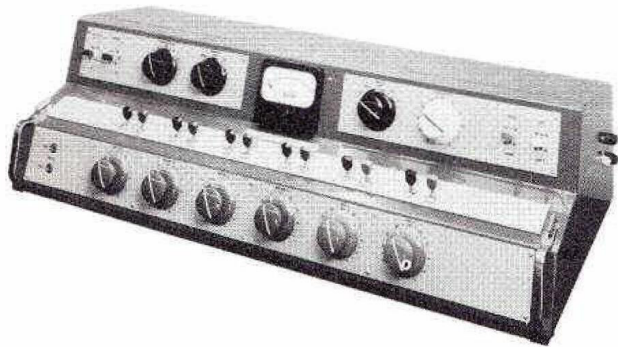

230B Console

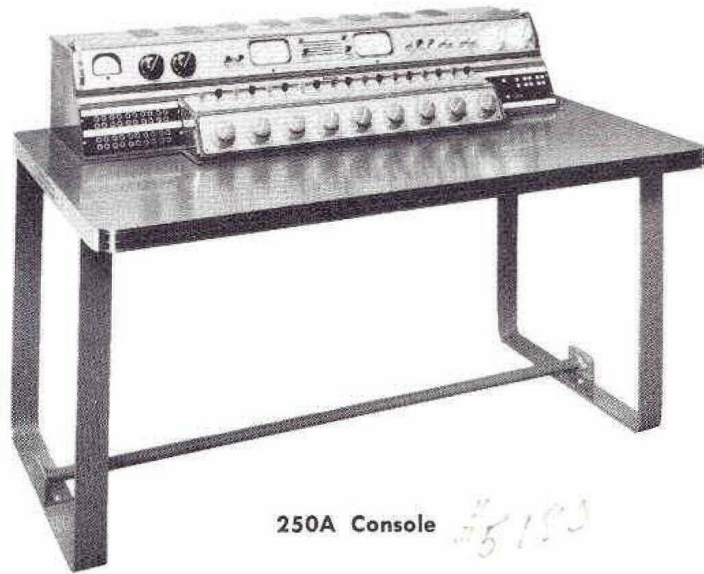

250A Console

230B CONSOLE

The 230B Console exceeds F.C.C. Standards of quality and has generous safety factors to insure long life and reliability. With its compactness and low height it does not interfere with vision when placed between the control room and the studio. The color-coded mixing knobs and controls are logically grouped and properly spaced for the fastest possible operation. The hinged front panel permits fast servicing of mixing pots, switches and tubes, and immediate access to the plug-in power supplies. Eight low level microphone or turntable inputs are controlled by four mixing knobs. The other two knobs control

four line inputs thus providing a control of twelve inputs with facilities for mixing six at any one time. The output channel can be switched to either of two output lines and automatically connects the control room telephone to the unused line. The eight watt monitor amplifier normally used for talk-back and public address can be instantly switched to replace the line amplifier in case of emergency. The large VU meter monitors the program output channel, remote lines, or the plate supply and relay supply voltages. Cue in circuits are provided on the line input controls. The 230B Console is completely self-contained.

SPECIFICATIONS

Gain:	100 db, microphone inputs; 45 db, line-level inputs
Power Output:	+20 dbm at 1/2% thd, 30-15,000 cps +24 dbm at 1% thd, 30-15,000 cps
Frequency Response:	± 1 db, 20-20,000 cps, any input to program output
Source Impedance:	30/50, 125/150, 250/300, 500/600 ohms, mic. inputs 600 ohms, line level inputs (150 or 600 ohms if repeat coils are used)
Load Impedance:	150 or 600 ohms, line outputs 2, 4, 8, 16 ohms, loudspeaker outputs
Noise Level:	74 db below +24 dbm (mixer and master controls adjusted for 70 db net gain)— Equivalent input noise —120 dbm
Controls:	4 mic. mixers, 2 line-level mixers, monitor & program master gain controls. Complete input keying, talkback, monitor & audition facilities.
Power Supply:	117 volts, 60 cps, 100 watts
External Power Available:	12 vdc for relay operation
Tubes:	10—5879, 4—6AQ5, 2—6X4
Dimensions:	9 3/4" H, 36 1/4" W, 18" D
Color:	Blue gray
Weight:	90 lbs.
Special Features:	All amplifiers, power supplies and loudspeaker relays are contained within the 230B Console. 8 watt monitor amplifier is provided. Illuminated 4 1/2" V.U. meter. Provision for 8 mic. and 4 line-level inputs, 2 separate output lines, 3 separate loudspeaker lines.



1515 S. Manchester Ave., Anaheim, Calif.

New York, Los Angeles

250A CONSOLE

The handsomely compact 250A Console contains the following plug-in units: five 428B Preamplifiers for microphone preamplification, two 428B Preamplifiers for boosters, two 429B Line Amplifiers, and one 429B 8 watt monitor amplifier, two 522B Power Supplies, and one 523B Power Supply. These provide a total of nine mixing controls and eighteen input channels. As equipped, five of the mixing controls connect with ten low level microphone inputs. Each of the other four mixers connect to one line input and one utility input. Two of these line inputs can be converted for microphone use by the insertion of two extra 428B Preamplifiers in the pre-wired receptacles. These two extra 428B Preamplifiers must be ordered separately. The output of any of the mixer controls

can be switched to either of two output channels. Each output channel has its own master mixing control and illuminated VU meter and a phone jack for headset monitoring. In addition, an independent channel for loudspeaker monitoring of either output, any of the incoming lines, or the cue circuits, is provided. This channel may also be used to feed cue programs back to the remote line circuits or for talk-back, or either of the two studio loudspeaker circuits. The console is wired for four 15036 line input repeating coils which must be ordered separately as extra equipment. All controls are color coded according to function and placed for most efficient and convenient operation. The hinged top and face of the console provides immediate access to all parts. Tube checking facilities are provided. The 250A Console is completely self-contained.

SPECIFICATIONS

Gain:	100 db, microphone inputs: 60 db, utility inputs: 40 db, remote line inputs
Power Output:	+20 dbm at less than ½% thd, 30-15,000 cps +24 dbm at less than 1% thd, 30-15,000 cps
Frequency Response:	± 1 db, 30-15,000 cps
Source Impedance:	30/50, 125/150, 250/300, 500/600 ohms, mic. inputs. 600 ohms all other inputs (150 or 600 ohms when repeat coils are installed)
Load Impedance:	600 ohms, line, audition or cueing outputs 2, 4, 8, 16 ohms, loudspeaker outputs
Noise Level:	70 db below +18 dbm output (mixer and master controls adjusted for 68 db net gain)
Controls:	5 mic. mixers, 4 line mixers, 2 master gain controls, audition & monitor gain controls. Complete input keying, talkback, monitor, audition, cueing and line switching facilities.
Power Supply:	117 volts, 60 cps, 200 watts
External Power Available:	12 vdc for relay operation
Tubes:	17-12AY7, 6-6AQ5, 4-6X4
Dimensions:	8½" H, 48" W, 17" D above table top; table 55" x 32" x 27" high
Color:	Console: blue gray; table top: dark green
Weight:	Console and table: 280 lbs.
Special Features:	All amplifiers and power supplies are self-contained, plug-in type. Uses 428B and 429B amplifiers. Two line input channels are wired to accept additional preamplifiers which must be ordered separately. Contains 8 watt monitor amplifier, 2-4½" illuminated V.U. meters, and two line amplifiers. Normally used for two-studio operation. Two separate programs may be transmitted simultaneously.

ACCESSORIES

See Catalog Sheet AL-1420-1 for complete information on 522B and 523B Plug-in Power Supplies and AL-1422-1 on 428B and 429B Plug-in Amplifiers.

250 SU CONTROL CONSOLE

250SU

FOR ALL STEREO AND UNIVERSAL OPERATING FUNCTIONS

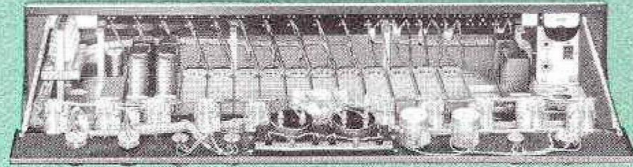
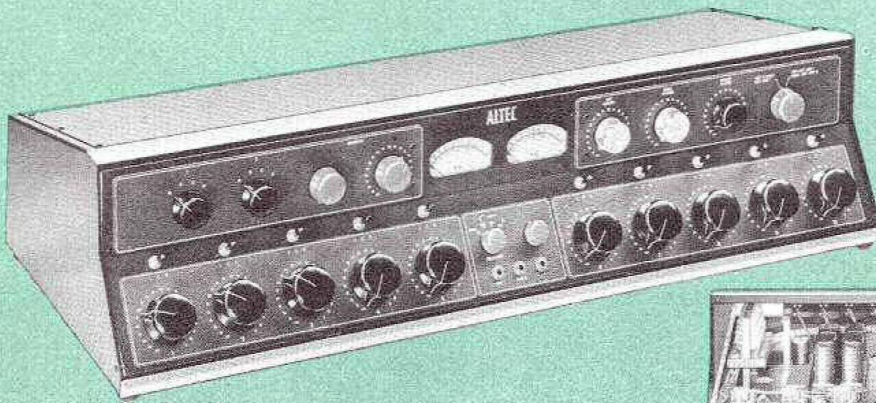

250 SU CONSOLE

The ultimate in product design and product usage is embodied in the new 250 SU Altec Control Console. This unit is the finest ever built for TV, AM, FM, Recording Studio or Sound System use. The 250 SU is a compact console providing the greatest flexibility attainable in mode of operation. This extreme flexibility is made possible by the use of newly designed miniature plug-in preamplifiers, program amplifiers, and utility input devices. The plug-in units are only $1\frac{5}{8}$ " wide, $3\frac{13}{16}$ " max. high and $9\frac{9}{16}$ " long, over handle. All units are the same in size to permit flexibility in the number and type of amplifiers used per console.

Single unit construction, namely amplifiers and controls in the same housing, is used because of simplified, less expensive installation. The power supply of any Control Console is always a potential source of undesirable hum inducing flux fields, and is, therefore, mounted external to the console. To keep the installation of the power supply simple, it is built into a separate housing, which may be mounted to the underside of a table, the table leg, or on an adjoining wall. A single screw frees the power supply unit from its mounting bracket for inspection. The model 535A Power Supply is furnished with a 4 foot interconnecting cable with plug for connection to the mating receptacles inside the console. The 250 SU Console requires no special table or mounting facilities as all leads terminate at "strips" located inside the console housing.

There are ten input positions and each is equipped with "bus" switches and mixer attenuators. Any input position may be used for EITHER high level or low level sources by inserting the proper input device. It is only necessary to order the number of microphone preamplifiers and/or utility input devices that is required for the particular installation. Mounting trays for the maximum of plug-in units are, however, installed and wired.

All output circuitry for single-channel, single-line, two-channel, two-line, dual stereo or three channel/two channel stereo is included and wired. It is only necessary to plug in the necessary number of amplifiers to provide the desired functions.

Three channel/two channel operation consists of using the center position of the "bus" selector key to feed a third or "center channel" mixing "bus." The output of the "bus" is amplified, then divided by means of a splitting pad and introduced into the left and right channels. For "stereo" use, this permits vocal or dialogue material to be picked up on a single microphone and evenly divided to the left and right channels without problems of balance, microphone matching, etc. In this case, the variable dialogue (speech) filter is connected in the center channel.

Splitting the center channel to left and right is also used in re-recording where the master tape is recorded full three channel then reduced to two channels for the release tape or disc.

Monitor amplifiers are not included as part of the console as small eight watt units frequently used for this purpose are inadequate with many current low efficiency speakers. Standard Altec amplifiers such as model 128A and 350A are recommended, mounted on a shelf or in a standard equipment cabinet.

A terminal strip has been provided in the console to which all major circuits connect. The purpose of this terminal is to allow these circuits to be "wired out" to an auxiliary equipment cabinet for the inclusion of jack strips, equalizers or other secondary equipment which may be required in the particular installation.

The center control panel contains a spare phone jack in addition to the two monitor jacks for use with an "intercom" system. This panel also contains a spare rotary selector switch. The panel marking process is such that additional characters for the spare selector and jack may be engraved with the desired designations and filled with "whiting" providing a proper match with the existing lettering.



A Subsidiary of Ling-Temco Electronics, Inc.

1515 S. Manchester Ave., Anaheim, Calif.

New York, Los Angeles

Preamplifiers, program amplifiers, power supplies & accessories

Though designed primarily for use in the 250 SU Altec Control Console, these new miniature "plug-in" preamplifiers, program amplifiers, utility input device, power supply and meter assemblies are perfectly adaptable for rack mounting of speech input equipment for custom type installations. Rack mounting facilities are available for this use. These amplifiers will accept input level up to -15 dbm without exceeding 1% THD.

The dynamic range of 459A Program Amplifiers is equivalent to model 458A Preamplifier (see noise level specifications) making it suitable for preamplifier use where added channel gain is required. Mounting tray assemblies and plug-in connections are identical on all input devices. Part of the Mounting Tray Assembly is a miniature receptacle to which all connections are made. This receptacle "mates" with the plug on the amplifier and utility input devices. This "plug-in" feature combined with the uncrowded positioning of all components leaves all parts readily accessible when removed from the mounting tray.

458A PREAMPLIFIER

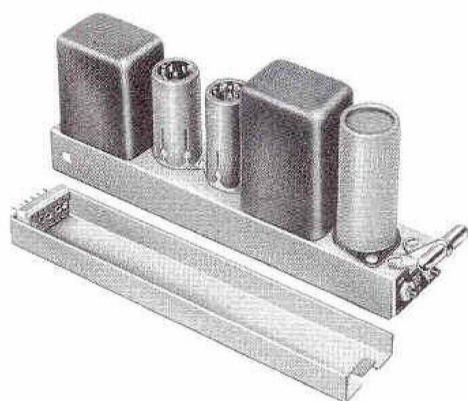

SPECIFICATIONS:

Gain:	40 db unterminated input, 34 db terminated.
Power Output:	+20 dbm at less than .5% THD 50 to 15,000 cps. +25 dbm at less than 1% THD at 1 KC.
Frequency Response:	± 1 db 20 to 20,000 cps.
Source Impedance:	150 or 600 ohms (centertap available when connected for 600 ohms).
Load Impedance:	150 to 600 ohms (centertap available when connected for 600 ohms).
Output Impedance:	Equal to load impedance.
Noise Level:	Equivalent input noise: -126 dbm (valid for unterminated input operation).
Power Supply:	15ma at 275vdc and .7a at 6.3vdc.
Tubes:	2—6072/12AY7.
Dimensions:	1 $\frac{3}{4}$ " W x 3 $\frac{15}{16}$ " H and 9 $\frac{1}{16}$ " L when mounted in tray.
Color:	Cadmium plate with dichromate dip
Weight:	3 $\frac{1}{2}$ lbs. (including tray).
Special Features:	Push buttons for individual tube test. 40ma dc can be applied to input or output transformer center taps for simplexing use.
Accessories:	13225 Rack Mounting Assembly (accommodates 9 units). 13401 Mounting Tray Assembly. 5981 Tube Test Meter. 535A Power Supply.

459A PROGRAM AMPLIFIER

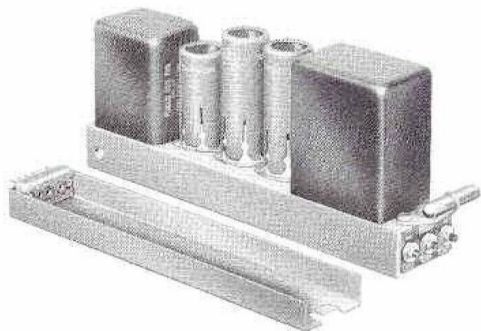

SPECIFICATIONS:

Gain:	56 db unterminated input, 50 db terminated.
Power Output:	+30 dbm at less than .5% THD 30 to 20,000 cps. +35 dbm at less than 1% THD at 1 KC.
Frequency Response:	± 1 db 20 to 20,000 cps.
Source Impedance:	150 or 600 ohms (centertap available when connected for 600 ohms).
Load Impedance:	150 or 600 ohms (centertap available when connected for 600 ohms).
Noise Level:	Equivalent input noise: -126 dbm (valid for unterminated input operation).
Power Supply:	40ma at 275vdc and 1.6a at 6.3vdc.
Tubes:	1—6072/12AY7, 2—12BH7.
Dimensions:	1 $\frac{3}{4}$ " W x 3 $\frac{15}{16}$ " H x 9 $\frac{1}{16}$ " L when mounted in tray.
Color:	Cadmium plate with dichromate dip
Weight:	3 $\frac{1}{2}$ lbs. (including tray).
Special Features:	Push buttons for individual tube test. 40ma dc can be applied to input or output transformer centertaps for simplexing use.
Accessories:	13225 Rack Mounting Assembly (accommodates 9 units). 13401 Mounting Tray Assembly. 5981 Tube Test Meter. 535A Power Supply.

535A POWER SUPPLY



SPECIFICATIONS:

Power Output:	275vdc at 275ma. At 275ma ripple is .02v peak to peak max. 6.3vdc at 13a. At 13a ripple is 1.5v peak to peak max.
Power Input:	117v 50-60 cps 245 watts at full load.
Rectifiers:	Silicon.
Controls:	1. Power Switch 2. Circuit Breaker (Push to reset) 3. 4 position tap switch (provides adjustment of voltage by autotransformer action to accommodate 2 to 1 range of loads).
Color:	Dark Green.
Weight:	16 pounds.
Size and Mounting:	7 $\frac{3}{16}$ " W x 9 $\frac{5}{8}$ " H x 7" D overall.

VISUAL ELECTRONICS CORP.

356 WEST 40TH STREET
NEW YORK 18 NEW YORK
PENNSYLVANIA 6-5840

product news

By co
comp

1. 250 SU Basic
2. 535A Power
3. 458A Preamplifier
(a) One for €
(b) One for €
4. 459A Program
One for singl
channel/two
5. 13387 Utility
One for each
6. 7160 V.U. M
For second ch
7. 5981 Tube Te
8. Altec Monitor
Use as separa

Keeps You in View

ATTENTION MR. BROADCASTER:

The attached descriptive material relative to the new ALTEC 250 SU CONSOLE is important to anyone interested in consoles - -

Preamplifiers, I

The 7160 V. U. Meter is an exact duplicate of the 250 SU Altec Control Console, and the meter furnished. Meter illumination and pads are part of the 250 SU Console. Required for installation or connection required for "stereo" or two-channel/

The 13387 unit is a Utility Input Device. This is an isolation transformer built of the same size and dimensions as the 458A Altec designed for insertion into the standard Type 13387 is for "bridging" a 150,000 ohm line. The unit is cadmium plated and weighs 1 pound.

The 5981 Tube Test Meter is an accessory Console unit. It is used to visually test tube connections and wiring for the meter are in the right rear section. No special tools are required. When installed, the meter provides, in addition, a push button switch. The meter is a standard part of the console.

RACK MOUNTING

The 13225 is available for use in rack mounting. The rack mounting assembly is designed for use with Amplifiers and Altec 13387 Utility Input Device. The 13225 assembly is for standard rack mounting and occupies only 5 1/4" of space. It has a "Snap-in" removable front cover for inspection for test or service. The finish of the front cover is chrome. The complete assembly weighs 4 pounds. For rack mounting 535A Power Supply, 10440 10 may be used or Power Supply may be mounted on wall

The 13401 is furnished as part of the 250 SU Console, however, it is available separately to provide mounting connection facilities for 458A and 459A Altec "Preamplifiers" and the 13387 Utility Input Device, when mounted in the Rack Mounting Assembly. The 13401 finish is cadmium plate. The tray assembly is complete with "mating" female terminals for the 458A, 459A and 13387 units. The tray measures 9" L (over terminals), and weighs 1/2 pound.

Completely versatile and adaptable to your most exacting use, including TWO and THREE CHANNEL STEREO

No need to buy more console than you need

ALTEC QUALITY - for professional operation

Immediate delivery at present

The following prices apply:

250SU	Basic Console	\$1,200.00
458A	Pre Amplifier	143.00
459A	Program Amplifier	158.00
535A	Power Supply	158.00
7160	VU Meter	30.00
5981	Tube Test Meter	18.00
13387	Utility Input Device	32.00
13225	Rack Mounting Assembly	17.00
13401	Tray	12.00
128A	Amplifier, 30 watt	260.00

Contact your VISUAL man!

planning information

By completing the form below, the purchaser is assured of ordering the full complement of components to provide all facilities for the particular console.

ITEM	QUANTITY
1. 250 SU Basic Altec Console	1
2. 535A Power Supply	1
3. 458A Preamplifiers	
(a) One for each microphone or low level input (10 max.)	
(b) One for each channel (3 max.)	
4. 459A Program Amplifier (2 max.)	
One for single line/single or dual channel operation. Two for "stereo" or two channel/two line operation.	
5. 13387 Utility Input Device	
One for each high level input. Sum of 3 (a) above and 5 cannot exceed 10.	
6. 7160 V.U. Meter	
For second channel. Add for "stereo" or two line operation.	
7. 5981 Tube Test Meter	
8. Altec Monitor Amplifier	
Use as separate accessory.	

Preamplifiers, program amplifiers, power supplies & accessories

The 7160 V. U. Meter is an exact duplicate of the meter furnished in the 250 SU Altec Control Console, and mounting space is adjacent to the meter furnished. Meter illuminating lamps and mounting facilities and pads are part of the 250 SU Console so no special tools are required for installation or connection of the meter. A second meter is required for "stereo" or two-channel/two-line operation.

The 13387 unit is a Utility Input Device for high level input sources. This is an isolation transformer built on a "plug-in" chassis of the same size and dimensions as the 458A Altec "Plug-in" Preamplifier, and is designed for insertion into the standard 13401 Mounting Tray Assembly. Type 13387 is for "bridging" a 150 or 600 ohm line or matching a 15,000 ohm line. The unit is cadmium plated with a dichromate dip and weighs 1 pound.

The 5981 Tube Test Meter is an accessory to the 250 SU Altec Control Console unit. It is used to visually test the tube condition of the tubes used in the "plug-in" amplifiers type 458A and 459A. Mounting provisions and wiring for the meter are inside the console, located in the right rear section. No special tools are required for mounting. When installed, the meter provides, in addition, an indication of heater voltage by means of a push button switch and suitable shunt which is a standard part of the console.

RACK MOUNTING FACILITIES

The 13225 is available for use in rack mounting of speech input equipment. The rack mounting assembly is drilled to accept nine type 13401 Mounting Tray Assemblies for use with Altec 458A and 459A "Plug-in" Amplifiers and Altec 13387 Utility Input Device.

The 13225 assembly is for standard 19" rack or equipment cabinet mounting and occupies only 5¼" of panel space. The assembly has a "Snap-in" removable front cover for instantaneous access to the units for test or service. The finish of the front cover is Dark Green, and the complete assembly weighs 4 pounds.

For rack mounting 535A Power Supply, 10440 10½" Blank Panel may be used or Power Supply may be mounted on wall of equipment cabinet.

The 13401 is furnished as part of the 250 SU Altec Control Console, however, it is available separately to provide mounting and "plug-in" connection facilities for 458A and 459A Altec "Plug-In" Amplifiers or the 13387 Utility Input Device, when mounted in the 13225 Rack Mounting Assembly. The 13401 finish is cadmium plate with dichromate dip. The tray assembly is complete with "mating" female receptacle to accept the 458A, 459A and 13387 units. The tray measures 1¾" W x 7/8" H x 9" L (over terminals), and weighs ½ pound.

7160
V.U. METER



13387
UTILITY
INPUT
DEVICE

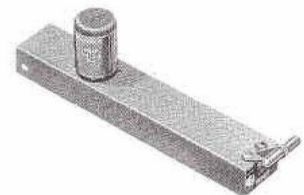

5981
TUBE TEST METER



13225
RACK MOUNTING ASSEMBLY



13401
MOUNTING
TRAY
ASSEMBLY

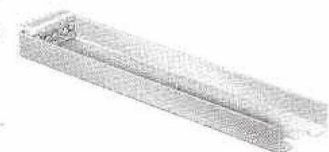

technical data 250 SU console

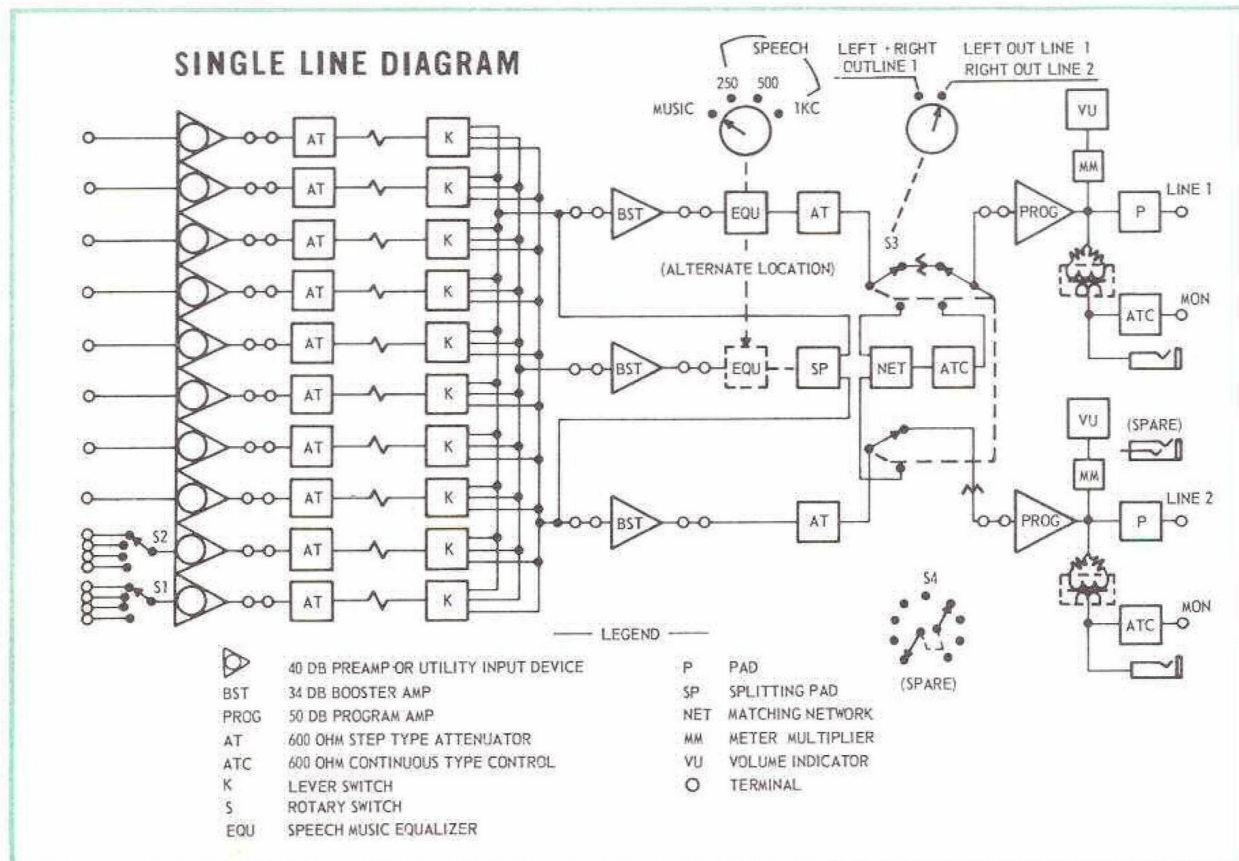

specifications

Microphone Input to Line Output

Gain: 98db (Includes 6 db line isolation pad)

Frequency Response: ± 1 db 30 to 15,000 cps.

Distortion: 0.5% 30 to 15,000 cps. at output level of +20dbm and less than 1% at +24 dbm.

Signal to Noise Ratio: 70 db (+18 dbm output with -50 dbm input)

High Level Channels

Gain: 41 db

Frequency Response: ± 1 db 30 to 15,000 cps.

Distortion: 0.5% 30 to 15,000 cps. at +20 dbm output and less than 1% at +24 dbm output.

Signal to Noise Ratio: 70 db (18 dbm output with -10 dbm input)

Source Impedances

Microphone Inputs: 150 or 600 ohms

Line or Utility Inputs: Up to 15,000 ohms

Load Impedances

Line Outputs: 600 ohms

Monitor Outputs: 600 ohms (Requires Separate Monitor Amplifiers)

Headphone Outputs: 600 ohms

Additional Specifications

VU Meters: One furnished complete with meter illuminating lamps, mounting facilities and pads. (A second meter is required for "stereo" or two-channel/two line operation. Available separately as an accessory.)

Cable

Terminations: Internally mounted WE Type L6A terminal board.

Patch Panel: All major circuits brought to jumpered terminals to provide means for wiring out jacks, if required.

Channels:

One, two or three divided to two for stereo use.

Attenuators:

Ten mixers. (All 600-ohm step type attenuators.) Two masters or two sub-masters and one board master. Two monitors.

Keys:

Ten three-position keys make each mixer attenuator selectable to three buses.

Rotary Switches:

Inputs 1 and 2 have switches providing choice of four program sources each, for utility use. (Total of 16 connected inputs.) Two-position line output switch. One additional spare provided but not wired.

Filters:

One four-position speech-music filter provided.

Headphone Jacks:

Three, two for channel monitoring. Third unwired to be used for intercom, etc.

Amplifiers:

Broadcast quality "plug-in" type. Input transformers 90 db magnetic shielding. Input and output 150 or 600 ohms balanced. Two amplifier types (Preamp & Program-amp), same physical size.

Power Supply:

Completely enclosed cube for external mounting (under table, wall, etc.) with interconnecting cable and connectors. Supplies B+ and 6.3v dc for heaters.

Panels:

Aluminum, standard Altec color with characters etched and filled. Panels may be engraved when additional markings are required.

Cabinet:

Hinged two-slope control panels painted Dark Green. Contains all equipment except power supply and monitor amplifier(s).

Dimensions:

9 1/2" H., 39 1/4" W., 16" D.

Mounting:

Table or desk, not supplied.

Accessories:

458A Plug-In Preamplifier and Booster Amplifier.
459A Plug-In Program Amplifier.
13387 Plug-In Utility Input Device for High Level Sources.
535A Power Supply.
7160 V.U. Meter for Second Channel.
5981 Tube Test Meter.

220A

ALTEC
LANSING CORPORATION

1957
portable mixer



The 220A Portable Mixer was developed by Altec to fulfill all requirements for a high quality broadcast mixer for field use in AM, FM, and TV remote pickup. Designed for high level mixing, this compact unit incorporates the use of two 1410A dual preamplifiers with individual volume controls for four microphone inputs, a 1440A line amplifier, a master volume control, a 30A power supply and a large 4" illuminated VU meter. Other components include a phone jack for use in headset monitoring, a power switch and output impedance selector switch.

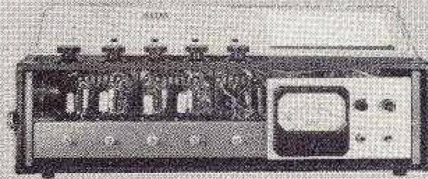

a

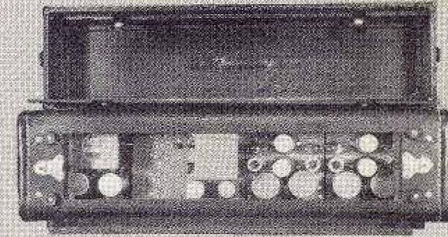

b

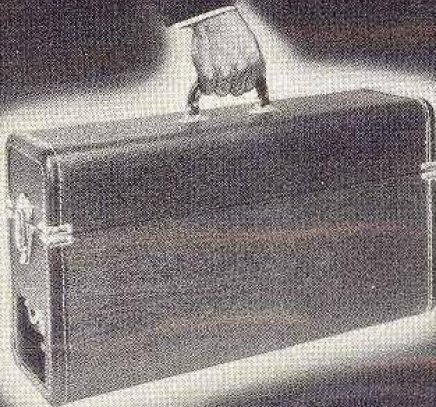

c

- a Control panel is removable for servicing.
- b Tubes are readily accessible and top cover has cable compartment.
- c The mixer in operating position.
- d Right end of chassis showing AC receptacle, battery receptacle and line terminals.
- e Left end of chassis with the four microphone input receptacles.

The 220A makes an ideal portable mixer for public address systems as it can be conveniently moved to various locations to meet almost any requirement. If additional facilities are required two mixers can be used together which will control 8 microphone inputs. The output of this mixer will work directly into the power amplifier of the sound system.

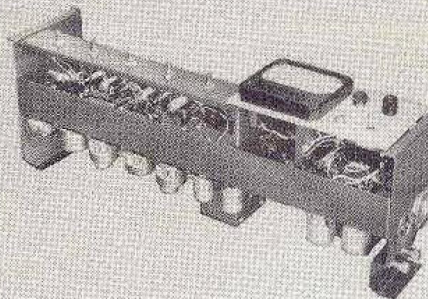

d

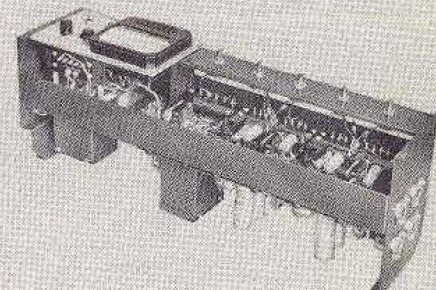

e

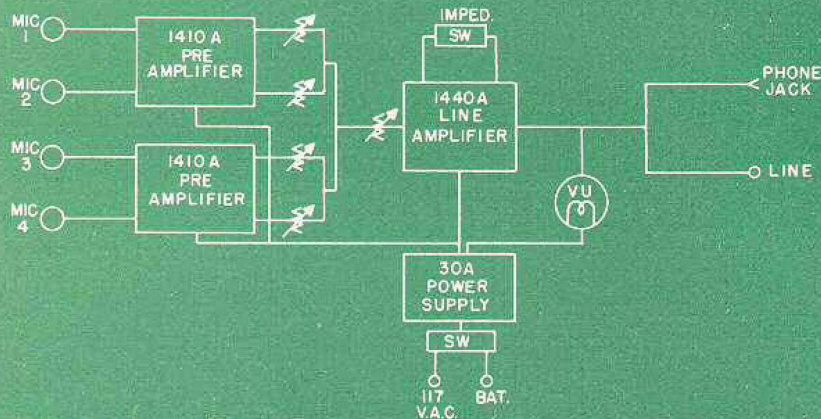

• 220A MIXER •

Outstanding Features...

Real Portable Equipment—compact and light in weight.

Equipment housed in one case.

Weight 26½ pounds.

Can be operated from impedances of 30, 125/250 or 500/600 ohms.

Has selection of output impedance of either 150 or 600 ohms through selector switch.

Frequency response uniform with, ± 1 db from 30 to 15,000 cycles.

Low harmonic distortion and low noise level.

Self-contained power supply.

Operates from either AC or external battery power supply.

Indirectly illuminated volume indicator gives output level in VU.

Flexible Control—four parallel mixers working from preamplifiers into a master gain control.

Non-glare brushed aluminum finish control panel.

Headset jack allows 2 way communication on line prior to program.

Normally supplied with carbon potentiometers. Mounting bracket designed for substitution of Daven potentiometers, if desired.

Accessibility—easy access to interior without disconnecting any cords or wires by removing front panel.

Tubes readily replaceable through bottom access door in carrying case.

Chassis readily serviceable as a unit by removing four screws and lifting from carrying case.

Microphone receptacle mounting allows for substitution of other microphone receptacles.

Facilities for carrying spare fuse and normal complement of spare tubes.

Space in carrying case for headset and cable.

Rugged construction assures long service and dependability.

Can be modified for V. R. phono pickup.

Technical Data...

GAIN:
80 db

FREQUENCY RESPONSE:
 ± 1 db 30 to 15,000 cycles

NOISE LEVEL:
AC OPERATION
-64 db at 70 db gain and peak output of +18 dbm

BATTERY OPERATION
-70 db at 70 db gain and peak output of +18 dbm

INPUT IMPEDANCE:
30, 125/250 or 500/600 ohms

OUTPUT IMPEDANCE:
150 or 600 ohms (controlled by selector switch)

OUTPUT LEVEL:
+18 dbm at less than 1% harmonic distortion

TUBES:
1410A PREAMPLIFIERS (2)
4-6AQ6; 4-6C4

1440A LINE AMPLIFIER
1-6AU6; 1-6C4

30A POWER SUPPLY
1-6X4

POWER REQUIREMENTS:
AC

117V, 50-60 Cycles AC, 60 watts

BATTERY
6V @ 3.2 amps — 270V @ 40 ma.

FUSE:
1 Amp 3 AG

WEIGHT:
26½ pounds

DIMENSIONS:
(COVER OFF)
23¼" long, 8¼" deep and 6½" high

(COVER ON)
23¼" long, 12¼" deep and 6½" high

FINISH:
Black imitation pebble grain leather with reinforced edges

ACCESSORY:
Battery cable plug

The New ALTEC 670 CARDIOID MICROPHONE

The 670 microphone is the answer to an increasing demand for a cardioid microphone that will deliver highest quality performance at moderate cost. It is similar in appearance and performance to the famous 639 model but much smaller in size and lighter in weight.

The 670 is a true cardioid microphone consisting of a ribbon-type element coupled to an acoustical network and enclosed in an attractive plastic housing which serves as a protective guard and wind screen. It is equipped with a swivel head with a $\frac{5}{8}$ " x 27 stand thread and a three prong microphone receptacle for attachment to plug and cable.

A unique design of this microphone is the shutter which is a double slot type allowing easy and immediate selection of the desired directivity pattern by means of the adjusting screw. Setting the shutter located at the rear of the microphone to positions P, C, or R will provide the three basic patterns as illustrated. Settings of the shutter between these points will provide variations of these three basic patterns. A feature of this arrangement is that it is possible by shutter adjustment to continually shift the null point of the microphone over a 90° angle and thereby effectively tune out sources of undesirable noise.

The 670 microphone because of its cardioid directional performance over the entire useful frequency range is an excellent all-purpose microphone. It has a wide angle pickup of at least 120° at the front over which the quality is not changed. Engineers in the sound field will find this microphone invaluable when confronted with troublesome studio, theatre, or auditorium jobs. Especially will radio and TV broadcast studios find the directional characteristics of the 670 microphone particularly efficient in excluding unwanted studio and audience noises while providing a wide angle of program pickup.

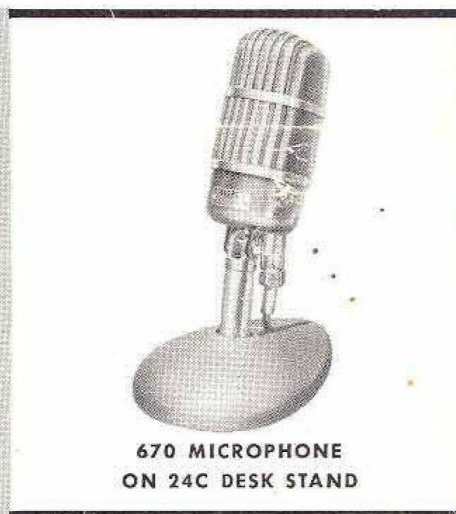
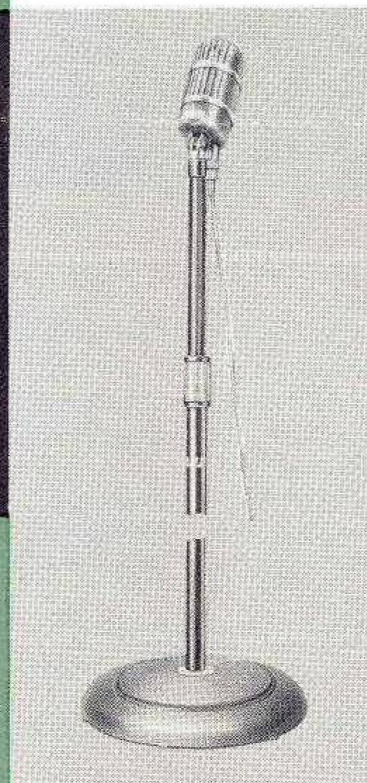
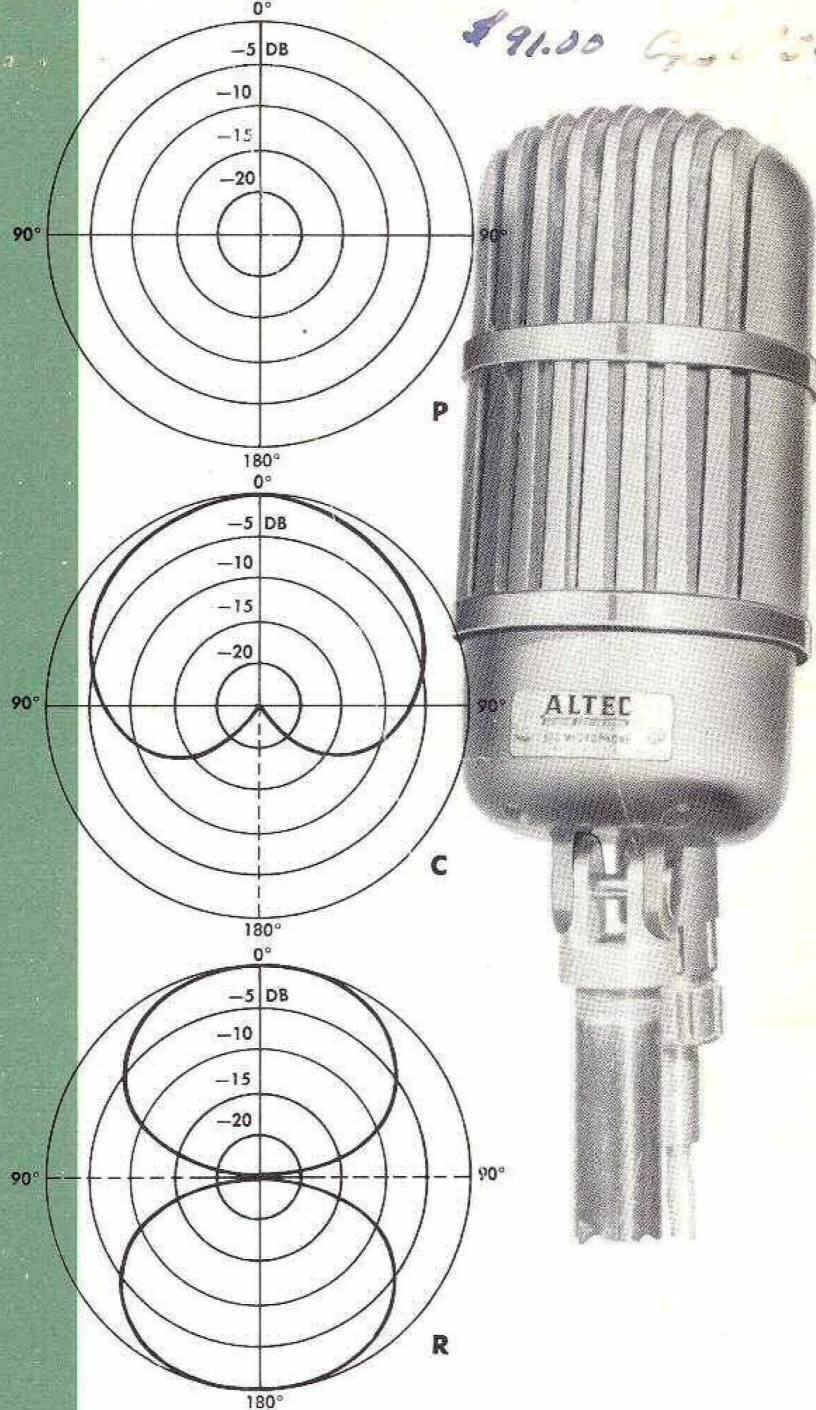

670 MICROPHONE
ON 24C DESK STAND



OUTSTANDING FEATURES

Excellent frequency response
High output level
Low noise level
Small
Rugged
Light weight
Low hum pickup
Hi/Low impedance (thru selector switch)

Variable directional patterns
True cardioid pickup pattern—
minimizes feedback, audience, and
background noise
Wide range pickup at front end and
sharply attenuated output at rear
with 18 db discrimination

TECHNICAL DATA

Response—Uniform 35 to 15,000 cycles in cardioid position.

Directivity—Three basic patterns P, C, or R obtainable when screwdriver operated switch attached to shutter is set at these respective positions so marked at opening on rear of microphone. Variations of these patterns available at settings of shutter between these points.

At the angle of minimum response the average discrimination with respect to the zero degree response of the microphone is 18 db.

Impedance—30/50 ohms or 150/250 ohms by means of selector switch. (Located under nameplate.)

Output Level—58 dbm for 10 dynes/sq. cm.

Dimensions—
Height—7½" (including swivel head)
Depth—3¾"
Width—2½"
Weight—1¼" lbs.

Mounting—Equipped with swivel head with ⅝" x 27 stand head for mounting either on an Altec 22C Floor-Stand, 24C Desk Stand or any Standard Stand.

Accessories—22C Floor Stand. Height adjustable—35"-64"
24C Desk Stand.

ARCHITECTS' AND ENGINEERS' SPECIFICATIONS

The microphone shall be the Altec 670 Cardioid Microphone or equivalent.

The microphone shall consist of an improved ribbon-type velocity element coupled to a labyrinth, assembled in a streamlined plastic housing. By means of a movable shutter microphone, it shall be possible to obtain various directivity patterns.

The pattern provided by combining the outputs of these elements shall be cardioid in form. The average discrimination between the front and back of the microphone shall be 18 db.

The microphone shall have a smooth response over

the range from 35 to 15,000 cycles. The available impedances shall be 30/50 ohms or 150/250 ohms obtainable by means of a screwdriver selector switch accessible through an opening under the name plate on front of the microphone.

The output level shall be—58 dbm for 10 dynes/sq. cm. The microphone shall have a height of 7½" (including swivel head), a depth of 3¾", a width of 2½" and a weight of 1¼ lbs.

The microphone shall be equipped with a swivel head with a ⅝" x 27 stand thread for mounting either on an Altec 22C Floor Stand or 24C Desk Stand.

ORDERING INFORMATION—Order: 670A Cardioid Microphone

M20 Condenser Microphone System

M20

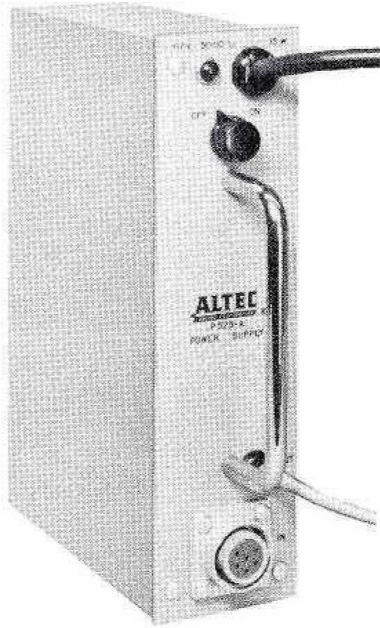

525A Power Supply

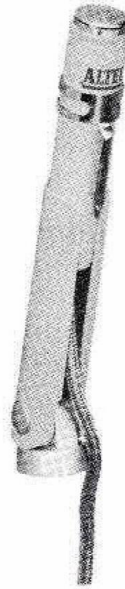

21D Microphone, 165A Base,
166A Attachment

Small size

Smoothest frequency response

Omnidirectional pickup

Laboratory quality

Shock & blast proof

Non-magnetic

Great stability

Beautifully styled

Lapel, stand, hand or
suspension mount
without accessories

No hum pickup

The Altec M20 "Lipstik" Microphone System represents a degree of quality, performance and flexibility which can not be found in any other commercial microphone. Heart of the system is the 21D condenser microphone which is the only application of the condenser principle that has successfully combined the quality that makes this type of microphone desirable as a laboratory standard and the durability necessary for the most grueling commercial use. In fact its smooth wide-range response makes it superior to any other type of commercial microphone and it is so rugged that it will withstand the severest shocks.

The complete M20 system consists of the 21D microphone, the 165A base, the 166A "slip-on" stand holder and swivel, 15 feet of slender, highly flexible Fiberglas covered mike cable and the 525A Power Supply. As supplied, the M20 system can be used as a stand-mounted or suspended microphone, can be quickly slipped from its stand holder for hand use or complete freedom of movement, may be clipped to the lapel or clothing with the sturdy clip attached to the base.

The 525A Power Supply provides the necessary voltages to polarize the condenser microphone, and the sub-miniature impedance matching tube and printed circuit in the 165A Base to which the microphone is attached.

Output from the Power Supply is for unbalanced lines. Balanced output can be achieved through the addition of the accessory 4665 Matching Transformer.

The extreme smoothness of response and great uniformity of the omnidirectional pickup make the M20 Microphone System ideal for all quality recording and broadcast requirements. Its smoothness often permits higher average sound levels in public address systems before feedback is encountered and its ruggedness and freedom from magnetic pickup make it ideal in the most difficult industrial and outdoor applications.



1515 S. Manchester Ave., Anaheim, Calif.

New York, Los Angeles

SPECIFICATIONS

Type:	Condenser
Frequency Response:	20 to 15,000 cycles
Output Level (Unbalanced):	@ 30 ohms, -59 dbm/10 dynes/cm ² @ 150 ohms, -53 dbm/10 dynes/cm ² @ 600 ohms, -49 dbm/10 dynes/cm ² @ Hi Z, -44 dbm/10 dynes/cm ² (10,000 ohms) or -30 db/1 v/10 dynes/cm ² (Balanced, using 4665 plug-in transformer: 30, 150, or 600 ohms, -48 dbm/10 dynes/cm ²)
Load Impedance:	30, 150, 600 and 10,000 ohms, unbalanced 30, 150, and 600 ohms, balanced using 4665 transformer
Pickup Pattern:	Omnidirectional
Hum:	Not susceptible to magnetic fields
Capacitance:	6 mmf.
21D Microphone Dimensions:	5/8" diameter, height 3/8"
21D Microphone Weight:	1/4 oz.
Unit Separation:	The microphone may be separated from the power supply up to 400 feet without any impairment in operation.
Cathode Follower Tube:	One 5840
166A Base Dimensions:	Length 2 13/16" (length in 166A attachment 5/4" including 21D) Diameter 1 1/16" Weight: 2 1/2 oz.
166A Stand Attachment:	Length 3 3/4" Diameter 3/4"
525A Power Supply Dimensions:	Length 8 3/8" Width 2 3/8" Depth 7 1/2" Weight: 5 1/2 lbs.
525A Power Requirements:	117 volts, 60 cycle, 15 watts
Microphone Mounting:	Suspension or hand held; and, with 166A attachment, 5/8" — 27 thread
Finish:	Microphone unit: stainless steel. Stand attachment: instrument gray with high impact styrene plastic. Power supply: instrument gray.

ACCESSORIES

See "Microphone Accessories" sheet for desk and floor stands, balanced line transformers, extension cable sets, bulk cable, rack mounting facilities, and other microphone accessories.

ARCHITECTS AND ENGINEERS SPECIFICATIONS

This microphone system shall be of the condenser type complete with power supply and connecting cable and plug. The microphone shall have a smooth frequency response over the range of 20 to 15,000 cycles and shall be free from "peaks" and "valleys" permitting high gain without "feedback." The system output level shall be: at 30 ohms, -59 dbm/10 dynes/cm²; at 150 ohms, -53 dbm/10 dynes/cm²; at 600 ohms, -49 dbm/10 dynes/cm²; at Hi Z, -30 db/1 v/10 dynes/cm²; balanced, using 4665 plug-in transformer, 30, 150, or 600 ohms, -48 dbm/10 dynes/cm². The system shall be designed to be non-susceptible to magnetic fields, the condenser element shall be omni-directional in pickup and the capacitance of the element shall be 6 mmf.

The condenser element shall measure no more than 5/8" diameter, 3/8" high, weigh 1/4 oz., and when fixed to the cathode follower base shall measure no more than 2 13/16" over-all. The system shall contain a standard attachment with 5/8" — 27 thread.

The standard attachment shall be of the slip-on type and when attached to the cathode follower base shall not exceed 5 1/4" over-all length with a diameter no greater than 3/4".

The complete system shall be composed of a condenser microphone element, cathode follower base shall not exceed 5 1/4" over-all length with a diameter no greater than shall contain a clamped diaphragm of gold and glass in a stainless steel casing.

Microphones utilizing plastic components with painted finish shall not be acceptable under these specifications.

(If used on balanced lines, provisions shall be available in the power supply for a plug-in transformer. This transformer shall have 90 db shielding encased in a metal housing and shall measure in the order of 2 5/8" h, 2" w, and 1 1/2" d.)

The microphone system shall be Altec Lansing Model M20.

M20 Condenser Microphone System

M20

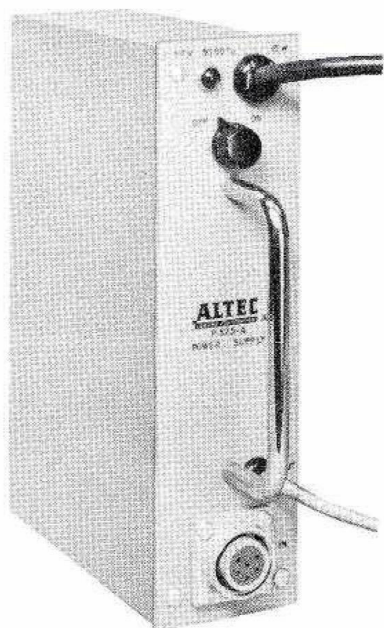

525A Power Supply

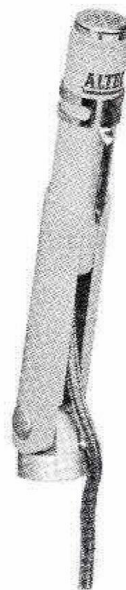

21D Microphone, 165A Base,
166A Attachment

Small size

Smoothest frequency response

Omnidirectional pickup

Laboratory quality

Shock & blast proof

Non-magnetic

Great stability

Beautifully styled

Lapel, stand, hand or
suspension mount
without accessories

No hum pickup

The Altec M20 "Lipstik" Microphone System represents a degree of quality, performance and flexibility which can not be found in any other commercial microphone. Heart of the system is the 21D condenser microphone which is the only application of the condenser principle that has successfully combined the quality that makes this type of microphone desirable as a laboratory standard and the durability necessary for the most grueling commercial use. In fact its smooth wide-range response makes it superior to any other type of commercial microphone and it is so rugged that it will withstand the severest shocks.

The complete M20 system consists of the 21D microphone, the 165A base, the 166A "slip-on" stand holder and swivel, 15 feet of slender, highly flexible Fiberglas covered mike cable and the 525A Power Supply. As supplied, the M20 system can be used as a stand-mounted or suspended microphone, can be quickly slipped from its stand holder for hand use or complete freedom of movement, may be clipped to the lapel or clothing with the sturdy clip attached to the base.

The 525A Power Supply provides the necessary voltages to polarize the condenser microphone, and the sub-miniature impedance matching tube and printed circuit in the 165A Base to which the microphone is attached.

Output from the Power Supply is for unbalanced lines. Balanced output can be achieved through the addition of the accessory 4665 Matching Transformer.

The extreme smoothness of response and great uniformity of the omnidirectional pickup make the M20 Microphone System ideal for all quality recording and broadcast requirements. Its smoothness often permits higher average sound levels in public address systems before feedback is encountered and its ruggedness and freedom from magnetic pickup make it ideal in the most difficult industrial and outdoor applications.



1515 S. Manchester Ave., Anaheim, Calif.

New York, Los Angeles

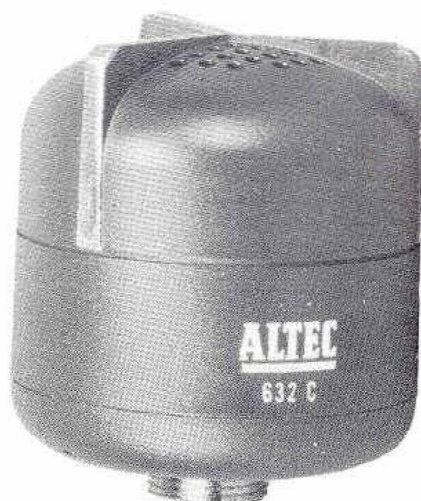

- Specialized speech instrument**
- Close-talking**
- High intelligibility**
- Temperature & humidity proof**
- Small size**
- High output**
- Low impedance**
- Rugged**
- Flexible**
- Inexpensive**

The 632C is specifically designed for clear, intelligible speech reproduction. This rugged close-talking microphone provides excellent results even where high ambient noise, background sound, or reverberation cause conventional microphones to be unsatisfactory. Its acoustically equalized frequency response generally eliminates the need for special speech equalization equipment in the associated amplifier system.

This true dynamic has a sensitive aluminum diaphragm employing tangential compliance, an edge-wound aluminum ribbon voice coil, and a highly efficient magnetic structure. This element is structurally protected from damage by loud speech or blowing and is unaffected by temperature changes, humidity, or breath condensation. A sturdy aluminum case minimizes danger of physical damage to the microphone.

Because of its low 30/50 ohm output impedance, the 632C may be operated several hundred feet from the amplifier without increasing noise pickup. As supplied, the 632C mounts directly on a stand in a vertical position. It may be "hand-held" or suspended from its cord. For angle mounting, the accessory 9A Swivel should be ordered. When the microphone is frequently taken from the stand, the 311A Plug may be attached for "plug-in" facility. The 422A Jack is used to terminate the microphone cord.

This specialized speech microphone offers the solution to many acoustical problems encountered in public address, paging, and roving announcement work, indoors or out. Its durability, performance, and truly reasonable price suit the 632C to most complex as well as to simplest sound installations.



1515 S. Manchester Ave., Anaheim, Calif.

New York, Los Angeles

SPECIFICATIONS

Type:	Dynamic
Frequency Response:	100 to 10,000 cycles
Output Impedance:	30/50 ohms
Output Level:	-55 dbm/10 dynes/cm ²
Dimensions:	Length 2 $\frac{1}{8}$ " Diameter 2"
Weight:	8 $\frac{1}{4}$ ozs.
Finish:	Instrument gray
Mounting:	$\frac{5}{8}$ " — 24 direct mounting

ACCESSORIES

See "Microphone Accessories" sheet for desk or floor stands, on-off switches, adapters, and other microphone accessories.

ARCHITECTS AND ENGINEERS SPECIFICATIONS

This microphone shall be of the dynamic moving coil type. It shall have an aluminum diaphragm with tangential compliance and the voice coil shall be of aluminum ribbon edge-wound. The frequency response shall be from 100 to 10,000 cycles. At 100 cycles it shall be approximately 6 db down and at 10,000 cycles shall be approximately 5 db down. From 150 to 10,000 cycles it shall have a gradually rising characteristic. This microphone shall have an impedance of 30/50 ohms and shall be balanced with respect to ground. The diameter of the microphone shall not exceed 2" with a length of not more than 2 $\frac{1}{8}$ ". The mounting adapter shall have $\frac{5}{8}$ " — 24 threads.

The microphone shall weigh not more than 8 $\frac{1}{4}$ ozs. The microphone shall be designed for close-talking operation. The unit shall be such as to be used with plug, jack, and adapter where specified. The output level of the microphone shall be at least -55 dbm/10 dynes/cm².

This microphone shall be Altec Lansing Model 632C.



- Proven design**
- Compact**
- High intelligibility**
- Not affected by temperature or humidity**
- Application flexibility**
- Wide frequency range**
- Omnidirectional or semi-directional**
- Exceptionally rugged**

The Altec 633 "Salt Shaker" Microphone is truly the accepted standard of the broadcast industry for a rugged, quality microphone both for routine studio use and field application. Its continued selection by experienced audio engineers is adequate proof of the durability of this exceptional design in broadcasting, recording and public address.

The Altec 633 type microphone is available in two models: the 633A with an output impedance of 30/50 ohms and the 633C which will provide either 30/50 or 150/250 ohm output.

Due to the perfect symmetry of the design, the 633 is completely omnidirectional in pickup and response to sounds arriving at an angle of 90° to the front of the diaphragm. When this feature is desired, the microphone is usually mounted vertically or suspended on its cordage. For sounds arriving perpendicular to the diaphragm, the response rises gradually from 1500 to 8000 cycles, providing a high degree of intelligibility for speech reproduction. This intelligibility characteristic can be further increased and a directional element introduced into the performance of the microphone by the addition of the accessory 8B Baffle which fits snugly around the face of the microphone.

Other accessories which add to the flexibility of the microphone include the 9A Swivel, and for those applications where it is undesirable to permanently wire the microphone to its cable, the 311A Plug may be permanently attached to the rear of the microphone. Complete data on these and other accessories will be found on the microphone accessories data sheet.

This famous microphone will be found ideal for those recording, broadcast, public address and sound distribution applications where high intelligibility, durability and long life are a requisite.



1515 S. Manchester Ave., Anaheim, Calif.

New York, Los Angeles

SPECIFICATIONS

Type:	Moving Coil Dynamic
Frequency Response:	35 to 12,000 cycles
Output Impedance:	633A — 30/50 ohms 633C — 30/50, 150/250 ohms, selective
Output level:	—55 dbm/10 dynes/cm ²
Dimensions:	Length 3½" Diameter 2"
Weight:	633A — 10 ozs. 633C — 13 ozs.
Finish:	Instrument gray
Mounting:	⅝" — 24 thread

ACCESSORIES

See "Microphone Accessories" sheet for desk or floor stands, on-off switches, adapters, and other microphone accessories.

ARCHITECTS AND ENGINEERS SPECIFICATIONS

This microphone shall be of the Dynamic Moving Coil type having the following specifications. The microphone shall have an aluminum diaphragm with tangential compliance and the voice coil shall be aluminum ribbon edge-wound. The frequency response shall be from 35 to 12,000 cycles. At 30 cycles it shall not be more than 6 db down and at 12,000 cycles not more than 8 db down. The microphone shall be available in (choose one) (a) 30/50, or (c) 30/50, 150/250 ohms, and shall be balanced with respect to ground. The diameter of the microphone shall not exceed 2" with a length of not more than 3½". The swivel adapter shall have ⅝" — 24 thread.

The microphone shall be so designed as to accept a separate baffle for semi-directional pickup pattern. The microphone only shall weigh not more than 13 ozs. The unit shall be designed to be used with plug, jack, and adapter where specified. The output level of the microphone shall be at least —55 dbm/10 dynes/cm².

The microphone shall be Altec Lansing Model 633 (select one) (A) or (C).

639 Cardioid Microphone

639



- Proven broadcast quality
- 6 directional patterns
- Sturdy construction
- 2 microphones in one
- Latest type velocity ribbon
- Low noise level
- Eliminates feedback
- Wide frequency range
- Adaptable mounting

The Altec 639 Microphone is accepted everywhere as the finest directional microphone made. It will be found in every major recording and broadcast studio. It is available in two models: 639A which has three directional patterns and 639B which provides selection of six distinct patterns. In either, microphone selection is made by a clearly marked screwdriver switch on the rear of the case.

The 639 is actually two microphones, being a combination of a moving-coil dynamic pressure element and an improved ribbon-type velocity element. These two components are enclosed in a sturdy attractive housing which also serves as a protective guard and wind screen.

Its low output impedance, 30/50 ohms, makes it possible to use this microphone at great distances from its associated amplifying equipment without fear of noise pickup or other quality deterioration.

The three basic pickup patterns available on both models are omnidirectional, bi-directional, and cardioid or uni-directional. The B model has three additional patterns which provide full frontal pickup and varying degrees of rear pickup while suppressing sounds from the sides.

A series of attachments, plugs and accessories are available to mount the 639 microphone in the best manner for any given application.

Broadcasters, recording engineers and public address users will find that the 639 is an invaluable microphone. Its outstanding frequency response, flexible directional patterns and discrimination provide the tools that make it possible to achieve top quality even under the most trying conditions of unwanted noises.



1515 S. Manchester Ave., Anaheim, Calif.

New York, Los Angeles

SPECIFICATIONS

Type:	Cardioid
Frequency Response:	40 to 10,000 cycles
Output Impedance:	30/50 ohms
Output Level:	-56 dbm/10 dynes/cm ²
Pickup Pattern:	639A - 3-directional pattern 639B - 6-directional pattern
Hum:	-120 db (Ref.: 10 ⁻³ Gauss)
Protection:	Two stage wind screen
Dimensions:	Height - 7½" (including plug) Width - 3⅞" Depth - 4⅞"
Weight:	3¼ lbs.
Finish:	Instrument grey

ACCESSORIES

See "Microphone Accessories" sheet for suspension, floor or desk stand mountings, adapters, and other microphone accessories.

ARCHITECTS AND ENGINEERS SPECIFICATIONS

The microphone shall be of the directional type employing both a dynamic moving coil pressure element and a ribbon-type velocity element, assembled in a streamlined housing, arranged so that their outputs can either be used individually or combined equally. The directivity patterns so provided shall be selectable through a screwdriver operated switch mounted flush on the microphone housing.

The patterns provided by combining the outputs of these elements shall be cardioid in form. The average discrimination between the front and back of the microphone shall be not less than 20 db over the range of 40 to 10,000 cycles per second. In the range from 70 to 7,000 cycles, the minimum discrimination at any frequency shall be 15 db. The construction of the microphone shall incorporate a two stage wind screen for protection of the velocity element.

The microphone shall have (select one) (A) 3 positions, (B) 6 positions. It shall have a smooth response and not deviate from the average more than ± 4 db over the range from 40 to 10,000 cycles. The average impedance throughout this range shall be on the order of 40 ohms.

The output level shall be -56 dbm/10 dynes/cm². The hum shall be no greater than -120 db (Ref.: 10⁻³ Gauss).

The microphone shall measure no greater than 7½" high (including plug), 3⅞" wide, and 4⅞" deep. It shall weigh on the order of 3¼ lbs. in order that a magnetic structure of proper size is usable in the construction of the unit. The microphone shall be finished in instrument grey, and shall be so constructed as to be adaptable to mounting either by suspension or on stands.

The microphone shall be Altec Lansing Model 639 (select one) (A) 3 pattern, or (B) 6 pattern.

661 Microphone

661A
661B

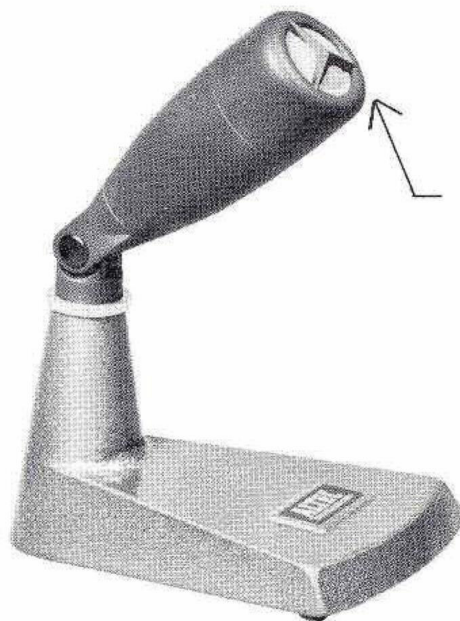

The AFD principle:

This new sintered bronze filter, exclusive with ALTEC, gives exceptionally wide range performance, eliminates high frequency peaks by providing an acoustical resistance loading to the front of the diaphragm, and seals the pressure element against dust, dirt, and moisture.

- Exclusive sintered bronze filter
- Acoustically loaded diaphragm
- New, high efficiency pressure element
- High output
- Dirt and moisture proofed
- Economical broadcast quality
- Guaranteed 30-15,000 cps frequency response
- High sensitivity
- Compact, attractively styled

The 661 is an economical dynamic microphone free of high frequency peaks common to conventional dynamic microphones. Low price and high quality are achieved through an exclusive Altec development—a sintered bronze filter sound entrance providing acoustic resistance loading to the front of the diaphragm. Acoustic front damping has an extended effectiveness to the high frequency region. It eliminates high frequency peaks that are left undamped by conventional damping methods. The filter also effectively seals the microphone from all foreign particles, even the finest iron dust.

Quality performance and reasonable price well suit the 661 to most broadcast and public address applications. It is recommended for paging when broadcast quality is required and is also excellent for high fidelity home recording.

A newly designed L2 pressure element incorporates an aluminum diaphragm with tangential compliance and a voice coil of edge-wound aluminum ribbon. It provides the 661 with high output and an exceptionally wide frequency response which is guaranteed from 30 to 15,000 cps.

This microphone is available in two models: the 661A with a 30/50 ohm impedance, the 661B with 30/50, 150/250 or 20,000 ohms selected by a readily accessible impedance control. The microphone is compact, attractive, and finished in non-reflecting dark green. A cast aluminum case protects the 661 from accidental damage.

Supplied complete with 15' two conductor shielded cable and swivel for mounting on Altec 25B Desk Stand.



1515 S. Manchester Ave., Anaheim, Calif.

New York, Los Angeles

SPECIFICATIONS

Type:	Dynamic
Pickup Pattern:	Omnidirectional
Frequency Response:	30-15,000 cps
Output Level:	-55 dbm/10 dynes/cm ²
Output Impedance:	661A - 30/50 ohms 661B - 30/50, 150/250, 20,000 ohms
Dimensions:	Diameter - 1 $\frac{5}{8}$ " Length - 5 $\frac{3}{16}$ " including swivel
Weight:	661A - 7 ozs. 661B - 9 ozs.
Finish:	Non-reflecting dark green
Mounting:	$\frac{5}{8}$ " - 27 swivel head Supplied with 15' two conductor shielded cable

ACCESSORIES

25B Desk Stand in matching green

ARCHITECTS AND ENGINEERS SPECIFICATIONS

The microphone shall be of the dynamic type Altec Lansing (choose one) (a) 661A, (b) 661B.

The sound entrance shall be sealed by a sintered bronze filter which shall provide acoustic resistance loading to the front of the diaphragm. This filter by loading the diaphragm shall serve to eliminate high frequency peaks. It shall also effectively seal out dirt and moisture to protect the pressure element. The frequency response shall be uniform from 30 to 15,000 cps. The case shall be approximately conical in shape and shall incorporate a built-in swivel. It shall be compact with overall dimensions not to exceed 1 $\frac{5}{8}$ " X 5 $\frac{3}{16}$ ". To provide for high output level and smooth response, the diaphragm shall be of aluminum with tangential compliance and the voice coil shall be of edge wound aluminum ribbon. The output level shall be at least -55 dbm. (S.P.L. = 10 dynes/cm²) and the output impedance shall be (choose one) (a) 30/50 ohms, (b) 30/50, 150/250, or 20,000 ohms balanced with respect to ground.

670B Cardioid Microphone

670B



Three standard and infinite
intermediate pickup patterns

High output

Low hum level

Wide frequency range

Moderate price

Impedance switch to
select outputs

Compact

Sturdy

Broadcast quality

The 670B Microphone is the answer to the increasing demand for a broadcast quality directional microphone at a moderate price. Small size and light weight suit this cardioid to many applications where the average bulky cardioid is impractical.

The 670B has unique directional characteristics. In addition to the standard omni-directional, bi-directional, and cardioid patterns which are selected by a screwdriver switch, a precision double-slotted shutter permits selection of any intermediate condition. This feature provides literally thousands of pickup patterns making it possible to shift null points of the microphone over a 90° angle to effectively "tune out" undesirable noises.

This sturdy microphone has an extremely sensitive aluminum alloy ribbon element coupled to a unique 36" labyrinthine acoustical network. This pressure element is enclosed in an attractive, high impact plastic housing which also serves as an effective wind screen. The microphone is equipped with a 5/8"-27 standard swivel head and a locking three prong receptacle. Either 30/50 or 150/250 ohm output impedance may be selected by a concealed switch.

The 670B with its smooth directional pattern over the entire useful frequency range is an excellent all-purpose microphone. Quality-wise it belongs in the finest recording studio or broadcasting station where a directional microphone solves many acoustic and audience noise problems. In public address, its directivity reduces feedback while increasing the system's useable reinforcement level.



1515 S. Manchester Ave., Anaheim, Calif.

New York, Los Angeles

SPECIFICATIONS

Type:	Cardioid
Frequency Response:	30 to 16,000 cycles
Output Impedance:	30/50 and 150/250 ohms (selectable by switch under nameplate)
Output Level:	-56 dbm/10 dynes/cm ²
Discrimination:	Average front to back, 15 db
Pickup Pattern:	Cardioid, omni-directional, bi-directional in established settings (with adjustable intermediate patterns)
Hum:	-130 db (Ref.: 10 ⁻³ Gauss)
Protection:	Two stage wind screen
Dimensions:	Height - 6½" (including swivel) Width - 2½" Depth - 3¾"
Weight:	1¼ lbs.
Finish:	Instrument gray
Mounting:	⅝" - 27 thread

ACCESSORIES

See "Microphone Accessories" sheet for desk and floor stands, on-off switches, couplings, and other microphone accessories

ARCHITECTS AND ENGINEERS SPECIFICATIONS

The microphone shall be of the directional type, employing a single ribbon velocity element coupled to a specially constructed "acoustic path" permitting three established directivity patterns; i.e., cardioid, omni-directional, or bi-directional, plus adjustable intermediate patterns ranging from omni-directional to cardioid.

This microphone shall have an output level of -56 dbm/10 dynes/cm². The average discrimination between the front and back of the microphone shall be not less than 15 db over the range of 30 to 10,000 cycles. The construction of the microphone shall incorporate a two-stage wind screen for the protection of the velocity element. The hum shall be no greater than -130 db (Ref.: 10⁻³ Gauss).

This microphone shall have a smooth response and shall not deviate from the average more than ±4 db over the range from 30 to 10,000 cycles, and shall not be more than 8 db down at 16,000 cycles. The impedance shall be selectable by a screwdriver switch either 30/50 ohms or 150/250 ohms.

The microphone shall not measure greater than 6½" high (including swivel), 2½" wide, and 3¾" deep. It shall weigh no more than 20 ozs. The entire housing shall be of "high impact styrene" for durability and long usage, and shall be of instrument gray plastic. A painted finish shall not be deemed acceptable under these specifications.

The swivel mounting of the microphone shall accommodate desk or floor stand threads of ⅝" - 27.

The microphone shall be Altec Lansing Model 670B.

671B Velocity Microphone

671B



- Bi-directional
- Wide frequency response
- High output
- Compact
- Sturdy
- Low noise level
- Minimum hum pickup
- High-low impedance selection
- Two-stage wind filter
- Inexpensive

The Altec 671B Microphone can be considered the finest velocity microphone in existence. It provides a bi-directional pickup of full broadcast quality, has an excellent signal-to-noise ratio and extremely low hum pickup. The high impact styrene case will withstand heavy abuse and provides full protection for the microphone elements. The two-stage wind screen effectively protects the ribbon element from wind noise, blowing and other abrupt air movements.

The compact, inexpensive microphone has a useful response from 30 to 16,000 cycles which is ideal for all public address, broadcast and recording applications.

A concealed switch under the name plate of the microphone provides selection of two output impedances: 30/50 or 150/250 ohms. For maximum utility the microphone is equipped with a swivel head and a $\frac{5}{8}$ " — 27 thread microphone stand connector. Electrical connection to the microphone is made through a Cannon plug mounted integrally in the bottom of the case. The mating XL-3-11 plug is supplied with the microphone at no extra cost.

For any application where the bi-directional advantages of a velocity microphone are desired, the Altec 671B will be found superior in every aspect.



1515 S. Manchester Ave., Anaheim, Calif.

New York, Los Angeles

SPECIFICATIONS

Type:	Velocity
Frequency Response:	30 to 16,000 cycles
Output Impedance:	30 / 50 and 125 / 250 ohms (selective by switch under name plate)
Output Level:	-54 dbm / 10 dynes/cm ²
Pickup Pattern:	"Figure 8" bi-directional
Hum:	-130 dbm (Ref.: 10 ⁻³ Gauss)
Protection:	Two-stage wind screen
Dimensions:	Height - 4½" (including swivel) Width - 2½" Depth - 3¾"
Weight:	14 ozs.
Finish:	Instrument gray finish
Mounting:	⅝" - 27 thread

ACCESSORIES

See "Microphone Accessories" sheet for desk and floor stands, on-off switches, couplings, and other microphone accessories.

ARCHITECTS AND ENGINEERS SPECIFICATIONS

The microphone shall be of the bi-directional "Figure 8" velocity type employing a single ribbon velocity element presenting a smooth frequency response over the range of 30 to 16,000 cycles.

The microphone shall have an output level of -54 dbm/10 dynes/cm², and the hum shall be no greater than -130 db (Ref.: 10⁻³ Gauss). The impedance shall be adjustable by screwdriver switch, 30/50 ohms or 125/250 ohms. The microphone construction shall incorporate a two-stage wind screen for the protection of the velocity element.

The microphone shall not measure greater than 4½" high (including swivel), 2½" wide, and 3¾" deep. It shall weigh no more than 14 ozs. The entire housing shall be of "high impact styrene" for durability and long usage, and housing shall be of instrument gray plastic. A painted finish shall not be deemed acceptable under these specifications.

The swivel mounting of the microphone shall accommodate desk or floor stand threads of ⅝" - 27.

The microphone shall be Altec Lansing Model 671B.

680A Acoustic Gate Microphone

680A

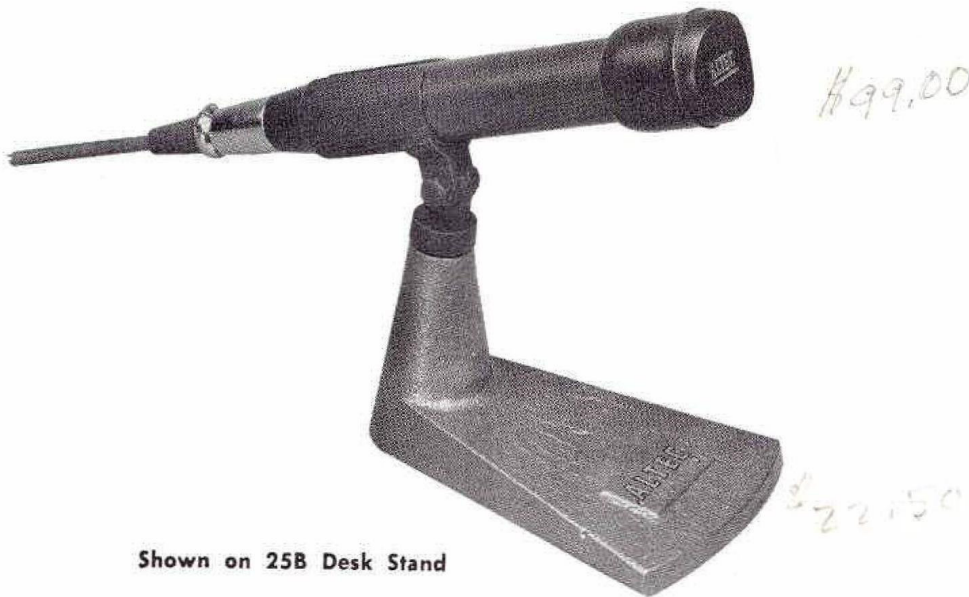

Shown on 25B Desk Stand

Smooth frequency response

Finest dynamic made

Modern styling

Dust & dirt proof

Protected from ferrous filings

Three output impedances

Slip-on stand holder

Light weight

Omnidirectional

Extra sturdy

The Altec 680A is the first microphone to use the new "Acoustic Gate" principle. This "Acoustic Gate" is a peripheral sound entrance channel which provides an acoustical resistance loading to the front of the diaphragm, thereby eliminating the high frequency peak normally found in dynamic microphones and extending the frequency response over an exceptionally wide range.

This outstanding Altec development in the acoustic art results in a rugged dynamic moving-coil microphone with a frequency range of 30 to 15,000 cycles per second, a range which readily places it within the most stringent of broadcasting and recording requirements. In addition the narrow sound entrance channel makes the 680A effectively impervious to dust, dirt, water and iron filings which destroy conventional dynamic types.

The appearance of the microphone makes it especially desirable in television, night club and public address work because of its slim profile and non-reflective finish.

The microphone is supplied with a slip-on stand mount of $\frac{5}{8}$ "—27 thread so that it can be rapidly changed from a hand held unit to conventional stand use without interruption of operation. The rear of the microphone contains a Cannon connector and is supplied with the mating plug pre-wired to twenty feet of microphone cable. A choice of three output impedances (30/50, 150/250 & 20,000 ohms) is provided through strapping terminals in the rear of the microphone.

The combination of high quality and the ruggedness of an outdoor microphone make the 680A the top choice for wide range performance in a modern microphone that will withstand the roughest imaginable treatment. Its design is positive insurance of reliability under all circumstances.



1515 S. Manchester Ave., Anaheim, Calif.

New York, Los Angeles

SPECIFICATIONS

Type:	Moving coil dynamic
Frequency Response:	30 to 15,000 cycles
Output Impedance:	Selective 30/50 ohms, 125/250 ohms, 20,000 ohms (Hi Z)
Output Level:	-58 dbm/10 dynes/cm ²
Dimensions:	Body diameter 1", head cover diameter 1½", length 7"
Weight:	8 ozs.
Finish:	Black head cover with green (anodized) body, and black mounting adapter
Mounting:	Separate "Slip-On" Adapter (furnished) to permit instantaneous removal of microphone from stand for hand use. Adapter has standard ⅝" — 27 thread, swivel mounting permits use of microphone in any position. A neck cord #12478 for use as a "lavalier" is available on request.

ACCESSORIES

See "Microphone Accessories" sheet for desk or floor stands, on-off switches, adapters, and other microphone accessories.

ARCHITECTS AND ENGINEERS SPECIFICATIONS

The microphone shall be of the "Acoustic Gate" Dynamic Moving Coil type, having the following specifications. The microphone shall have a voice coil of flat aluminum ribbon-edge wound. The microphone shall have a narrow peripheral sound entrance channel. The frequency response shall be from 30 to 15,000 cycles. At 30 cycles it shall not be more than 6 db down and at 15,000 cycles not more than 5 db down.

Throughout the range of 100 to 10,000 cycles it shall be flat within a range of 3 db. The microphone shall have impedance selections of 30/50, 125/250, and 20,000 ohms and shall be balanced with respect to ground. The output level shall be -58 dbm/10 dynes/cm². The maximum diameter shall not exceed 1½" with a body diameter of 1" and a length of 7". The microphone "slip-in" holder shall have standard ⅝" — 27 threads. The holder shall be one of special design for the specified microphone. The microphone only shall not weigh more than 8 ozs.

The microphone shall be Altec Lansing Model 580A.

681A Omnidirectional Microphone

681A



Features:

Response From 50 to
18,000 Cycles

Omnidirectional Pickup
Pattern

Special Altec
Mylar® Diaphragm

Blast and Shock Resistant

Withstands Extreme
Temperature Variations

High Output Level

Smart Styling —
Rugged Construction

Moderately Priced

PAGING • SOUND SYSTEM • HOME RECORDING RADIO AMATEUR • GENERAL PURPOSE

The model 681A microphone is a high quality, inexpensive unit, having an omnidirectional pickup pattern and is designed for general purpose installations such as public address systems, public speaking and paging systems.

This microphone incorporates Altec's dynamic moving coil and the new *Golden Diaphragm* of Mylar® polyester to provide smooth, uniform frequency response from 50 to 18,000 cycles. The new diaphragm is also highly resistant to shock, blasts, corrosive fumes, and temperature extremes assuring the user of extensive microphone service life.

The microphone has been styled for a slim, tapered appearance, is light in weight and comfortably balanced for hand-held use. It is available finished in either dark green enamel or brushed chrome and comes complete with cable and slip-on adapter for stand use.

To match requirements of the installation, the model 681A is supplied with either 150/250 or 20,000 ohms output impedance.



A Subsidiary of Ling-Temco Electronics, Inc.

1515 S. Manchester Ave., Anaheim, Calif.

New York, Los Angeles

PERFORMANCE SPECIFICATIONS:

Type:	Moving Coil Dynamic
Frequency Response:	50 to 18,000 cycles
Output Impedance:	150/250 or 20,000 ohms (specify impedance)
Output Level:	-55 dbm/10 dynes/cm ²
Pickup Pattern:	Omnidirectional
Hum:	-120 db (Ref.: 10 ⁻³ Gauss)
Dimensions:	1½" diameter at top, 7¾" long
Weight:	10 ozs. (including cable)
Finish:	Dark Green baked enamel, or brushed chrome (specify)
Mounting:	Separate "Slip-On" adapter No. 13338 furnished Adapter has standard ⅝" — 27 thread
Accessories:	See "Microphone Accessories" sheet for desk or floor stands, on-off switches, adapters, and other microphone accessories.

ARCHITECTS AND ENGINEERS SPECIFICATIONS

The microphone shall be of the dynamic moving coil type employing a diaphragm of Mylar® polyester to provide full protection against extreme shock and blasts. The diaphragm shall withstand exposure to temperature variations or from -20 degrees F to 160 degrees F and shall not be susceptible to the effects of corrosive fumes. The frequency response shall be uniform from 50 to 18,000 cps. The case shall be conical in shape and shall not measure more than 1½" in diameter in its largest dimension and shall be no longer than 7¾". The microphone shall be furnished complete with a slip-on adapter for mounting on a microphone stand. The output level shall be at least -55 dbm (SPL equals 10 dynes/cm²) and the output impedance shall be selectable at 150/250 and 20,000 ohms (specify impedance) balanced with respect to ground. The hum shall be no greater than -120 db (Ref.: 10⁻³ Gauss).

This microphone shall be Altec Lansing Model 681A.

682A Omnidirectional Microphone

682A

Sintered  Bronze Filter



Features:

Wide Frequency Response

Omnidirectional Pickup
Pattern

Rugged Mylar® Diaphragm

Blast and Shock Resistant

Exclusive Sintered
Bronze Filter

Dirt and Moisture Proof

Withstands Humidity and
Temperature Extremes

Impedance Selection
Built-In

Sturdy Reliable
Construction

Attractively Styled

SOUND SYSTEMS • PAGING • BROADCASTING
TELECASTING • RECORDING

Designed for general purpose use, the 682A microphone incorporates the many proven design factors developed by Altec's pioneer work in the field of dynamic transducers. Wide range and uniform frequency response are attained by the use of Altec's new outstanding *Golden Diaphragm* which provides great resistance to shock and blast, is not affected by commonly encountered corrosive fumes, and assures continued sound pickup under the most adverse conditions. Protection of the diaphragm and acoustic element from extreme humidity, moisture, and foreign particles is provided by Altec's exclusive sintered bronze filter.

Omnidirectional pickup characteristics make the 682A an ideal unit for sound systems, paging, music, broadcasting and recording. The microphone utilizes the moving coil dynamic principle, accepted as standard for efficient pickup, and has a uniform frequency response from 45 to 20,000 cycles. Impedances of 30/50, 150/250 and 20,000 ohms can be selected in the microphone cable plug permitting use of the 682A under varying operating requirements.

The microphone housing is custom-styled resulting in a slim, conical profile, with minimum weight. It is available in a choice of finishes. A slip-on adapter with standard $\frac{5}{8}$ " - 27 thread is supplied to enable quick removal and replacement of the microphone on the stand.



A Subsidiary of Ling-Temco Electronics, Inc.

1515 S. Manchester Ave., Anaheim, Calif.

New York, Los Angeles

PERFORMANCE SPECIFICATIONS:

Type:	Moving Coil Dynamic
Frequency Response:	45 to 20,000 cycles
Output Impedance:	30/50, 150/250 and 20,000 ohms (selection by connections in microphone cable plug)
Output Level:	-55 dbm/10 dynes/cm ²
Pickup Pattern:	Omnidirectional
Hum:	-120 db (Ref.: 10 ⁻³ Gauss)
Dimensions:	1 1/8" diameter at top, 7" long, not including plug
Weight:	8 ozs. (not including cable and plug)
Finish:	Two-tone baked enamel, black and dark green, or dark brown and platinum, or brushed chrome
Mounting:	Separate "Slip-On" adapter No. 13338 Furnished Adapter has standard 5/8" — 27 thread
Accessories:	See "Microphone Accessories" sheet for desk or floor stands, on-off switches, adapters, and other microphone accessories.

ARCHITECTS AND ENGINEERS SPECIFICATIONS

The microphone shall be of the dynamic moving coil type having the following specifications. The microphone shall have a diaphragm of Mylar® with tangential compliance and shall be fully protected against extreme shock and blasts. The diaphragm shall withstand exposure to temperature variations from -20 degrees F to 160 degrees F and shall not be susceptible to the effects of corrosive fumes. The microphone sound entrance shall be protected by a sintered bronze filter to prevent water, moisture, dust or ferrous particles from contaminating the acoustical element. The frequency response shall be uniform from 45 to 20,000 cps. The case shall be conical in shape and shall not measure more than 1 1/8" in diameter at the top, and shall be no longer than 7" not including the cable connector. The output level shall be at least -55 dbm (SPL equals 10 dynes/cm²) and the output impedance shall be selectable at 30/50 and 150/250 and 20,000 ohms balanced with respect to ground. Provisions shall be available in the microphone cable plug for selecting the required impedance.

This microphone shall be Altec Lansing Model 682A.

683A *Cardioid* Microphone

683A

Sintered



Bronze Filter



Features:

- Cardioid Pickup Pattern**
- Special Mylar® Diaphragm**
- Impedance Selection Built-In**
- Exclusive Altec Filter**
- Resistant to Shock and Blasts**
- Unaffected by Humidity Extremes**
- Withstands Temperature Variations**
- Highest Recording Quality**
- Sturdy Compact Styling**

TELECASTING • BROADCASTING • RECORDING PAGING • PUBLIC ADDRESS SYSTEMS

The Altec model 683A microphone is a Cardioid type incorporating all the engineering benefits of a dynamic moving coil unit, combined with a newly designed compliance configuration. Response of this Model 683A is far beyond most conventional cardioid types, being flat from 45 to 15,000 cycles.

Altec's new *Golden Diaphragm* of Mylar® polyester used in the 683A, provides smooth, uniform response and extreme ruggedness and durability. The diaphragm is highly resistant to the effects of shock, blast, or corrosive fumes. A new sintered bronze filter used in the model 683A assures even further protection of the acoustical element by prohibiting the entrance of any foreign particles or moisture.

As with other Altec microphones in this series, the model 683A is styled for an attractive slim-line appearance. It is available in a choice of finishes, and comes complete with cable and a slip-on adapter for use with a microphone stand. Impedance selection is conveniently built into the cable connector plug.

The 683A cardioid-type microphone is most useful in installations where sound pickup should be from one direction only, or where background or feed-back may be a problem. It is recommended for any application where a high quality unit of this type is called for.



A Subsidiary of Ling-Temco Electronics, Inc.

1515 S. Manchester Ave., Anaheim, Calif.

New York, Los Angeles

PERFORMANCE SPECIFICATIONS:

Type:	Cardioid Dynamic
Frequency Response:	45 to 15,000 cycles
Output Impedance:	30/50, 150/250 and 20,000 ohms (selectable by connections in microphone cable plug)
Output Level:	-54 dbm/10 dynes/cm ²
Discrimination:	Average front to back, 20 db
Pickup Pattern:	Cardioid
Hum:	-120 db (Ref.: 10 ⁻³ Gauss)
Dimensions:	1½" diameter at top, 7¼" long, not including plug
Weight:	11 ozs. (not including cable and plug)
Finish:	Two-tone baked enamel, black and dark green, or dark brown and platinum or brushed chrome plating
Mounting:	Separate "Slip-On" adapter No. 13339 furnished to permit instantaneous removal of microphone from stand. Adapter has standard ⅝" — 27 thread. Swivel mounting permits proper positioning of microphone on all stands. Microphone complete with 15 foot, 2 conductor shielded cable.
Accessories:	See "Microphone Accessories" sheet for desk or floor stands, on-off switches, adapters, and other microphone accessories.

ARCHITECTS AND ENGINEERS SPECIFICATIONS

The microphone shall be of the Cardioid type employing the moving coil dynamic principal with a diaphragm of Mylar® having tangential compliance to provide full protection against extreme shock and blasts. The diaphragm shall withstand exposure to temperature variations of from -20 degrees F to 160 degrees F and shall not be susceptible to the effects of chemical fumes. The microphone sound entrance shall be protected by a two-stage filter composed of one sintered bronze and one cast screen to prevent water, moisture, dust or ferrous particles from contaminating the acoustical element. The frequency response shall be uniform from 45 to 15,000 cps. The case shall be conical in shape and shall not measure more than 1½" in diameter in its largest dimension and shall be no longer than 7¼" not including connector. The microphone shall be furnished complete with a slip-on adapter for mounting on a microphone stand. The output level shall be at least -54 dbm (SPL equals 10 dynes/cm²) and the output impedance shall be selectable at 30/50, 150/250 and 20,000 ohms balanced with respect to ground. The average discrimination between the front and back of the microphone shall be in the order of 20 db over the range of 45 to 15,000 cycles. The hum shall be no greater than -120 db (Ref.: 10⁻³ Gauss). Provisions shall be available in the microphone cable plug for selecting the required impedance.

This microphone shall be Altec Lansing Model 683A,

684A Omnidirectional Microphone

684A

Sintered Bronze Filter

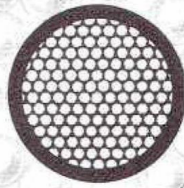

Features:

- Extended Frequency Response
- Omnidirectional Pickup Pattern
- Specially Designed Mylar® Diaphragm
- Famous Altec Sintered Bronze Filter
- Full Protection Against Ferrous Particles
- Impervious to Shock and Blasts
- Dust and Moisture Proof
- Light Weight — Small Size
- Comfortably Balanced for Hand Use
- Unaffected by Humidity Extremes
- Built-in Impedance Selection
- Professional Recording Quality
- "Non-Glare" T.V. Finish

FOR THE PROFESSIONAL BROADCASTING • TELECASTING • RECORDING STUDIO

Designed to meet the requirements of the professional, Altec's new 684A microphone offers the latest acoustical developments in dynamic microphone design. Its excellence in performance and reliability will satisfy the most critical broadcast or sound engineer. The polar pattern of the 684A is omnidirectional, output level is an extremely efficient -55 db/10 dynes/cm², and response is uniform from 35 to 20,000 cycles.

The model 684A is a truly professional-type unit, one of a series of new Altec microphones incorporating the exclusive *Golden Diaphragm*. This newly developed diaphragm of Mylar® polyester provides wide range and uniform frequency response as well as being highly resistant to shock or blasts, and is unaffected by corrosive chemical fumes. Both the diaphragm and the pressure element are fully protected from dirt, moisture, or foreign particles by another Altec exclusive, a rugged, sintered bronze filter located at the sound entrance.

A slip-on adapter is supplied with the microphone to permit quick and easy removal from the stand. Finish is two-tone green and black enamel that prevents unwanted glare when the microphone is used before the television camera. The various output impedance values, 30/50, 150/250 and 20,000 ohms, may be selected in the cable plug. Each unit comes complete with 15 feet of 2-conductor shielded cable, a slip-on adapter, an individual calibration curve is included and an attractive hand-rubbed wood storage case.



A Subsidiary of Ling-Temco Electronics, Inc.

1515 S. Manchester Ave., Anaheim, Calif.

New York, Los Angeles

PERFORMANCE SPECIFICATIONS:

Type:	Moving Coil Dynamic
Pickup Pattern:	Omnidirectional
Frequency Response:	35 to 20,000 cycles
Output Impedance:	30/50, 150/250 and 20,000 ohms (selection by connections in microphone cable plug)
Output Level:	-55 dbm/10 dynes/cm ²
Hum:	-120 db (Ref.: 10 ⁻³ Gauss)
Dimensions:	1½" diameter at top (1½" largest diameter) 7½" long not including plug
Weight:	8 ozs. (not including cable and plug)
Finish:	Two-tone baked enamel, black and dark green
Mounting:	Separate "Slip-On" adapter No. 13338 furnished. Adapter has standard ⅝" — 27 thread.
Accessories:	See "Microphone Accessories" sheet for desk or floor stands, on-off switches, adapters, and other microphone accessories.

ARCHITECTS AND ENGINEERS SPECIFICATIONS

The microphone shall be of the dynamic moving coil type having the following specifications. The microphone shall have a diaphragm of Mylar® to provide full protection against extreme shock and blasts. The diaphragm shall withstand exposure to temperature variations from -20 degrees F to 160 degrees F and shall not be susceptible to the effects of corrosive fumes. The microphone sound entrance shall be protected by a sintered bronze filter to prevent water, moisture, dust or ferrous particles from contaminating the acoustical element. The frequency response shall be uniform from 35 to 20,000 cps. The case shall be dual conical taper in shape and shall not measure more than 1½" in diameter in its largest dimension and shall be no longer than 7½" excluding connector. The microphone shall be furnished complete with a slip-on adapter for mounting on a microphone stand. The output level shall be at least -55 dbm (SPL equals 10 dynes/cm²) and the output impedance shall be selectable at 30/50, 150/250 and 20,000 ohms balanced with respect to ground. Provisions shall be available in the microphone cable plug for selecting the required impedance. Individual factory calibration curve must be supplied.

This microphone shall be Altec Lansing Model 684A.

685A *Cardioid Microphone*

685A

Sintered

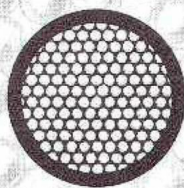

Bronze Filter

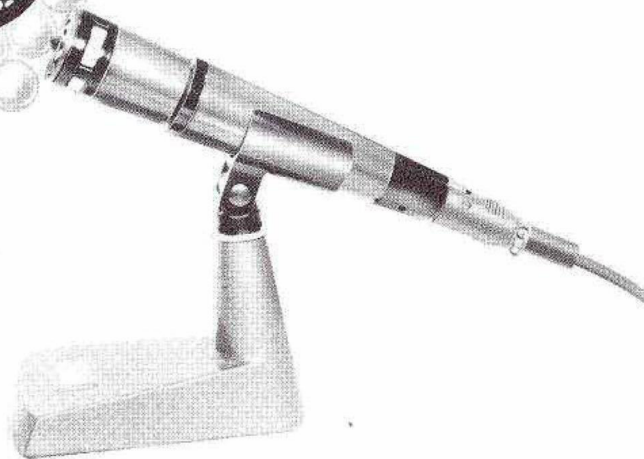

Features:

- Cardioid Pickup Pattern**
- Wide Response Range**
- Special Mylar® Diaphragm**
- Exclusive Altec Filter**
- Resistant to Shock and Blasts**
- Unaffected by Humidity Extremes**
- Withstands Temperature Variations**
- Highest Recording Quality**
- Sturdy Compact Styling**

FOR THE PROFESSIONAL TELECASTING • BROADCASTING • RECORDING STUDIO

Flat frontal response — a most desirable feature for professional sound equipment — has been fully realized in the model 685A Altec Cardioid Microphone. Response is 40 to 16,000 cycles with an average front-to-back discrimination of 20 db. the model 685A has less deviation throughout the audible spectrum of pick-up than heretofore available in any cardioid microphone.

The low resonance of the 685A is made possible by incorporation of the new Altec *Golden Diaphragm*. This diaphragm, made of Mylar® polyester, provides great resistance to shock or blast effects, assuring high quality sound pick-up under the most adverse conditions. It is even resistant to corrosive chemical fumes that might be encountered in service. The long diaphragm compliance section is the major factor in controlling the microphone's high sensitivity.

To withstand the operating conditions on broadcast stages and in recording studios the model 685A is further protected from contamination by moisture, dust, dirt, and ferrous particles, by Altec's sintered bronze filter.

The exterior design presents an attractive slim-line appearance and the microphone is finished in non-glare black and dark green enamel. Each microphone includes 15 feet two conductor cable and a slip-on adapter. An individual calibration curve is included with each unit.



A Subsidiary of Ling-Temco Electronics, Inc.

1515 S. Manchester Ave., Anaheim, Calif.

New York, Los Angeles

PERFORMANCE SPECIFICATIONS:

Type:	Cardioid Dynamic
Frequency Response:	40 to 16,000 cycles
Output Impedance:	30/50, 150/250 and 20,000 ohms (selection by connections in microphone cable plug)
Output Level:	-54 dbm/10 dynes/cm ²
Discrimination:	Average front to back, 20 db
Pickup Pattern:	Cardioid
Hum:	-120 db (Ref.: 10 ⁻³ Gauss)
Dimensions:	1½" diameter at top, 7 ¹³ / ₁₆ " long not including plug
Weight:	11 ozs. (not including cable and plug)
Finish:	Two-tone baked enamel, black and dark green
Mounting:	Separate "Slip-On" adapter No. 13339 furnished. Adapter has standard 5/8" — 27 thread.
Accessories:	See "Microphone Accessories" sheet for desk or floor stands, on-off switches, adapters, and other microphone accessories.

ARCHITECTS AND ENGINEERS SPECIFICATIONS

The microphone shall be of the Cardioid type employing the moving coil dynamic principle with a diaphragm of Mylar® having tangential compliance to provide full protection against extreme shock and blasts. The diaphragm shall withstand exposure to temperature variations from -20 degrees F to 160 degrees F and shall not be susceptible to the effects of corrosive fumes. The microphone sound entrance shall be protected by a two-stage filter composed of one sintered bronze and one cast screen to prevent water, moisture, dust, or ferrous filings from contaminating the acoustical element. The frequency response shall be uniform from 40 to 16,000 cps. The case shall be dual conical taper in shape and shall not measure more than 1½" in diameter in its largest dimension and shall be no longer than 7¹³/₁₆" not including connector.

The microphone shall be furnished complete with a slip-on adapter for mounting on a microphone stand. The output level shall be at least -54 dbm (SPL equals 10 dynes/cm²) and the output impedance shall be selectable at 30/50, 150/250 and 20,000 ohms balanced with respect to ground. The average discrimination between the front and back of the microphone shall be in the order of 20 db over the range of 40 to 16,000 cycles. The hum shall be no greater than -120 db (Ref.: 10⁻³ Gauss). Provisions shall be available in the microphone cable plug for selecting the required impedance. Individual factory calibration chart must be supplied.

This microphone shall be Altec Lansing Model 685A.

686A "Lavalier" Microphone

686A

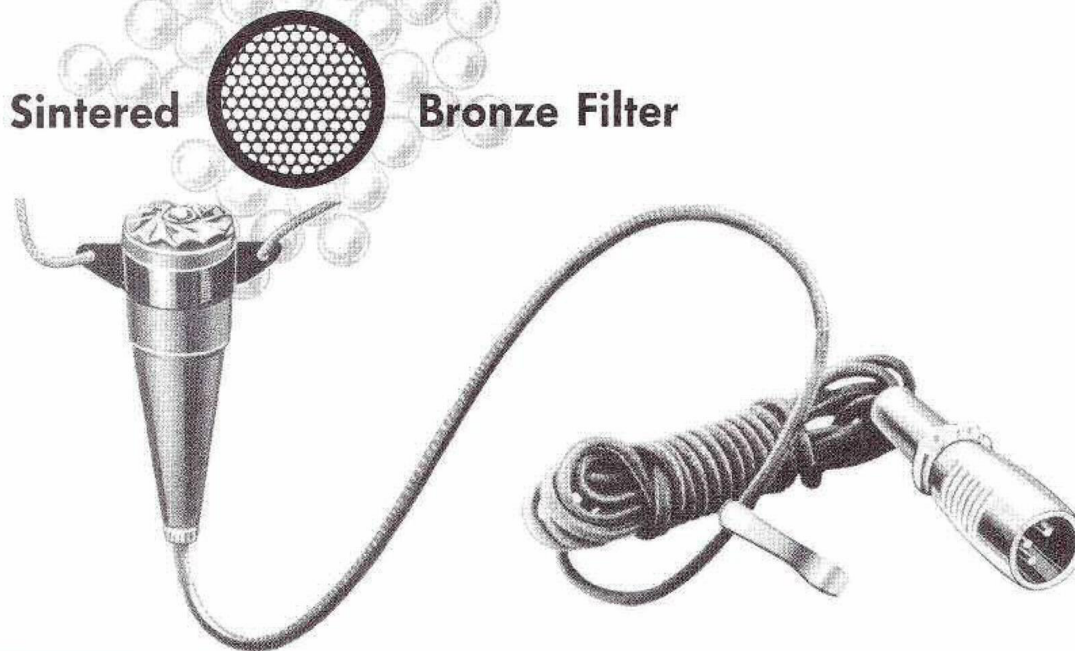

Sintered Bronze Filter

Features:

- Lavalier Type
- Light Weight — Small Size
- Extended Frequency Response
- Special Altec Mylar® Diaphragm
- Unaffected by Blast and Shock
- Filter of Sintered Bronze
- Dust and Moisture Proof
- Rugged Construction Throughout
- Neck Cord and Lapel Clip Furnished
- "Non-Glare" Enamel Finish
- Moderately Priced

PUBLIC SPEAKERS • ANNOUNCERS • BROADCASTING TELECASTING • HOME DEMONSTRATIONS

The new Altec model 686A Lavalier-type microphone is a miniature, dynamic unit with full frequency range, designed for those difficult applications necessitating microphone concealment, individual mobility, or freedom of hands and body. It has an integral snap-on neck cord and a steel spring clip for attachment to the speaker's clothing or may be hand-held, if desired.

Moderately priced, this microphone incorporates significant developments in styling and engineering. Attractive, small in size — the ultimate in reliability and performance. Equipped with Altec's *Golden Diaphragm* of rugged Mylar® polyester, the 686A exhibits exceptionally smooth response over a wide range of 70 to 20,000 cycles. This diaphragm is highly resistant to the effects of blast or shock and not affected to chemically corrosive atmospheres.

Another Altec Exclusive, a sintered bronze filter, provides even more extensive protection of the acoustical element by prohibiting the entrance of any foreign particles or moisture into the microphone proper.

The model 686A Lavalier-type microphone has been designed for consistent and dependable performance on a professional level. It is ideally suited for use in broadcasting, and telecasting, participation shows, public speaking, man-in-the-street interviews or home demonstrations. Finish is a dark green, non-glaring enamel allowing unrestricted use in the television studio.



A Subsidiary of Ling-Temco Electronics, Inc.

1515 S. Manchester Ave., Anaheim, Calif.

New York, Los Angeles

PERFORMANCE SPECIFICATIONS:

Type:	Moving Coil Dynamic "Lavalier" Microphone
Frequency Response:	70 to 20,000 cycles used as a "Lavalier"
Output Impedance:	30/50 and 150/250 ohms (selectable by connections in plug at end of microphone cable)
Output Level:	-55 dbm/10 dynes/cm ²
Pickup Pattern:	Omnidirectional
Hum:	-120 db (Ref.: 10 ⁻³ Gauss)
Dimensions:	1 ³ / ₈ " diameter at top tapered to ³ / ₈ " at cable entrance, 3 ¹ / ₂ " long
Weight:	3 ozs. (not including cable and plug)
Finish:	Baked enamel, non-glare dark green
Mounting:	"Snap-on" Lavalier neck cord No. 13356 and spring type tie or lapel clip No. 13322. Microphone complete with 20 foot, 3-conductor shielded cable and plug.
Accessories:	See "Microphone Accessories" sheet for desk or floor stands, on-off switches, adapters, and other microphone accessories.

ARCHITECTS AND ENGINEERS SPECIFICATIONS

The microphone shall be of the dynamic moving coil type having the following specifications. The microphone shall have a diaphragm of Mylar® with tangential compliance to provide full protection against extreme shock and blasts. The diaphragm shall withstand exposure to temperature variations from -20 degrees F to 160 degrees F and shall not be susceptible to the effects of corrosive fumes. The microphone sound entrance shall be protected by a sintered bronze filter to prevent water, moisture, dust or ferrous particles from contaminating the acoustical element. The frequency response shall be uniform from 70 to 20,000 cps when used as a "Lavalier." The case shall be conical in shape and shall not measure more than 1³/₈" in diameter at the top, tapered to ³/₈" at the cable entrance and shall be no longer than 3¹/₂". The microphone shall be furnished complete with a snap-on lavalier neck cord and spring-type tie or lapel clip, and shall be complete with a 20 foot, 3 conductor shielded cable and plug. The output level shall be at least -55 dbm (SPL equals 10 dynes/cm²) and the output impedance shall be selectable at 30/50 and 150/250 ohms. Provisions shall be available in the microphone cable plug for selecting the required impedance.

This microphone shall be Altec Lansing Model 686A.

Microphone Accessories



6A



25A

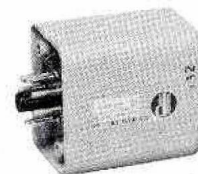

4665

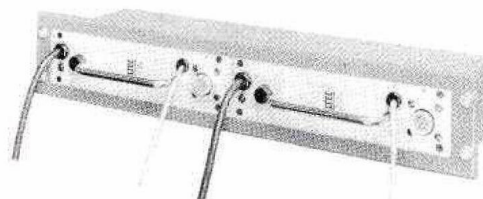

11853

25A DESK STAND

A modern, sturdy stand sufficiently stable for the heaviest microphone. The base is machined to accept the 5A Microphone Switch Kit. Has $\frac{5}{8}$ "-27 thread and $\frac{5}{8}$ "-24 adapter. Finished in dark Altec green.

25B DESK STAND

Identical to 25A but not machined for microphone switch.

5A MICROPHONE SWITCH KIT

Designed to assemble in base of 25A Desk Stand. Incorporates two single-pole, double-throw silver microswitches operated by single press-to-talk, or lock-to-talk slider. Will control both microphone and remote relays.

6A MICROPHONE SWITCH

Has same facilities as 5A Kit incorporated in stand mounting case. Fits between mike and stand. 1" diameter, $4\frac{3}{8}$ " length. Brushed chrome.

167A EXTENSION CABLE

Rugged 25' extension cable with connectors for use with M-20 and M-30 Microphone Systems between base and power supply.

168A WIND SCREEN

For use with 21 type microphones for wind noise suppression under extreme conditions.

170A WIND SCREEN

For use with 29A Condenser Cardioid for suppression of wind noise.

1883-H6 MICROPHONE CABLE

Slender, glass covered, highly flexible six-conductor cable as supplied with microphone bases in M-20 and M-30 Microphone Systems. For custom made extension cables. Order required length.

5426 MICROPHONE CABLE

Extremely rugged, heavy six-conductor cable for heavy duty extensions between condenser microphone bases and power supplies in M-20 and M-30 Microphone Systems. Order required length.

4665 PLUG-IN TRANSFORMER

Provides balanced 30, 150 and 600 ohm output from 525 and 526 Power Supplies in M-20 and M-30 Microphone Systems. $2\frac{5}{16}$ " h, 2" w, $1\frac{1}{2}$ " d.

11853 RACK MOUNTING ASSEMBLY

Provides standard relay rack mounting for two 525 or 526 type power supplies as used in the M-20 and M-30 Microphone Systems. Occupies only two units of rack space ($3\frac{1}{2}$ ").

12478 "LAVALIER" NECK CORD

Available on request for use with M-20 or 680A Microphones.



1515 S. Manchester Ave., Anaheim, Calif.

New York, Los Angeles



22C floor stand

Heavy weight, rugged floor stand, gray base with chrome stand. Adjustable from 35" to 64". Has 3/8"-27 thread and is equipped with 3/8"-24 adapter.



24C desk stand

Gray finish. Short desk stand provides minimum microphone height on speakers' tables, etc. Has 3/8"-24 thread and adapter for 3/8"-27 thread.

MICROPHONE ACCESSORIES For 639, 633, 632C



311A plug

For use in 633 and 632 microphones, makes it possible to interchange these microphones with the 639.

712A adapter

Used with 442A Jack, it provides greater mounting security.

8B attachment

3 1/4" baffle provides semidirectional response from 633 Microphone.

11A attachment

Provides swivel, suspension mounting for the 639 Microphone. It may also be used on microphone stands when tilting of the microphone is desired. Has 3/8"-24 male thread.

713A adapter

This slotted connector permits the microphone cord to run outside of the microphone stand so that it is not necessary to disconnect the cord assembly when removing the microphone from the stand.

442A jack

Provides termination of microphone cord. When used with 712A Adapter, it properly connects to bottom of 639 Microphone and also to 311A Plug as used on 633 and 632 microphones.

9A swivel attachment

Is used with 633 and 632 microphones. Provides a 90 degree swivel. May be attached directly to microphone or used with 311A Plug, 442A Jack, and 712A Adapter. Has 3/8"-24 male thread.

10994 adapter

For use in mounting 632C and 633 Microphones to W. E. telephone-type stand.

KS-12,000 cover

Black, dust-proof cover for protection of 639 Microphone.

23A desk stand

Slender desk stand particularly adapted for use with 633 or 632 microphone. Has 3/8"-24 female thread.

Dimensions: Height 7 1/2"
Diameter 5"

172A repeating coil

High quality impedance matching device for use in low level circuits, particularly between microphone and amplifier.

Frequency range: 30 to 15,000 cycles
Power capacity: .045 watts (+16 dbm) at 30 cycles
Insertion loss: approximately 1 db
Dimensions: Length 2 7/8"
Diameter 1 3/4"
Weight: 12 ozs.
Finish: Black

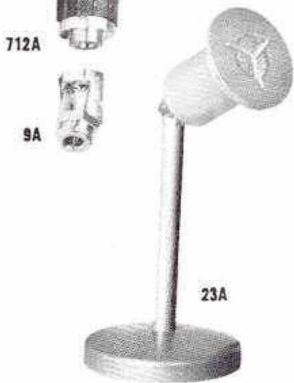

306A AM-FM Tuner

306A

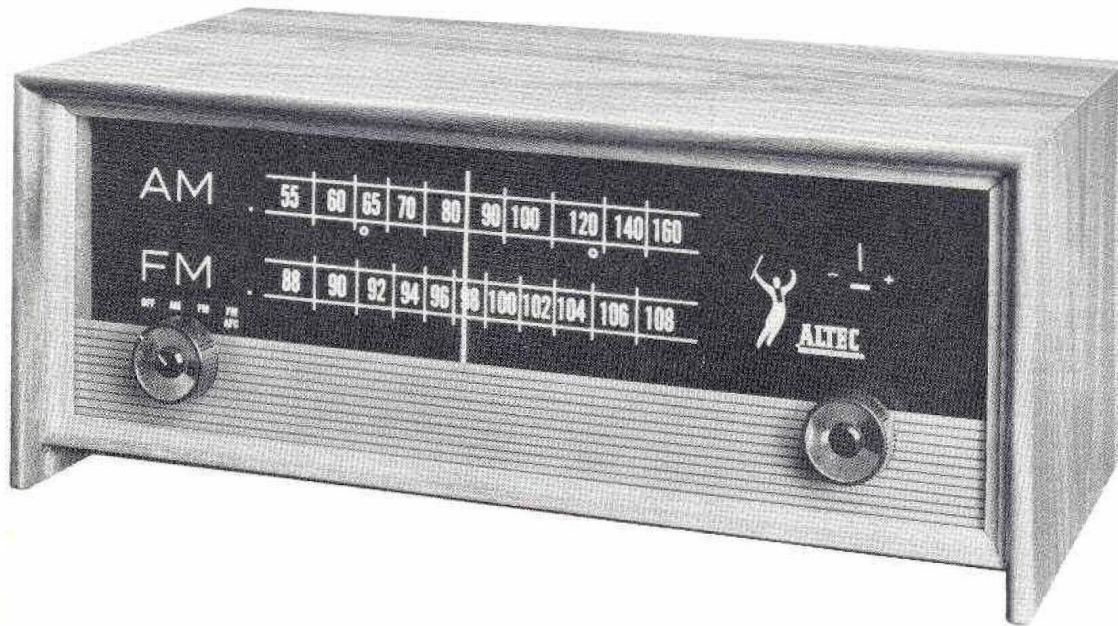

- Outstanding sensitivity**
- Low distortion**
- Drift free**
- AFC selection**
- Foster-Seeley circuit**
- Exceeds FCC requirements**
- Built-in AM antenna**
- Illuminated tuning meter**
- Perfect selectivity**
- Outstanding appearance**

The Altec 306A Tuner represents far more than a quality source for background music in a modern industrial sound system. This outstanding unit was designed by Altec engineers with complete cognizance of the demands and requirements of professional users both in public address and background music applications and in studios and laboratories where a standard monitor is required. This extra care has resulted in a tuner of extreme stability which does not "drift" off station and require re-tuning. Of equally great importance is the outstanding sensitivity of the 306A which permits clean reception of distant weak stations and, as a result, provides a much wider program selection. It is one of the few tuners built to a quality standard which meets the radiation requirements of the Federal Communications Commission.

Electrically this tuner consists of a quality Foster-Seeley (Armstrong) detector circuit, a "cascode" low noise RF stage, a triode low noise mixer stage, AFC and two limiter stages. The AM section uses specially designed IF transformers which are over-coupled for maximum band width and extreme skirt attenuation to give highest AM quality. This outstanding circuit has been carefully rendered on the chassis so that no quality loss is incurred and the tuner is given extensive testing and alignment to assure its performance.

The uses of a quality tuner in industrial sound systems are manifold. It provides a wide selection of background program material, can be used for the reception of events of general interest such as the World's Series and in an emergency will provide general dissemination of Civil Defense broadcasts.

The 306A may be rack mounted, built-in or mounted in a hardwood cabinet which is available in walnut, blond or mahogany. It will be found an indispensable part of any modern music, paging, public address system.



1515 S. Manchester Ave., Anaheim, Calif.

New York, Los Angeles

SPECIFICATIONS

Output:	1 volt cathode follower circuit
Tubes:	Two 6BQ7A, one 6AB4, three 6BA6, two 6AU6, one 6AL5, one 6BE6, one 12AU7
Controls:	Tuning, and selector switch for on-off, AM, FM, and FM-AFC
Power Supply:	117 volts, 60 cycles AC, 65 watts
(for FM)	
Antenna:	Standard 300 ohm
Maximum Sensitivity:	1.1 microvolt
Quieting Sensitivity:	2.5 microvolts for 20 db, with 300 ohm antenna 4.0 microvolts for 30 db, with 300 ohm antenna
Selectivity:	6 db band width 185 kc, 20 db band width 300 kc
Frequency Range:	87-109 megacycles
Image Rejection:	48 db
IF Rejection:	72 db
Frequency Response:	± 0.5 db, 20-20,000 cps
Distortion:	Less than 1% at 100% modulation less than 0.4% at 1 volt output
(for AM)	
Antenna:	Built-in "loopstick" Ferrite Rod, plus external antenna connections
Maximum Sensitivity:	3 microvolts
Loop Sensitivity:	50 microvolts per meter
Selectivity:	6 db band width 110.0 kc 40 db band width 27 kc
Frequency Range:	534-1675 kilocycles
Image Rejection:	66.5 db
IF Rejection:	58.5 db
Distortion:	Less than 1.5% at 30% modulation
Dimensions:	Chassis: 14" W, 8½" D, 5" H Occupies rack space 5¼" H
Weight:	14 lbs.
Color:	Cadmium plated chassis
Accessories:	Altec 12542 wood cabinet in walnut, blond, or mahogany; or rack mounting assembly model 12450.

ACCESSORIES

See "Power Amplifier Accessories" sheets for cabinets and rack mounting facilities.

ARCHITECTS AND ENGINEERS SPECIFICATIONS

The AM-FM tuner shall be the product of a well known manufacturer who shall have had at least ten years' experience in the design and manufacture of electronic and acoustic devices. The tuner shall be equipped for rack mounting and as such shall measure 5¼" H, 19" W, 8½" D, and shall weigh in the order of 14 pounds. There shall be included one tuning control and one selector switch for on-off operation and selection of AM, FM, and FM-AFC. The dial panel shall be illuminated. The tuner shall employ the 1 volt cathode follower type output, and cover the broadcast range of 87-109 megacycles on FM, and 534-1675 kilocycles on AM.

Any tuner of the so-called "home receiver" type and not meeting these specifications shall not be acceptable under these specifications. The tuner shall have an FM sensitivity of 1.1 microvolt maximum, and a quieting sensitivity of 2.5 microvolts for 20 db or 4.0 microvolts for 30 db quieting on a standard 300 ohm antenna. Any tuner or receiver whose specifications are based on a 72 ohm antenna circuit shall not be acceptable under these specifications.

The tuner shall be self-powered and not obtain any of its operating voltages from separate power supplies or any associated units in the system. The tube complement shall be two 6BQ7A and one 6AB4, three 6BA6, two 6AU6, and one each 6AL5, 6BE6 and 12AU7.

The tuner shall be Altec Lansing Model 306A, complete with mounting facilities.

128A Amplifier

128A



- 30 watts
- Class AB₁ circuit
- Tube testing facilities
- Wide frequency response
- Low distortion
- Low noise level
- Stepped gain control
- Easy servicing

The Altec 128A is a 30 watt power amplifier of exceptional quality for professional application in recording, broadcast and television studios and for use in the very finest public address systems where its professional quality and operational features can be utilized.

This precision built amplifier uses a conservative class AB₁ circuit, has a tube testing meter and circuit, and a detented gain control having twenty accurate steps of 2 db each.

The 128A has a frequency response of ± 1 db from 5 to 50,000 cps and a total harmonic distortion of less than $\frac{1}{2}\%$ over the range of 30 to 20,000 cps at 15 watt power output. At full 30 watt power output the harmonic distortion is less than 2% over the same frequency range.

As supplied the amplifier has an input impedance of 100,000 ohms. An accessory plug-in transformer will provide source impedances of 125/150 and 500/600 ohms. A wide variety of output impedances including the popular 70 v line are provided.

The amplifier has a hinged front panel which, when opened, gives convenient access to the interior for inspection and servicing and provides a shelf for test gear.

The 128A amplifier will be found without equal for those applications where quality and performance continuity are prime requisites.



1515 S. Manchester Ave., Anaheim, Calif.

New York, Los Angeles

SPECIFICATIONS

Gain:	68 db
Input Sensitivity:	.66 volts rms for rated output
Power Output:	30 watts at less than 2% thd, 30-20,000 cps 15 watts at less than ½% thd, 30-20,000 cps
Frequency Response:	± 1 db, 5-50,000 cps
Input Impedance:	10,000 ohm potentiometer
Source Impedance:	125/150, 500/600 ohms with 15095 or 4665 plug-in transformer
Load Impedance:	16 ohms grounded, 150 ohms (70 v line) balanced, 270 ohms grounded, 600 ohms with CT balanced
Output Impedance:	Less than 20% of nominal load impedance
Noise Level:	-30 dbm: 80 db below rated output
Controls:	Volume control, 20 steps, 2 db per step, last step infinity, with detent
Power Supply:	117/125 volts, 50/60 cps, 140 watts
External Power Available:	385 v dc at 10 ma, 6.3 vac at .6 a.
Tubes:	Two 6CG7, two 6CA7 or EL34, one 5U4GB
Dimensions:	8¾" H, 19" W, 8" D
Color:	Green
Weight:	18 lbs.

ACCESSORIES

15095 "Plug-in" Transformer

ARCHITECTS AND ENGINEERS SPECIFICATIONS

The amplifier shall be of the rack mounting type measuring not more than 8¾" H, 19" W, and 8" D. The amplifier shall include a meter and necessary switching to inspect performance of each vacuum tube. There shall also be a detented volume control having 20 steps of 2 db per step, the last step infinity. Any amplifier not including these features or utilizing a separate tube condition meter or a continuously variable volume control shall not be acceptable under these specifications.

Power output shall be 30 watts with less than 2% total harmonic distortion over the frequency range 30 to 20,000 cycles or 15 watts at less than ½% total harmonic distortion over the same frequency range. The frequency response shall be ± 1 db from 5 to 50,000 cycles. The noise level shall be -37 dbm 80 db below rated output. The overall gain of the amplifier shall not be less than 68 db. The output impedance shall be not more than 20% of the nominal load impedance. The load impedance shall be 16 ohms grounded, 150 ohms (70 v line) balanced, 270 ohms grounded, 600 ohms with center tap. The input shall be (choose one) (A) 100,000 ohms potentiometer, or (B) plug-in transformer with not less than 30 db shielding presenting impedances of 125/150 and 500/600 ohms. The power supply shall be 105 v, 117 v, and 125 v.

The power amplifier shall be capable of supplying external voltage of 385 v dc at 10 ma, 6.3 vac at .6 a, and shall not draw more than 140 w from the primary circuit. The tube complement shall consist of two 6CG7, two 6CA7 or EL34, one 5U4GB. The unit shall have provisions for use with a separate preamplifier of proper design. The unit shall be finished in green. The unit shall weigh in the order of 18 pounds.

Any power amplifier which does not have a tertiary winding in the output transformer for isolation of the output circuit from amplifier ground shall not be deemed acceptable under these specifications. Any amplifier using 6L6 or 6L6G tubes in the output stage shall be deemed unsatisfactory under these specifications.

The amplifier shall be Altec Lansing Model 128A.

260A Amplifier

260A

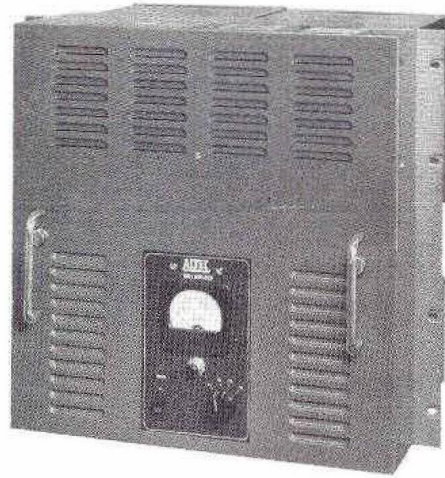

260 watts continuous

Efficient circuitry

Low cost per watt

Only 7 tubes

Automatic warm-up

High voltage safety protection

Remote or local control

117 v output for

motor operation

Utmost reliability

This amplifier will deliver 260 watts of low distortion power over a wide frequency range. This high specified power is available CONTINUOUSLY at 2% or lower distortion over the entire spectrum. Every care has been taken in its design to meet the safety, quality and reliability requirements of large public address and industrial sound systems and the specialized needs of industrial control and laboratory applications.

Output voltage regulation is held to less than 1 db. Output connections will accommodate conventional low impedance speaker loads, 70 volt distribution lines, and will provide 140 volts or 117-125 volts for the operation of motors at controlled frequencies.

An automatic delay relay in the power circuit assures an adequate warm-up period for the main tube complement without operator supervision and also makes it possible to install fully remote on-off control. Complete safety from high voltages is assured the operator by an interlock switch on the front cover which automatically turns off the amplifier when the cover is removed, and by bleeders on the high voltage condensers.

The carefully engineered circuit is exceptional in its simplicity using only seven high capacity broadcast type tubes instead of a large quantity of small receiver tubes. This circuit simplicity is important from the standpoint of reliability, maintenance and the cost of spares and replacements.

For high powered public address, music and industrial sound systems the 260A will be found far more reliable and economical than a number of smaller amplifiers. In industrial control use its extreme stability and high continuous rating make it the obvious choice for the operation of motors and shake tables at selected frequencies. The 260A is designed for standard relay rack mounting and there is an accessory cabinet available for wall mounting.



1515 S. Manchester Ave., Anaheim, Calif.

New York, Los Angeles

SPECIFICATIONS

Gain:	50 db; 30 db, bridging 600 ohm line
Input Sensitivity:	1.2 v rms/600 ohms
Power Output:	260 watts @ less than 2% thd, 45 cycles—15 KC
Frequency Response:	@ 10 watts, ± 0.5 db, 20-20,000 cps; ± 3 db, 5-70,000 cps
Source Impedance:	500/600 ohms and 5,000 ohms bridging
Load Impedance:	9, 19 (70 v line), 65 (130 v line) ohms
Output Impedance:	Less than 12% of nominal load impedance
Noise Level:	-16 dbm; 70 db below rated output
Controls:	Meter switch—Plate current balance
Power Supply:	105/117/125 volts, 60 cycles, 600 watts
Tubes:	Two 6AU6, two 813, two 3B28, one 5R4GYA
Dimensions:	18" H x 19" W x 14 $\frac{1}{4}$ " D
Color:	Green
Weight:	186 lbs.

ACCESSORIES

12156 wall mounting assembly

ARCHITECTS AND ENGINEERS SPECIFICATIONS

The amplifier shall be of the rack mounting type measuring not more than 18" H, 19" W, and 14 $\frac{1}{2}$ " D. Provisions shall also be available for wall mounting. It shall be equipped with interlock switch to disconnect the high voltage supply whenever it becomes necessary to expose any of the components. This safety feature shall be augmented by automatic filament warm-up delay relay enabling remote on and off control of the amplifier. Instantaneous on-off control of tube plates shall be available by installing proper external relays. The amplifier shall include a meter and necessary switching for checking plate current balance. The meter and switch shall be mounted on the control panel attached to the amplifier and located in the center of the front safety cover. This panel shall also include a pilot light and an on-off switch. Any amplifier not including these features or utilizing a separate tube condition meter shall not be acceptable under these specifications.

Power output shall be 260 watts with less than 2% total harmonic distortion over the frequency range of 45 to 15,000 cycles. The frequency response at 10 watts shall be $\pm .5$ db from 20 to 20,000 cycles and ± 3 db in the range from 5 to 70,000 cycles. The noise level shall be -16 dbm; 70 db below rated output. The overall gain of the amplifier shall be 50 db; 30 db bridging 600 ohm line. The output impedance shall be 9, 19 (70 v line), 65 (130 v line) ohms. The output impedance shall be less than 12% of nominal load impedance. Output connections shall provide for low impedance speaker loads, 70 v line, and a 65 ohm tap for 140 v line or 117-125 v to operate motors at various frequencies. The source impedance shall be 500/600 ohms and 5,000 ohm bridging. The power amplifier shall have selectable primary voltage taps of 105/117/125 v, 60 cycles, and shall not draw more than 600 W from the primary source. The tube complement shall consist of two 6AU6, two 813, two 2B28, one 5R4GYA. The unit shall be finished in green and shall weigh in the order of 186 pounds.

Any power amplifier which does not have a tertiary winding in the output transformer to free the load circuit from the amplifier ground shall not be deemed acceptable under these specifications.

The amplifier shall be Altec Lansing Model 260A.

342A Amplifier

342A



20 watt output

Four inputs

Input matchers for every
type source

High fidelity quality

Full mixing facility

Master gain control

Bass & treble tone controls

Illuminated panel

Neat appearance

DC hum-free heaters

The Altec 342A 20 watt Amplifier and Mixing Preamplifier has a flexibility which makes it ideal for any small public address system. It can be quickly tailored to the exact requirements of any installation. There are four inputs, each with individual mixing volume controls. Any possible combination of four inputs can be used because of the unique "input matcher" facility of this amplifier.

The input circuit of each of the four channels is equipped with a socket which will receive the necessary accessory to adapt that channel to the desired source: high or low impedance microphone, crystal or equalized magnetic phonograph pickup, tuner, tape recorder or program line. This not only provides great flexibility in the initial installation but also makes it possible to modify or change the system to meet future requirements.

In addition to the four volume controls for these inputs, there is a master control which functions on the final selected program material from all inputs, separate bass and treble raise and cut tone controls, an independent power switch and a cue light which illuminates the panel and provides illumination for scripts or cue sheets.

The dark green non-reflecting panel and green leatherette case are neat and unobtrusive and the amplifier will not interfere with the vision of the operator when placed on a table top. The front panel has been slanted for easy visibility and to place the controls at the most efficient position.

The quality of the 342A places it truly in the category of a high fidelity amplifier. Its DC operation of tube heaters insures hum-free performance and eliminates the need for tube selection. The quality, flexibility, intelligent electrical and mechanical engineering and price of the 342A Amplifier make it ideal for every public address system of moderate size whether permanent or portable.



1515 S. Manchester Ave., Anaheim, Calif.

New York, Los Angeles

SPECIFICATIONS

Gain:	115 db
Input Sensitivity:	.0023 volt rms for rated output
Power Output:	20 watts at less than 2.0% thd, 40-15,000 cps
Frequency Response:	± 1 db, 20-20,000 cps
Input Impedance:	Nominal 100,000 ohms
Source Impedance:	30/50 and 120/200 ohms with 4722 plug-in transformer
Load Impedance:	4, 8, 16 ohms and 70 v line
Output Impedance:	Less than 20% of nominal load impedance
Noise Level:	Equivalent input noise—123 db Output noise—37 dbm with master volume control at zero
Controls:	4 mixer controls, 1 master volume control, 1 each bass and treble raise and cut equalizer control; all cont. variable composition
Power Supply:	117 volts, 60 cps, 110 watts
External Power Available:	117 volt AC receptacle at rear of chassis
Tubes:	Three 12AD7 (or 12AX7), one 6CG7, two 6L6GB, one 5V4GA
Dimensions:	7" H, 19 $\frac{1}{2}$ " W, 8 $\frac{1}{8}$ " D
Color:	Green
Weight:	22 lbs.
Accessories:	4722 Plug-In Transformer 12227 Assembly—plug-in phono equalizer 12210 Assembly—rack mounting assembly Cannon XL-3-12 straight cord plug

ACCESSORIES

See "Power Amplifier Accessories" sheets for plug-in transformers, relay racks, mounting cabinets, and other amplifier accessories.

ARCHITECTS AND ENGINEERS SPECIFICATIONS

The amplifier shall be so constructed that it may be (choose one) (A) portable, in green simulated-leather covered plywood cabinet, or (B) rack mounted with an available accessory. The amplifier shall include 4 mixer controls, one master volume control, one each bass and treble raise and cut equalizer controls, pilot light, and on-off switch. All controls shall be continuously variable and the control panel shall be visibly indexed and identified. The amplifier shall be so designed that any of four mixer positions may be used with high impedance microphone or high level line input or, by use of available "input matchers", any or all of the mixer positions can be converted for low impedance microphones, or equalized for phonograph input. An amplifier not including these "input matcher" facilities shall not be deemed acceptable under these specifications.

Power output shall be 20 watts with less than 2% total harmonic distortion over the frequency range of 40 to 15,000 cycles, the frequency response shall be ± 1 db from 20 to 20,000 cycles, input impedance shall be a nominal 100,000 ohms with source impedance of 30/50 or 120/200 ohms through proper impedance matcher. The over-all gain of the amplifier shall be not less than 115 db. The output impedance shall be less than 20% of nominal load impedance. Load impedance shall be 4, 8, 16 and 70 v line.

The low impedance microphone "input matcher" where required shall be of the plug-in type with not less than 60 db magnetic shielding, the equivalent input noise —123 dbm, output noise —37 dbm with master volume control at zero. The amplifier shall have a receptacle on the rear of the chassis for furnishing 117 v AC. The tube complement shall consist of three 12AD7 (or 12AX7), one 6CG7, two 6L6GB, one 5V4GA. The unit shall be finished in green and shall weigh in the order of 22 lbs.

Any power amplifier which does not have a tertiary winding in the output transformer for isolation of the output circuit from ground shall not be deemed acceptable under these specifications.

The amplifier shall be Altec Lansing Model 342A.

350A Power Amplifier

350A



- 40 clean watts
- Low distortion
- Extreme frequency range
- Table or shelf mounting
- 25 v and 70 v output
- Quiet operation
- Simple circuitry
- Highest quality amplification
- Facility for plug-in line transformer

The 350A is a compact, 40 watt, class AB₁ power amplifier of wide band width, low distortion, and very quiet operation. It is excellent for any public address system requiring up to 40 watts of highest quality amplification.

Simple, precise circuitry of proven performance eliminates need for critical adjustments in the field. Trouble-free operation is assured by top quality components and a generous performance margin. Premium output tubes with gold plated grids, rated for 100 watt capacity, are conservatively operated at 40 watts. Heavy Peerless Transformers extend power capabilities in the high frequencies and assure freedom from distortion through the entire range.

A power switch and fully calibrated gain and R/R_c controls are located on an attractive escutcheon plate at the front of the unit. Output terminals directly match speaker impedances. Additional outputs are provided for 25 v and 70 v speaker distribution systems. The input system provides high impedance direct connection. An Altec 15095 plug-in line transformer, available as an accessory, converts the 350A to balanced or unbalanced 125/600 ohm input for use from line or other low impedance source.

This shelf or table mounting amplifier is recommended for any small or medium public address facility where quality, durability, and complete stability, even under the most unfavorable conditions, are requisite.



1515 S. Manchester Ave., Anaheim, Calif.

New York, Los Angeles

SPECIFICATIONS

Gain:	66.5 db from 60,000 ohm generator or from line with plug-in transformer
Input Sensitivity:	.75 volts rms for 40 watts output
Power Output:	40 watts at less than 0.5% total harmonic distortion (within 0.5 db 25-20,000 cps)
Frequency Response:	± 1 db 5-100,000 cps
Input Impedance:	200,000 ohm potentiometer
Source Impedance:	150 and 600 ohms with plug-in line transformer
Load Impedance:	8, 16, 125 ohms 18, 25, 70 volts
Output Impedance:	Continuously adjustable .14 to 7.5 times nominal load impedance on 8 and 16 ohm taps. Less than 10% of nominal load impedance on 70 volt line tap.
Damping Factor:	Continuously adjustable 7 to .13 on 8 and 16 ohm taps
Noise Level:	-40 dbm: 86 db below full output
Controls:	Gain control, R/R _c control, power switch
Power Supply:	117 volts, 60 cps, 160 watts
External Power Available:	117 volt ac receptacle on chassis
Tubes:	1 - 12AY7, 1 - 12AU7, 2 - 6550, 1 - 5U4GB, 1 - OA3/VR75
Dimensions:	7" H, 9 $\frac{5}{8}$ " W, 13 $\frac{1}{4}$ " D
Color:	Dark green hammertone
Weight:	27 lbs.
ACCESSORY:	15095 Line Transformer

ARCHITECTS AND ENGINEERS SPECIFICATIONS

The amplifier shall be of the shelf mounting type and it shall be capable of delivering 40 watts continuously at a distortion of less than 0.5%, within 0.5 db at any frequency from 25 to 20,000 cps. Its frequency response shall be flat within ± 1 db from 5 to 100,000 cps, input sensitivity shall be .75 volt for full output and the noise in the output shall not exceed -40 dbm. The input impedance shall be that of a 200,000 ohm gain control and the amplifier shall accommodate a plug-in line input transformer for source impedances of 150 and 600 ohms; such a transformer shall be available as an accessory. Output terminals shall be provided for 8, 16 and 125 ohm loads, the corresponding line voltages being 18, 25 and 70 volts respectively. The output impedance for the 70 volt circuit shall not exceed 10% of the nominal load, and it shall be adjustable from .14 to 7.5 times the nominal loads for the 8 and 16 ohm outputs.

The power connection to the transformer shall be by a 3 conductor power cord equipped with a 3-pin cap and a receptacle shall be mounted on the chassis to provide 117 volt ac power to external equipment. Dimensions shall be 7" H by 9 $\frac{5}{8}$ " W by 13 $\frac{1}{4}$ " D, the amplifier shall weigh in the order of 27 lbs. and it shall be finished in dark green hammertone. It shall use the following tubes: 1 - 12AY7, 1 - 12AU7, 2 - 6550, 1 - 5U4GB and 1 - OA3/VR75.

The amplifier shall be the Altec Lansing Model 350A.

428B and 429B Preamplifiers

428B
429B

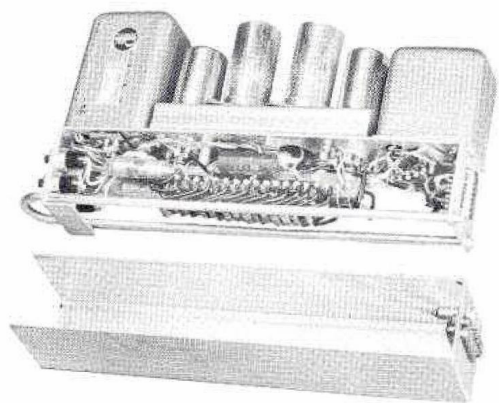

428B with 11301 Cover Tray
shown separately



429B with 11302 Cover Tray
shown separately



- Full broadcast quality
- ± 1 db, 20-20,000 cps
- Plug-in
- Tube testing facility
- Compact
- Low noise
- Low distortion
- Flexible
- Stable circuits

Designed to meet the full FCC requirements for quality broadcasting, these two outstanding miniature units are invaluable in the design and assembly of elaborate recording, public address and sound distribution systems. They are of the plug-in type and have gold plated contacts to assure perfect continuity when inserted in their accessory cover trays and mating receptacles. This plug-in facility allows rapid replacement of the entire unit in case of tube failure or other malfunction. In addition, push buttons are provided on the end of the units for use in testing individual tubes.

The Altec 428B is a straight-forward preamplifier having either 40 db or 34 db of gain to accommodate the highest microphone levels without distortion and the lowest levels at the ultimate signal-to-noise ratio. Its compact size makes it easy to install in custom consoles in whatever numbers are required. Its ± 1 db from 20 to 20,000 cps frequency response, low distortion and noise level and stable circuitry are compatible with the finest audio system.

The Altec 429B is a line or monitor amplifier of the same quality as the 428B. As a line amplifier it can be used for feeding program distribution lines, remote amplifiers or other comparable applications. Installed as a system monitor amplifier, it will deliver 8 watts of audio power with less than 1% harmonic distortion and when associated with an adequate speaker system will permit checking the content and quality of the program material.

Power for these units is obtained from the companion Altec 522B Power Supply which is of the same miniature size for compatible mounting. The reliable circuitry, stability of operation and rugged construction of these units virtually eliminates "down time" in broadcasting and recording and gives the same operational assurance when used in public address and sound systems.



1515 S. Manchester Ave., Anaheim, Calif.

New York, Los Angeles

428B SPECIFICATIONS

Gain:	40 db normal. May be connected for 34 db
Power Output:	+ 20 dbm at less than 1/2% thd, 50-15,000 cps + 20 dbm at less than 1% thd, 30-15,000 cps
Frequency Response:	± 1 db, 20-20,000 cps
Source Impedance:	30/50, 125/150, 250/300, 500/600 ohms. Center tap available for 125/150 and 500/600 ohm connections.
Load Impedance:	30/50, 125/150, 250/300, 500/600 ohms. Center tap available for 250/300 and 500/600 ohm connections.
Noise Level:	Output noise -80 dbm: 100 db below rated output Equivalent input noise -120 dbm
Controls:	Push button switches for testing tube currents using external meter (meter not supplied)
Power Supply:	260 vdc at 10 ma, 6.3 vac at 0.6 a.
Tubes:	Two 12AY7
Dimensions:	4 3/4" H, 1 1/2" W, 10" D
Color:	Cadmium plate
Weight:	3 lbs.
Accessories:	11301 cover tray and mating receptacle. Must be ordered separately.

429B SPECIFICATIONS

Gain:	50 db
Power Output:	Line amplifier connection, + 30 dbm at less than 1/2% thd, 30-15,000 cps. Monitor amplifier connection, + 39 dbm (8 watts) at less than 1% thd, 50-15,000 cps
Frequency Response:	± 1 db, 20-20,000 cps
Source Impedance:	30/50, 125/150, 250/300, 500/600 ohms. Center tap available for 125/150 and 500/600 ohm connections.
Load Impedance:	125/150 and 500/600 ohms. Center tap available for 500/600 ohm connection.
Noise Level:	-60 dbm: 90 db below rated line output, 99 db below rated monitor output
Controls:	Push button switches for testing tube currents using external meter (meter not supplied)
Power Supply:	270 vdc at 35 ma, 6.3 vac at 1.2 a. (line amplifier connection) 270 vdc at 70 ma, 6.3 vac at 1.2 a. (monitor amplifier connection)
Tubes:	One 12AY7, two 6AQ5
Dimensions:	4 3/8" H, 2 1/4" W, 10" D
Color:	Cadmium plate
Weight:	4 1/2 lbs.
Accessories:	11302 cover tray and receptacle. Must be ordered separately.

428B ARCHITECTS AND ENGINEERS SPECIFICATIONS

The power supply shall be of the plug-in type having provisions for mounting in a rack unit or frame which rack unit shall have a hinged front for rapid removal or insertion of the preamplifier into the circuit. Any preamplifier not including these features shall not be acceptable under these specifications.

Power output shall be + 20 dbm at less than 1/2% total harmonic distortion over the range from 50 to 15,000 cycles and + 20 dbm at less than 1% total harmonic distortion over the range of 30 to 15,000 cycles. The distortion shall not exceed these values with an input signal of -20 dbm.

The frequency response shall be ± 1 db from 20 to 20,000 cycles. The input transformer shall not have less than 90 db magnetic shielding. The noise level shall be -80 dbm: 100 db below rated output. The over-all gain of this preamplifier shall be 40 db normal with connections for 34 db gain. Source impedance shall be 30/50, 125/150, 250/300, 500/600 ohms. There shall be a center tap available for 125/150 and 500/600 ohm connections. The load impedance shall be 30/50, 125/150, 250/300, 500/600 ohms with a center tap available for 250/300 and 500/600 ohm connections.

Equivalent input noise shall be -120 dbm. There shall be push-button switches for testing tube currents by a separate external meter. The power requirements for this preamplifier are 260 vdc at 10 ma, 6.3 vac at 0.6 a. The power supply used in connection with this preamplifier shall be one having similar plug-in connections and shall have the same depth as the preamplifier. The tube complement shall be one 12AY7 and two 6AQ5. The unit shall be finished with cadmium plating and shall weigh in the order of 3 lbs.

This preamplifier shall be Altec Lansing Model 428B.

429B ARCHITECTS AND ENGINEERS SPECIFICATIONS

This (choose one) (A) line amplifier, or (B) monitor amplifier shall be of the plug-in type designed for use with a rack mounting assembly. The amplifier shall measure 4 3/8" H, 2 1/4" W, and 10" D, and the associated rack mounting assembly (where required) shall measure 7" H, 19" W, and 12 3/8" D. This rack assembly shall have a hinged front cover or mat to permit instantaneous removal or installation of this amplifier from the circuit. The amplifier shall be designed to mount in an associated cover and mating receptacle, and the amplifier shall include push-button switches for testing tube condition by use of an external meter. Any amplifier not including these features shall not be acceptable under these specifications.

The amplifier shall have a power output (choose one) (A) as line amplifier, + 30 dbm at less than 1/2% total harmonic distortion over the range of 30 to 15,000 cycles or (B) as monitor amplifier, + 39 dbm (8 watts) at less than 1% total harmonic distortion over the range of 50 to 15,000 cycles. The frequency response shall be ± 1 db from 20 to 20,000 cycles. The input transformer shall not have less than 90 db magnetic shielding. The noise level (choose one) (A) as line amplifier, -60 dbm, 90 db below rated line output, or (B) as monitor amplifier, 99 db below rated monitor output. The source impedance shall be 30/50, 125/150, 250/300, 500/600 ohms. There shall be a center tap available for 125/150 and 500/600 ohm connections. The load impedance shall be 125/150 and 500/600 ohms, with a center tap available for 500/600 ohm connections.

The power supply requirements for this amplifier shall be (choose one) (A) as line amplifier, 270 vdc at 35 ma, 6.3 vac at 1.2 a.; or (B) as monitor amplifier, 270 vdc at 70 ma, 6.3 vac at 1.2 a. furnished by a separate power supply. The tube complement shall consist of one 12AY7 and two 6AQ5. The unit shall be finished in cadmium plate and shall weigh in the order of 4 1/2 lbs.

The amplifier shall be Altec Lansing Model 429B.

436A & 439A Compressor Amplifiers

436A
439A



- Fast attack time**
- Smooth, quiet recovery**
- Wide frequency response**
- Compact**
- Fully automatic**
- Protects entire sound system**
- Rack, wall or table mount**
- Broadcast quality**
- 30 db of compression**
- Simple installation**

These two fully automatic level controlling amplifiers have a versatility which makes them a desirable part of the majority of audio installations. They will provide up to 30 db of compression with the ideal attack and recovery time for smooth reproduction without "thumps" or sudden level changes. The amplifiers can be used to control the level of a single channel, equalize level differences between a number of channels, or to provide automatic "fading" when a signal deserving precedence is introduced into the programming.

Among the more common uses of these outstanding units is automatic fading of background music during paging in industrial and commercial paging and music systems; minimizing the differences between different stations in telephone conference calls; controlling the difference in levels between performers or the difference in levels between different microphone positions in a paging system; controlling the differences in level between multiple program sources and the prevention of destructive overloading of amplifiers and loudspeakers by sudden high-level sounds.

These two compressor amplifiers are identical with the exception of input transformers, impedances and gain.

Since they are fully automatic, the only control provided is a power switch. The front panel also contains the fuse and a meter which indicates db of compression. The front panel is hinged and, when open, provides ready access to all components and wiring for easy service. For inexpensive installation, all connections are made to simple barrier type terminals on the rear of the amplifier. A three conductor power cord is pre-wired to the unit. For those installations where compression is only desired part time, these units will also operate as straight high quality line amplifiers when the 6AL5 tube is removed from its socket.

These compressor amplifiers occupy only 3½" of rack space in the standard Altec relay rack or may be mounted in the Altec 12495 cabinet for table or wall installations. For remote monitoring of the compression taking place in the amplifier, the Altec 6049 meter may be ordered for installation in the control console or at the announcing position.

The wide frequency range, low distortion, wide range of application and fully automatic operation of these new Altec compressor amplifiers make them an integral part of any good sound system.



1515 S. Manchester Ave., Anaheim, Calif.

New York, Los Angeles

SPECIFICATIONS

Type:	Compressor Amplifier
Gain:	436A — 54 db from 15,000 ohm source: 42 db bridging 600 ohm line 439A — 61 db from 30, 250 or 500 ohm source
Maximum Compression:	30 db (50 db change in input results in 20 db change in output)
Power Output:	+19 dbm at 30 db compression; +26 dbm as straight amplifier
Frequency Response:	±1.5 db, 30 to 15,000 cycles
Input Impedance:	436A — 15,000 ohms (unbalanced) bridging transformer 439A — Unterminated input transformer
Source Impedance:	436A — Any up to 15,000 ohms 439A — 30/50, 250/350, 500/600 ohms
Load Impedance:	150/600 ohms
Noise Level:	74 db below rated output: -111 dbm equivalent input noise
Controls:	AC power switch
Power Supply:	117 volts, 60 cycle, 20 watts
Tubes:	6BC8, 6CG7, 6AL5
Dimensions:	19" L, 3½" H, 6" D
Color:	Metallic Gray
Weight:	8½ lbs.
Special Features:	Compression meter
Attack Time:	50 milliseconds
Recovery Time:	1 second for 63% recovery
Harmonic Distortion:	at 25 db of compression, less than 1.5 %, 35 to 15,000 cps; at 30 db of compression, less than 2.5%, 35 to 10,000 cps

ACCESSORIES

12495 Cabinet, 6049 Meter

ARCHITECTS AND ENGINEERS SPECIFICATIONS

The compressor amplifier shall have a frequency response of ± 1.5 db from 30-15,000 cycles and it shall be capable of delivering a power output of +19 dbm at full compression (30 db), or +26 dbm as a straight amplifier. With 25 db of compression distortion shall not exceed 1.5% over the frequency range from 35 to 15,000 cps. The threshold point shall not be greater than zero dbm at the output and the amplifier shall provide 30 db compression. Attack time shall be fixed at 50 milliseconds and release time fixed at one second for 63% recovery.

The gain of the amplifier shall be (436A — 56 db from a 15,000 ohm source or 42 db bridging a 600 ohm line) (439A — 61 db from 30, 250 or 500 ohm source.) Input noise shall not exceed -111 dbm and the signal-to-noise ratio shall be at least 74 db. The input impedance shall be (436A — 15,000 ohm unbalanced bridging transformer.) (439A — an unterminated input transformer.) The load impedance shall be 150 or 600 ohms. The amplifier shall have a self contained power supply and be provided with a panel meter reading in db of compression. It shall be of the rack mounting type and shall also have provisions for mounting in a desk top type cabinet for remote operation where required. The unit shall measure 3½" H, 19" L, 6" D and weigh in the order of 8½ pounds. The tube complement shall be one 6BC8, one 6CG7 and one 6AL5. The hinged front panel shall be finished in metallic gray.

Any compressor not meeting these specifications as to the amount of compression or amplification or that does not permit the use of the compressor as a straight amplifier by the removal of one vacuum tube from its socket shall not be deemed acceptable under these specifications.

The compressor amplifier shall be Altec Lansing model (436A — 439A).

438A Compressor Amplifier

438A



Microphone preamplifier

Line amplifier

90 db gain

Two inputs

Fast attack

Smooth recovery

30 db of compression

Compact

Fully automatic

Simple installation

The 438A has been specifically designed for public address use but its outstanding quality also finds many broadcast, recording and communication applications. It is a dual purpose unit providing both high gain microphone preamplification and the complete facility of the Altec automatic compression line amplifier. Its gain and output are such that it will drive any Altec power amplifier to full output from the input of any quality dynamic microphone. Its unique compression assures high intelligibility and freedom from "blasting" or damage to the power amplifier and speakers due to sudden high-level sounds.

Operationally the 438A will compress signals as much as 30 db. This automatic compression with its rapid attack time of 50 milliseconds, can be used to compensate for the differences in loudness between users in paging or recording and to provide over-all system protection and smoothness. In addition to this microphone input there is a 600 ohm line bridging input for wired music and other program sources. The proper balancing of these two inputs results in automatic "fading" of background music material during paging. Use of the bridging input alone provides straight-forward compression of line program material. Removal of the 6AL5 tube from the circuit permits the 438A to operate as a simple microphone preamplifier and line amplifier without compression.

The hinged front panel of the 438A contains power switch, fuse, pilot light, gain control and compression meter. For remote monitoring of the compressing action the Altec 6049 meter may be ordered. When opened, the front panel exposes all components and wiring for easy service. All connections are made to simple barrier terminals on the rear of the unit. A three conductor power cord is pre-wired for ease of installation.

This outstanding multi-function unit occupies only 3½" of standard rack space or it may be table or wall mounted in the compact Altec 12495 cabinet. The high quality, fully automatic compressor operation and wide range of function are obtained in this Altec amplifier at an extremely low price which makes it economically sound to use the 438A instead of less effective simple preamplifiers and line amplifiers.



1515 S. Manchester Ave., Anaheim, Calif.

New York, Los Angeles

SPECIFICATIONS

Type:	Compressor Amplifier
Gain:	90 db from Microphone input; 40 db bridging 600 ohm line
Input Sensitivity:	6.5 millivolts on Bridging input to reach compression threshold
Maximum Compression:	30 db (50 db change in input results in 20 db change in output)
Power Output:	+19 dbm at 30 db compression; +24 dbm as straight amplifier
Frequency Response:	± 1.5 db, 40 to 10,000 cps
Input Impedance:	Bridging, 20,000 ohms unbalanced
Source Impedance:	Microphone input, 30/50 ohms
Load Impedance:	150 and 600 ohms
Noise Level:	Gain control at max., -119 dbm equivalent input noise, Microphone input Gain control at min., -50 dbm output noise level
Controls:	Gain, AC power switch
Power Supply:	117 volts, 60 cps, 22 watts
Tubes:	12AY7, 6BC8, 6CG7, 6AL5
Dimensions:	19" L, 3½" H, 6" D
Color:	Metallic Gray
Weight:	8½ lbs.
Special Features:	Compression meter
Attack Time:	50 milliseconds
Recovery Time:	1 second for 63% recovery
Harmonic Distortion:	At 25 db of compression, less than 1.5%, 30 to 15,000 cps At 30 db of compression, less than 2.5%, 35 to 10,000 cps

ACCESSORIES

12495 Cabinet, 6049 Meter

ARCHITECTS AND ENGINEERS SPECIFICATIONS

The compressor amplifier shall have a frequency response of ± 1.5 db from 30-15,000 cycles and it shall be capable of delivering a power output of +19 dbm at full compression (30 db), or +26 dbm as a straight amplifier. With 25 db of compression distortion shall not exceed 1.5% over the frequency range from 35 to 15,000 cps. The threshold point shall not be greater than zero dbm at the output and the amplifier shall provide 30 db compression. Attack time shall be fixed at 50 milliseconds and release time fixed at one second for 63% recovery.

The gain of the amplifier shall be 90 db from microphone input or 40 db bridging a 600 ohm line. Equivalent input noise shall not exceed -119 dbm at microphone input. The input impedance shall be 20,000 ohms (unbalanced) and for source impedance of microphone input 30/50 ohm. The load impedance shall be 150 or 600 ohms. The amplifier shall have a self contained power supply and be provided with a panel meter reading db of compression. It shall be of the rack mounting type and shall also have provisions for mounting in a desk top type cabinet for remote operation where required. The unit shall measure 3½" H, 19" L, 6" D, and weigh in the order of 8½ pounds. The tube complement shall be one 12AY7, one 6BC8, one 6CG7 and one 6AL5. The hinged front panel shall be finished in metallic gray.

Any compressor not meeting these specifications as to the microphone input, amount of compression, nor use as a straight amplifier shall be deemed unacceptable under these specifications.

The compressor amplifier shall be Altec Lansing model 438A.

522B and 523B Power Supplies

522B
523B

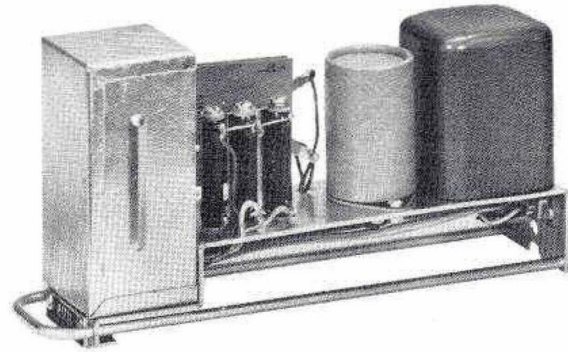
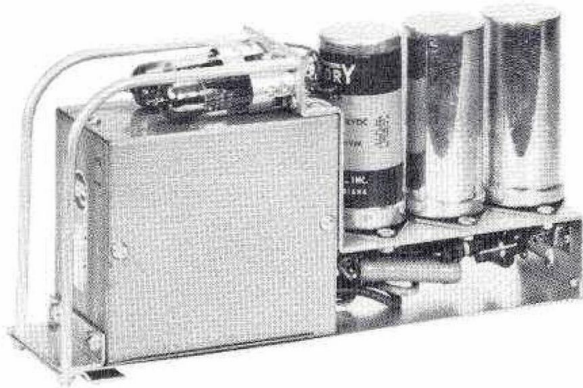

- Plug-in flexibility
- Exceptional quality
- Small size
- Gold plated contacts
- Wide application
- Latest circuitry

These two compact power supplies have been designed to meet the most stringent requirements of the broadcast industry. They are an integral part of the finest Altec audio consoles and find wide application in the input facility of better public address and sound distribution systems.

The 522B simultaneously provides both ac power at 6.3 v and dc power at 250-270 volts. One dc output supplies power at 0.2 v ripple for two 429B amplifiers, one operating as monitor and the other as line amplifier. A separate dc output supplies power at very low ripple voltages (0.001 v at 40 milliamperes) for up to nine 428B amplifiers.

The 523B power supply has been designed to operate the necessary accessories of any comprehensive system. It provides the necessary voltages to operate relays, pilot lights and other control circuits in custom equipment. In addition to these facilities the 523B contains three relays and load substitution resistors for monitor speaker muting in studio applications.

These two power supplies are of the "plug-in" type so that they can readily be removed for service inspection, thereby reducing system maintenance time and costs. The connector plugs are gold plated to insure continuous, noise-free contact without any chance for deterioration. The mating receptacle for these power supplies is contained in the 11302 Cover Tray which also provides the proper mounting facility and must be ordered as an accessory.

Audio designers will find these exceptional units and their associated companion pieces ideal for the development and construction of top quality audio input equipment.



1515 S. Manchester Ave., Anaheim, Calif.

New York, Los Angeles

SPECIFICATIONS

522B Power Supply:	117 volt, 60 cps, 80 watts
External Power Available:	6.3 v ac at 4.9 amperes; and 270 vdc at 135 ma with 0.2 v ripple, or 260 vdc at 40 ma with 0.001 v ripple, or 270 v at 70 ma and 250 v at 65 ma
Tubes:	2 — 6X4
Dimensions:	4¼" H, 2¼" W, 10" D
Color:	Cadmium plate
Weight:	6 lbs.
Accessories:	11302 Cover Tray
523B Power Supply:	117 volt, 60 cps, 20 watts
External Power Available:	12 vdc at 1,200 ma (12 vdc at 1,000 ma when 3 internal relays are operated)
Tubes:	Selenium rectifier
Dimensions:	4¼" H, 2¼" W, 10" D
Color:	Cadmium plate
Weight:	3½ lbs.
Accessories:	11302 Cover Tray

See Amplifier Accessories sheet for additional mounting facilities and accessories.

ARCHITECTS AND ENGINEERS SPECIFICATIONS

522B

The power supply shall be small in size measuring no larger than 4¼" H, 2¼" W, 10" D, and shall weigh in the order of 6 pounds. The plug-in contacts shall be gold plated to assure perfect contact. The power supply shall have a tube complement of two 6X4 tubes.

The power supply shall be capable of furnishing 6.3 vac at 4.9 amperes; and 270 vdc at 135 ma with 0.2 v ripple, or 260 vdc at 40 ma with 0.001 v ripple, or 270 v at 70 ma and 250 v at 65 ma. This unit shall meet the requirements of the broadcasting industry.

A power supply not of the plug-in type, or one which does not meet the specifications above of output and ripple voltage, shall not be acceptable under these specifications.

The power supply shall be Altec Lansing Model 522B.

523B

The power supply shall be one of special design and of heavy duty long life construction to furnish the voltages for relays and signal lights, and shall be of the finest quality of construction. The power supply shall measure 4¼" H, 2¼" W, 10" D, and shall weigh in the order of 3½ pounds. The chassis shall be cadmium plated for appearance and protection. A unit having a painted finish shall not be acceptable under these specifications.

The dc voltage shall be provided by a selenium rectifier of proper size and shall furnish the following voltages: 12 vdc at 1,200 ma (12 vdc at 1,000 ma when the three internal relays are operated). The power supply shall be of the plug-in type. It shall include three relays and three substitute load resistors.

Any power supply not of the plug-in type, or not meeting the above description shall not be acceptable under these specifications.

The power supply shall be Altec Lansing Model 523B.

1566A Preamplifier

1566A



- Compact
- Three-stage
- Low noise
- No installation soldering
- High fidelity quality
- Two outputs
- High or low impedance input
- Quality construction

The 1566A is a compact three-stage microphone preamplifier with self-contained power supply. As supplied, its input will accept high impedance microphones and its output will drive one or many high impedance amplifiers such as the Altec 1568, 1569 or 1570. The preamplifier may be used with low impedance microphones by the addition of the accessory Altec 4722 plug-in microphone transformer.

150 and 600 ohm output loads may be accommodated by the addition of the plug-in Altec 15095 line transformer. When this transformer is used, both line and direct output are available simultaneously.

This compact microphone preamplifier occupies only one unit of standard rack space (1 $\frac{3}{4}$ "'). The front panel contains a continuously variable gain control, pilot light, power switch and circuit fuse. All input and output connections are made to simple screw terminals on the rear of the chassis, doing away with the necessity for time-consuming soldering. A pre-wired three conductor power cord and connector is supplied, and an auxiliary AC convenience outlet controlled by the power switch is provided on the rear chassis.

The circuit consists of a two stage voltage amplifier, with an inter-stage volume control, followed by a cathode follower output. The power supply uses selenium rectifiers for both high voltage and heater supply circuits for long life, cool operation and hum-free performance. The quality exceeds all FCC requirements for FM and AM broadcasting and the 1566A will find wide application in commercial systems requiring only a small number of microphone inputs.



1515 S. Manchester Ave., Anaheim, Calif.

New York, Los Angeles

SPECIFICATIONS

Gain:	67 db max.
Power Output:	+ 10 dbm or 25 v (rms) open circuit
Frequency Response:	± 1 db 30-15,000 cps
Input Impedance:	100,000 ohms
Source Impedance:	30/50 and 120/200 ohms with 4722 plug-in microphone transformer
Load Impedance:	15,000 ohms to infinity, 150 and 600 ohms with 15095 plug-in line transformer.
Noise Level:	Equivalent input noise -122 dbm Output noise -81 dbm with gain control closed
Controls:	Gain and power
Power Supply:	117 volts, 60 cps, 5 watts
External Power Available:	117 volt ac receptacle on chassis
Tubes:	2 - 12AX7
Dimensions:	1 $\frac{3}{4}$ " H x 19" W x 7" D (rack mounting)
Color:	Dark green
Weight:	5 $\frac{1}{2}$ lbs.
Accessories:	4722 Plug-in microphone transformer 15095 Plug-in line transformer

ARCHITECTS AND ENGINEERS SPECIFICATIONS

The preamplifier(s) shall be of the rack mount type and shall occupy not more than 1 $\frac{3}{4}$ " of rack space. Each preamplifier shall be self powered and separate power supplies will not be acceptable. The gain of the preamplifier shall be at least 67 db, and the frequency response shall be ± 1 db 30 to 15,000 cps. The equivalent input noise shall be not greater than -122 dbm. The preamplifier shall be equipped with an interstage volume control. The input impedance shall be (choose one) 100,000 ohms (or) 30/50 and 120/200 ohms as provided by a plug-in transformer specified elsewhere. The load impedance shall be (choose one) at least 15,000 ohms (or) 150 and 600 ohms as provided by a plug-in line transformer specified elsewhere. The maximum power output shall be at least (choose one) 25 volts rms open circuit (or) + 10 dbm with the plug-in line transformer.

A standard three-blade AC convenience receptacle shall be provided on the chassis of the preamplifier. Power consumption of the preamplifier shall not exceed 5 watts.

The preamplifier shall be Altec Lansing Model 1566A.

1568A Power Amplifier

1568A



- High efficiency
- Easy service access
- Low installation costs
- Simple circuitry
- High and low impedance inputs
- 70V and 25V outputs
- Low cost per watt
- Built-in speaker protection
- Stable under all load conditions
- Underwriters approved
- Low power consumption
- Outstanding quality
- Inputs and outputs may be safely paralld

The 40 watt 1568A power amplifier is an important element in the Altec Lansing "1500 Series" of "Building Block" public address amplifiers, pre-amplifiers and accessories. It has been carefully engineered for simple, high-speed installation in order to reduce labor costs. For maximum reliability, the circuitry has been designed to withstand "hot switching" and other punishment which the amplifier may be given by non-technical operators.

This 40 watt amplifier is only 8 $\frac{3}{4}$ " in height and will mount in either the standard Altec 101F Relay Rack or the Altec 12066 wall and table cabinet. Outstanding features include continuously variable gain control, power switch, pilot light and fuse mounted on a hinged front panel where they are readily accessible. The complete circuitry of the amplifier and its controls is exposed for easy servicing when this panel is opened. All connections are made to the rear of the amplifier through simple barrier-type terminal blocks and a pre-wired three conductor power cord.

The input facility of the amplifier provides direct connection to the input potentiometer for unbalanced high and low impedance sources with a minimum of 0.9 volt signal strength. Independent input terminals connect to an octal socket which will accept the Altec 4665 or 15095 Matching Transformer for balanced low impedance lines up to a level of +8 dbm. These two inputs can be used simultaneously for greater facility.

The amplifier will accommodate output loads of 4, 8, 16 and 124 ohms: the corresponding drive voltages being 12.6, 18, and the popular 25 and 70 volts. Circuit design provides exceptional stability under varying conditions of line voltage, tube characteristics and long unloaded speaker lines of large capacitance. A low frequency cut-off in the amplifier gives protection for driver speakers. Four steps provide from 0 to 22 db of attenuation at 250 cycles.

The 1568A is ideal for all types of public address, paging, music distribution and sound reinforcement systems requiring moderate power handling capacity.



1515 S. Manchester Ave., Anaheim, Calif.
New York, Los Angeles

SPECIFICATIONS

Gain:	65 db
Input Sensitivity:	0.9 volts
Power Output:	40 watts at less than 2% thd 40-20,000 cps
Frequency Response:	± 1 db 5-30,000 cps, ± 4 db 1-100,000 cps
Input Impedance:	70,000 ohm potentiometer
Source Impedance:	30/50, 125/150, 250/300 and 500/600 ohms with 4665 or 15095 plug-in transformer
Load Impedance:	4 (12.6V), 8 (18V), 16 (25V), 124 (70V) ohms ungrounded
Output Impedance:	Less than 15% of nominal load impedance
Noise Level:	80 db below rated output
Controls:	Volume control, continuously variable composition
Power Supply:	117 volts, 60 cps, 125 watts
External Power Available:	117 volt AC receptacle on chassis
Tubes:	2-6CG7, 2-6CA7/EL34, 1-5U4GB
Dimensions:	8 $\frac{3}{4}$ " H, 19" W, 7 $\frac{3}{4}$ " D
Color:	Green
Weight:	22 lb.
Special Features:	For 1500 series applications. This amplifier has a two-stage Hi-Pass filter for protection of horn loaded drivers.

ACCESSORIES

4665 or 15095 Input Matching Transformer

See Amplifier Accessories sheets for relay racks, mounting cabinets, and other amplifier accessories.

ARCHITECTS AND ENGINEERS SPECIFICATIONS

The power amplifier shall be of the rack mounting type measuring not more than 8 $\frac{3}{4}$ " H, 19" W, and 7 $\frac{3}{4}$ " D. The amplifier shall include a continuously variable volume control of composition material, together with pilot light, fuse holder, and on-off switch. Any amplifier utilizing a common "radio type" volume control and not including these features shall not be acceptable under these specifications.

The power output shall be 40 watts with less than 2% total harmonic distortion over the frequency range of 40 to 20,000 cycles. The frequency response shall be ± 1 db 5 to 30,000 cycles, or ± 4 db 1 to 100,000 cycles. The noise level shall be 80 db below rated output. The overall gain of the amplifier shall be no less than 65 db. The output impedance shall be less than 15% of nominal load impedance. The load impedance shall be 4, 8, 16 (25V) and 124 (70V) ohms ungrounded. The input sensitivity shall be 0.9V rms for rated output. The input impedance shall be 70,000 ohm volume control, and the source impedance 30/50, 125/150, 250/300 and 500/600 ohms with 4665 or 15095 plug-in transformer. The amplifier shall operate from 117V 60 cycles and shall not draw more than 125 watts from the primary circuit. The tube complement shall consist of two 6CG7, two 6CA7/EL34, one 5U4GB. The unit shall be finished in green and shall weigh in the order of 22 pounds.

Any power amplifier which does not have a tertiary winding in the output transformer for the proper regulation of the feedback circuit shall not be deemed acceptable under these specifications.

The amplifier shall be Altec Lansing Model 1568A.

1569A Power Amplifier

1569A

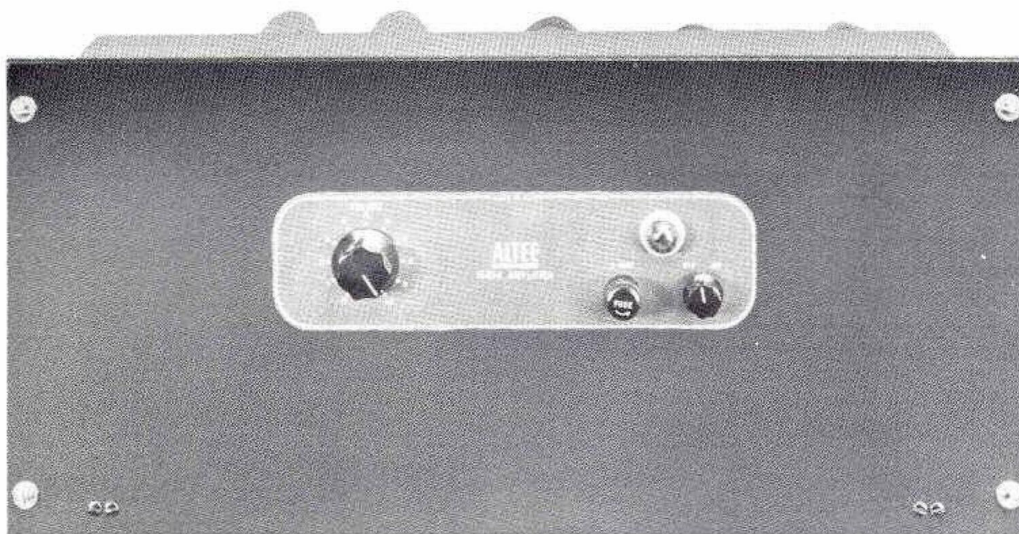

Underwriters approved

Low power consumption

Inputs and outputs may be safely paralleled

70V and 25V outputs

Low cost per watt

High and low impedance inputs

Built-in speaker protection

Low installation costs

Full 80 watt output

Simplified installation

The 1569A power amplifier will provide 80 watts of power with great stability under conditions of varying line voltage, changing tube characteristics and long unloaded speaker lines of high capacitance. This amplifier is part of the "Building Block 1500 Series" which provide fully integrated public address facilities.

The straight-forward circuitry of the amplifier provides unusual reliability. It is possible for as many as three power tubes and one rectifier tube to fail without removing the amplifier from service. It will withstand "hot switching" and other punishment which the amplifier may be given by non-technical operators.

Installation costs have been materially reduced since all input and output connections are made to simple barrier-type terminal blocks on the rear of the chassis and the amplifier contains a pre-wired three conductor power cord. For reduced system cost, the amplifier contains a low frequency cut-off which will provide from 0 to 22 db of attenuation at 250 cycles for the protection of driver type loudspeakers.

Two inputs are provided, one for unbalanced low or high impedance lines with a minimum of 0.9 volt signal strength, and one which connects to the accessory Altec 15095 or 4665 plug-in line transformer for isolation from balanced lines of 150 or 600 ohms. These two inputs can be used simultaneously for greater facility.

The amplifier will accommodate output loads of 4, 8, 16 and 62 ohms: the corresponding output voltages being 18, 25, 36 and 72 volts. The great stability of the circuit makes it possible for two of these amplifiers to be paralleled both at input and output.

The 1569A amplifier can be mounted in either the standard Altec 101F Relay Rack or the Altec 12066 wall and table cabinet. When used with associated components of sufficient quality to realize its full potentialities, the 1569A is ideal for higher powered public address, paging, music distribution and sound reinforcement systems.

ALTEC
LANSING CORPORATION

1515 S. Manchester Ave., Anaheim, Calif.

New York, Los Angeles

SPECIFICATIONS

Gain:	68 db
Input Sensitivity:	0.9 volts
Power Output:	80 watts at less than 2% thd 60-20,000 cps 80 watts at less than 5% thd 40-20,000 cps
Frequency Response:	± 1 db 5-30,000 cps, ± 5 db 1-100,000 cps
Input Impedance:	70,000 ohm potentiometer
Source Impedance:	125/150 and 500/600 ohms with 15095 or 4665 plug-in transformer
Load Impedance:	4 (18 V), 8 (25 V), 16 (36 V), 62 (70 V) ohms ungrounded
Output Impedance:	Less than 15% of nominal load impedance
Noise Level:	80 db below rated output
Controls:	Volume control, continuously variable, composition
Power Supply:	117 volts, 60 cps, 240 watts
External Power Available:	117 volt AC receptacle on chassis
Tubes:	Two 6CG7, four 6CA7/EL34, two 5U4GB
Dimensions:	8 $\frac{3}{4}$ " H, 19" W, 8" D
Color:	Green
Weight:	27.5 lbs.
Special Features:	For 1500 series applications. This amplifier has a two-stage built-in Hi-Pass filter.

ACCESSORIES

15095 or 4665 Plug-in Line Transformer.

See Amplifier Accessories sheet for relay racks, mounting cabinets, and other amplifier accessories.

ARCHITECTS AND ENGINEERS SPECIFICATIONS

The power amplifier shall be of the rack mounting type measuring not more than 8 $\frac{3}{4}$ " H, 19" W, and 9" D. The amplifier shall include a continuously variable volume control of the composition type on the front panel, together with pilot light, fuse holder, and on-off switch. The front mat shall be hinged for easy access to the front portion of the amplifier for maintenance. Any amplifier utilizing a common "radio type" volume control and not including these features shall not be acceptable under these specifications.

The power output shall be 80 watts with less than 2% total harmonic distortion over the frequency range of 60 to 20,000 cycles, and 80 watts with less than 5% total harmonic distortion over the frequency range of 40 to 20,000 cycles. The frequency response shall be ± 1 db 5 to 30,000 cycles, or ± 5 db 1 to 100,000 cycles. The noise level shall be 80 db below rated output. The overall gain of the amplifier shall be no less than 68 db. The output impedance shall be less than 15% of nominal load impedance. The load impedance shall be 4 (18 v), 8 (25 v), 16 (36 v), 62 (70 v) ohms ungrounded. The input sensitivity shall be .9 volts rms for rated output. The input impedance shall be 70,000 ohm volume control, and the source impedance 125/150 and 500/600 ohms with 15095 or 4665 plug-in transformer. The amplifier shall operate from 117 v 60 cycles and shall not draw more than 240 watts from the primary circuit. The tube complement shall consist of two 6CG7, four 6CA7/EL34, two 5U4GB. The unit shall be finished in green and shall weigh in the order of 27.5 pounds.

Negative feedback must be derived from a tertiary winding in the output transformer. Amplifiers employing grounded outputs or other means of feedback will not be acceptable.

The amplifier shall be Altec Lansing Model 1569A.

1570A Amplifier

1570A



- 165 watts
- Low power consumption
- Compact
- Wide frequency range
- Low distortion
- Economical installation
- Low cost per watt
- Oil filled condenser
- Center tapped transformer for simplexing speech lines
- Conservative tube operation

The Altec 1570A Power Amplifier, a high powered, high efficiency public address amplifier, is an important part of the Altec 1500 series of amplification and control equipment. It is designed for quality performance, high reliability and economy of operation. With a nominal rating of 165 watts, it delivers more clear, wide-range, undistorted power per dollar invested than any other amplifier. Yet, for this exceedingly high continuous output, the 1570A draws only 350 watts from the power line; a significant factor in reducing operational costs, especially in continuous duty installations.

Vacuum tubes, the foremost item of replacement in any public address system, have been reduced in number of types through the application of the latest circuit techniques and all of the ten tubes used in the amplifier are operated well within their CCS (continuous commercial service) ratings. This carefully rendered circuit design reduces tube replacement to the absolute minimum and keeps replacement stocks small both in number and dollar investment.

An additional feature for economy of installation is the use of externally mounted barrier terminal strips for both input and output connections and the pre-wired three conductor power cord. These facilities, which are rarely found on an amplifier of this power capacity, permit all connections to be made to the amplifier without the use of a soldering iron or the necessity for removing the unit's protective cover.

The 1570A is designed for simple shelf or cabinet mounting, or it may be easily rack or wall mounted by attaching the accessory Altec 12442 Assembly. The chassis and cover design provide adequate ventilation in any of these mountings and the general compactness of the amplifier affords maximum utilization of valuable operating space.

The 1570A, with its many engineering and operational features, is the obvious choice for economy, reliability and quality in public address, sound distribution and music systems requiring from 100 to 175 watts of power.



1515 S. Manchester Ave., Anaheim, Calif.
New York, Los Angeles

SPECIFICATIONS

Gain:	72 db
Input Sensitivity:	1.0 volt rms for rated output
Power Output:	165 watts at less than 3% thd, 70-20,000 cps
Frequency Response:	± 1.0 db, 10-50,000 cps
Input Impedance:	100,000 ohm potentiometer
Source Impedance:	125/150 and 500/600 ohms with 15095 Plug-in Transformer
Load Impedance:	8, 16, 32 (70 v line) ohms
Output Impedance:	Less than 10% of nominal load impedance
Noise Level:	Output noise -25 dbm: 77 db below rated output
Controls:	Volume control, continuously variable, composition
Power Supply:	117/125 volts, 60 cps, 350 watts
External Power Available:	117 vac receptacle on chassis
Tubes:	One 12AX7/12AD7, one 6SN7GTB, two 6W6GT, two 811-A, four 5U4GB
Dimensions:	9 $\frac{3}{8}$ " H, 17" W, 13 $\frac{3}{4}$ " D
Color:	Green
Weight:	58 lbs.
Accessories:	15095 Plug-in Transformer 12442 Rack Mounting Assembly

ACCESSORIES

See "Power Amplifier Accessories" sheets for plug-in transformer, rack mounting facilities, and other amplifier accessories.

ARCHITECTS AND ENGINEERS SPECIFICATIONS

The amplifier shall be one designed for either shelf or rack mounting measuring not less than 9 $\frac{3}{8}$ " H, 17" W, and 13 $\frac{3}{4}$ " D. The rack mounting facility shall measure no more than 19" W and shall require not more than 10 $\frac{1}{2}$ " of rack space. This amplifier shall have an input sensitivity of 1 v rms for rated output, and there shall be a continuously variable volume control, a pilot light, and on-off switch on the front panel assembly.

The power output shall be 165 watts with less than 3% total harmonic distortion over the frequency range of 70 to 20,000 cycles. The frequency response of the amplifier shall be ± 1 db at 10 to 50,000 cycles. Output noise shall be no greater than 25 dbm: 77 db below rated output. The overall gain of this amplifier shall be no less than 72 db.

The output impedance shall be less than 10% of nominal load impedance. The load impedance shall be 8, 16, and 32 (70 v line) ohms.

The input impedance shall be 100,000 ohm potentiometer with source impedances of 125/150 and 500/600 ohms with plug-in transformer.

The power amplifier shall operate from 117/125 v, 60 cycles, and shall not draw more than 350 watts from the primary circuit. There shall be incorporated on the back edge of the amplifier chassis a 117 vac 60 cycle receptacle. The tube complement shall be one 12AX7/12AD7, one 6SN7GTB, two 6W6GT, two 811-A, and four 5U4GB. The unit shall be finished in green and shall weigh in the order of 58 lbs.

Any power amplifier which does not have a tertiary winding on the output transformer to permit isolation of the load circuit from ground shall not be deemed acceptable under these specifications.

The amplifier shall be Altec Lansing Model 1570A.

Amplifier Accessories



1551A



1555A



1552A

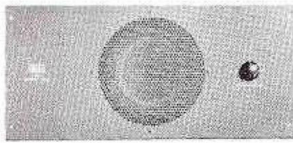

1553A



1554A



12894



12895



11338

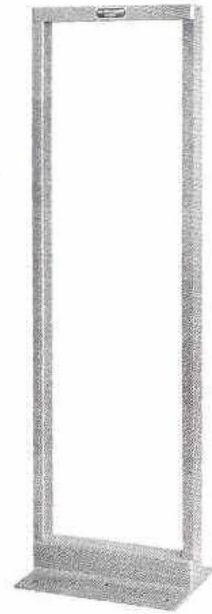

101F

1551A JACK PANEL

Mounts in 1 $\frac{3}{4}$ " of standard relay rack space. Contains 12 pairs of jacks with designation strip. Jacks are of 3-terminal normal-through type, the circuit being broken when the plug is inserted.

1552A METER PANEL

Contains a VU meter, range switch and pads, and terminal strip on a 3 $\frac{1}{2}$ " relay rack panel. The range switch includes an off position and provides ranges to indicate program levels of + 5, + 10 and + 15 VU on a 600 ohm circuit. Provision is made for mounting an additional fixed pad for circuits of other impedance or level such as a 70 volt line. Finished in standard Altec green.

1553A MONITOR PANEL

Occupies 8 $\frac{3}{4}$ " of rack space and contains a 401A loudspeaker, a 15064 transformer and an adjustable L pad volume control. Altec green.

1554A POWER DISTRIBUTION PANEL

For master power control this panel has six outlets on the rear side controlled by a 20 ampere switch with pilot light mounted on the face panel. Two additional outlets, not controlled by the power switch are on the face of the panel. Occupies 5 $\frac{1}{4}$ " of rack space. All outlets are of the 3-pin type. Altec green.

1555A SWITCHING PANEL

This 3 $\frac{1}{2}$ " relay rack panel contains 12 independent 2-circuit, 3-position level switches with designation strips to identify both the individual switches and the function of their different positions. Altec green with black switch levers.

4722 INPUT MATCHING TRANSFORMER

Provides low impedance microphone inputs for all Altec amplifiers equipped for plug-in microphone input transformers. Has 60 db electro-magnetic shielding; freq. response ± 1 db 30-15,000 cps; impedance of 30/50, 120/200 (with C.T.), & 40,000/65,000 ohms. Plug-in socket mounting.

15095 LINE TRANSFORMER

Miniature plug-in line transformer to provide balanced output for Altec amplifiers designed to accept this accessory. Has 30 db electromagnetic shielding; ± 1 db 30-20,000 cps freq. response; 125/150, 500/600 (with C.T.), and 15,000 ohm impedances; max. operating level of + 15 dbm above 30 cps, + 20 dbm above 40 cps.

12066 CABINET

Heavy wall or desk cabinet provides 17 $\frac{1}{2}$ " of standard rack space. Top door provides access to rear of equipment. 19 $\frac{1}{4}$ " h, 22" w, 15" d. Gray finish with chrome trim.



1515 S. Manchester Ave., Anaheim, Calif.

New York, Los Angeles

11338 MOUNTING ASSEMBLY

Rack mounting facility for 428 and 429 plug-in amplifiers and 522 and 523 plug-in power supplies for custom installations. Will hold nine 11301 Trays for 428 or six 11302 Trays or a combination. Trays mount permanently and wiring gutters and terminals are provided. The assembly does not include trays or plugs which should be ordered separately as required. Dimensions—7" h, 19" w, 12³/₈" d. Available mounting space—16". Gray finish.

12156 ASSEMBLY

Rugged wall mounting facility for 260 Amplifier. Has wiring gutters for neat installation. 17³/₄" h, 20" w, 12⁵/₈" d. Altec green finish.

12210 ASSEMBLY

Rack mounting assembly for 342 Amplifier. Occupies 8³/₄" of rack space. Finished in standard Altec green.

12442 ASSEMBLY

Rack mounting facility for Altec 1570 Power Amplifier. Controls and escutcheon appear through front mat for neat appearance. Occupies 10¹/₂" of rack space. Finished in standard Altec green.

12495 CABINET

Neat table cabinet for the 426, 438 and 429 Compressor Amplifiers. 4" h, 20" w, 7¹/₂" d. Altec green.

12693 ASSEMBLY

Rack mounting facility for 305 & 306 radio tuners, 440 preamplifier and 344 & 346 amplifiers. Front mat neatly frames control panel of unit. Occupies 5¹/₄" of rack space. Altec green.

12894 CABINET

Sturdy modern table cabinet with 8³/₄" of rack space on both sides. Equipment may be mounted from either side or, with shallow equipment, both sides may be used. Well ventilated with complete access to equipment from top and rear. 12" h, 21³/₄" w, 15¹/₄" d. Standard Altec green.

12895 CABINET

Same features as 12894 cabinet but has 17¹/₂" of rack space front and rear.

101F RACK

An exceptionally well constructed relay rack, well guttered to contain all wiring. Has wide base for improved stability. Provides 36 units (63") of rack space. Underwriters Approved. 68⁷/₈" h, 20¹/₄" w, 15" d. Gray finish.

BLANK PANELS

Plain metal panels finishes in standard Altec green to provide a finished appearance to relay racks not entirely filled with equipment. All panels are drilled for standard relay rack mounting and are 19" wide.

10399 Panel — 1³/₄" h.

10281 Panel — 3¹/₂" h.

10282 Panel — 5¹/₄" h.

10283 Panel — 7" h.

10284 Panel — 8³/₄" h.

10440 Panel — 10¹/₂" h.

10441 Panel — 12¹/₄" h.

A-7 Loudspeaker System

A-7

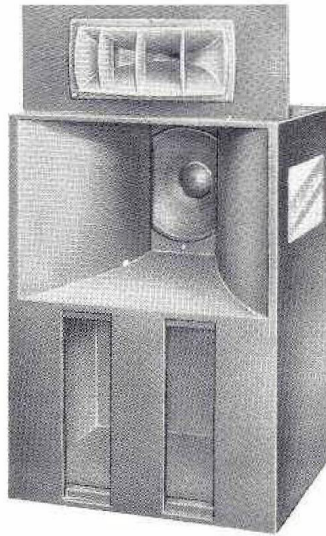

35-22,000 cycle range

Acoustic engineered

Theatre quality

Bass reflex horn

Sectoral high frequency horn

Full two-way system

Adjustable dividing network

The A-7 Speaker System is the smallest of the famous Altec "Voice of the Theatre" systems. Compactness and large power capacity permit the use of this system in small to medium sized auditoriums, night clubs, meeting halls, and similar type rooms. The speaker system employs the 802D high frequency driver unit connected to a die cast exponential horn for the reproduction of tones above 800 cycles.

The low frequencies are reproduced by the 803A low frequency speaker mounted on a short exponential horn to provide good coupling and high efficiency. This design provides wide range frequency response without the phase distortion inherent in three-way systems or folded horn types. The low frequency horn is of heavy construction, fully braced, and of true exponential expansion.

The complete A-7 system has a smooth effective frequency range from 35 to 22,000 cycles and is fully capable of reproducing all of the sounds and dynamic range within the normal limits of human hearing. The use of this high quality system assures complete accuracy and naturalness for music and voice reproduction.



1515 S. Manchester Ave., Anaheim, Calif.

New York, Los Angeles

SPECIFICATIONS

Power Rating:	30 watts
Impedance:	16 ohms
Horizontal Distribution:	90°
Vertical Distribution:	40°
Frequency Response:	35-22,000 cps
Crossover:	800 cps, 6 db adjustable h.f. attenuation
Dimensions:	54" H 30" W 24" D
Finish:	Gray
Weight:	180 lbs.

ARCHITECTS AND ENGINEERS SPECIFICATIONS

The speaker system shall be of the two-way theatre type. The frequency response of the system shall be uniform to 22,000 cycles, and the efficiency shall be at least 57.0 db (EIA). The high frequency section shall consist of a compression type driver mounted on a straight exponential horn of die cast aluminum. Horns employing bends or of non-metallic construction will not be acceptable under this specification. The horn shall provide a uniform coverage over a horizontal angle of 90° and a vertical angle of 40°.

The low frequency section shall employ a single 15" speaker mounted on a short exponential horn to provide proper phasing with the high frequency horn. Systems employing folded horns will not be acceptable under this specification because of inherent phase shift.

The crossover between the two sections shall be at 800 cycles with a full section network. The speaker system shall have a continuous power rating of 30 watts and shall not exceed 54" high, 30" wide, or 24" deep. Weight shall not exceed 180 pounds. The speaker system shall be Altec Lansing Model A-7.

50A "Bi-Acoustic" Horn System

50A

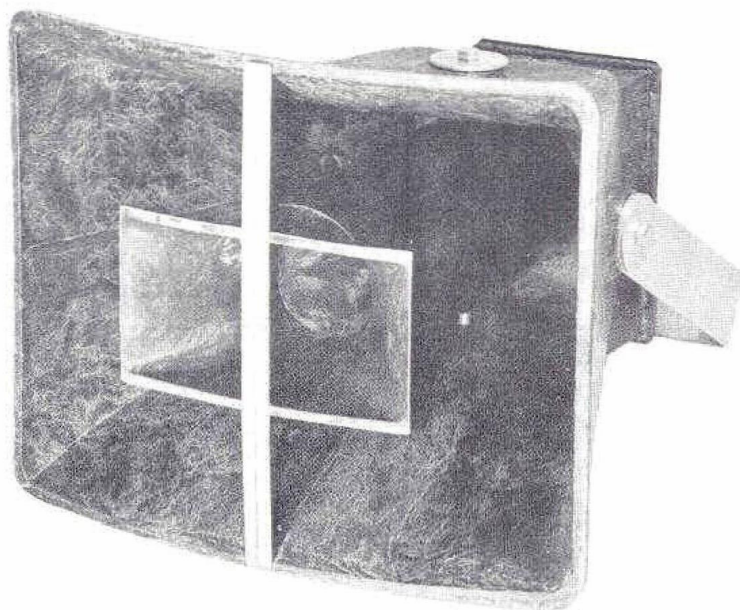

Newest concept in PA speaker design

Two-way system in a single frame

Controlled drive from front of diaphragm

Exclusive "Bi-Acoustic" radiator

New acoustical crossover

Controlled wide angle distribution

Universal mounting facility for ease of installation

Smoothest, widest frequency response of any

all-weather speaker

Completely moisture and dust proof

Moderately priced

Highly efficient

Non-resonating rigid Fiberglas construction

The 50A "Bi-Acoustic" Horn System is the latest addition to the ALTEC line of fine public address equipment. The "Bi-Acoustic" is a truly *all-new* wide range speaker of exceptional quality for indoor or outdoor use in any public address or announcing application. Wide frequency range and outstanding bass response make the 50A suitable for reproduction of background music in large halls and auditoriums. In any outdoor application its completely dust, water, and weather proofed construction assures permanent reliability even under the most critical conditions.

The "Bi-Acoustic" principle provides the single high efficiency transducer with two sound paths, operating in phase from the *front* side of the diaphragm, for the propagation of low and high frequencies. This principle provides complete and positive sealing for the voice coil and magnetic gap against moisture and dust. An exclusive acoustic filter directs the lower frequencies through a long reflex air column; tones above 1000 cycles are directed through a straight exponential horn. This unique two-way use of a single driving element combines the economy of a single speaker with the intelligibility characteristics of much more complicated and expensive two-way speaker systems. The two exponential horns provide positive control of distribution at all frequencies—a control which cannot be obtained by diffraction horns which cause diffusion of sound waves in an uncontrolled manner.

The driving element consists of an Alnico V magnetic structure, an aluminum voice coil, and a rigid phenolic diaphragm. The voice coil-diaphragm assembly can be easily replaced in the field without special tools or skills. Space is also provided in the rear of the horn assembly for the ALTEC 15075 Matching Transformer for 70 volt line operation.

The 50A is made of heavy, double re-enforced Fiberglas which eliminates internal resonance common to less sturdy public address speakers. It is equipped with a universal mounting bale which permits easy mounting in any direction and to any structure or surface. For rapid wiring, the cover plate contains two weather-proof knock-outs which receive either conduit or cable.



1515 S. Manchester Ave., Anaheim, Calif.
New York, Beverly Hills, Los Angeles

SPECIFICATIONS

Power:	30 watts
Frequency Response:	175-12,000 cps
Impedance:	16 ohms
Average Sound Level:	(Warble frequency 500-2500 cycles 4' from mouth of horn) 106 db ref. .0002 dynes/cm ² for 1 volt-ampere input
Horizontal Distribution:	90°
Vertical Distribution:	50°
Acoustical Crossover:	1000 cycles
Mounting:	Universal mounting bale—horizontal or vertical
Finish:	High-impact green Fiberglas
Dimensions:	(Less mounting bale) H—12½"; W—15½"; D—17¼"
Weight:	15½ lbs.

ACCESSORIES

15075 Matching Transformer permits the use of a 70 volt line. See "Transformers" for details and specifications.

ARCHITECTS AND ENGINEERS SPECIFICATIONS

The loudspeaker horn system shall be Altec Lansing Model 50A. It shall be of the two-way coaxial type employing the "Bi-Acoustic" principle of sound distribution. It shall employ a phenolic diaphragm and a voice coil of round aluminum wire. This assembly as well as the entire driver unit shall be field replaceable without special tools or skills. All acoustical energy shall emanate from the front of the diaphragm, the back side to provide a seal for the voice coil and magnetic gap. Proper loading shall be achieved by means of a 1000 cycle acoustical crossover. The low frequency horn shall be folded and not less than 36" in total length. The high frequency horn shall be straight and at least 14" long. High and low frequency horns of shorter length shall not be acceptable under this specification. With 1 watt input, the system shall produce a sound pressure level of at least 106 db over the warble band of 500-2500 cps at a distance of 4 feet. Single frequency measurements will not be acceptable for qualification under this specification. The frequency response shall be uniform from 175 to 12,000 cps and the speaker shall be capable of handling a continuous power level of 30 watts.

Both the high and low frequency sections of this horn shall be of sufficient size to operate as true projectors. Horns obtaining distribution by the diffraction method will not be acceptable. The loudspeaker shall have uniform distribution over a 90° horizontal and 50° vertical field. The horn assembly shall be of heavy, re-enforced Fiberglas at least 3/16" thick, shall be completely dust, moisture, and weather proof, and shall provide sealing to the driver unit and matching transformer specified elsewhere.

288B Driver Loudspeaker

288B



Theatre quality
Smooth response
Field replaceable diaphragm
Large ribbon voice coil
40 watt power capacity
High efficiency
Perfect for two-way systems

The Altec 288B Driver Speaker has been designed for use in high level music, speech reinforcement and paging systems of the highest quality. It may be used with any of the Altec multicellular horns and will provide a smooth response from 500 to 12,000 cycles. This wide range, when used in conjunction with Altec low frequency speakers, will provide full high fidelity reproduction for the largest theatre or auditorium. These same drivers are used in the famous Altec "Voice of the Theatre" speaker systems found in more than 12,000 of the world's finest motion picture theatres.

The efficiency of the 288B is higher than that of any other high quality speaker available for use in public address systems.

Like all Altec public address driver speakers, the diaphragm, voice coil assembly of the 288B can be replaced in the field by untrained personnel without the use of special tools. The high efficiency and smooth reproduction characteristics to the upper limits of human hearing, make the 288B the obvious choice for all large sound systems where quality and full-range, faithful reproduction are a requisite.



1515 S. Manchester Ave., Anaheim, Calif.
New York, Los Angeles

SPECIFICATIONS

Power:	40 watts (with 500C network)
Frequency Response:	500-12,000 cps
Impedance:	24 ohms
Average Sound Level:	(Warble frequency 500-2,500 cps 4' from mouth 30" trumpet) 115.2 db ref. .0002 dynes/cm ² for 1 volt-ampere input
Protection:	Should be used with 500C in all cases for low frequency protection
Voice Coil Diameter:	2.8"
Dimensions:	Diameter 6½" Height 4⅞"
Finish:	Gray
Weight:	20 lbs.

ARCHITECTS AND ENGINEERS SPECIFICATIONS

The loudspeaker driver unit shall employ an aluminum diaphragm and a voice coil of edge wound aluminum ribbon. The voice coil diameter shall be at least 2.8 inches and the voice coil gap shall have a flux density of at least 18,000 gauss. The entire diaphragm voice coil assembly shall be field replaceable without special tools or skills.

This shall be interpreted to mean that the speaker shall incorporate self-centering dowels or other means to insure proper spacing. With 1 watt input, the speaker shall produce a sound pressure level of at least 115.2 db at a distance of four feet with a warble band of 500 to 2,500 cycles. Single frequency measurements will not be acceptable under this specification. The frequency response shall be uniform over the range 500 to 12,000 cycles and it shall be capable of handling a continuous power level of 40 watts above 500 cycles.

The driver loudspeaker shall be Altec Lansing Model 288B.

290C Driver Loudspeaker

290C



- 100 watt capacity
- High efficiency
- Field replaceable diaphragm
- Reduces system cost
- High intelligibility
- Weatherproof transformer housing
- Can be used in multiples

The Altec 290C Driver Loudspeaker is a high quality permanent magnet unit of exceptionally high power handling capacity and efficiency. It is designed for use with any of the Altec Lansing multicellular horns. The 290C finds wide application for public address speech reinforcement in large outdoor systems such as ball parks, race tracks, stadiums, etc.; indoors for sportscasting and in large industrial and commercial areas. As many as four of these 290C speakers may be mounted on a single horn to achieve continuous sound levels as high as 80 db one-half mile distant from the horn.

The moving element of the drive consists of a sturdy, weather-resistant phenolic diaphragm and a copper ribbon voice coil using an aluminum coil form for maximum heat dissipation at high power.

The entire voice coil, diaphragm assembly can be replaced in the field by un-trained personnel without any special tools. The weather-proof cover on the rear of the speaker is drilled and tapped to house a matching transformer for 70 v line operation.

Experience has proven that the use of the 290C in large systems rather than a number of speakers of less capacity not only results in higher quality and intelligibility but affords a reduction in overall system cost and upkeep.



1515 S. Manchester Ave., Anaheim, Calif.

New York, Los Angeles

SPECIFICATIONS

Power:	100 watts (above 300 cps)
Frequency Response:	300-8,000 cps
Impedance:	4 ohms
Average Sound Level:	(Warble frequency 500-2,500 cps 4' from mouth of 30" trumpet) 111.5 db. ref. .0002 dynes/cm ² for 1 volt-ampere input
Protection:	Should be used with 500D in all cases for low frequency protection
Outdoor Use:	Weather proofed construction
Voice Coil Diameter:	2.8"
Dimensions:	Diameter 5 ⁷ / ₈ " Height 7"
Finish:	Gray
Weight:	19 lbs.

ARCHITECTS AND ENGINEERS SPECIFICATIONS

The driver loudspeaker shall employ a phenolic diaphragm and a voice coil of edge wound copper ribbon. The voice coil diameter shall be at least 2.8" in diameter and the voice coil gap shall have a flux density of at least 18,800 gauss. The entire diaphragm voice coil assembly shall be field replaceable, without special tools or skills. This shall be interpreted to mean that the speaker shall incorporate self-centering dowels or other means to insure proper spacing. With 1 watt input, the speaker shall produce a sound pressure level of at least 111.5 db at a distance of four feet with a warble band of 500 to 2,500 cycles. Single frequency measurements will not be acceptable under this specification. The frequency response shall be uniform over the range 300 to 8,000 cycles and it shall be capable of handling a continuous power level of 100 watts above 300 cycles. Provision shall be incorporated to permit mounting a 70 volt matching transformer on the speaker and the entire assembly shall be enclosed in a weatherproofed housing. This matching transformer shall be supplied with the driver loudspeaker. The speaker shall be used in conjunction with 500 cycle network for low frequency protection.

The driver loudspeaker shall be Altec Lansing Model 290C.

401A Loudspeaker

401A

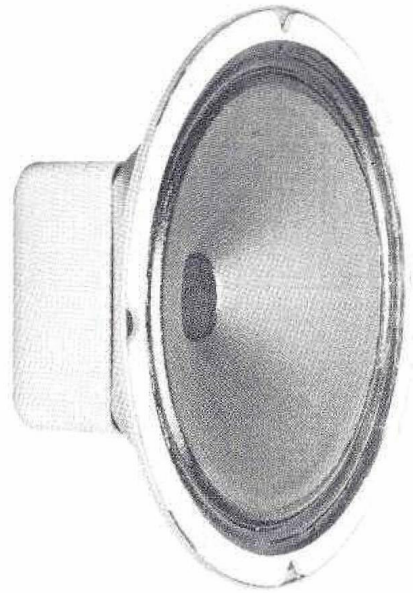

Compact design

High efficiency

High power capacity

Wide frequency range

Dust protected

Wide distribution angle

Large Alnico V magnet

Screw terminals

The Altec 401A Loudspeaker has been designed specifically for use in low level music distribution and paging systems. Its compact design and shallow depth greatly simplify installation problems.

The high efficiency of the magnetic structure and wide distribution angle reduce the number of speakers and amplifier power needed for good coverage. Additional features of the design are the sealed, dust protected magnetic structure, the pre-drilled mounting holes for 70 v distribution transformers, high power capacity and unusually wide frequency range. With these many features which are not found in any other speaker of this type the 401A has proven superior in all low level music distribution systems for quality, economy and reliability.



1515 S. Manchester Ave., Anaheim, Calif.

New York, Los Angeles

SPECIFICATIONS

Power:	14 watts
Frequency Response:	60-10,000 cps
Impedance:	8 ohms
Voice Coil Diameter:	1"
Diameter:	8½"
Magnet Weight:	.45 lb.
Mounting Hole Diameter:	7⅝"
Depth:	3⅝"
Weight:	2 lbs. 13 oz.

ARCHITECTS AND ENGINEERS SPECIFICATIONS

The loudspeaker shall be 8" in diameter, and shall have a minimum sensitivity of 50 db (EIA) measured on axis. The speaker shall have a continuous power rating of at least 14 watts. The voice coil shall operate in a magnetic field of at least 7,000 gauss derived from an Alnico V magnet of at least .45 pound. The frequency response shall be uniform over the range from 60 to 10,000 cycles and shall be free of peaks. The speaker shall have a broad angle of coverage to 10,000 cycles. Free air resonance shall not exceed 80 cycles. The speaker shall be sealed against dirt and magnetic dust.

This shall include a dust cover over the magnetic structure. Total depth, including dust cover, shall not exceed 3⅝".

The speaker shall be Altec Lansing Model 401A.

408A, 412B, 415A Loudspeakers

408A
412B
415A



408A



412B



415A

Exclusive Biflex principle

High efficiency

Wide frequency range

Smooth response

Alnico V magnet

High fidelity quality

Aluminum voice coil

Moderate price

Sealed against dust and dirt

This group of Altec loudspeakers feature the newly perfected Biflex principle of multiple concentric compliances (patent applied for). This development provides the entire area of the speaker cone for the propagation of low frequencies and permits the smaller central cone area to operate independently for the more efficient reproduction of higher tones. Below 1000 cps the stiffness of the mid-cone compliance is such that it couples the inner and outer sections into a single moving element. Above 1000 cps the balanced mass of the outer section prevents the transmission of sounds beyond the mid-compliance and the cone uncouples at this point permitting the inner section to operate independently. This Biflex principle results in a series of speakers having a smooth efficient frequency range far greater than that of any other type of single voice coil speaker, and exceeding that of many two or three-way units.

All of these speakers use Alnico V magnets and edge-wound aluminum voice coils for high efficiency, and have deep magnetic gaps to maintain good cone control for low distortion at high power levels.

In price, frequency range, efficiency and distribution pattern the Altec Biflex speakers are markedly superior to any other speakers for wide range use in small public address and music distribution systems, high fidelity installations, in multiple speaker background music installations and as the bass component for small two-way speaker systems. Because of their outstanding quality, the frequency range is guaranteed when the units are mounted in proper enclosures.

Altec Biflex speakers are available in the following sizes and frequency ranges: 408A, 8", 60-16,000 cps; 412B, 12", 40-15,000 cps; 415A, 15", 30-14,000 cps.

("Biflex" is a registered trademark of Altec Lansing Corporation.)



1515 S. Manchester Ave., Anaheim, Calif.
New York, Los Angeles

SPECIFICATIONS

408A

Power:	15 watts
Frequency Response:	60 to 16,000 cycles
Impedance:	8 ohms
Voice Coil Diameter:	1 $\frac{3}{4}$ "
Diameter:	8 $\frac{1}{4}$ "
Magnet Weight:	.67 lb.
Mounting Hole Diameter:	6 $\frac{7}{8}$ "
Depth:	3 $\frac{7}{16}$ "
Weight:	6 lbs.

412B

Power:	20 watts
Frequency Response:	40-15,000 cps
Impedance:	8 ohms
Voice Coil Diameter:	3"
Diameter:	12 $\frac{1}{4}$ "
Magnet Weight:	1.8 lbs.
Mounting Hole Diameter:	10 $\frac{1}{4}$ "
Depth:	5 $\frac{5}{8}$ "
Weight:	15 lbs.

415A

Power:	25 watts
Frequency Response:	30-14,000 cps
Impedance:	8 ohms
Voice Coil Diameter:	3"
Diameter:	15 $\frac{3}{16}$ "
Magnet Weight:	2.4 lbs.
Mounting Hole Diameter:	13 $\frac{1}{4}$ lbs.
Depth:	7"
Weight:	25 lbs.

ARCHITECTS AND ENGINEERS SPECIFICATIONS

408A

The loudspeaker shall be 8" in diameter, and shall have a minimum sensitivity of 52 db (EIA) measured on axis. The speaker shall have a continuous power rating of at least 15 watts. The voice coil shall be approximately 1 $\frac{3}{4}$ " in diameter. Voice coils of smaller diameter will not be acceptable under this specification. The voice coil shall operate in a magnetic field of at least 10,000 gauss derived from an Alnico V magnet of at least .67 pounds. To maintain high uniformity of response, the speaker shall employ a second compliance area in the cone and shall be treated with a permanent damping material. Free air resonance shall not exceed 70 cycles. The speaker shall be sealed against dirt and magnetic dust. It shall include a dust cover over the magnetic structure.

The speaker shall be Altec Lansing Model 408A.

412B

The loudspeaker shall be 12" in diameter, and shall have a minimum efficiency of 53 db (EIA) measured on axis. The speaker shall have a continuous power rating of at least 20 watts. The voice coil shall be approximately 3" in diameter and shall be of edge wound aluminum ribbon. Voice coils of smaller diameter or of round wire will not be acceptable under this specification. The voice coil shall operate in a magnetic field of at least 11,400 gauss derived from an Alnico V magnet of at least 1.8 pounds. The frequency response shall be guaranteed by the manufacturer to be uniform over the range of 40 to 15,000 cycles and shall be free of peaks when mounted in a suitable enclosure. It shall have a wide angle of distribution at all frequencies. This wide distribution and uniform response shall be guaranteed by the use of a second compliance area in the cone treated with a permanent damping material. Free air resonance shall not exceed 50 cycles. The speaker shall be sealed against dirt and magnetic dust. It shall include a dust cover over the magnetic structure.

The speaker shall be Altec Lansing Model 412B.

415A

The loudspeaker shall be 15" in diameter, and shall have a minimum efficiency of 54 db (EIA) measured on axis. It shall have a continuous power rating of at least 25 watts. The voice coil shall be approximately 3" in diameter and shall be of edge wound aluminum ribbon. Voice coils of small diameter or of round wire will not be acceptable under this specification. The voice coil shall operate in a magnetic field of at least 13,500 gauss derived from an Alnico V magnet of at least 2.4 pounds. The frequency response, when mounted in the proper enclosure, shall be guaranteed by the manufacturer to be uniform over the range of 30 to 14,000 cycles and shall be free of peaks. It shall have a wide angle of distribution at all frequencies. The wide distribution and uniform response shall be guaranteed by the use of a second area of compliance in the cone treated by a permanent damping material. Free air response shall not exceed 45 cycles. The speaker shall be sealed against dirt and magnetic dust. It shall include a dust cover over the magnetic structure.

The speaker shall be Altec Lansing Model 415A.

Sectoral Horns

511A
811B

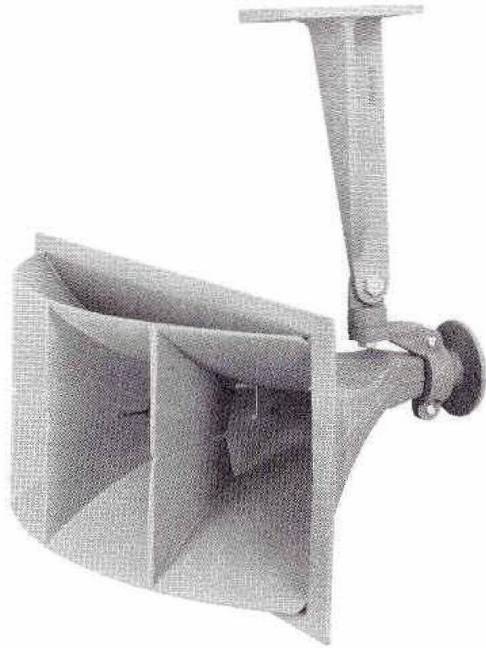

511A Horn
with mounting bracket

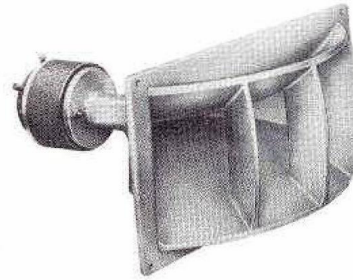

811B Horn
shown with 802 Driver

Smooth distribution
No "horn" sound
Cast aluminum
Wide frequency range
Flexible mounting facility
Sectoral
Exponential

Altec sectoral horns provide inexpensive, space saving means to excellent reproduction of middle and high frequencies. Their straight exponential design directs sound waves into the proper distribution pattern without interfering with their natural propagation. This freedom from interference results not only in smooth, effective distribution control but also in an outstandingly good frequency response. The horns are cast of aluminum and have stiffening ribs to assure freedom from resonance and ring.

The 511A with a lower limit of 500 cycles may be used as the high frequency component of large two-way systems for full range music and speech reproduction or alone as an excellent projector in paging, public address, and announcing systems. It accommodates the Altec 802 or 730 Driver Speakers. For two-way system use, the Altec 500 cycle Dividing Network should be ordered. A universal mounting bracket is provided with each 511A Horn for easy mounting in any position.

The 811B Horn has a lower limit of 800 cycles and is designed specifically for use in two-way systems. It provides high fidelity reproduction from 800 to 22,000 cycles. The 802 Driver and 800 cycle Network should be used with this horn.



1515 S. Manchester Ave., Anaheim, Calif.
New York, Los Angeles

SPECIFICATIONS

	511A	811B
Low Frequency Cutoff:	500 cps	800 cps
Distribution:		
Horizontal	90°	90°
Vertical	40°	40°
Type Driver and Output (SPL, db/.0002 dyne/cm², at 4' for 1 watt input):	730A — 105 db 802D — 107.5 db (500-2500 cps warble)	802D — 107.5 db (1000-2500 cps warble)
Dimensions:		
Height	10 ⁵ / ₈ "	8 ⁵ / ₈ "
Width	23 ⁵ / ₈ "	18 ³ / ₈ "
Depth	18 ¹ / ₂ "	14"
Shipping Weight:	18 lbs.	11 lbs.

ARCHITECTS AND ENGINEERS SPECIFICATIONS

511A

The loudspeaker horn shall be of the straight sectoral type with exponential expansion. Folded or re-entrant type horns will not be acceptable because of phase cancellation occurring in the bends of the air column and lack of uniform distribution. It shall produce a uniform sound pressure level of 105 db at a distance of 4 feet from the horn mouth with 1 watt input when equipped with the Altec 730A compression-type driver or 107.5 db with 802D. The distribution angle shall be 90° horizontal and 40° vertical. It shall have a low frequency cutoff of 500 cycles and shall be of heavy weatherproofed construction of cast aluminum. A universal mounting bracket shall be supplied with each horn for easy mounting.

Horn shall be Altec Lansing Model 511A.

811B

The loudspeaker horn shall be of the straight sectoral type with exponential expansion and straight throat. Folded or re-entrant type horns will not be acceptable because of phase cancellation occurring in the bends of the air column, distortion, and lack of uniform distribution.

When equipped with the 802D compression-type driver, it shall produce a uniform sound pressure level of 107.5 db at a distance of 4 feet from the horn mouth with 1 watt input and over a horizontal angle of 90° and a vertical angle of 40°. It shall have a low frequency cutoff of 800 cycles and shall be of heavy construction of cast aluminum. It shall have a mounting flange to permit bolting through a baffle board or ceiling.

Horn shall be Altec Lansing Model 811B.



Smooth response
High efficiency
High power capacity
Edge wound voice coil
Viscous damped
Die-cast frame
Heavy Alnico V magnet
Field replaceable cone
Low distortion

The 515 speaker has been designed specifically for use as a bass transducer in major sound systems where efficiency and high power handling capacity are important. Its frequency range has been limited to 30–1000 cps and, for smoothest overall system performance it should be used with a 500 cps crossover network.

This husky speaker has a continuous power handling capacity of 35 watts and a peak capacity of 50 watts. Its sturdy die-cast frame is positive insurance against misalignment and voice coil rubbing. The Alnico V magnetic structure is unusually large to provide both high efficiency and positive control over cone movement at high power levels and wide excursion. The edge wound copper voice coil is capable of handling large amounts of electrical energy without danger of over-heating, shorting or other damage.

This speaker, which is used in the larger Altec "Voice of the Theatre" systems, is without equal for the smooth, efficient reproduction of bass tones at high power levels; a quality of extreme importance in the design of large, full-range sound systems for voice and music reproduction.



1515 S. Manchester Ave., Anaheim, Calif.
New York, Los Angeles

SPECIFICATIONS

Power:	35 watts (peak 50 watts)
Frequency Response:	30—1000 cps
Impedance:	16 ohms
Voice Coil Diameter:	3"
Diameter:	15 ³ / ₁₆ "
Magnet Weight:	4.4 lbs.
Mounting Hole Diameter:	13 ¹ / ₄ "
Depth:	7 ³ / ₄ "
Weight:	26 lbs.

ARCHITECTS AND ENGINEERS SPECIFICATIONS

The low frequency speaker shall be 15" in diameter. It shall have a minimum sensitivity of 56 db (EIA) measured on axis. The voice coil shall be at least 3" in diameter and shall be of edge wound copper ribbon operating in a magnetic field of at least 14,750 gauss derived from an Alnico V magnet of at least 4.4 pounds. Speakers with smaller voice coils or round wire will not be acceptable under this specification. The free air resonance of the speaker shall not exceed 45 cycles.

The speaker shall have a continuous power rating of at least 35 watts and a peak power rating of at least 50 watts. The frequency response shall be uniform from 30 to 500 cycles.

The speaker shall be Altec Lansing Model 515.

730A Driver Loudspeaker

730A

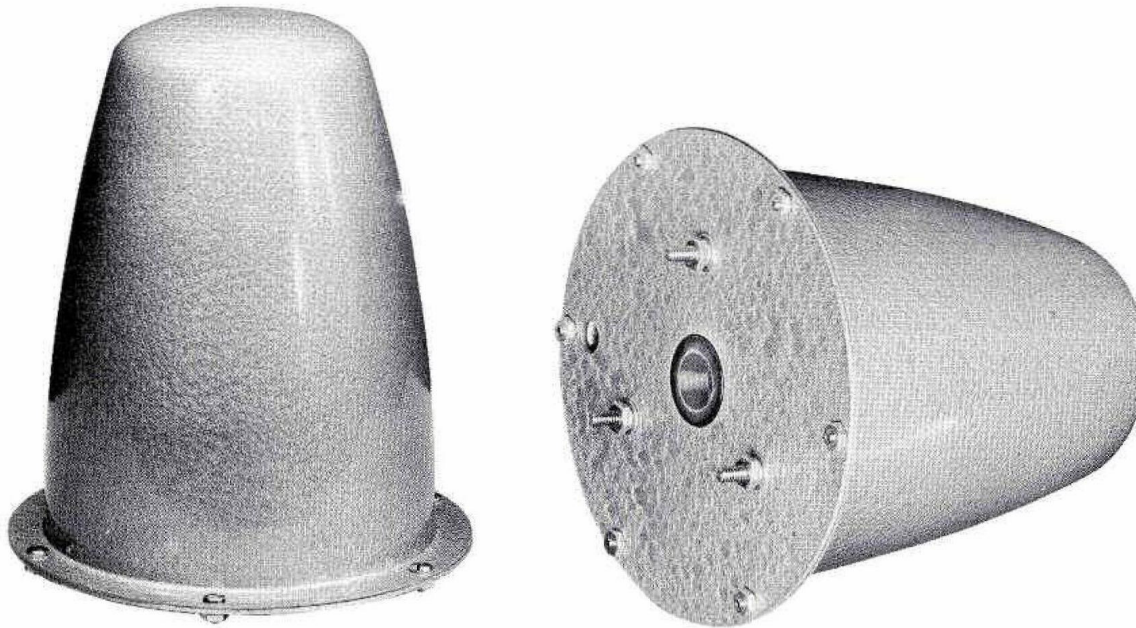

Rugged
40 watt capacity
Weatherproof
High efficiency
Smooth response
70 v facility
Fits many horns

The Altec 730A is a high quality, rugged, weatherproof driver loudspeaker for use in public address and paging systems on either the 511A sectoral horn or any Altec multicellular horn.

The electro-acoustic design of the 730A has been carefully engineered to provide the best operational features at low cost. It may be driven to 40 watts continuously or to peaks of 80 watts. Its excellent efficiency provides valuable economies in required amplifier power capacity. Although the weather resistant phenolic diaphragm is field replaceable, as with all Altec driver loudspeakers, it is so rugged that replacements are almost non-existent.

The 730A is equipped with a weatherproof housing which is easily removed. Threaded holes are provided inside the case for mounting an appropriate 70 v line transformer.

With its outstanding efficiency, moderate price, and wide, smooth frequency response, the 730A is ideal for the majority of outdoor and larger indoor speech reinforcement and announcing systems.



1515 S. Manchester Ave., Anaheim, Calif.
New York, Los Angeles

SPECIFICATIONS

Power:	40 watts continuous; 80 watts peak
Frequency Response:	200-7,000 cps
Impedance:	8 ohms
Average Sound Level:	(Warble frequency 500-2,500 cps 4' from mouth of 30" trumpet) 109.2 db ref. .0002 dyne/cm ² for 1 volt-ampere input
Protection:	Low frequencies should be attenuated by network providing 6 db loss per octave with 300 cps attenuated 3 db; for 80 watt peak rating, attenuate 500 cps 3 db
Outdoor Use:	Weather proof construction
Dimensions:	Diameter 5 $\frac{7}{8}$ ", Height 7"
Finish:	Gray

ACCESSORIES

30474 Adaptor to fit multicellular horn throats.

3A Attachment mounts 730A to any standard 1 $\frac{3}{8}$ " — 18 threaded throat.

ARCHITECTS AND ENGINEERS SPECIFICATIONS

The loudspeaker driver unit shall employ a phenolic diaphragm and a voice coil of round copper wire. The entire diaphragm voice coil assembly shall be field replaceable without special tools or skills. This shall be interpreted to mean that the speaker shall incorporate self-centering dowels or other means to insure proper spacing. With 1 watt input, it shall produce a sound pressure level of at least 109.3 db over the warble band of 500,2,500 cycles at a distance of four feet. Single frequency measurements will not be acceptable under this specification. The frequency response shall be uniform from 200 to 7,000 cycles, and it shall be capable of handling a continuous power level of 40 watts (80 watts peak). Provisions shall be incorporated to permit mounting a 70 volt matching transformer on the speaker and the entire assembly shall be enclosed in a weatherproofed housing.

The driver loudspeaker shall be Altec Lansing Model 730A.

755A Loudspeaker

755A



Wide frequency response

Wide angle of distribution

Eight watt power handling capacity

Compact size

Shallow depth

Excellent voice and music distribution

Minimum loss of high frequencies at any angle

Ideal for multiple installations

Heavy-duty steel frame

The Altec 775A is the highest quality 8" loudspeaker available. Its smooth, extended frequency response is superior to most larger speakers. Its compact size makes it ideal for public address installations.

In any low level distribution system for wired music, program distribution, calling systems or public address, the Altec 755A will provide superior performance. The unique pancake design provides very smooth distribution over a wide angle without high frequency loss. The extended 70 to 13,000 cycle range assures crisp, intelligible speech and good music reproduction.

The frame of the 755A is heavy gauge steel and the entire unit has been designed for continuous, trouble-free service. Shallow depth and small diameter make it possible to mount the 755A in limited space in walls and ceilings; and, due to its unusual design, the unit performs well in small enclosed volumes. A sealed enclosure of two cubic feet is optimum.

With its small size, wide distribution angle and outstanding frequency range, the 755A provides greater installation convenience and higher audio quality than any other speaker of comparable size.



1515 S. Manchester Ave., Anaheim, Calif.

New York Los Angeles

SPECIFICATIONS

Power:	8 watts
Frequency Response:	70 to 13,000 cps
Impedance:	8 ohms
Voice Coil Diameter:	2"
Diameter:	8 $\frac{3}{8}$ "
Magnet Weight:	1.3 lbs.
Mounting Holes:	4 equally spaced at 7 $\frac{5}{8}$ "
Baffle Opening:	7"
Depth:	3 $\frac{1}{8}$ "
Weight:	5 lbs.

ARCHITECTS AND ENGINEERS SPECIFICATIONS

The loudspeaker shall be 8" in diameter, Altec Lansing 755A. The speaker shall have a minimum sensitivity of 48.5 db (EIA) when measured on axis and a sensitivity of not less than 46.0 db at an angle 45° off axis. The loudspeaker shall have a continuous power rating of at least 8 watts. The voice coil shall be 2" in diameter and operate in a magnetic field of at least 10,000 gauss derived from an Alnico V magnet of at least 1.3 pounds. Free air resonance shall not be higher than 90 cps and the response shall be smooth to 13,000 cps. Resonance figures on the cone alone will not be acceptable under this specification. The loudspeaker shall be built in a heavy steel frame to prevent distortion and shall be sealed against dirt and magnetic dust.

The speaker shall be Altec Lansing Model 755A.

802D Driver Loudspeaker

802D



500-22,000 cycle range
High fidelity quality
Aluminum diaphragm
Ribbon voice coil
30 watt capacity
Faithful reproduction
Low distortion

The Altec 802D Driver Speaker has been designed for use with the 511 and 811 type sectoral horns in the finest two-way high fidelity systems. When used with one of these horns the 802D will provide an exceptionally smooth response up to 22,000 cycles, one-half octave beyond the range of the human ear. It has an aluminum alloy tangential diaphragm and an edge-wound aluminum ribbon voice coil. This entire assembly is easily replaced in the field without special skills or tools.

When combined with the proper low frequency speakers and cabinets, the 802D and horn become a major component in a system capable of reproducing all of the tones audible to the human ear. Such true high fidelity systems find great use in churches, night clubs and moderate size auditoriums where realism of reproduction is a major factor in success of the sound system.



1515 S. Manchester Ave., Anaheim, Calif.

New York. Los Angeles

SPECIFICATIONS

Power:	30 watts (with 800D or 500C network)
Frequency Response:	500-22,000 cps
Impedance:	16 ohms
Average Sound Level:	(Warble frequency 500-2,500 cps 4' from mouth of 30" trumpet) 111.7 db ref. .0002 dynes/cm ² for 1 volt-ampere input
Protection:	500C should be used when driver is mounted on 511A Horn 800D should be used when driver is mounted on 811B Horn
Dimensions:	Diameter 4½" Height 3⅞"
Finish:	Gray
Weight:	7 lbs.

ACCESSORIES

See sheets on Horns, Transformers, and Networks.

ARCHITECTS AND ENGINEERS SPECIFICATIONS

The driver loudspeaker unit shall employ an aluminum diaphragm with tangential compliance and a voice coil of edge wound aluminum ribbon. The voice coil diameter shall be at least 1¼" and the voice coil gap shall have a flux density of at least 15,250 gauss. The entire diaphragm voice coil assembly shall be field replaceable without special tools or skills. This shall be interpreted to mean that the speaker shall incorporate self-centering dowels or other means to insure proper spacing. With 1 watt input, the speaker shall produce a sound pressure level of at least 111.7 db at a distance of 4 feet with a warble band of 500 to 2,500 cycles. Single frequency measurements will not be acceptable under this specification. The frequency response shall be uniform over the range: (choose one) (a) 500 to 22,000 cycles with proper 500 cycle horn and network, (b) 800 to 22,000 cycles with proper 800 cycle horn and network.

The driver loudspeaker shall be Altec Lansing Model 802D.

803A Loudspeaker

803A



Smooth response
High efficiency
Rugged construction
High fidelity quality
Low distortion
Heavy Alnico V magnet
Edge-wound voice coil
Economical

The 803A is a bass loudspeaker of moderate power handling capacity for use in two-way speaker systems in full frequency range public address and music reproduction installations. It is designed to provide smooth response over the range from 30 to 1600 cps when mounted in a proper enclosure and may be used with either an 800 cps or 500 crossover network.

The smooth, undistorted response of this outstanding speaker has been achieved through the use of an exceptionally efficient Alnico V magnetic structure, an edge-wound ribbon voice coil and a stable viscous-damped cone. The high efficiency of the 803A helps substantially to reduce system costs since it will reproduce sound levels comparable to less efficient speakers with only a fraction of the amplifier power required by such units.

Singly or in multiple configurations, the 803A, when used with the proper high frequency horn and driver, will provide true high fidelity performance for the finest music reproduction and the most accurate and natural sounding speech in moderate powered public address, sound and music distribution systems.



1515 S. Manchester Ave., Anaheim, Calif.

New York, Los Angeles

SPECIFICATIONS

Power:	30 watts
Frequency Response:	30—1600 cps
Impedance:	16 ohms
Voice Coil Diameter:	3"
Diameter:	15 $\frac{3}{8}$ "
Magnet Weight:	2.4 lbs.
Mounting Hole Diameter:	13 $\frac{1}{4}$ "
Depth:	7"
Weight:	17 $\frac{1}{2}$ lbs.

ARCHITECTS AND ENGINEERS SPECIFICATIONS

The low frequency speaker shall be 15" in diameter. It shall have a minimum sensitivity of 54 db (EIA) measured on axis. The voice coil shall be approximately 3" in diameter and shall be of edge wound copper ribbon operating in a magnetic field of at least 13,500 gauss derived from an Alnico V magnet of at least 2.4 pounds. Speakers with smaller voice coils or round wire will not be acceptable under this specification. The free air resonance of the speaker shall not be greater than 45 cycles. The speaker shall have a continuous power rating of at least 30 watts and shall have a uniform frequency response from 30 to 1600 cycles.

The speaker shall be Altec Lansing Model 803A.

Low Frequency Horns

L-F
HORNS

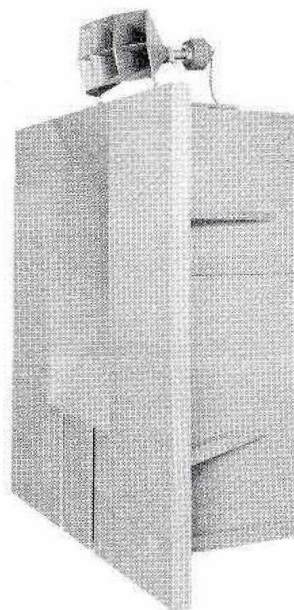
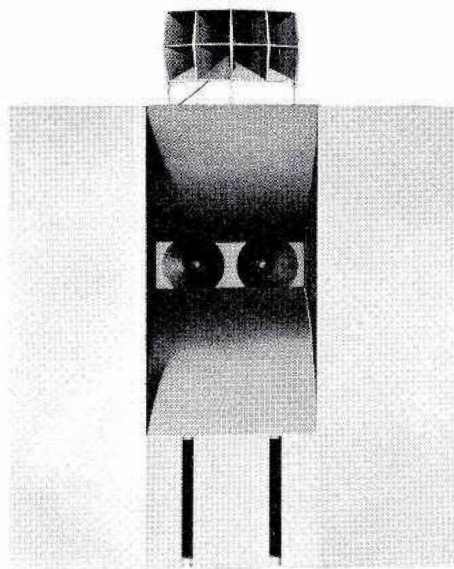

210 Horn with speakers installed

Direct radiating
Rugged construction
True bass reproduction
Efficient bass projection
Wide distribution

These larger low frequency horns, used in the "Voice of the Theatre" speaker systems in over 12,000 motion picture theatres, auditoriums, and arenas, insure proper loading and performance of the low frequency loudspeakers. They are of heavy construction and are thoroughly braced to prevent vibration. The short exponential expansion provides proper spatial phasing with the high frequency horn and assists in the all important mid-range projection. The horns are front loading and do not employ folds or bends which introduce holes in the frequency response of the system. The back wave of the speaker is radiated at lowest frequencies through a bass reflex type port designed to avoid the boom and false accentuation often associated with public address systems. The heavy construction of the horns permits them to be mounted in the walls and ceilings of auditoriums, or suspended overhead in large arenas. They may be used with either the 803A or 515 loudspeakers. High frequency components should be used in conjunction with these low frequency units for full range two-way systems.



1515 S. Manchester Ave., Anaheim, Calif.

New York, Los Angeles

SPECIFICATIONS

Horn Model Number (a)	Number of Low Frequency Speakers Per Horn (b)	Height	D I M E N S I O N S Width (c)		Depth	Weight (d)
			With Wings	Without Wings		
210	2	84"	80½"	32½"	39½"	560 lbs.
410	4	84"	103"	65"	39½"	890 lbs.
825	1	42"	30"	24"	100 lbs.

ARCHITECTS AND ENGINEERS SPECIFICATIONS

The low frequency horn shall be of the direct radiating type and shall measure (c), and weigh in the order of (d). It shall consist of a short exponential horn designed to match the phasing of the high frequency horn specified elsewhere. Horn systems that employ folds or bends in the acoustical path, either front or back loaded, will not be acceptable under this specification because of their inherent frequency cancellation.

The horn shall be of heavy plywood at least ¾" stock and shall be fully braced with 2 x 3 and 2 x 4 frames. It shall be designed to mount and properly load (b) 15" low frequency speakers of the type specified elsewhere.

Low frequency horn shall be Altec Lansing Model (a).

Note: Fill in (a), (b), (c), and (d) from specifications.)

Multicellular Horns

Horns



High efficiency
Rugged
Controlled distribution
Effective projection
10 models
High power ability with
multiple drivers
True reproduction

The Altec Lansing Multicellular Horn line offers a choice of three low frequency cutoffs and a wide range of distribution patterns provided by units from 8 to 18 cells each. They may be used with Altec 288B, 290C, or 730A compression-type drivers. Each horn is constructed of individual metal cells, each cell identical. The several cells are then put together in the desired form and all spaces between filled with a special damping compound. The resulting horn is of extremely rugged construction and free from any internal vibration. This design insures accurate control of the distribution pattern over a wide frequency range with highest quality of performance.

In determining which model should be selected, three factors should be considered: (1) select the distribution pattern that will best cover the required area; (2) determine the number of units to be adapted to the horn, based on the power requirement to provide the desired sound pressure level; (3) favor the horns with lower cutoff frequencies when sound is to be projected comparatively long distances or in areas of high ambient noise level. The greater length and mouth area of these horns provide substantially improved control of the beam width over the full frequency range, and they have been used successfully in foundries and metal working departments where it was believed no sound system could be installed and where all other types had failed.

These horns and drivers may be used without bass speakers for speech reinforcement systems for outdoor stadiums (using the weatherproofed 290C driver), indoor arenas or factories (using either the 290C or 288B driver). When used as a part of a two-way system with Altec Lansing low frequency horns, they provide full range reproduction for the largest theatre or auditorium.



1515 S. Manchester Ave., Anaheim, Calif.

New York, Los Angeles

MULTICELLULAR HORN PERFORMANCE CHART

Horn Model (a)	Number of Drivers (b)	Type Driver and Output** (c)	Distribution Pattern (d)	Cut-Off Frequency (e)	Cell Configuration	Horn Dimensions			1 Unit	Throat Code Number 2 Units
						L	W	H		
803	1	288B — 111 db 290C — 107 db 730A — 105 db	35° x 70°	300 cps	2 x 4	26½	33	17½	30162*	
804	2	288B — 110 db 290C — 106 db 730A — 104 db	35° x 70°	400 cps	2 x 4	23½	32	17½		30172*
805	1	288B — 109 db 290C — 105 db 730A — 103 db	40° x 80°	500 cps	2 x 4	17½	24½	14¾	30162*	
1003	1 or 2	288B — 109 db 290C — 105 db 730A — 103 db	35° x 90°	300 cps	2 x 5	25½	38	17½	30210*	30170*
1004	4	288B — 109 db 290C — 105 db 730A — 103 db	40° x 100°	400 cps	2 x 5	21	38½	17½		
1005	1 or 2	288B — 108 db 290C — 104 db 730A — 102 db	40° x 100°	500 cps	2 x 5	17¼	30	14¾	30210*	30170*
1504	4	288B — 108 db 290C — 104 db 730A — 102 db	60° x 105°	400 cps	3 x 5	21	38¾	25		
1505	1 or 2	288B — 106 db 290C — 102 db 730A — 100 db	60° x 105°	500 cps	3 x 5	16¾	30½	20	30166*	30172*
1803	1 or 2	288B — 106 db 290C — 102 db 730A — 100 db	53° x 105°	300 cps	3 x 6	27½	44	25	30166*	30172*
1804	4	288B — 106 db 290C — 102 db 730A — 100 db	60° x 125°	400 cps	3 x 6	23½	44	25		

*One 30474 Adapter required in addition for each 730A Driver.

**SPL, db/.0002 dyne/cm², at 4 feet for input of 1 watt, 500 to 2,5

ARCHITECTS AND ENGINEERS SPECIFICATIONS

The high frequency horn shall be of the multicellular type, equipped with proper throat and (b) con driver. As specified elsewhere, it shall produce a uniform sound pressure field of (c) db at a distance and over a field of distribution of (d) with 1 watt input of 500 to 2,500 cps warble. The low frequency shall be (e). The horn shall be constructed of individual weatherproofed metal cells with a special facing material between the cells. The cells shall all be straight with an exponential expansion. Folded or r horns will not be acceptable. The horn shall be equipped with mounting brackets both on the front and appropriate cast throat.

Multicellular horn shall be Altec Lansing Model (a).

(NOTE: Fill in proper values and numbers from Horn Performance Chart.)

Dividing Networks and Diaphragm/Voice Coil Assemblies

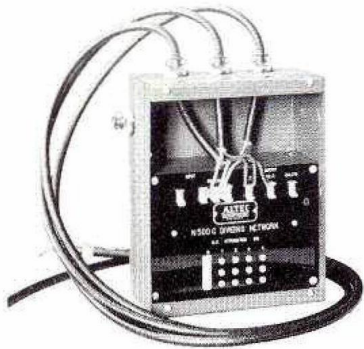

500C Network



800D Network



2021 Diaphragm Voice Coil Assembly

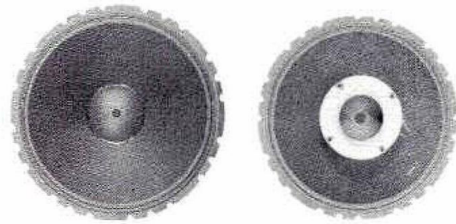

20248 Diaphragm/Voice Coil Assembly

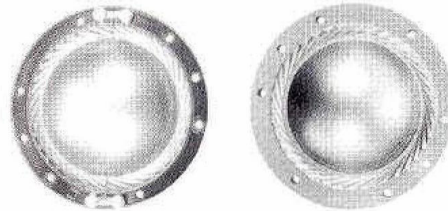

500C DIVIDING NETWORK

This Network is used to effect a 500 cycle crossover in two-way loudspeaker systems consisting of Altec 515 or 803 Low Frequency Speakers and Altec 288, 290, or 802 High Frequency Drivers used on 500 cycle horns. It also provides for high level paging and public address. Five values of high frequency attenuation are provided.

800D DIVIDING NETWORK

The 800D, like the 500C, is a full section network of highest quality. Provides a smooth crossover at 800 cycles between the Altec 803 Loudspeaker and 802 Driver on an 800 cycle horn. The 800D has four 1 db attenuation steps for high frequency adjustment.

SPECIFICATIONS

	500C	800D
Crossover:	500 cycles	800 cycles
Impedance:	16 ohms	16 ohms
Dimensions:	10" H 8" W 4 $\frac{1}{16}$ " D	6" H 4 $\frac{3}{4}$ " W 2 $\frac{5}{8}$ " D
Weight:	22 lbs.	8 lbs.



1515 S. Manchester Ave., Anaheim, Calif.

New York, Los Angeles

DIAPHRAGM/VOICE COIL ASSEMBLIES

The field replaceable diaphragm and voice coil assemblies for Altec loudspeakers are listed below. Care should be exercised when making a replacement; until properly mounted, these assemblies are extremely delicate.

Loudspeaker	Diaphragm/Voice Coil Assembly Code Number
288B	20221
290C	20646
400B	20509
401A	20748
408A	20733
412A-B	20729
415A	20730
515 & 604B L.F.	20248
555	20303
600B	20464
601A-B L.F.	20592
603B	20419
604A-B L.F.	20593
604B-C-D H.F.	20502
604C L.F.	20603
604D L.F.	20841
720A	ES-670650-2
713C	BL-163147
730A Head Assembly	20607
755A	BO-162761
802B-C-D & 604 H.F.	20275
803A	20476

AL-1436-1

PRINTED IN U.S.A.

Utility Cabinets

Utility

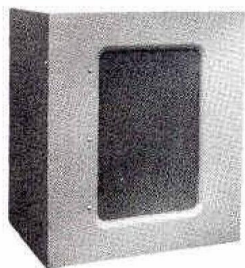

612

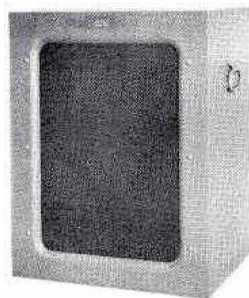

614

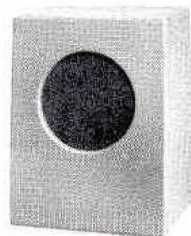

618

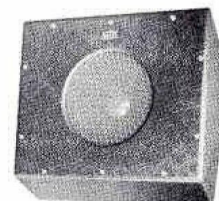

622B

Acoustically engineered
Heavy construction
Long lasting finish
Right size for every need

In applications where it is not desirable to conceal the loudspeakers, these compact enclosures give optimum performance in minimum space. Their design provides excellent bass response and clean, undistorted mid-range. They are recommended for any installation to provide proper baffling and mounting.

Heavy wood construction, sturdy bracing, and proper application of acoustical material permit larger power output without cabinet rattle or boom. They may be permanently mounted or used portably for roving public address.

The cabinets are finished in protective industrial paint and will last indefinitely under normal use. Available with baffles pre-drilled to mount 8", 12", or 15" loudspeakers.



1515 S. Manchester Ave., Anaheim, Calif.

New York Los Angeles

Chart for Selecting Code Number for Above Specifications

Size of Loudspeaker (a)	Suffix to Model Number to Denote Full Type Number (b)
15"	A
12"	B
8"	C

Example: 612A, 614B, 612C

612 CABINET ARCHITECTS AND ENGINEERS SPECIFICATIONS

The speaker cabinet shall be of the large utility type measuring 29½" H, 25½" W, and 17¾" D. It shall be of heavy wood construction in gray industrial finish. It shall be of the bass reflex type. Cabinets employing folded horns or tuned slots will not be acceptable under this specification because of their inherent poor reproduction of middle frequencies. The cabinet shall contain 6 cubic feet and weigh at least 63 pounds. The cabinet shall be furnished with "grilled" opening for one (a) loudspeaker.

The cabinet shall be Altec Lansing Model 612 (b).

614 CABINET ARCHITECTS AND ENGINEERS SPECIFICATIONS

The speaker cabinet shall be of the medium size utility type measuring 24¾" H, 18¾" W, and 14¼" D. It shall be of heavy wood construction in gray industrial finish. It shall be of the bass reflex type. Cabinets employing folded horns or tuned slots will not be acceptable under this specification because of their inherent poor reproduction of middle frequencies. The cabinet shall be supplied complete with carrying handles. It shall contain 3 cubic feet and weigh at least 39 pounds. The cabinet shall be furnished with "grilled" opening for one (a) loudspeaker.

The cabinet shall be Altec Lansing Model 614 (b).

618 CABINET ARCHITECTS AND ENGINEERS SPECIFICATIONS

The speaker cabinet shall be of the small size utility type measuring 22" H, 17" W, and 13¼" D. It shall be of heavy wood construction in industrial gray finish. It shall be fully sealed without slots or tuning. The cabinet shall contain 2.3 cubic feet and weigh at least 22 pounds. The cabinet shall be furnished with a "grilled" opening for one (a) loudspeaker.

The cabinet shall be Altec Lansing Model 618 (b).

622B WALL CABINET ARCHITECTS AND ENGINEERS SPECIFICATIONS

The speaker cabinet shall be of the wall mounting type measuring 22" W, 17" H, and 13¼" D (maximum) or 7¼" D (minimum). It shall be of heavy wood construction with an attractive brown and gold finish. It shall be fully sealed without slots or tuning. The cabinet shall contain 1.6 cubic feet and weigh at least 22 pounds. The cabinet shall be furnished with "grilled" opening for one 12" loudspeaker.

The cabinet shall be Altec Lansing Model 622B.

70 Volt Line Transformers

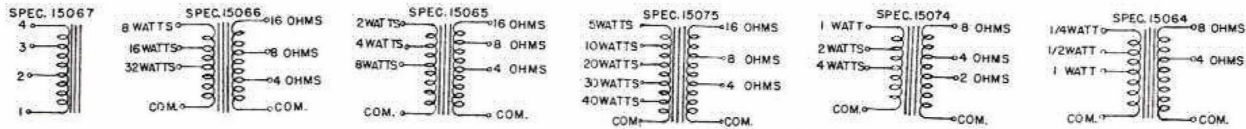
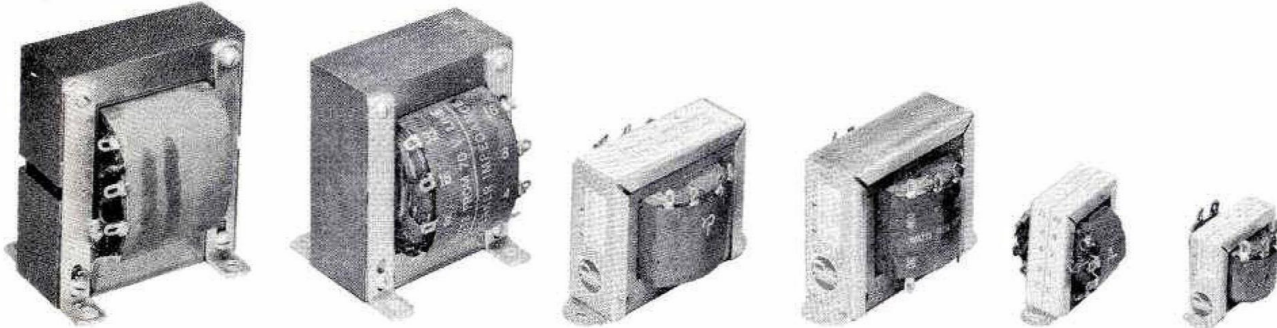

Superior quality by Peerless

Lowest insertion loss

Full rated power within 1 db
over entire frequency range

Selectable wattage to speaker

.25 to 140 watt power range

Size for every need

EIA has standardized the output circuits of power amplifiers for sound distribution systems on the basis of a 70.7 volt loudspeaker line. This means that an amplifier should have an output impedance which will, under test conditions, supply 70.7 volts of single frequency power at its maximum rated output. The 70 volt system works as follows:

- (1) A matching transformer is required for each loudspeaker. The secondary of the transformer is tapped to match the loudspeaker impedance (such as 4, 8, 12, and 16 ohms).
- (2) The primary of the transformer is tapped over a suitable range of impedances which are bracketed somewhere by the power rating of the unit. The proper primary tap is chosen so that the loudspeaker will draw the required watts when 70 volts are applied.
- (3) In practice, the connection for a number of loudspeakers then becomes simple: The power needed for each loudspeaker location is determined and a transformer having the appropriate power taps is selected.
- (4) The power requirements for all loudspeakers are added up and an amplifier chosen which is capable of supplying at least this power. All loudspeaker transformer inputs should then be connected in parallel to the 70 volt output of the amplifier.

The 70 volt line transformers are precision-made to highest standards by Peerless Electrical Products, Division of Altec Lansing Corporation. Each transformer is designed to meet every requirement of the finest sound installation. Every transformer is Peerless quality—low insertion loss—large amounts of grain oriented core steel—high self-inductance—low leakage.

The "turns ratio" is adjusted in design to compensate for insertion loss to assure that the loudspeaker will receive the indicated amount of power. All transformers have a minimum of 3 steps of speaker power selection. The transformers are characterized by exceptionally high efficiency. Use of good transformers saves many costly watts of amplifier power and over-all system economy is the end result.



1515 S. Manchester Ave., Anaheim, Calif.

New York, Los Angeles

SPECIFICATIONS

(a) Type Number	(b) Frequency Range (1 db) ¹	(c) Audio Watts (70 V line)	(d) Secondary Load Imp. (ohms)	(e) Maximum Insertion Loss, db ²	H	Dimensions, In. D	W	Wt/lbs
15064 ⁴	60 15,000	1, .5, .25	8, 4	.7	1 $\frac{1}{16}$	2 $\frac{3}{16}$ ³	1 $\frac{1}{16}$	$\frac{3}{8}$
15074 ⁴	60 15,000	4, 2, 1 — or — 2, 1, .5 — or — 1, .5, .25	8, 4, 2 — or — 16, 8, 4 — or — 16, 8	1.2 — or — .8 — or — .5	1 $\frac{1}{16}$	2 $\frac{3}{16}$	1 $\frac{1}{16}$	$\frac{5}{8}$
15065	30 15,000	8, 4, 2	16, 8, 4	.5	2 $\frac{1}{16}$	4 $\frac{1}{8}$ ³	2 $\frac{1}{2}$	2 $\frac{1}{4}$
15066	30 15,000	32, 16, 8	16, 8, 4	.5	3 $\frac{13}{16}$	3 $\frac{3}{16}$	3 $\frac{3}{16}$	5
15075 ⁵	200 10,000	40, 30, 20, 10, 5	16, 8, 4	.5	2 $\frac{1}{16}$	4 $\frac{1}{8}$ ³	2 $\frac{1}{2}$	2 $\frac{1}{4}$
15067 (auto- trans- former)	30 15,000	140 — or — 75	16, 8 — or — 32, 16	.3 — or — .2	4 $\frac{3}{16}$	3 $\frac{1}{16}$	3 $\frac{3}{16}$	5 $\frac{3}{4}$
or, for impedance matching at other than 70 volts:								
		Watts	Impedances	Max. Insertion Loss				
		75	16, 8, 4	.5				
		— or —	— or —	— or —				
		30	8, 4, 2	1.0				

¹—Rated full power within 1 db over frequency range

²—Insertion loss for most unfavorable combinations of impedances

³—Dimensions over mounting flanges

⁴—May be mounted directly on 401A Loudspeaker

⁵—May be mounted directly on 730A and 50A Horn System

ARCHITECTS AND ENGINEERS SPECIFICATIONS

NOTE: After selecting transformer, insert proper values shown on 70 Volt Line Transformers Chart in blank spaces for the characteristic required.

The transformer shall deliver within 1 db of its full rated power over the entire range of (b) cycles with an insertion loss not greater than (e) db for the most unfavorable impedance combination. The primary shall be labeled in terms of powers of (c) watts delivered to the load when the transformer is connected to a 70 volt line, and the secondary shall be tapped for (d) ohm loads.

The 70 volt matching transformer shall be Altec Lansing Model (a).

The NEW...

Please turn page for details!

ALTEC LANSING Model 9200 Console

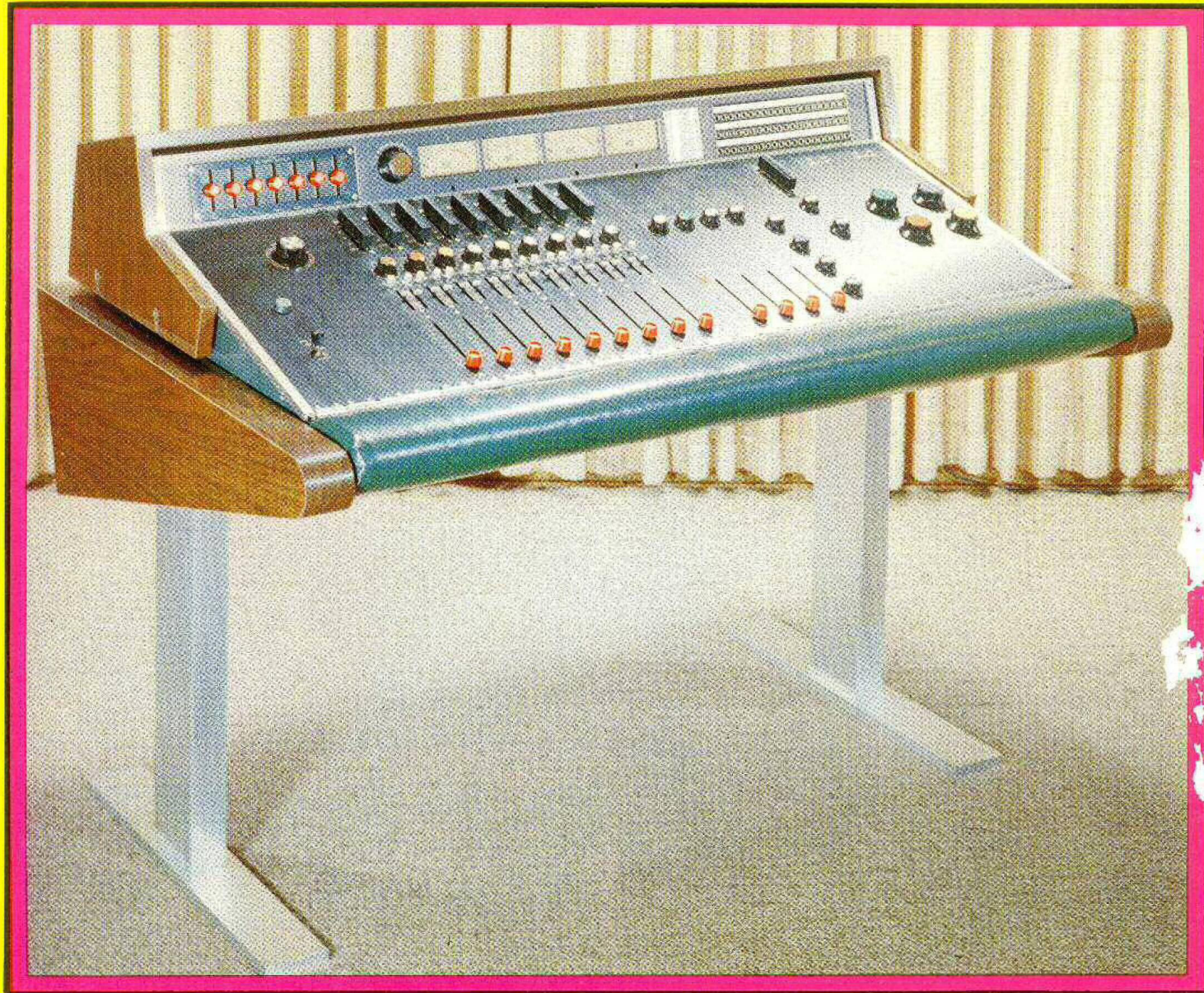

NOW... For the First Time in the Industry,
a User-Assembled Console
for the Professional!

MAIL THIS COUPON TODAY
FOR FREE, NEW, EXCITING
ALTEC LANSING Model 9200 Console Catalog



Fill out!
Cut out!
Mail today!

ALTEC LANSING
1515 S. MANCHESTER AVE. Dept. GM
ANAHEIM, CALIFORNIA 92803
Please send me a free copy of the Altec Lansing
Model 9200 Engineering Catalog.

Name _____ Position: _____
Company _____
Address _____
City _____ State _____ Zip _____

ALTEC LANSING presents the New Model 9200 Console

Altec's sensational new professional console — a basic, unitized enclosure for modular assembly from a complete line of components which may be selected from our catalog to meet the specific requirements of the professional.

- Highest professional quality for the professional user.
- Completely modular.
- Unlimited variations of component assembly.
- Basic cabinet and hardware, drilled, punched and beautifully finished — all difficult metal work is done. Eliminates need for special cabinet designs and costly single lot fabrication.
- Solid state catalogued components to be chosen by the user.
- Consoles may be assembled in multiples if needed.
- Cabinet enclosure may be ordered with cushion, base and cowl as required.

Simplified customizing by user for recording, re-recording, dubbing, broadcast studios, elaborate public address sound systems and any application for control console such as data processing, manufacturing controls, or military projects. You install what you need!

- Assembled from standard Altec professional components - makes financing easy if desired. Modification flexibility assures high resale value.
- A maximum of 27 strip modules per cabinet, each hinged for easy access. Available in 1¾ inch or 3½ inch width each. Can be mixed. Finished in satin black anodize.
- Accommodates up to 4 VU Meters for program plus 4 additional VU Meters mounted in a "stack" for echo send channels, plus graphic equalizer and jack panel on instrument panel.
- Unequaled versatility — one module may have a straight line pot, program equalizer, echo pot and a row of five channel selector keys. Another may use either straight line or rotary mixer; another for "talkback" including miniature dynamic microphone, slating keys and cue level control. You simply decide how you would like your dream console put together, and then quickly and easily assemble the modules in place.
- Human engineering carefully considered — completely functional for ease of operation.
- Basic cabinet has an overall length of 51 inches, 34 inches depth front to back by an average height of nine inches. Twenty-three 9470 Altec plug-in amplifiers may be accommodated inside the cabinet. Panel surface measures 18 inches from front to instrument panel.



Side view showing 9200, 9201 and 9202

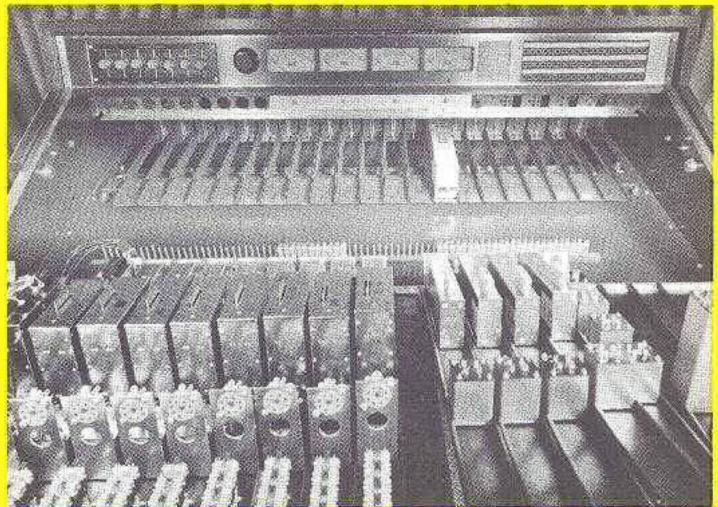

Front view with all modules in hinged forward position

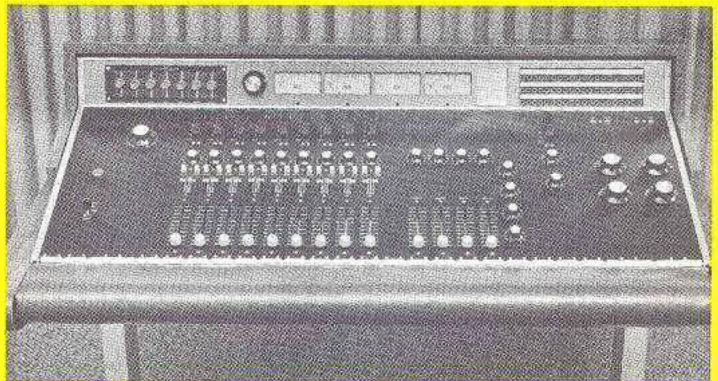

Front view of 9200 console

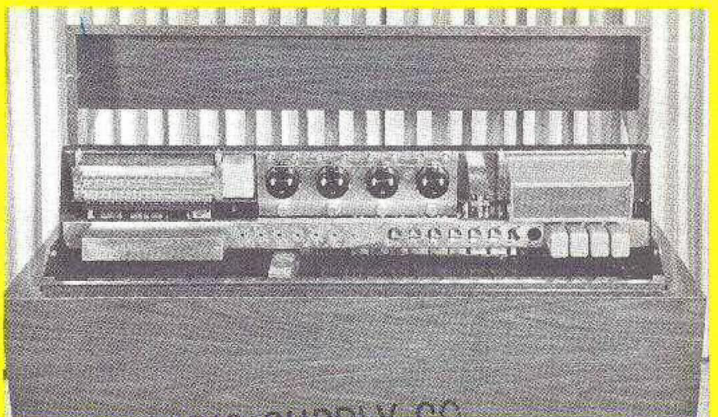

Rear view with cowl raised, showing easy accessibility to wiring



A Division of LTV Ling Altec, Inc.

ROCHESTER RADIO SUPPLY CO.
140 WEST MAIN STREET
ROCHESTER, 14, N. Y.
1515 SOUTH MANCHESTER AVE. ANAHEIM, CALIFORNIA • 92803