



STEREO CASSETTE DECK

MODEL GX-F90

ALSO APPLICABLE TO BLACK PANEL MODEL

SECTION 1	SERVICE MANUAL	3
SECTION 2	PARTS LIST	51
SECTION 3	SCHEMATIC DIAGRAM	72

SECTION 1

SERVICE MANUAL

TABLE OF CONTENTS

I.	TECHNICAL DATA	4
II.	DISMANTLING OF UNIT	5
III.	CONTROLS	6
IV.	PRINCIPAL PARTS LOCATION	7
V.	VOLTAGE AND CYCLE CONVERSION	8
	1. VOLTAGE CONVERSION	8
	2. CYCLE CONVERSION	8
VI.	CIRCUIT OPERATING PRINCIPLES	9
	1. SYSTEM CONTROL OPERATION	9
	2. EXPLANATION OF OPERATION OF DC BRUSHLESS DD CAPSTAN MOTOR (BLM-100)	27
VII.	MECHANISM ADJUSTMENT	31
	1. PLAY PLUNGER INSTALLATION POSITION ADJUSTMENT	31
	2. PAUSE PLUNGER INSTALLATION POSITION ADJUSTMENT	31
	3. REC LEAF SWITCH INSTALLATION POSITION ADJUSTMENT	31
	4. BRAKE PLUNGER INSTALLATION POSITION ADJUSTMENT	33
	5. PINCH ROLLER PRESSURE MEASUREMENT	33
	6. WINDING TORQUE MEASUREMENT IN EACH MODE	33
	7. TAPE SPEED ADJUSTMENT	33
VIII.	HEAD ADJUSTMENT	34
	1. TAPE GUIDE HEIGHT ADJUSTMENT	35
	2. REC/PB COMBINATION HEAD PROJECTION ADJUSTMENT	35
	3. REC/PB COMBINATION HEAD HEIGHT ADJUSTMENT	35
	4. REC/PB COMBINATION HEAD AZIMUTH ALIGNMENT ADJUSTMENT	35
IX.	AMPLIFIER ADJUSTMENT	36
	1. AMPLIFIER ADJUSTMENT	36
	2. BAR METER ADJUSTMENT	40
X.	DC RESISTANCE OF VARIOUS COILS	42
XI.	CLASSIFICATION OF VARIOUS P.C BOARDS	42
	1. P.C BOARD TITLES AND IDENTIFICATION NUMBERS	42
	2. COMPOSITION OF VARIOUS P.C BOARDS	43

For basic adjustments, measuring methods, and operating principles, refer to GENERAL TECHNICAL MANUAL.

I. TECHNICAL DATA

TRACK SYSTEM	4 track, 2 channel stereo system
TAPE	Philips type cassette
TAPE SPEED	4.76 cm/s \pm 0.5% (1-7/8 ips.)
WOW & FLUTTER	Less than 0.03% WRMS, 0.08% (DIN 45500)
FREQUENCY RESPONSE	25 to 15,000 Hz \pm 3 dB (-20 VU) LN tape 25 to 17,000 Hz \pm 3 dB (-20 VU) LH tape 25 to 17,500 Hz \pm 3 dB (-20 VU) CrO ₂ (SA) tape 25 to 9,000 Hz \pm 3 dB (0 VU) CrO ₂ (SA) tape 25 to 21,000 Hz \pm 3 dB (-20 VU) Metal tape 25 to 13,000 Hz \pm 3 dB (0 VU) Metal tape
DISTORTION (1,000 Hz "0" VU)	Less than 0.8% using LN tape 0.8% using LH tape 0.7% using CrO ₂ (SA) tape 0.6% using Metal tape
SIGNAL TO NOISE RATIO	Better than 58 dB using LN tape 60 dB using LH tape 61 dB using CrO ₂ (SA) tape 62 dB using Metal tape (Measured via tape with peak recording level) Dolby NR switch ON: Improves up to 10 dB above 5 kHz
ERASE RATIO	Better than 70 dB
BIAS FREQUENCY	100 kHz
HEADS	(3): Super GX recording head Super GX playback head and erase head (3 Head System)
MOTORS	(2): One FG servo DC motor for capstan drive (Direct Drive) One DC motor for reel drive
FF & REWIND TIME	60 sec. using a C-60 cassette tape
OUTPUT JACKS	Line (2): 410 mV (0 VU) Required load impedance: more than 20 kohms Phone: 100 mV/8 ohms
INPUT JACKS	Microphone (2): 0.25 mV (Input impedance 4.7 kohms) Required microphone impedance: 600 ohms Line (2): 70 mV (Input impedance 100 kohms)
DIN JACK	Input: 2 mV (Input impedance 10 kohms) Output: 0.3 V Required load impedance: more than 20 kohms
DIMENSIONS	440 (W) \times 105 (H) \times 370 (D) mm (17.3 \times 4.1 \times 14.6")
WEIGHT	9.8 kg (21.6 lbs)
POWER REQUIREMENTS	100V 50/60 Hz for Japan 120V 60 Hz for U.S.A. & Canada 110/120/220/240V switchable, 50/60 Hz for the other countries
POWER CONSUMPTION	JPN, CSA, AAL 38 W

* For improvement purposes, specifications and design are subject to change without notice.

* "Dolby" and the Double D symbol are trademarks of Dolby Laboratories

(Manufactured under license from Dolby Laboratories).

II. DISMANTLING OF UNIT

In case of trouble, etc. necessitating dismantling, please dismantle in the order shown in the photographs. Reassemble in reverse order.

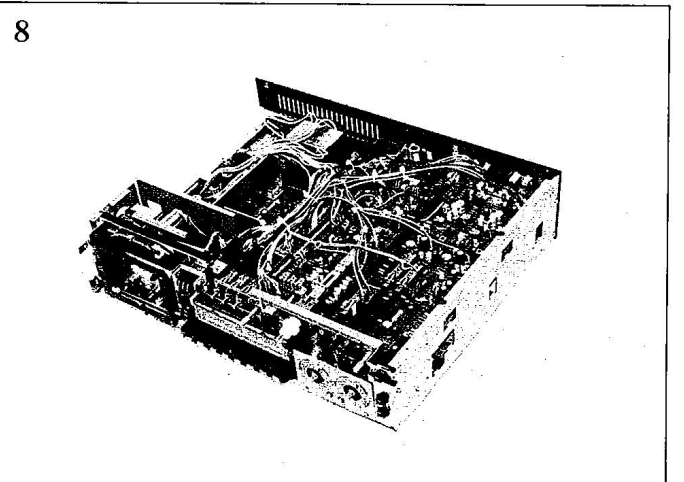
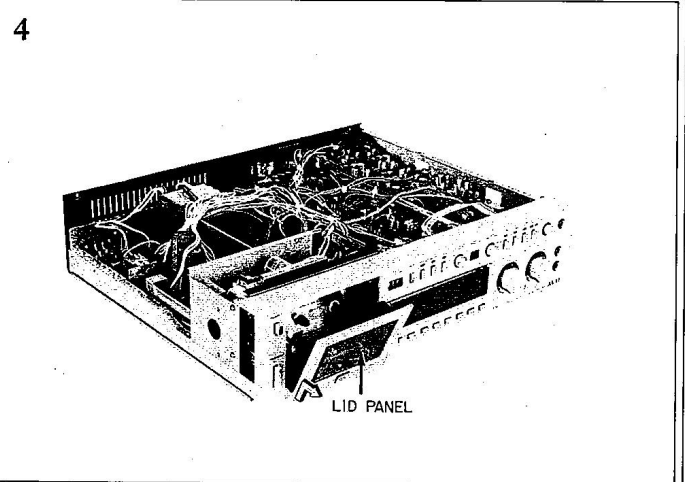
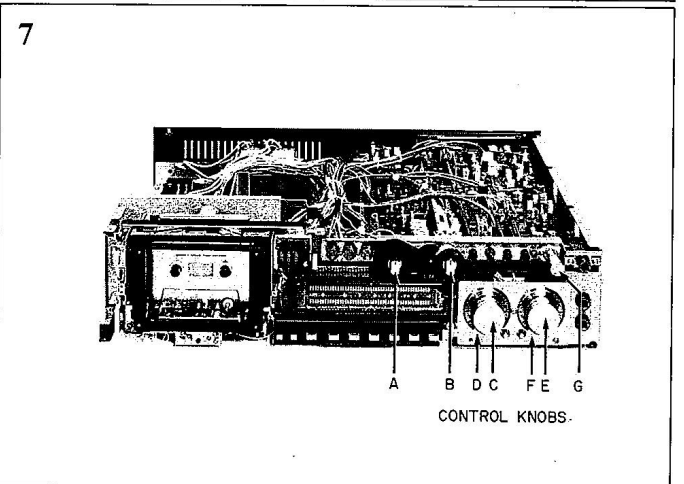
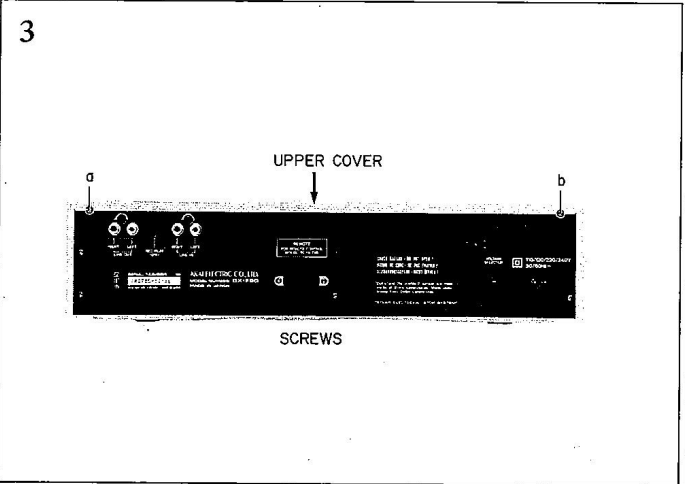
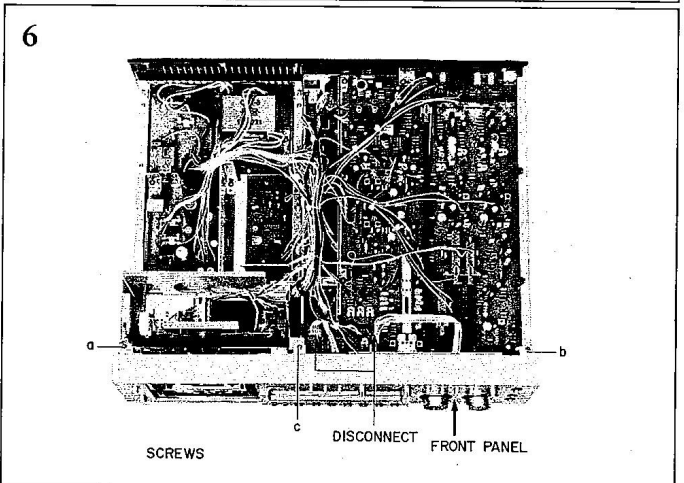
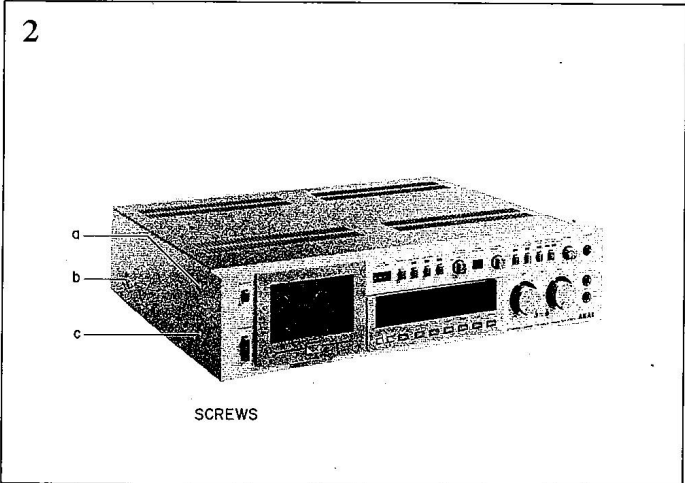
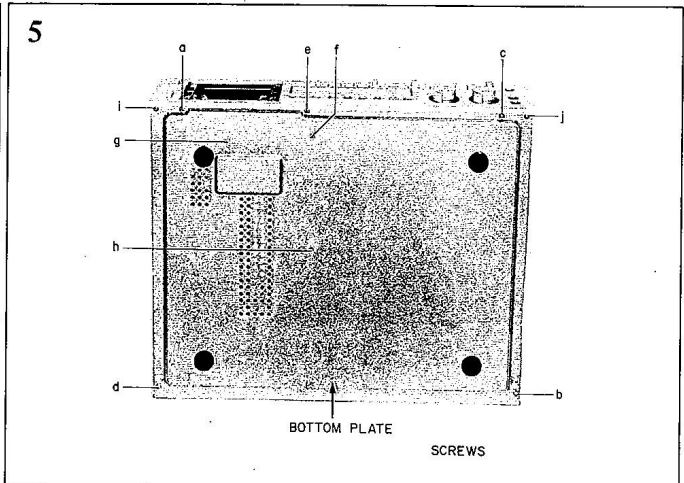
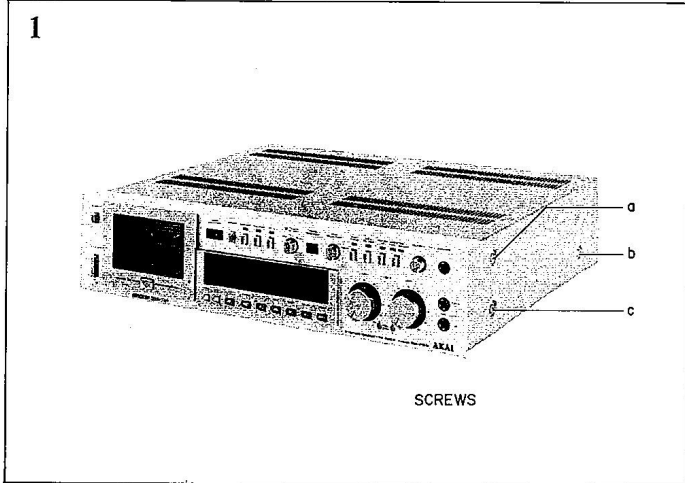

III. CONTROLS

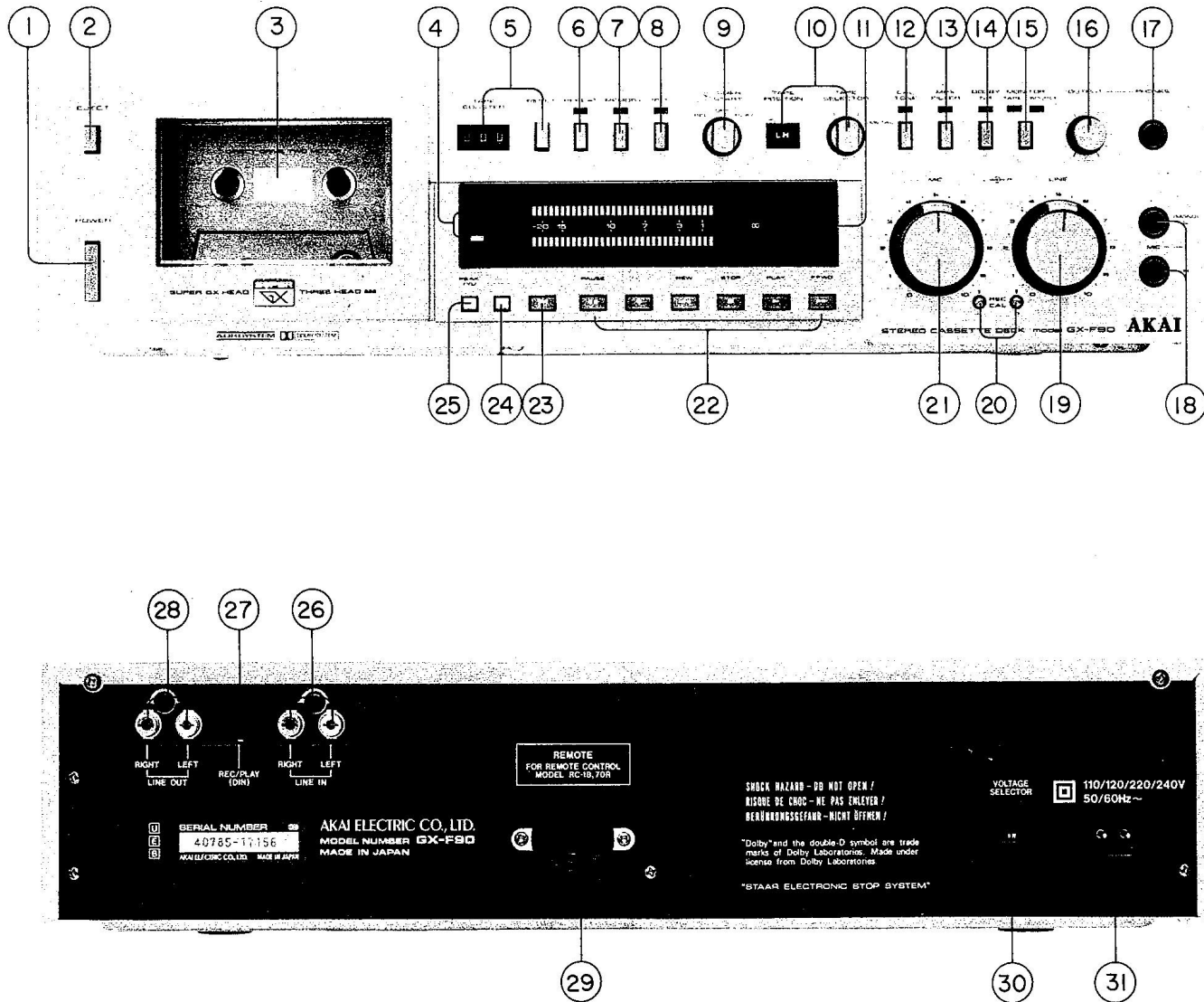

Fig. 1 Controls

- | | |
|---|--|
| <ol style="list-style-type: none"> 1. POWER SWITCH 2. EJECT BUTTON 3. CASSETTE RECEPTACLE 4. PEAK/VU INDICATOR LAMP 5. INDEX COUNTER AND RESET BUTTON 6. REPEAT BUTTON 7. MEMORY REWIND BUTTON 8. IPLS BUTTON 9. TIMER START SWITCH 10. TAPE SELECTOR AND TAPE POSITION 11. FL DISPLAY BAR METER 12. CAL TONE BUTTON AND INDICATOR LAMP 13. MPX FILTER SWITCH AND INDICATOR LAMP 14. DOLBY NR BUTTON AND INDICATOR LAMP 15. TAPE MONITOR BUTTON AND INDICATOR LAMP 16. OUTPUT LEVEL CONTROL 17. HEADPHONE JACK | <ol style="list-style-type: none"> 18. LEFT AND RIGHT MICROPHONE JACKS 19. LINE RECORDING LEVEL CONTROLS (LEFT AND RIGHT) 20. REC CAL ADJUSTERS (LEFT AND RIGHT) 21. MICROPHONE RECORDING LEVEL CONTROLS (LEFT AND RIGHT) 22. MODE BUTTONS 23. REC MUTE 24. REC CANCEL BUTTON 25. PEAK/VU BUTTON 26. LINE INPUT JACKS (LEFT AND RIGHT) 27. DIN JACKS (Some models not provided with this facility) 28. LINE OUTPUT JACK (LEFT AND RIGHT) 29. REMOTE CONTROL JACK 30. VOLTAGE SELECTOR (U/T, CEE, UK only) 31. AC INLET (U/T, CEE, UK only) |
|---|--|

IV. PRINCIPAL PARTS LOCATION

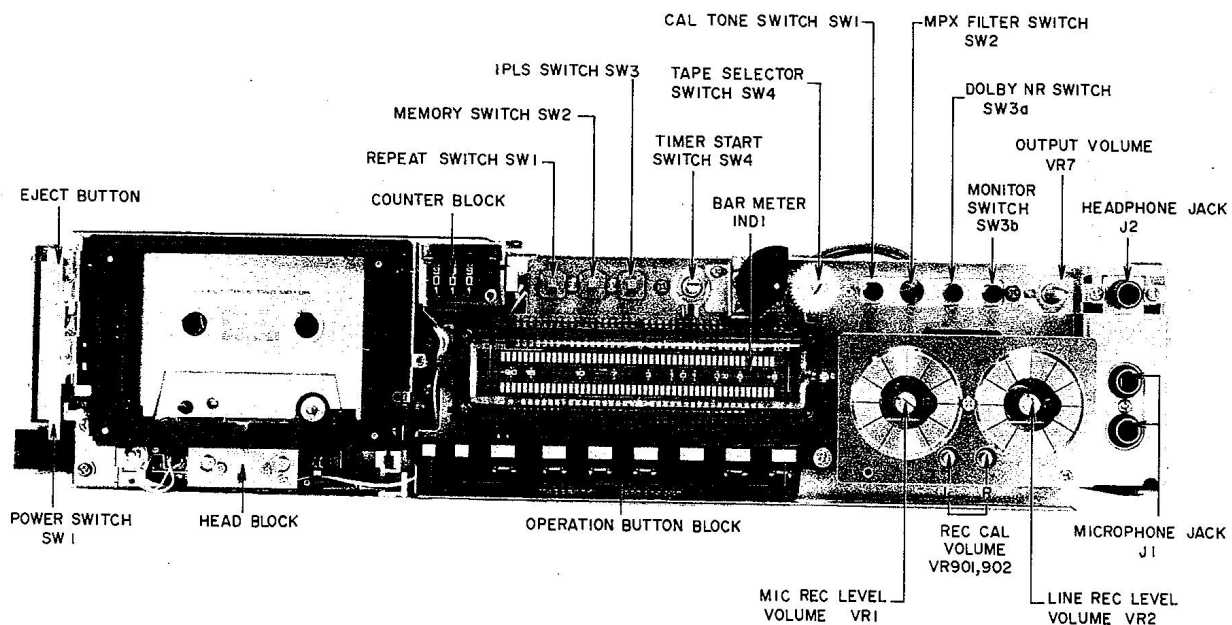

Fig. 2 Front View

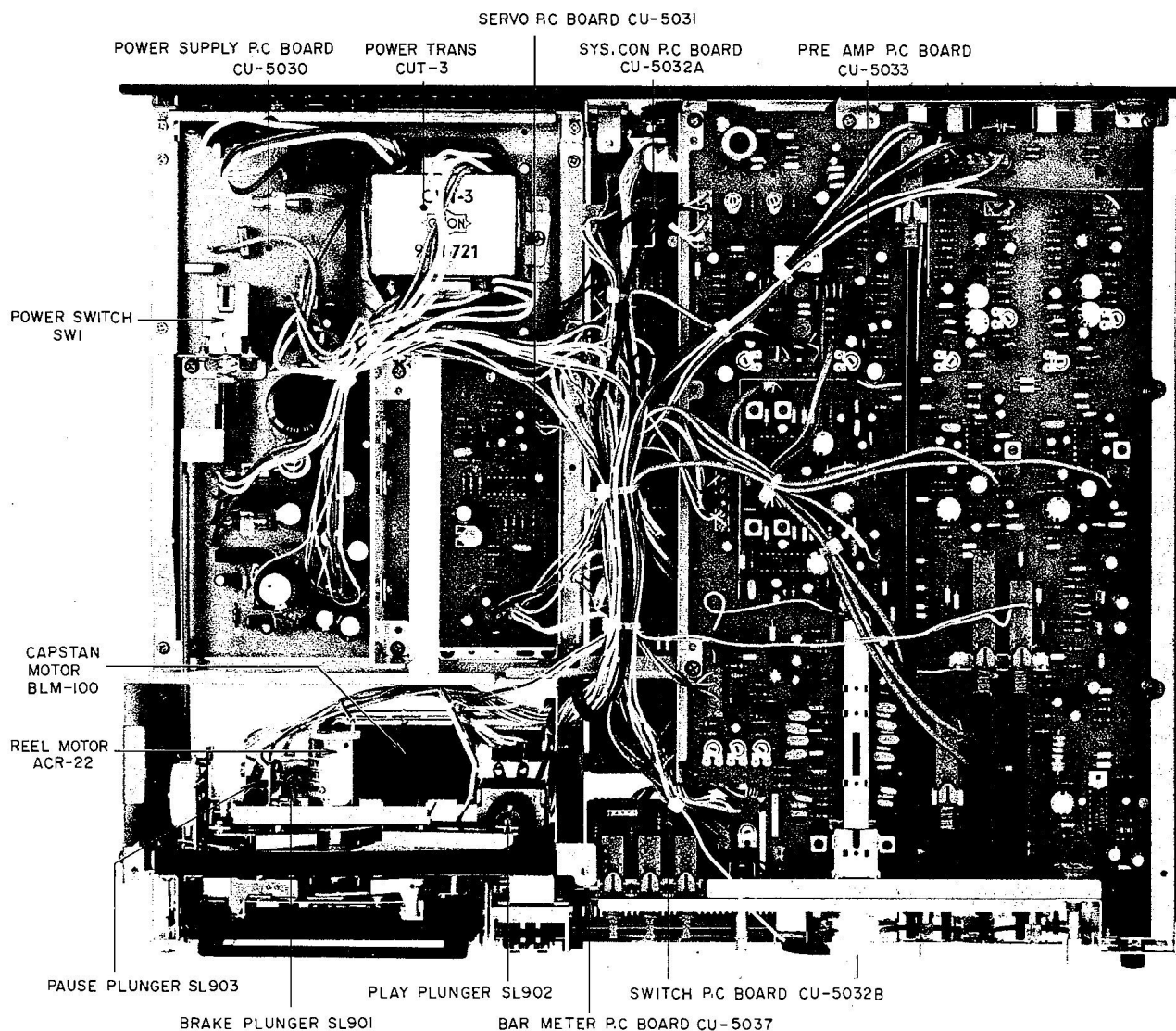

Fig. 3 Top View

V. VOLTAGE AND CYCLE CONVERSION

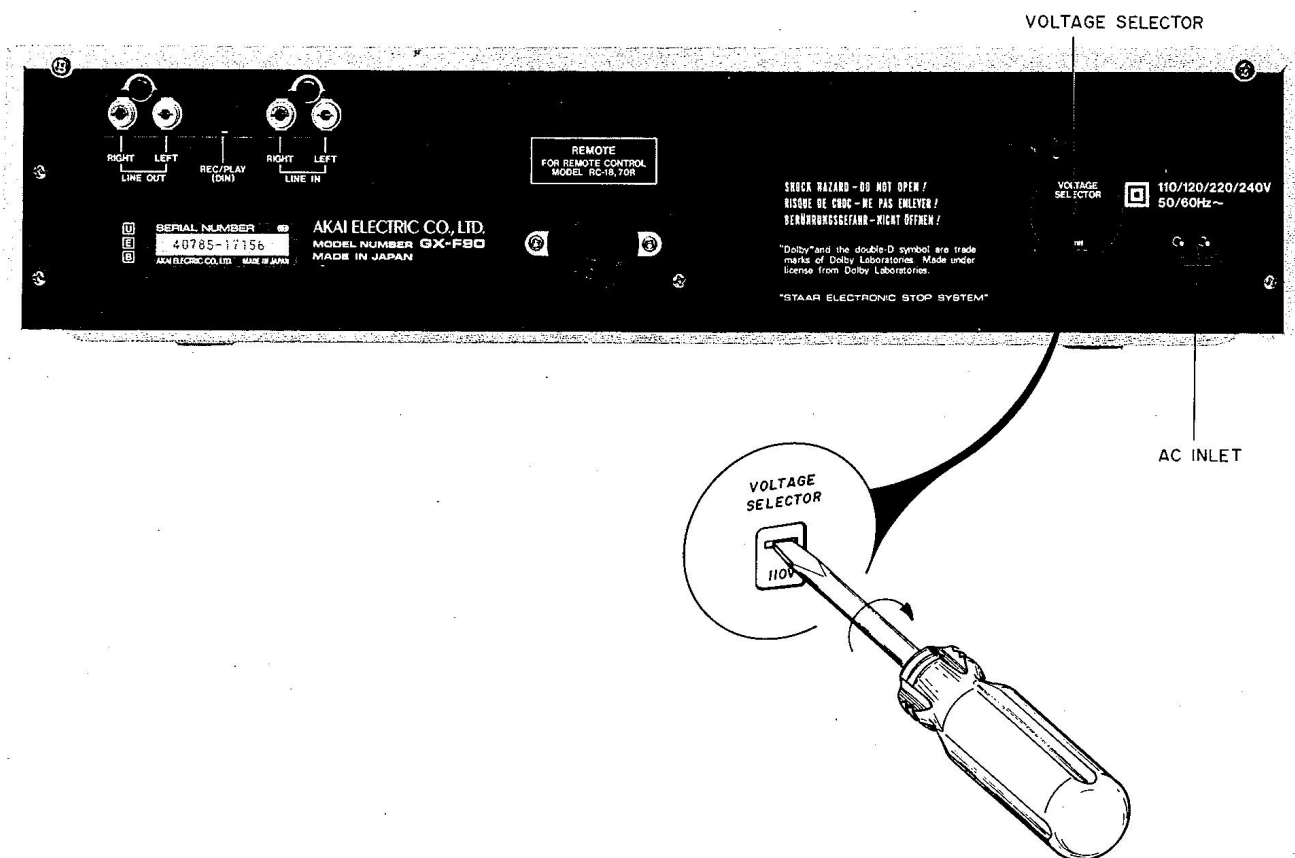

Fig. 4 Rear View (U/T, CEE, UK Models)

1. VOLTAGE CONVERSION

1) JPN, CSA, AAL Model

No voltage conversion.

2) U/T, CEE, UK Model (Refer to Fig. 4)

Turn the Voltage Selector on the rear panel to the right with a minus screwdriver, as shown in Fig. 4, to obtain 110V, 120V, 220V successively. All you have to do is match the voltage you want with the voltage indicated. Fuse change is not necessary.

CAUTION: When converting voltage turn off the power switch and unplug the power cord.

2. CYCLE CONVERSION

With DC motor cycle conversion is not necessary.

VI. CIRCUIT OPERATING PRINCIPLES

1. SYSTEM CONTROL OPERATION



NAND CIRCUIT	 $X = \overline{A \cdot B}$	<table border="1" data-bbox="994 250 1164 416"><thead><tr><th>A</th><th>B</th><th>X</th></tr></thead><tbody><tr><td>0</td><td>0</td><td>1</td></tr><tr><td>1</td><td>0</td><td>1</td></tr><tr><td>0</td><td>1</td><td>1</td></tr><tr><td>1</td><td>1</td><td>0</td></tr></tbody></table>	A	B	X	0	0	1	1	0	1	0	1	1	1	1	0
A	B	X															
0	0	1															
1	0	1															
0	1	1															
1	1	0															
OR CIRCUIT	 $X = A + B$	<table border="1" data-bbox="994 477 1164 642"><thead><tr><th>A</th><th>B</th><th>X</th></tr></thead><tbody><tr><td>0</td><td>0</td><td>0</td></tr><tr><td>1</td><td>0</td><td>1</td></tr><tr><td>0</td><td>1</td><td>1</td></tr><tr><td>1</td><td>1</td><td>1</td></tr></tbody></table>	A	B	X	0	0	0	1	0	1	0	1	1	1	1	1
A	B	X															
0	0	0															
1	0	1															
0	1	1															
1	1	1															
NOR CIRCUIT	 $X = \overline{A + B}$	<table border="1" data-bbox="994 703 1164 869"><thead><tr><th>A</th><th>B</th><th>X</th></tr></thead><tbody><tr><td>0</td><td>0</td><td>1</td></tr><tr><td>1</td><td>0</td><td>0</td></tr><tr><td>0</td><td>1</td><td>0</td></tr><tr><td>1</td><td>1</td><td>0</td></tr></tbody></table>	A	B	X	0	0	1	1	0	0	0	1	0	1	1	0
A	B	X															
0	0	1															
1	0	0															
0	1	0															
1	1	0															

Chart-1



Schematic-1 STOP MODE

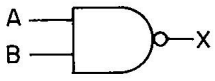

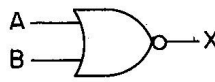
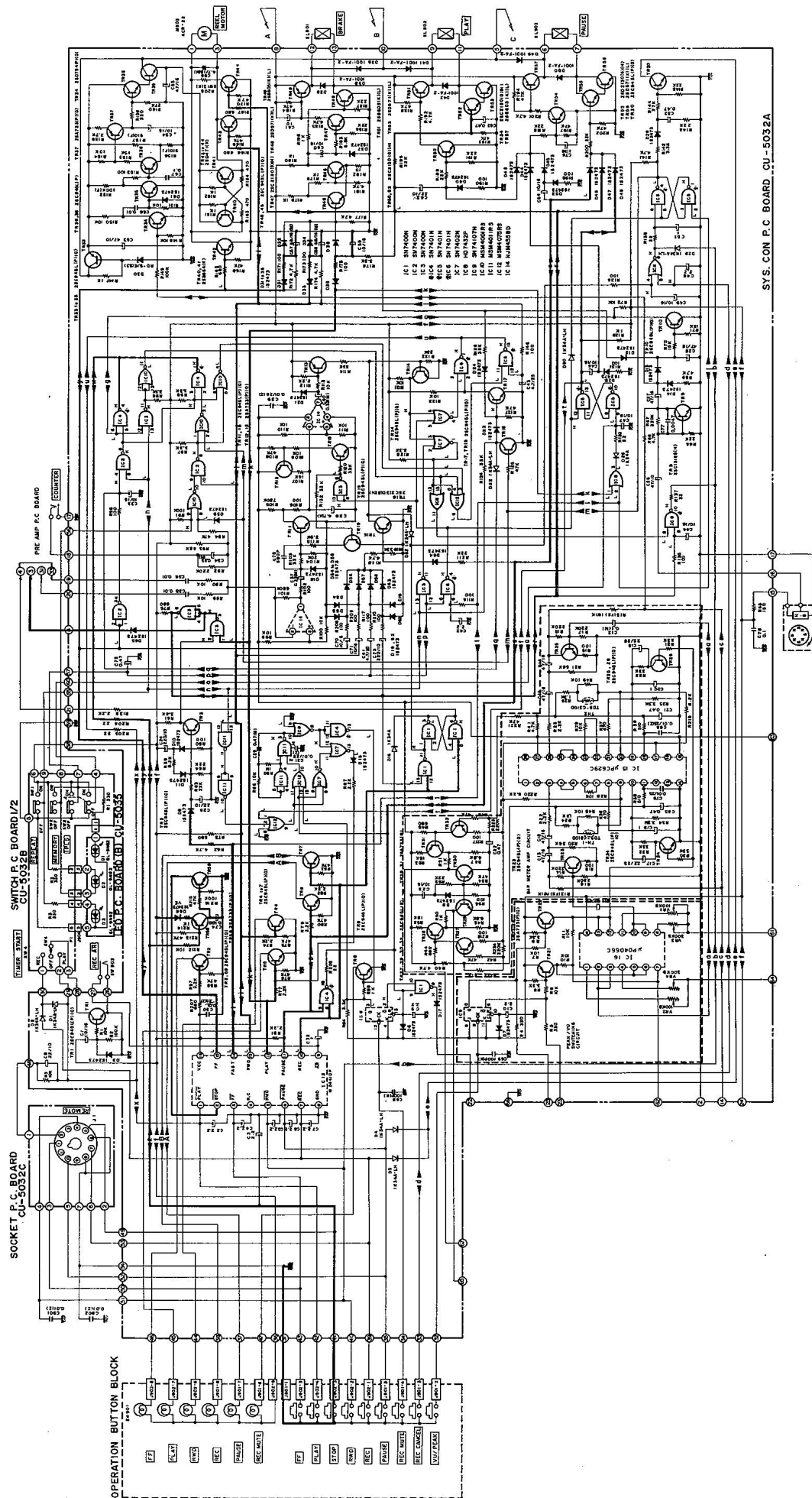
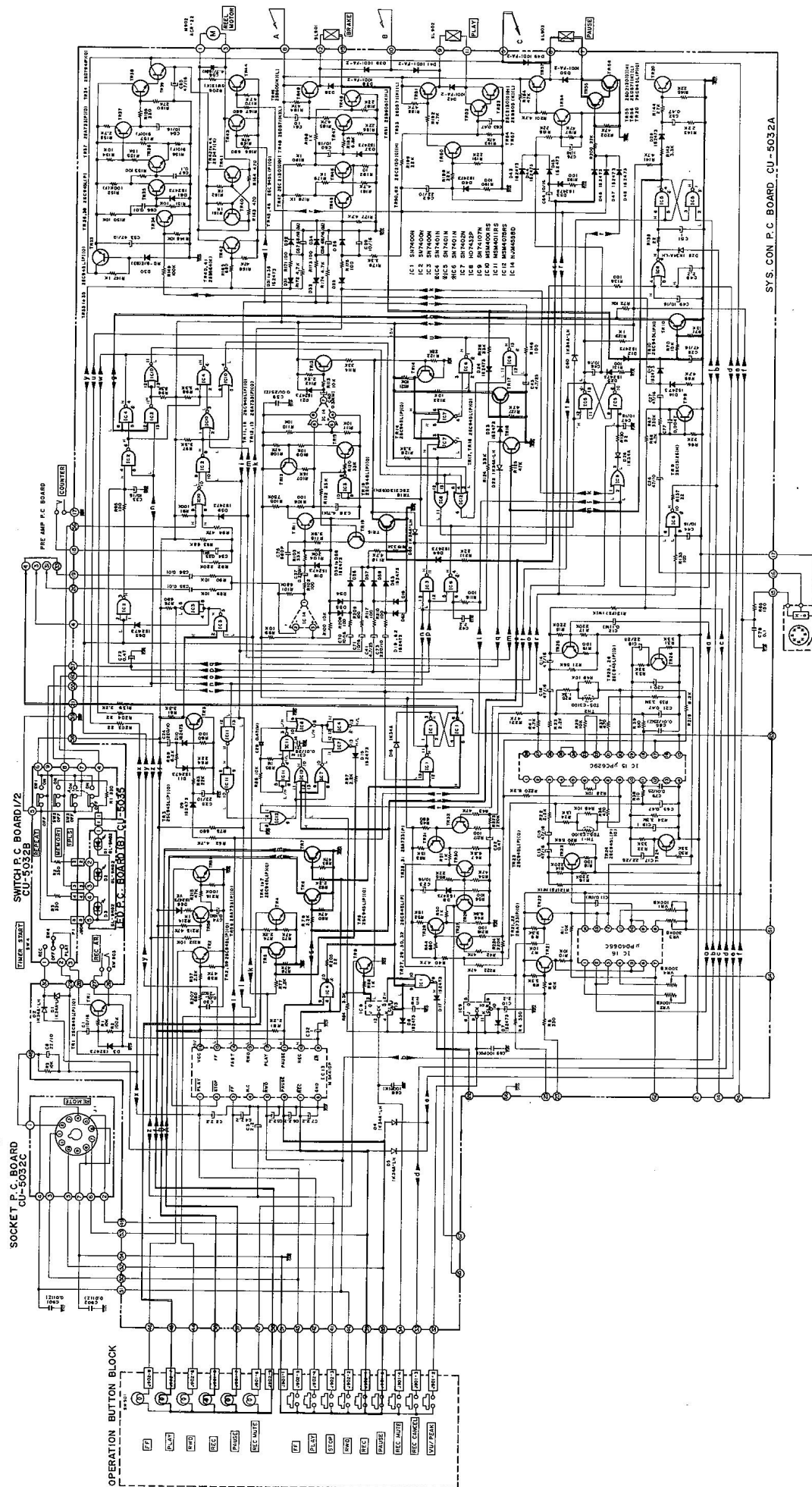
Schematic-4 REC/PAUSE MODE

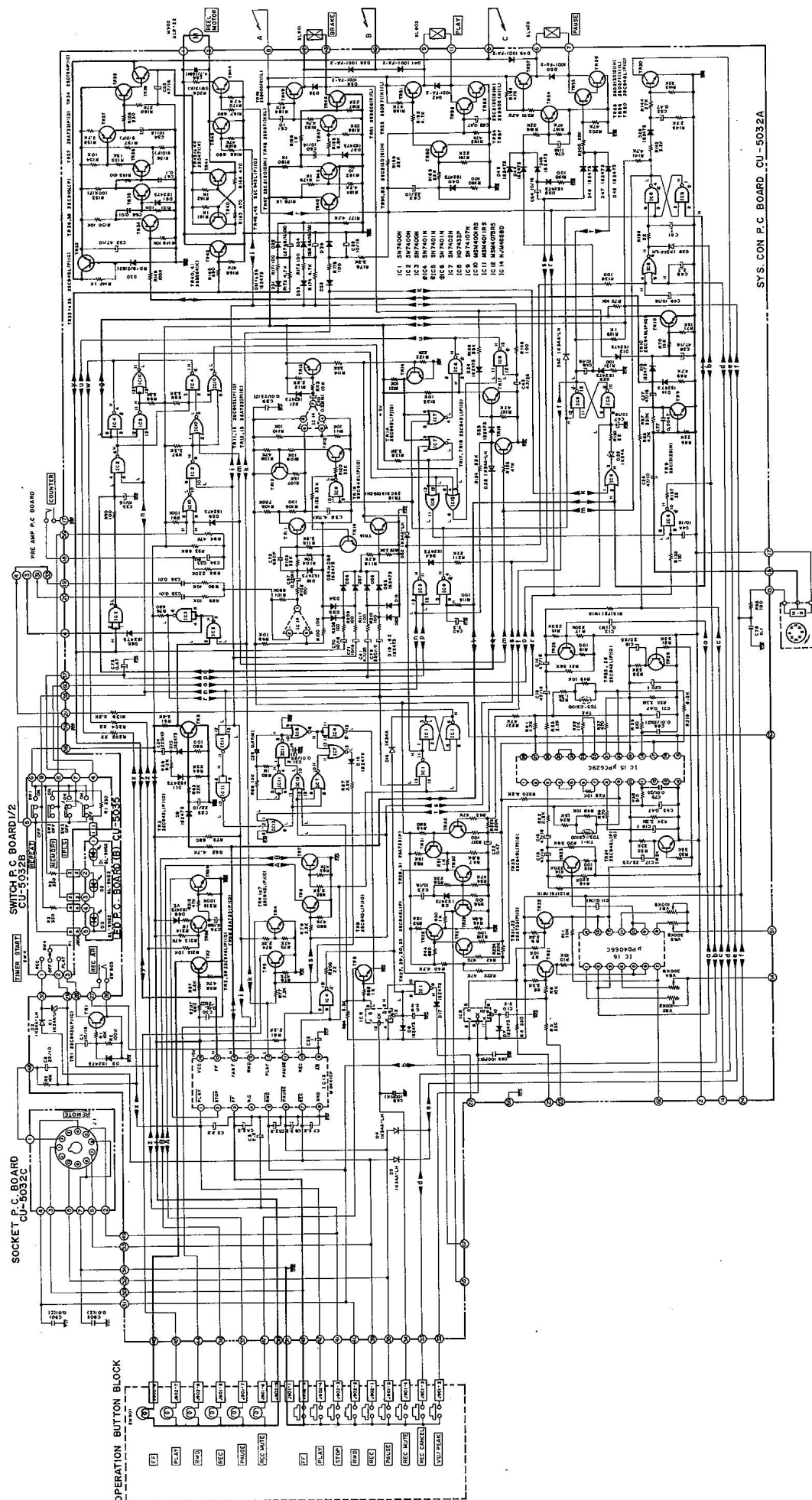

Schematic-5 FF MODE

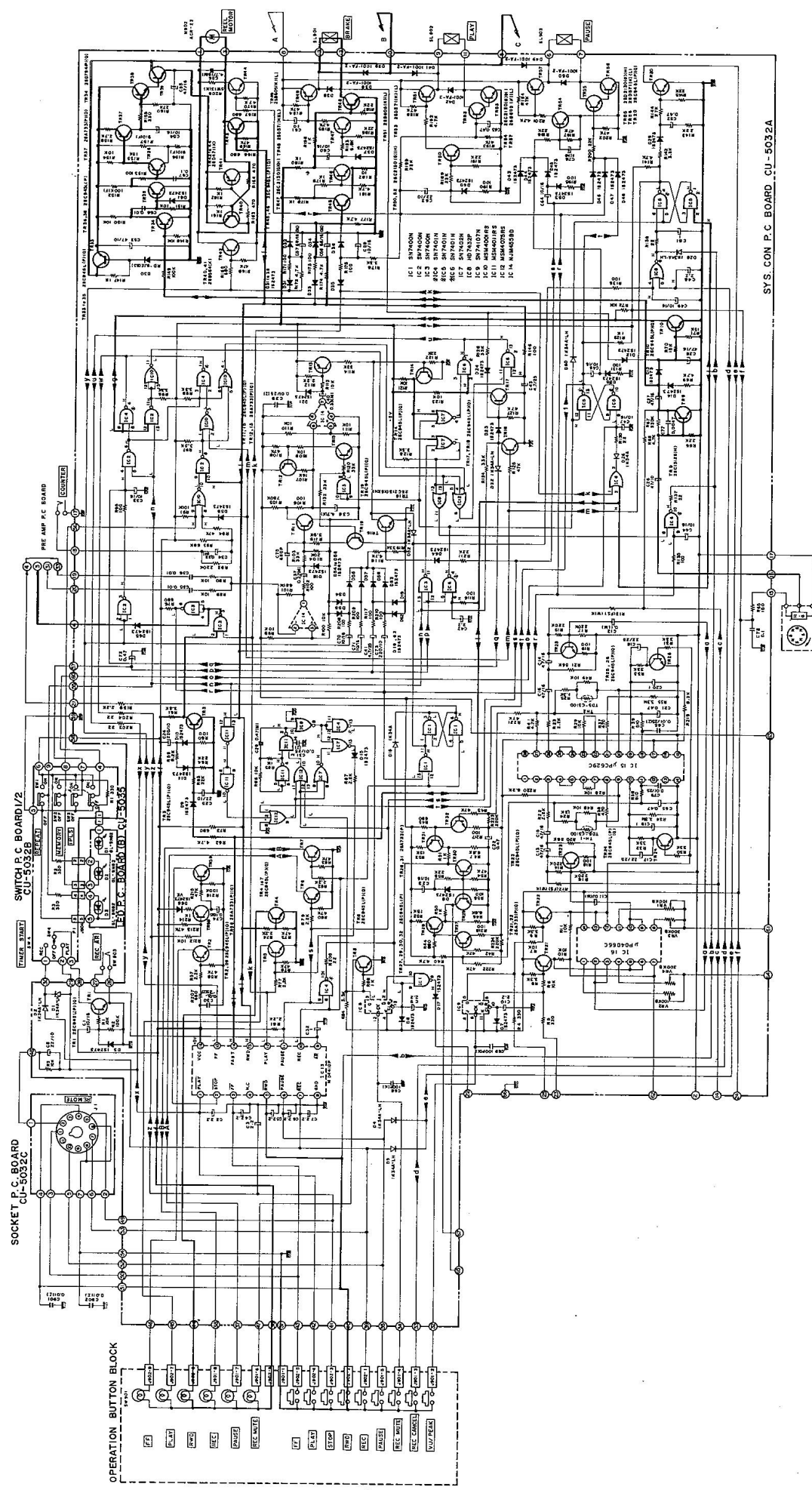

SYS. CON P.C. BOARD CU-5032A

Schematic-6 RWD MODE

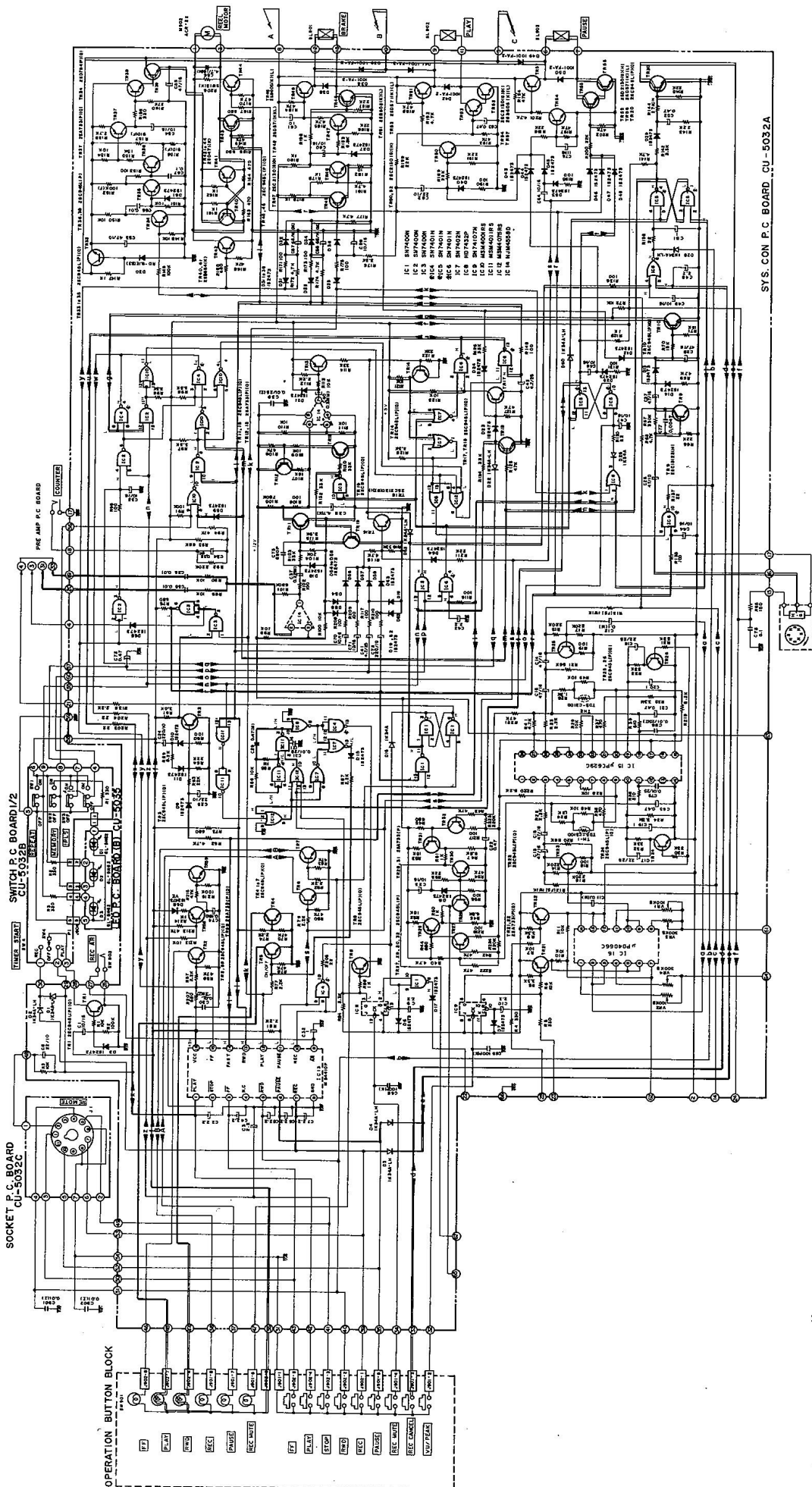

Schematic-10 REC CANCEL

1-1. CIRCUIT CONSTRUCTION OF IC1 M54410P

This logic IC has been developed for an operation key that will maintain a HIGH output level by even a momentary low level in the desired input terminal.

1) Block Diagram

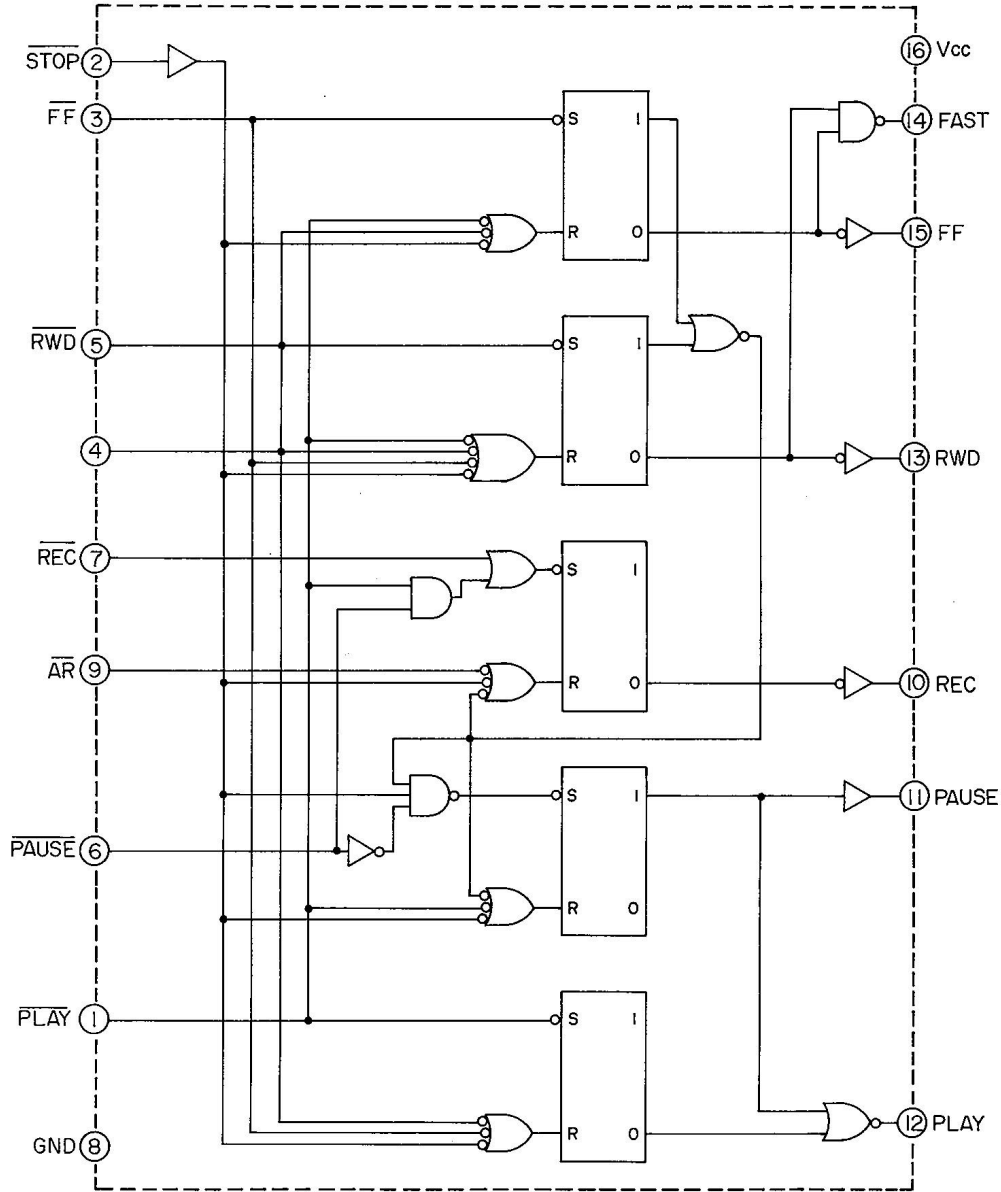

Fig. 5 M54410P

2) Terminals and their functions

	Terminal Name	Terminal Function
Operation input terminals	$\overline{\text{STOP}}$	Input terminal for stopping operation
	$\overline{\text{FF}}$	Input terminal for fast forward
	$\overline{\text{RWD}}$	Input terminal for rewind
	$\overline{\text{REC}}$	Input terminal for recording
	$\overline{\text{PAUSE}}$	Input terminal for pause
	$\overline{\text{PLAY}}$	Input terminal for playback
Control input terminal $\overline{\text{AR}}$		Input terminal for preventing recording
Output terminals	FAST	Terminal with "H" signal output during fast forward or rewind mode
	FF	Terminal with "H" signal output during fast forward mode
	RWD	Terminal with "H" signal output during rewind mode
	REC	Terminal with "H" signal output during REC/PLAY or REC/PAUSE mode
	PAUSE	Terminal with "H" signal output during pause mode
	PLAY	Terminal with "H" signal output during playback mode

Chart-2

3) Operation activated by each input

Input Signal	Output						Output Mode
	FAST	FF	RWD	REC	PAUSE	PLAY	
$\overline{\text{STOP}}$	L	L	L	L	L	L	STOP Mode
$\overline{\text{FF}}$	H	H	L	L	L	L	FF Mode
$\overline{\text{RWD}}$	H	L	H	L	L	L	RWD Mode
$\overline{\text{PLAY}}$	L	L	L	L	L	H	PLAY Mode
$\overline{\text{PAUSE}}$	L	L	L	L	H	L	PAUSE Mode
$\overline{\text{REC/PLAY}}$	L	L	L	H	L	H	REC/PLAY Mode
$\overline{\text{REC/PAUSE}}$	L	L	L	H	H	L	REC/PAUSE Mode

Chart-3

- NOTES:**
1. The input signal is activated by the fall of $\overline{\square}$.
 2. The output is maintained until the next input signal.
 3. $\overline{\text{AR}}$ is a control input terminal and the REC output is not "H" when $\overline{\text{AR}} = \text{"L"}$.
 4. When $\overline{\text{AR}} = \text{"L"}$ signal is supplied during the REC output is "H", REC output becomes "L".
 5. At the moment the power is on, all output will be "L" and the Stop mode will be effected.

1-2. TRANSISTOR AND PLUNGER ACTUATED FOR EACH OPERATION

(Refer to Sys. Con Schematic Diagram)

	TR53	TR51	PLAY PLUNGER	TR48	TR49	BRAKE PLUNGER	TR56	TR57	PAUSE PLUNGER	1 SEC OSC	BIAS OSC
PLAY	○	△	○	○	△	○	○	△	○		
PLAY/PAUSE							○	△	○	○	
REC/PLAY	○	△	○	○	△	○	○	△	○		○
REC/PAUSE							○	△	○	○	○
FF				○	△	○					
RWD				○	△	○					
RWD (IPLS ON)				○	△	○	○	△	○	○	

○: Operating △: Momentary Operation

Chart-4

1-3. REPEAT PLAYBACK CIRCUITRY OPERATION EXPLANATION

(Refer to Schematic-7)

- 1) With repeat playback, the tape is automatically rewound to the beginning and played back when the tape end is reached, if the Repeat button has been depressed during playback (or recording).
- 2) First at the end of the tape, when the mode changes from PLAY to RWD, when the revolution switch is stopped, IC6-⑧ becomes High Level so IC6-⑩ becomes Low Level and it goes into the RWD mode. Next at the beginning of the tape as it changes from RWD to PLAY, when the revolution switch stops, IC6-⑪ becomes High Level, so IC6-⑬ becomes Low Level and it enters the PLAY mode.
- 3) Circuitry operation in order.
After the Repeat switch has been depressed, when put into the PLAY mode, the circuitry operates as in Schematic-7.

In the play mode, the revolution switch turns so TR10 is turned ON. This time, IC2-⑫ is Low Level so IC10-⑪ is Low Level.

As a result, IC8-⑫, ⑬ and IC12-③, ④, ⑤ are all Low Level so IC8-⑪, IC12-⑥ are Low Level. In the PLAY mode, IC6-⑨ is High Level. At the end of the tape when the revolution switch stops TR10 is turned OFF, IC2-⑫ changes to High Level, IC2-⑪ to Low Level, IC10-⑪ to High Level, IC8-⑪ to High Level and IC6-⑩ to Low Level. As a result, IC13-⑤ (RWD) becomes Low Level and moves from the PLAY mode to RWD. In the RWD mode, IC6-⑫ is High Level and IC12-③, ④, ⑤ are all Low Level because the revolution switch is revolving just as in the PLAY mode so IC12-⑥ is Low Level.

When the tape returns to the beginning and the revolution switch stops, IC12-④ becomes High Level so IC12-⑥ changes to Low Level, and IC6-⑬ to Low Level. As a result, IC13-① (PLAY) becomes Low Level, and the mode changes from RWD mode to PLAY mode.

As outlined above the deck changes to PLAY or RWD modes according to the levels of IC8-⑪ and IC12-⑥.

1-4. IPLS CIRCUITRY EXPLANATION

(Refer to Fig. 6 and Schematic-8)

- 1) With the IPLS operation (Instant Program Locating System) after the IPLS switch has been depressed when the FF or RWD key is depressed, the no signal portion between music is detected and so the beginning of desired selection is reached, playback begins automatically.
- 2) Explanation of circuitry detecting the no-signal portion between songs (See Fig. 6). When the FF or RWD key is depressed with the IPLS switch depressed, the PAUSE plunger is activated, and the head contacts the tape. The signal with Lch and Rch mixed enters to the IC14-a ② terminal. After being amplified by IC14-a, it is positive clamped by C37 and D18 and added to TR11's base as bias. When TR10 is ON, IC14-b ⑥ terminal becomes almost earth potential so at terminal ⑦ voltage of +12V appears. As a result TR13 goes OFF.
- 3) When a no-signal portion is reached, the bias disappears in TR11's base, C38 is charged and IC14-b's ⑥ terminal potential is raised. Thus, as IC14-b's ⑦ terminal potential is lowered, charging current flows to C40. As result, TR13's

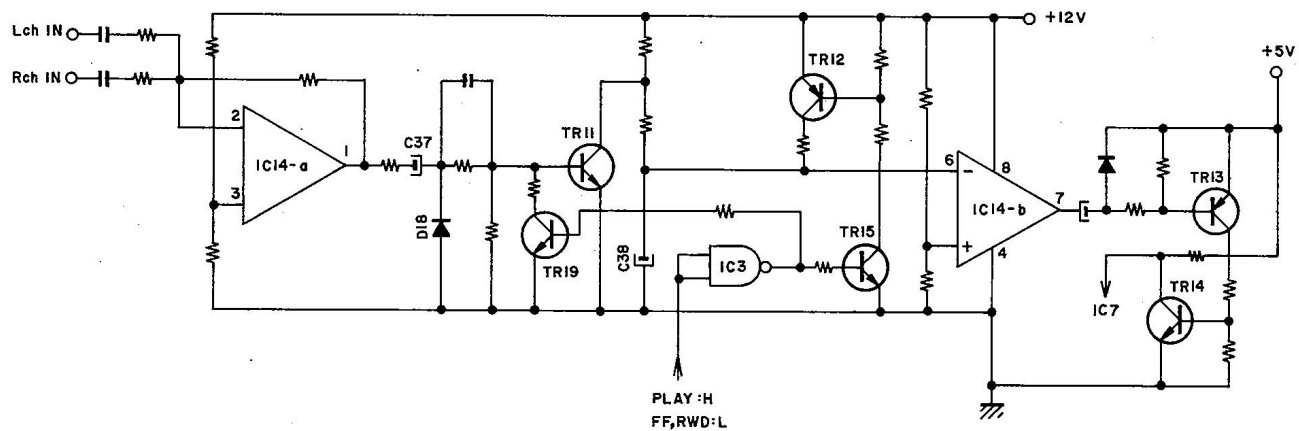

Fig. 6

base potential drops and TR13 goes ON. When TR13 goes ON, TR14 goes ON as potential is added to the TR14's base and the input of IC7, which is connected to the collector of TR14, becomes Low Level.

- 4) When both the IPLS and repeat switches have been depressed simultaneously, it must detect the no-signal portion in the play mode. At this time, TR19, TR15 and TR12 are put to OFF to raise the sensitivity because the musical signal entering IC14-a ② terminal is low compared with the signal in FF and RWD.

- 5) Explanation of the full circuitry.

When put in the RWD mode (applies equally to FF mode) after the IPLS switch has been depressed, the circuitry operation is as in schematic-8. At this time, IC5-⑬ becomes High Level so the PAUSE plunger is activated. Again in IC14-② terminal, TR14 goes off due to the signal being input. As a result, IC7-⑥ becomes High Level so when the no-signal portion comes, TR14 turns ON as explained above. Then, IC7-⑥ becomes Low Level, IC7-④ changes to High Level and IC6-① to Low Level and IC13-① (PLAY) becomes Low Level and it changes to the PLAY mode.

When it changes to the PLAY mode, IC7-⑤ is fixed at High Level so the PLAY mode does not change even when no-signal portion comes.

1-5 CIRCUITRY FOR REPEAT PLAYBACK OF ONE MUSIC ONLY (Refer to Schematic-9)

- 1) With this circuitry, when the one music comes which you want to listen to repeatedly, both the IPLS and Repeat switches are depressed. Then it detects the blank portion at the end of the song in the PLAY mode, switches to RWD mode, and

rewinds back to the beginning of the song and moves automatically into the PLAY mode.

This construction repeats this operation.

- 2) How the circuitry operates with both the IPLS and REPEAT switches depressed. See Schematic-9 as to how the circuitry operates when both the IPLS and REPEAT switches have been depressed in the PLAY mode. At this time a music signal is being input into IC14-② so the input compared with when IPLS operates alone is low.

As a result, IC13-⑧ becomes Low Level so TR19, TR15 and TR12 are turned off and the sensitivity of the no signal portion detector during playback is increased. A signal is input into IC14-② during the music, switching TR14 OFF (Refer to IPLS operation explanation). Then as IC7-③ is High Level both IC8-⑫, ⑬ are Low Level.

When the music comes to an end, when the signal stops being input into IC14-②, TR14 is switched on and IC7-③ changes to Low Level. Then, IC7-① changes to High Level, then IC8-⑫ to High Level, IC8-⑪ to High Level and finally both IC6-⑧, ⑨ become High Level. As a result, IC6-⑩ becomes Low Level, IC13-⑤ (RWD) Low Level and the deck moves into rewind. When it moves to RWD mode, IC6-⑫ is fixed at High Level and IC6-⑨ at Low Level. Now when the no signal portion at the beginning of the music is reached, TR14 turns ON and IC7-③ changes to Low Level.

Then, IC7-① changes to High Level, then IC12-⑤ to High Level, IC12-⑥ to High Level and finally both IC6-⑪ and ⑫ become High Level. As a result, IC6-⑬ becomes Low Level and then IC13-① (PLAY) becomes Low Level so the deck moves into the Play mode. The above operation is repeated so that playback of only one music repeatedly is possible.

1-6. REC CANCEL CIRCUITRY OPERATION

EXPLANATION (Refer to Schematic-3, 10)

1) With the REC CANCEL, when the REC CANCEL button is depressed during the REC mode, the tape is rewound to the beginning of the program being recorded, detects the no-signal portion and then automatically puts the deck into the REC/PAUSE mode.

2) Simple flow explanation.

Firstly, when the REC CANCEL button is depressed in the REC mode, IC13 ($\overline{\text{RWD}}$) becomes Low Level, and the mode changes into the $\overline{\text{RWD}}$ mode. At this time, TR20 turns ON, and drops the IC13 $\overline{\text{REC}}$, $\overline{\text{PAUSE}}$ inputs to earth potential. When the no-signal period at the beginning of the program comes the $\overline{\text{PLAY}}$ becomes Low Level and RWD is released. Because $\overline{\text{REC}}$, $\overline{\text{PAUSE}}$ have dropped to earth potential, it does not go into the play mode and instead becomes REC/PAUSE. IC13 (M54410P) maintains the RWD mode even when $\overline{\text{REC}}$, $\overline{\text{PAUSE}}$ are input during the $\overline{\text{RWD}}$ mode. As a result by being input into the $\overline{\text{PLAY}}$ mode, and releasing the RWD mode, to put into the REC/PAUSE mode.

3) Circuit explanation in order.

Refer to Schematic-3 for REC mode operation. When the REC Cancel button is depressed, both IC8-④, ⑤ become Low Level so IC8-⑥ also changes to Low Level. Then by passing D28, IC13-⑤ (RWD) becomes Low Level so there is a shift from the REC mode to the RWD mode. The Flip Flop output is reversed because IC5-⑥ becomes Low Level and then IC5-④ becomes High Level. As a result bias is added to TR20's base so TR20 goes on and by passing D4 and D5, IC13-⑥ (PAUSE) and ⑦ (REC) drop to earth potential.

At the same time, as IC5-① has become Low Level, IC5-⑬ becomes High Level, the Pause Plunger is activated and the recorded program signal is input into IC14-②. See Schematic-10. While the signal is being input into IC14-②, TR14 goes off as it does in the IPLS explanation. As a result, IC7-⑥ is High Level and IC7-④ becomes Low Level and IC6-① High Level.

Also at this time, IC7-⑤ is Low Level.

When the no-signal portion at the beginning of the recorded program is reached, TR14 switches ON so IC6-② and IC7-⑥ change to Low Level. Then as IC7-④ becomes High Level, both IC6-② and ③ become High Level and then IC6-① changes to Low Level.

Next, IC13-① (PLAY) becomes Low Level and the RWD mode is released. It changed to the REC/PAUSE mode and not Play because IC13-⑥ (PAUSE) and ⑦ (REC) are at earth potential.

1-7. THE OSCILLATOR CIRCUITRY FOR TURNING THE PLAY, REC OR REC MUTE INDICATORS ON AND OFF

1) This circuitry flashes the PLAY or REC MUTE indicators on and off at intervals of approximately 1 second. The play indicator flashes during IPLS's FF or RWD mode and Repeat, Rec Cancel's RWD mode and also Pause mode. The REC MUTE indicator flashes during REC MUTE.

2) In mode other than those stated above, as shown in Fig. 7, IC12-⑩ is Low Level, so IC11-③ is High Level. Then, charging current flows through R85 to C29. At this time, due to R85's voltage drop IC11-⑤, ⑥ become High Level and IC11-④ becomes Low Level. However, when C29 finishes charging, R85's voltage drop disappears and IC11-⑤, ⑥ become Low Level and IC11-④ High Level. It then stabilizes.

3) If in the above modes, to one of IC12-⑪, ⑫, ⑬ is input the High Level so IC11-② becomes High Level. Then as IC11-③ changes to Low Level, charging current flows through R85 to C29 as shown by the solid line in Fig. 8. During the charging period, (C29 and R85's fixed time constants) IC11-⑤ and ⑥ are kept at High Level but once charging has finished the voltage drop becomes 0 and IC11-⑤, ⑥ changed to High Level. When IC11-⑤, ⑥ change to High Level, IC11-④ changes to Low Level, and IC11-③ changes to High Level and now the charging current flows to C29 as shown by the dotted line. During the charging period, IC11-⑤, ⑥ are kept at high Level due to the R85's voltage drop, but when the voltage drop becomes 0, IC11-⑤, ⑥ change to Low Level and IC11-④ to High Level and IC11-③ to Low Level and again the charging current flows as shown by the solid line. As this operation is repeated, square waves of approximately 1 Hz are input into IC8-⑩ and the same kind of wave form appears in IC8-⑧.

4) When the PLAY indicator lamp flashes on and off IC7-⑪ is fixed at Low Level so as the square waves of 1 Hz input into IC7-⑫, they are reversed and appear in IC7-⑬. This output, passing through D15 and R87 is added as bias of TR5 and the PLAY indicator lamp flashes. REC MUTE will be explained in 1-8.

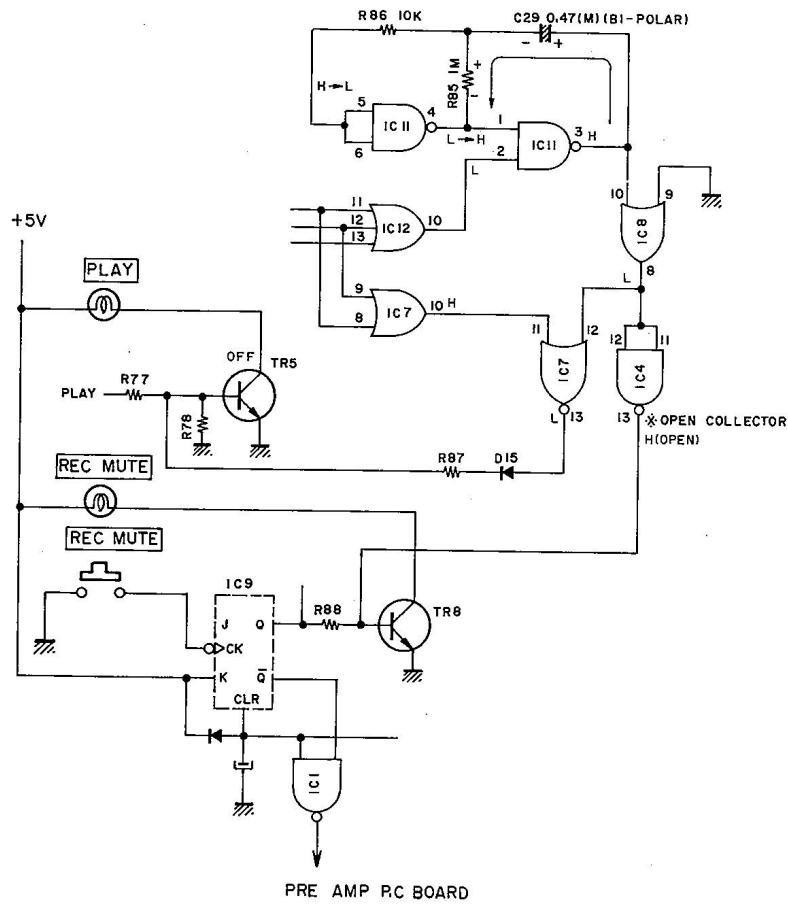

Fig. 7 Oscillation stopped

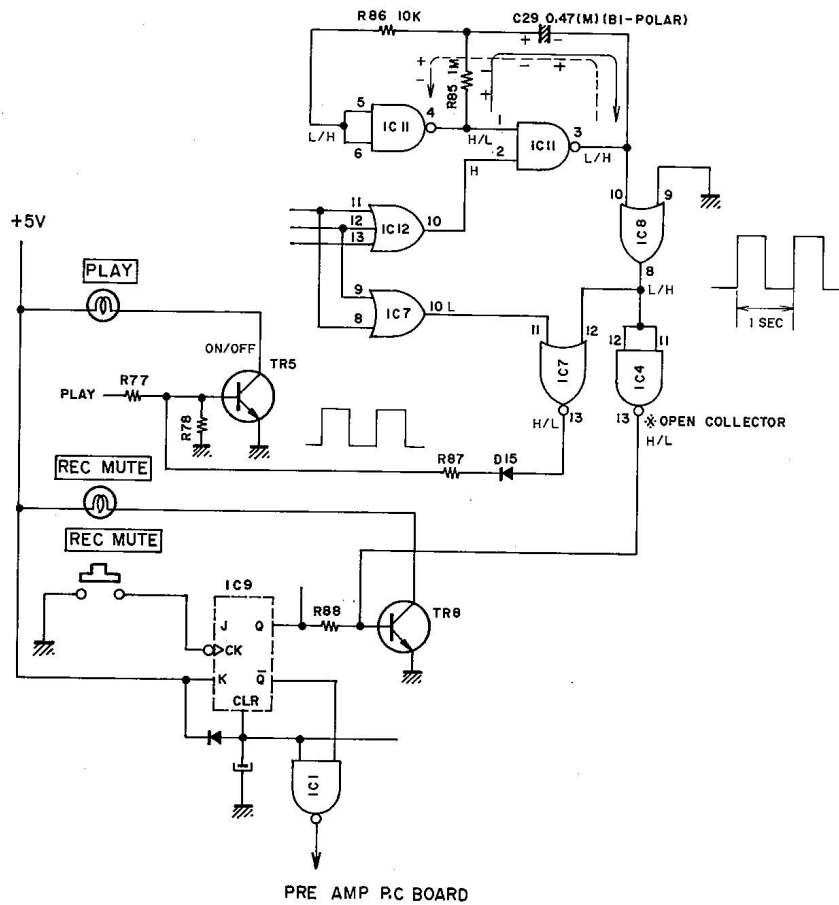

Fig. 8 Oscillation

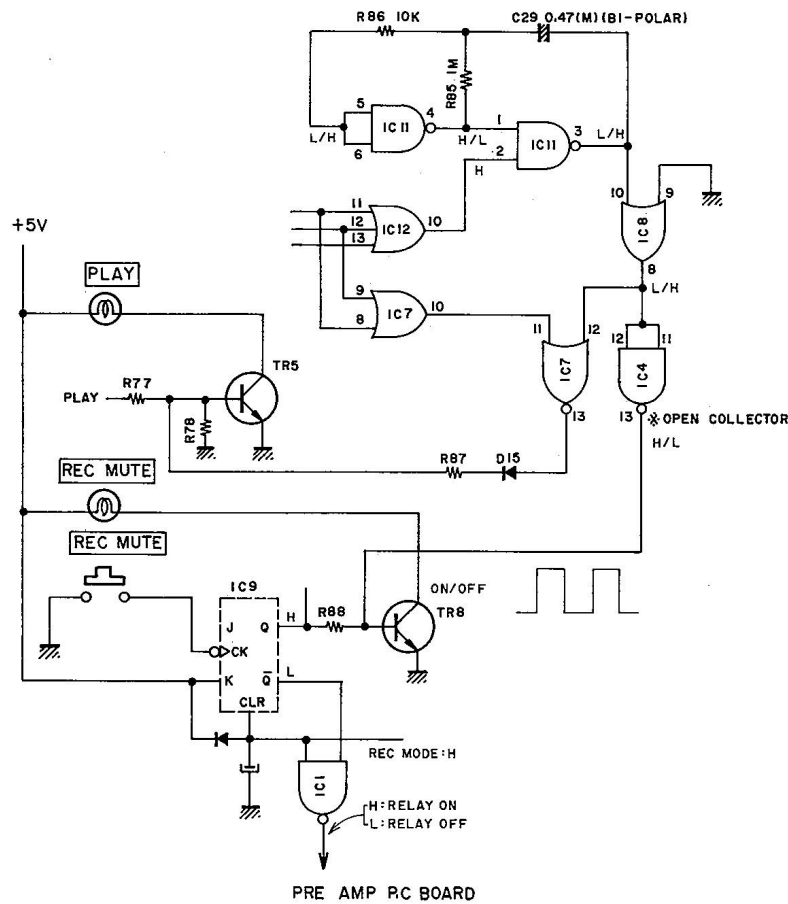

Fig. 9

CLR	CK	J	K	Q	\bar{Q}
L	X	X	X	L	H
H		L	L	UNCHANGABLE	
H		H	L	H	L
H		L	H	L	H
H		H	H	INVERSION	

Chart-5

1-8 REC MUTE CIRCUITRY USING

JK-FLIP FLOP (Refer to Chart-5 and Fig. 9)

1) Chart-5 shows the truth table for JK-Flip Flop. As in this case, when J and K terminals are kept at High Level, Q, \bar{Q} output is reversed when everytime there is CK input. Also when CLR becomes Low Level, Q is fixed at Low Level and \bar{Q} is fixed at High Level.

2) As CLR is Low Level, Q: Low Level, \bar{Q} : High Level in all modes other than REC mode. In the REC mode, CLR becomes High Level but Q and \bar{Q} do not change as there is no CK input. Also as both IC1-⑨, ⑩ have become High Level, IC1-⑧ becomes Low Level, the Pre Amp P.C Board relay works and the recording signal flows to the head. If the Rec Mute button is depressed here, Q and \bar{Q} are reversed so that Q: High Level and \bar{Q} : Low Level.

Then IC1-⑩ becomes Low Level, in High Level appears in IC1-⑧ the relay is switched OFF and the recording signal does not flow to the head. Also TR8 goes on because High Level appears in Q. However, square waves are added to TR8's base at one second intervals so TR8 is OFF when there is square wave earth potential.

Due to this, the REC Mute indicator light begins to flash ON and OFF. The light does not flash ON and OFF when the REC Mute is not working (when Q: Low Level) because IC4-⑬ has become an open collector and TR8 is usually OFF.

3) When the REC MUTE button is depressed again, REC MUTE is released because Q, \bar{Q} are reversed.

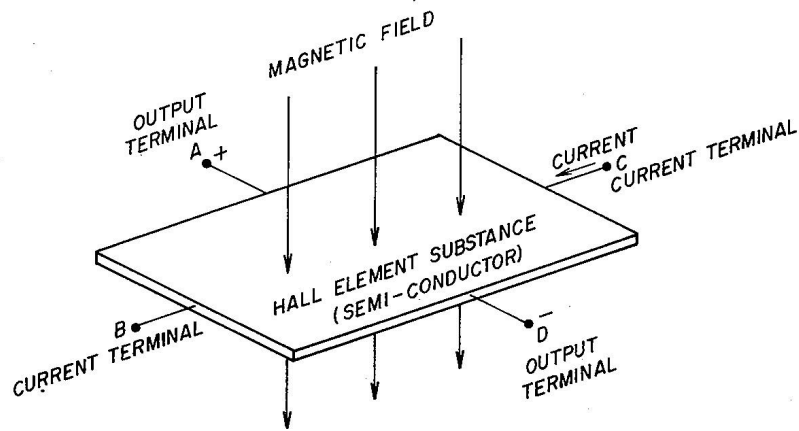

Fig. 10

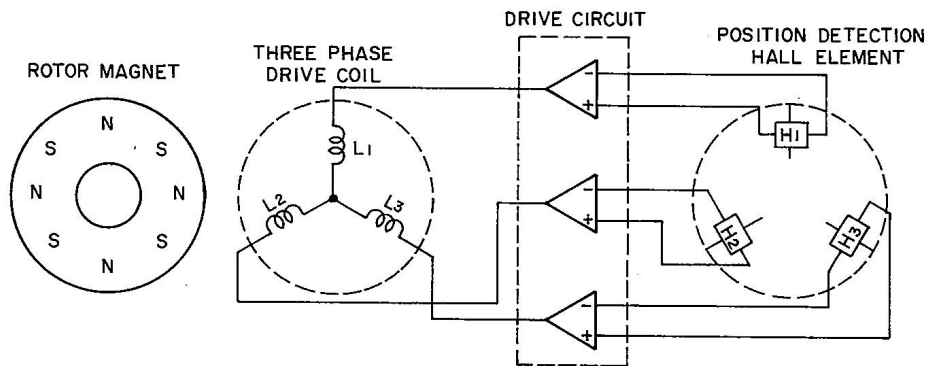

Fig. 11

2. EXPLANATION OF OPERATION OF DC BRUSHLESS DD CAPSTAN MOTOR (BLM-100)

2-1. MOTOR DRIVE CIRCUITRY

1) The recently developed Capstan Motor BLM-100 uses Hall elements in detecting the position of the magnetic polarities of the rotor magnets. There now follows a simple explanation of the theory behind the operation of these elements. The Hall element is a very thin plate of a semi-conductor and when magnetic fields are added at right angles to the surface, the elements generate voltage at

right angle to the currents which directly flow to the Hall elements and magnetic field, due to the magnetic force known as Lorenz force. The output voltage changes according to the strength of the magnetic field and controls with the flowing current.

2) Explanation of the principle of motor operation. As shown in Fig. 11, against the 8 poles of rotor magnet, 3 phase-driven-coils L1, L2 and L3, placed at electrical angle of 120° to each other, are connected to the Hall elements output terminals through their respective drive circuits.

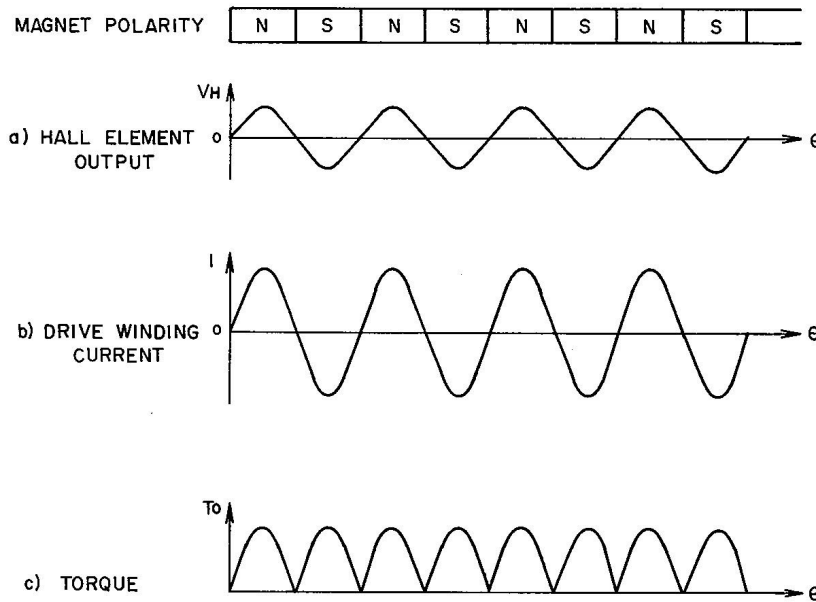

Fig. 12

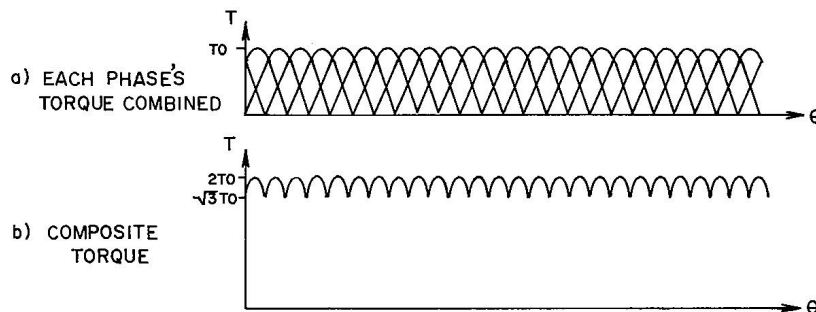

Fig. 13

Each Hall element H1, H2, and H3 is a detector that detects position of the magnetic poles of the rotor magnet and is placed at electrical angle of 120° to each other. Fig. 12 (a) and (b) show the Hall element output V_H and the drive coil's electrical current I , at one phase of one of the coils against the position of the magnetic poles in the rotor magnet when electricity is allowed to flow

into the motor. At this time, the torque created by one phase of one of the coils is the wave form shown in Fig. 12 (c).

Fig. 13 shows the torque wave forms for all three phases of the three drive coils. As shown, even when the motor's torque ripple is decreased there is a smooth rotation.

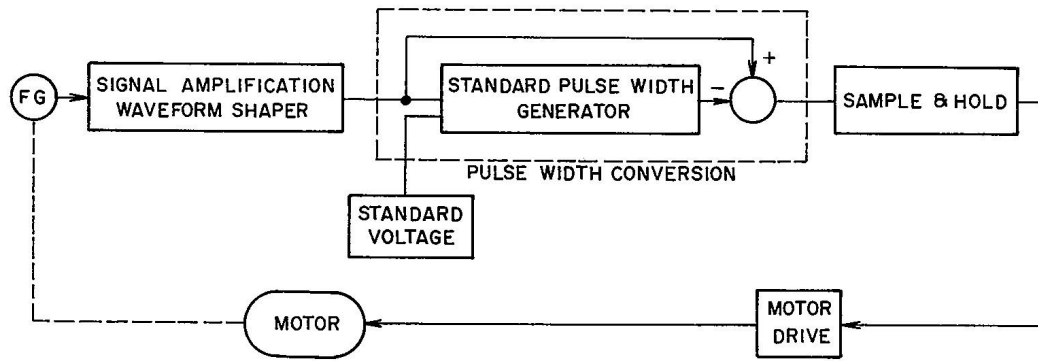

Fig. 14 Servo Circuit Block Diagram

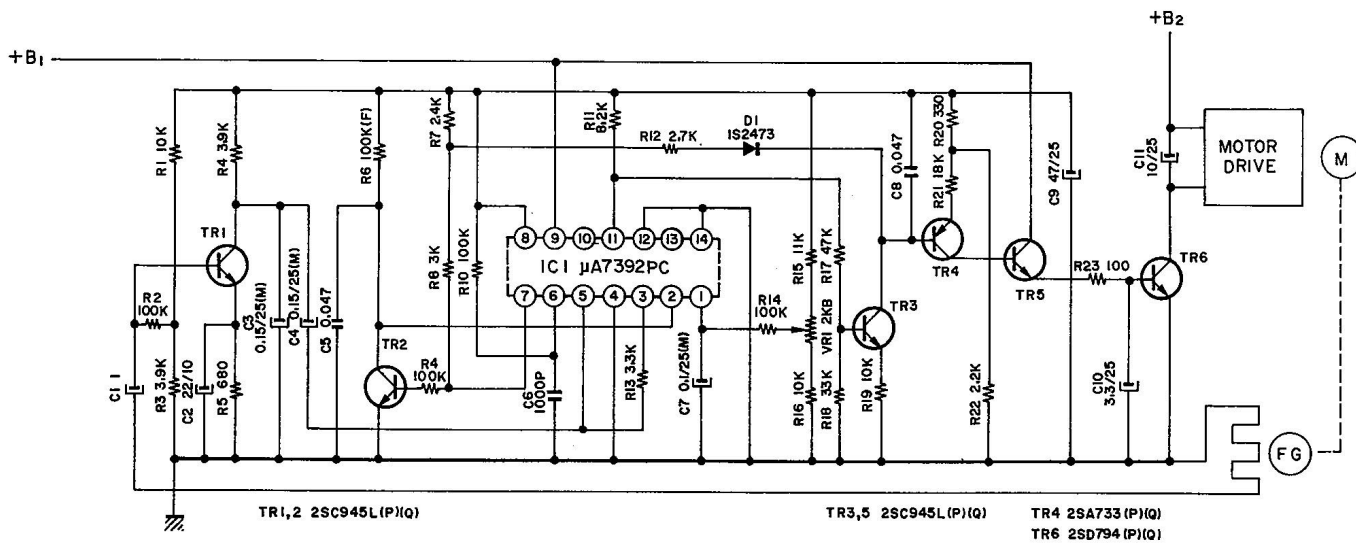

Fig. 15 Servo Circuit

2-2. SERVO CIRCUIT (Refer to Figs. 14 to 16)

The speed signal from the print coil appears as a wave form, shown in (a) at TR1 collector and is input into terminals ③ and ⑤ of IC1.

When the wave form (a) passes the threshold level at IC1, t_1 standardized, standard pulse is created, as shown in (b) and appears in IC1-⑦.

During this t_1 period, TR2 is ON and discharges the C5. When TR2 is OFF, C5 is charged from +B Line through R6. This wave form is (c).

Also, at IC1-①, standard voltage appears and when the TR2's collector potential over takes this voltage, pulse signal of pulse width t_3 (as in (d)) appears in IC1-⑪. t_3 is related to speed: it widens when speed is slow and narrows when fast. During this t_3 period, TR3 is ON, CR8 charges fixed electric current and when TR3 is OFF, CR8 is discharged. This wave form is (e). (e) wave form is reversed by TR5

and added as bias voltage to the TR6 base and controls the voltages of both terminals of C11. When the voltage of both C11 terminals change, the electric current flowing in the Hall element changes. Therefore motor's torque is controlled and the speed changes. Now if the speed is slow, T increases and t_3 becomes wide. Then C8's fixed electric charging period become long and V1 decreases. When V1 decreases TR6's base voltage increases, so the voltage at both C11 terminals increases and current flowing into the Hall element increases. Thus the motor torque rises and increases speed. This is shown by the red line. Also on the other hand when speed is increased, T1 decreases, thus t_3 decreases, thus V1 increases and thus V2 decreases and thus motor torque decreases and speed decreases. Thus in this way servo circuit of sample and hold system makes for stable control.

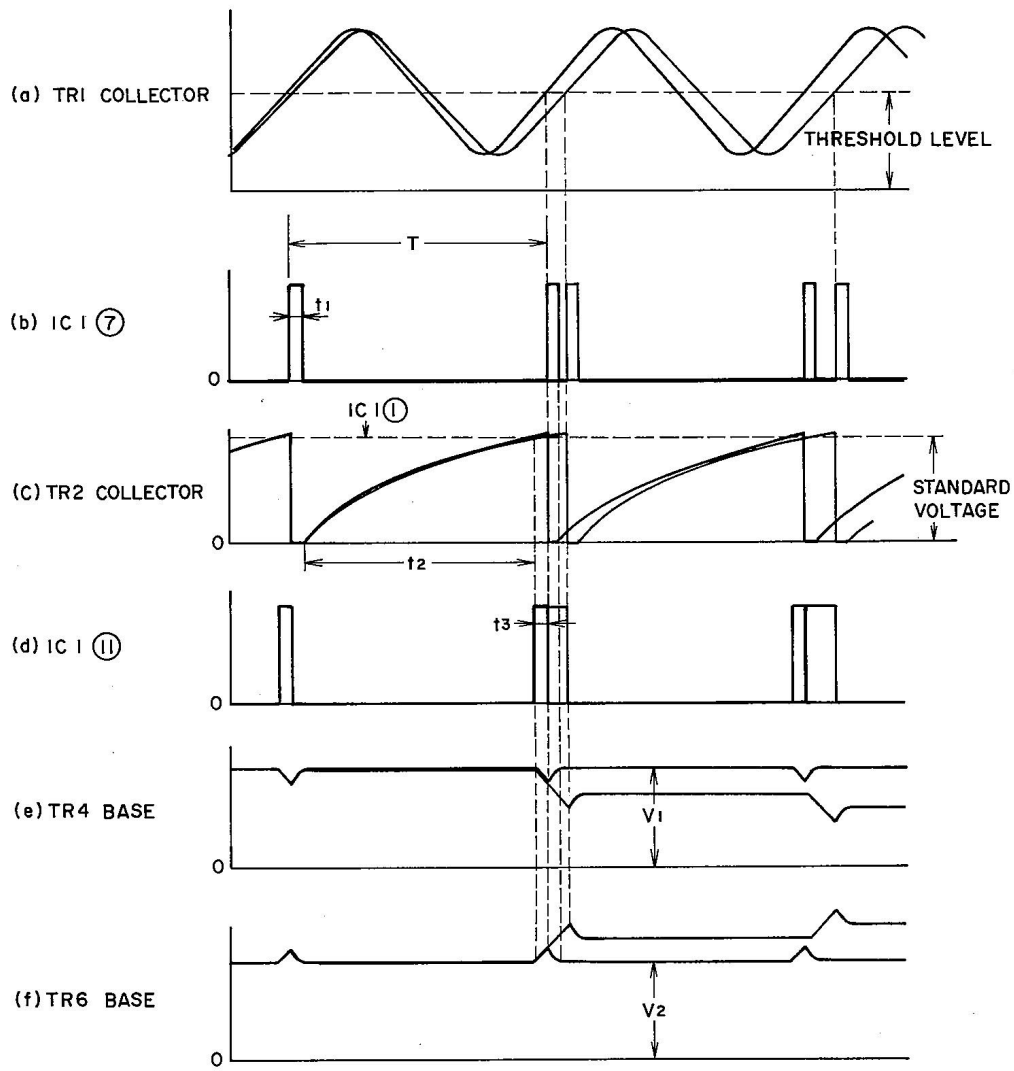

Fig. 16

VII. MECHANISM ADJUSTMENT

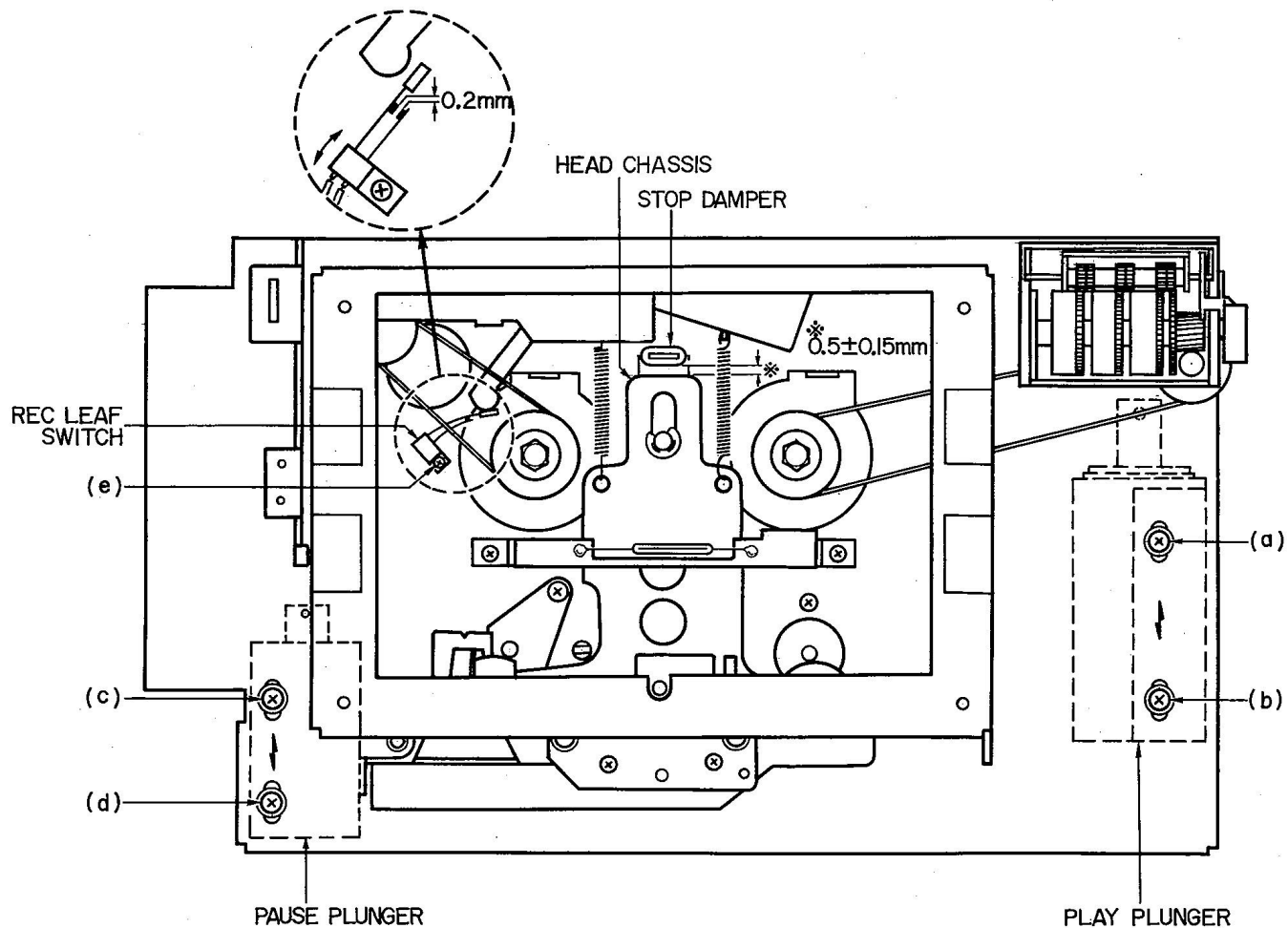

Fig. 17

1. PLAY PLUNGER INSTALLATION POSITION ADJUSTMENT (Refer to Fig. 17)

Put in PLAY mode to activate the PLAY plunger. Adjust the position of the play plunger with the installation screws (a), (b) so that the distance between the top edge of the head chassis and the stop damper is $0.5 \pm 0.15 \text{ mm}$. After adjustment coat the installation screws with screw lock.

2. PAUSE PLUNGER INSTALLATION POSITION ADJUSTMENT (Refer to Fig. 17)

Insert a head projection gauge and confirm that in the PLAY mode the head projection is $3.4 \pm 0.15 \text{ mm}$. (If it does not meet the specifications, refer to VIII. HEAD ADJUSTMENT).

Put into the PAUSE mode from the PLAY mode and adjust the PAUSE plunger's position with installation screws (c), (d) to give a head projection of

$2.4 \pm 0.1 \text{ mm}$. After adjustment, coat the installation screws with screw lock and confirm that there is a distance of about 0.5 mm between the erase head and pad, and the pinch roller and capstan.

3. REC LEAF SWITCH INSTALLATION POSITION ADJUSTMENT (Refer to Fig. 17)

Loosen the installation screw (e) and adjust the position of the REC LEAF switch until the LEAF switch contact point gap is over 0.2 mm with the EJECT button depressed, and there is sufficient LEAF switch contact point pressure with the cassette holder set.

After adjustment, insert a cassette pack with the recording defeat tabs intact to confirm there is recording and then insert a cassette pack without the recording defeat tabs and confirm that it does not record.

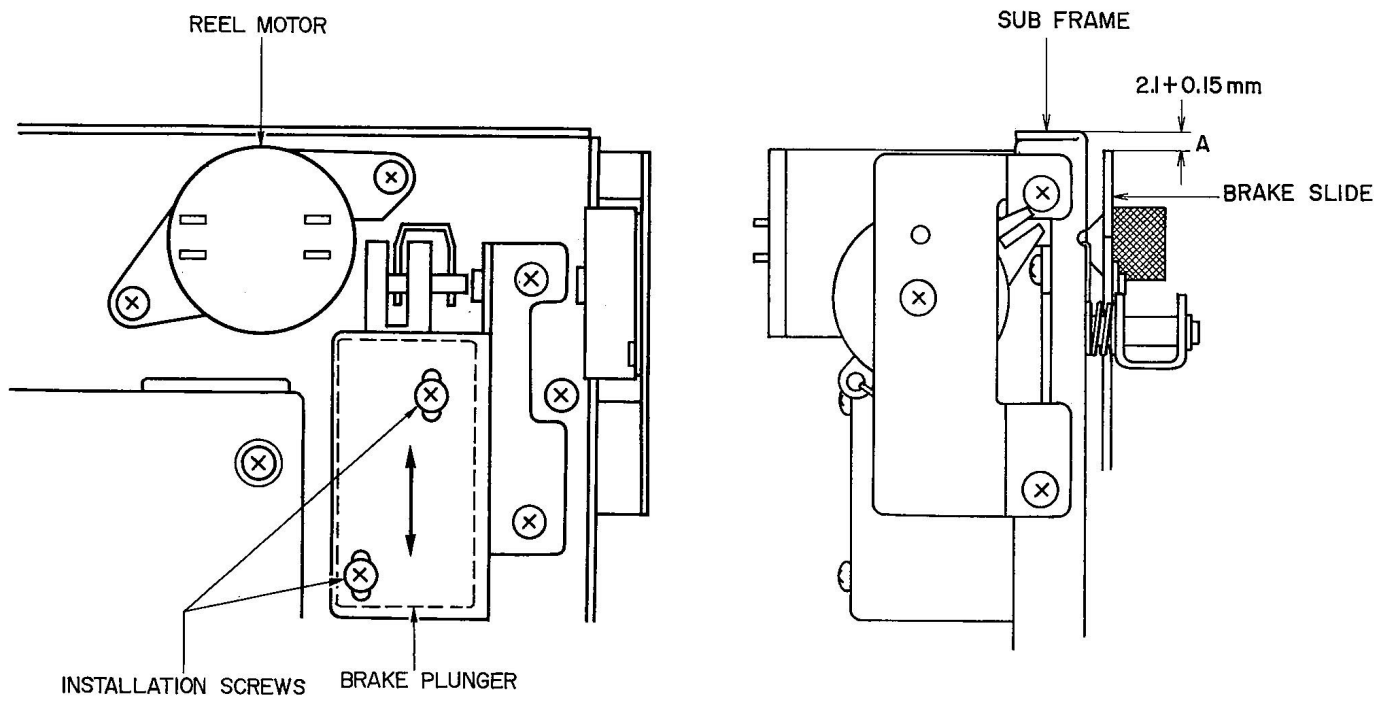

Fig. 18

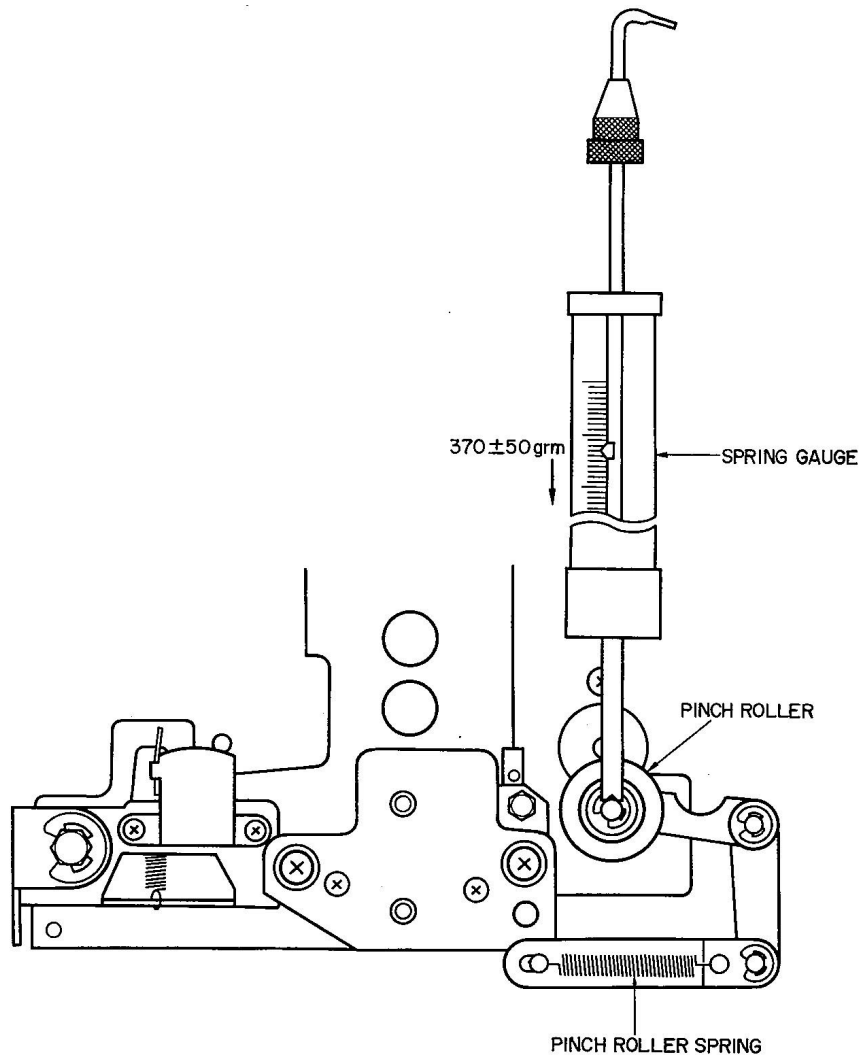

Fig. 19

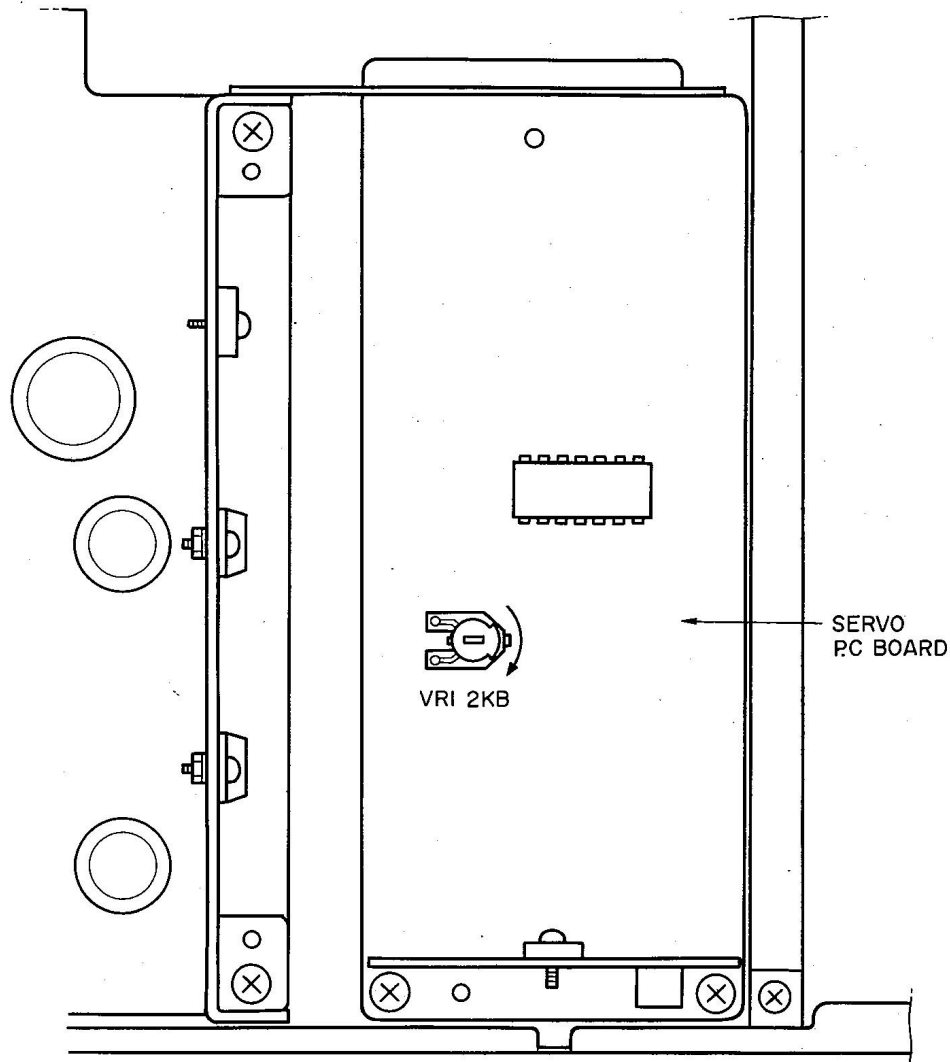

Fig. 20 Tape Speed Adjustment

4. BRAKE PLUNGER INSTALLATION POSITION ADJUSTMENT (Refer to Fig. 18)

With the brake off (for example during RWD), adjust the brake plunger's position with the installation screws (a), (b) so that the distance between the tip of the brake slide and the sub frame is 2.1 ± 0.15 mm.

5. PINCH ROLLER PRESSURE MEASUREMENT (Refer to Fig. 19)

Put in PLAY mode. Push pinch roller arm down with the spring gauge, push the pinch roller 1–2 mm from the capstan and release slowly. Read the spring gauge at the moment the pinch roller touches the capstan and begins to rotate.

Specified contact pressure measurement of 370 ± 50 gm.

If no measurement is obtained, replace the pinch roller spring. Measure while turning the Supply Reel table with one finger to activate the AUTO STOP when the supply reel table has been stopped.

6. WINDING TORQUE MEASUREMENT IN EACH MODE

Insert cassette torque meter and measure in each mode.

For fast forward and rewind measure at the end of the tape when the tape has stopped running.

The specified torque is:

Playback : 35 to 55 g-cm.

Fast Forward, Rewind : 95 to 135 g-cm.

7. TAPE SPEED ADJUSTMENT (Refer to Fig. 20)

Connect a frequency counter to LINE OUT. Playback near the middle of the 1,000 Hz test tape and adjust with the Servo P.C Board's VRI 2 kB so that the frequency counter reads $1,000 \text{ Hz} \pm 5 \text{ Hz}$.

VIII. HEAD ADJUSTMENT

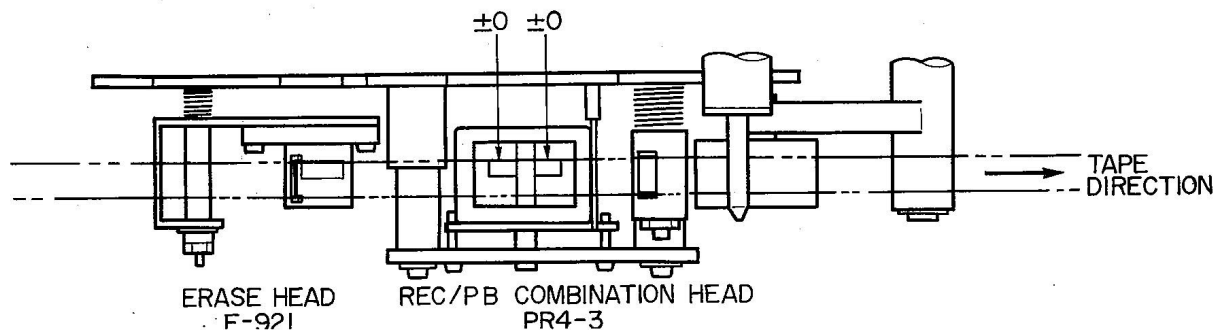
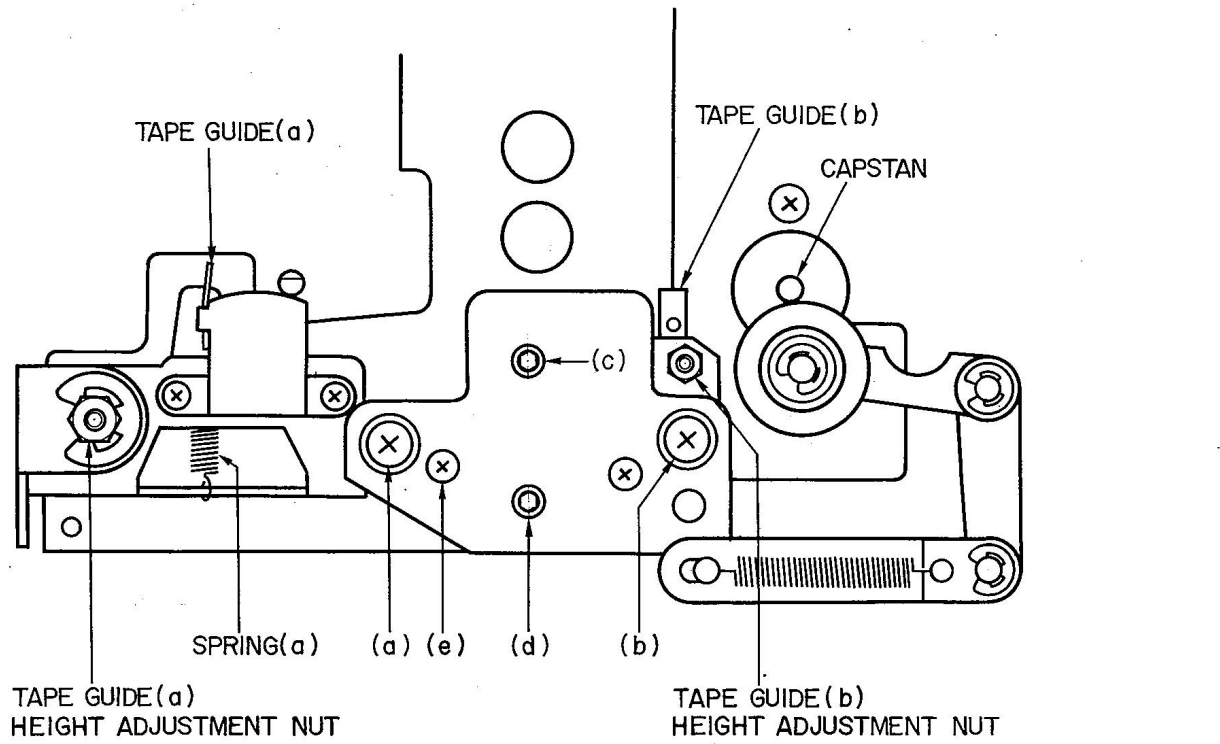

Fig. 21

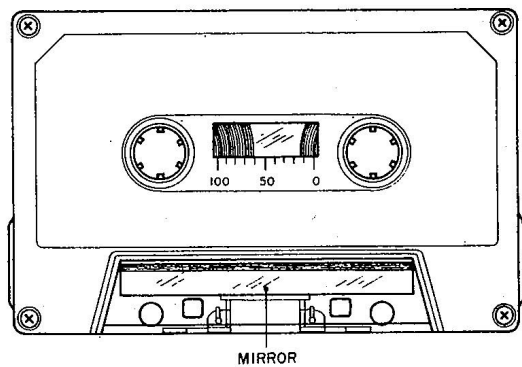

Fig. 22

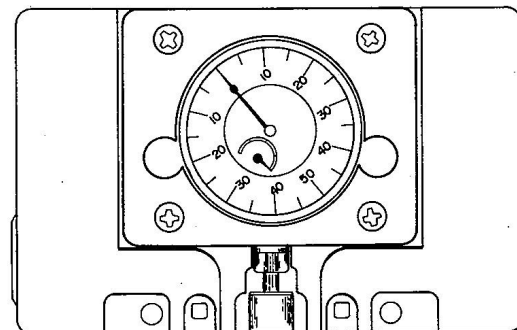

Fig. 23

1. TAPE GUIDE HEIGHT ADJUSTMENT

(Refer to Figs. 21, 22)

- 1) When using an ordinary cassette, the tape guides and heads, etc. are not visible. As shown in Fig. 22 use a cassette tape from which part of the cassette case has been cut out and a mirror installed for easy visibility of the head area when making tape guide height adjustment.
- 2) At playback mode, adjust tape guide (a) and tape guide (b) height with tape guide height adjustment nuts so that the tape runs smoothly and does not catch on the tape guides.

2. REC/PB COMBINATION HEAD PROJECTION ADJUSTMENT

(Refer to Figs. 21, 23)

Insert the AKAI Head Projection Gauge (Fig. 23) and adjust screws (a) and (b) so that it reads 3.4 ± 0.15 mm in the Playback Mode.

3. REC/PB COMBINATION HEAD HEIGHT ADJUSTMENT (Refer to Fig. 21)

- 1) Utilize the cassette tape used in Tape Guide Height Adjustment above, and playback the leader tape part of cassette tape.
- 2) As shown in Fig. 21 adjust head height with screws (c), (d) and (e) until the upper edge of the left channel REC/PB Combination head core.

4. REC/PB COMBINATION HEAD AZIMUTH ALIGNMENT ADJUSTMENT

(Refer to Fig. 21)

- 1) The cores of recording and playback heads are mounted in a single head holder to form the recording/playback combination head otherwise known as the Super GX Head. Both recording and playback head cores move when azimuth alignment is adjusted. To obtain optimum playback head core azimuth alignment, follow the instruction 2) – 5) carefully.
- 2) Playback a 10 kHz azimuth alignment adjustment test tape and adjust the adjustment screw (e) until the output levels of both channels are at maximum.
- 3) Invert cassette and see whether there is an output level difference from the above. If there is a difference, repeat 2) and readjust.
- 4) Record a 10 kHz, -20 VU signal from the audio frequency oscillator.
- 5) Rewind and check for any fluctuation in the output level at playback.

NOTES:

1. Be sure to clean the heads prior to head adjustment.
2. Be careful not to use a magnetized driver or other magnetized tools in the vicinity of the heads.
3. Be sure to demagnetize the heads with a Head Demagnetizer before and after head adjustment.
4. When a mirror installed cassette test tape as shown in Fig. 22 is required, it can be ordered from AKAI Electric Co.
5. The position where spring (a) meets the tape guide base is adjusted at the place of manufacture and readjustment is unnecessary.

IX. AMPLIFIER ADJUSTMENT

1. AMPLIFIER ADJUSTMENT (Refer to Figs. 24, 25, 26)

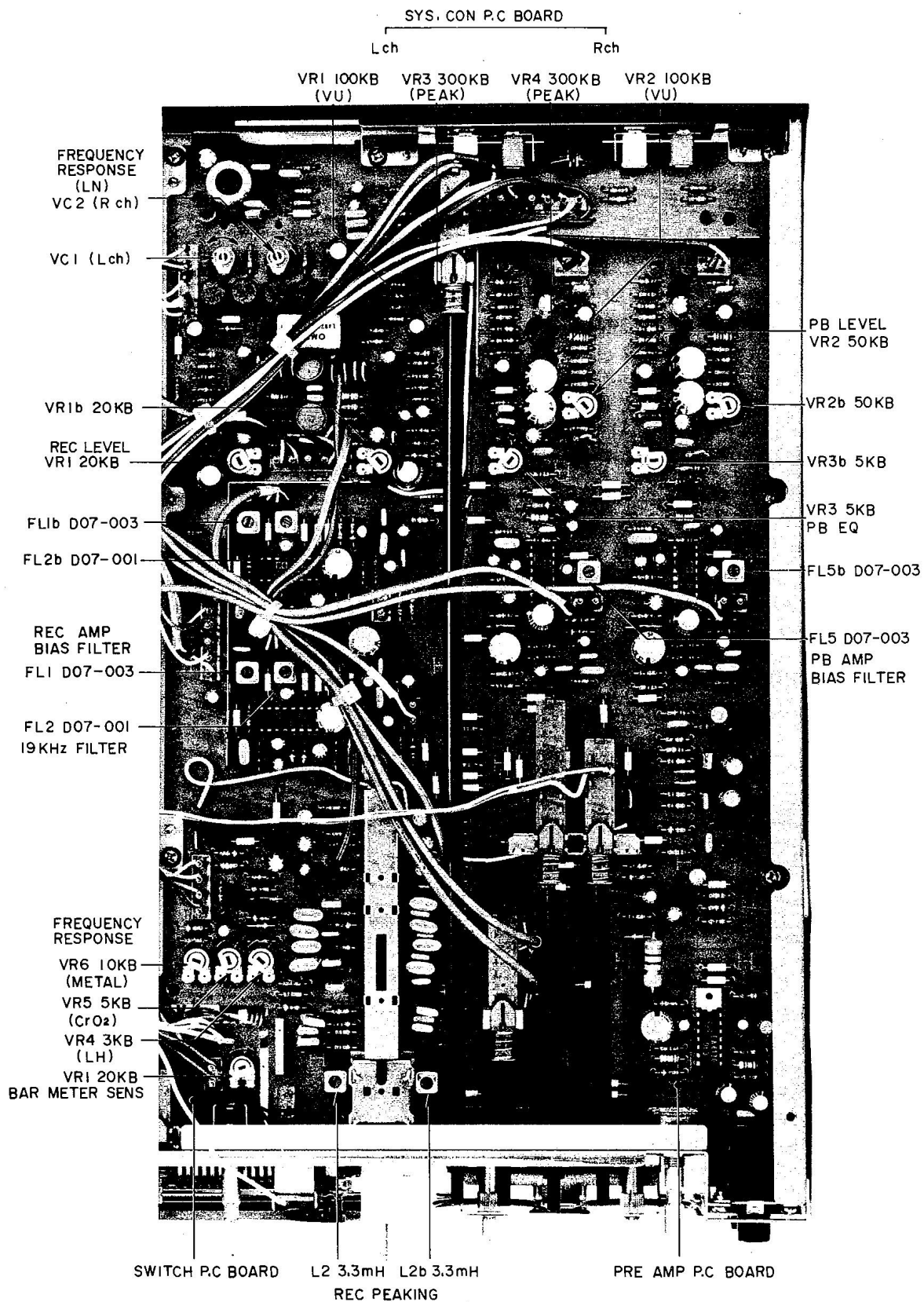

Fig. 24 Amplifier Adjustment Point

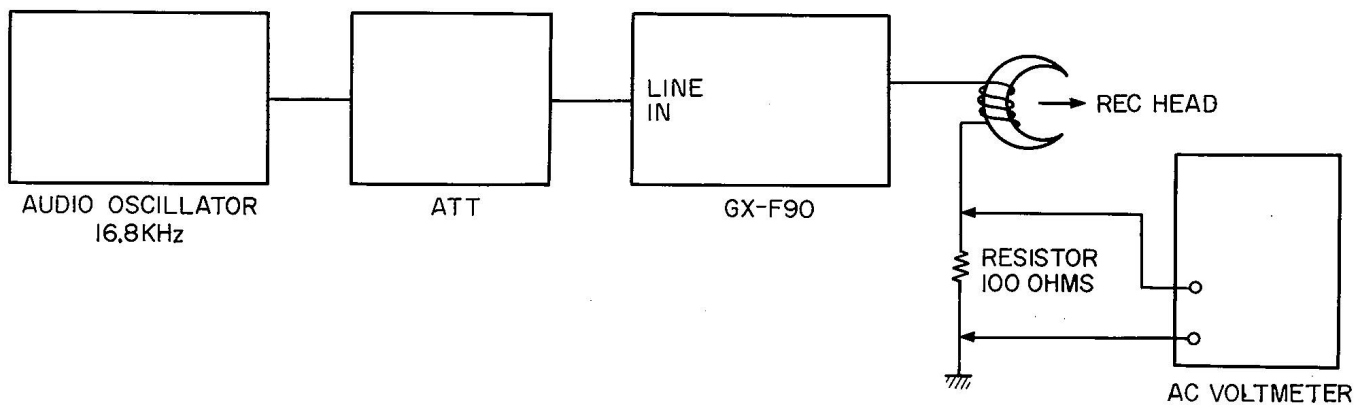

Fig. 25 Instruments Connection

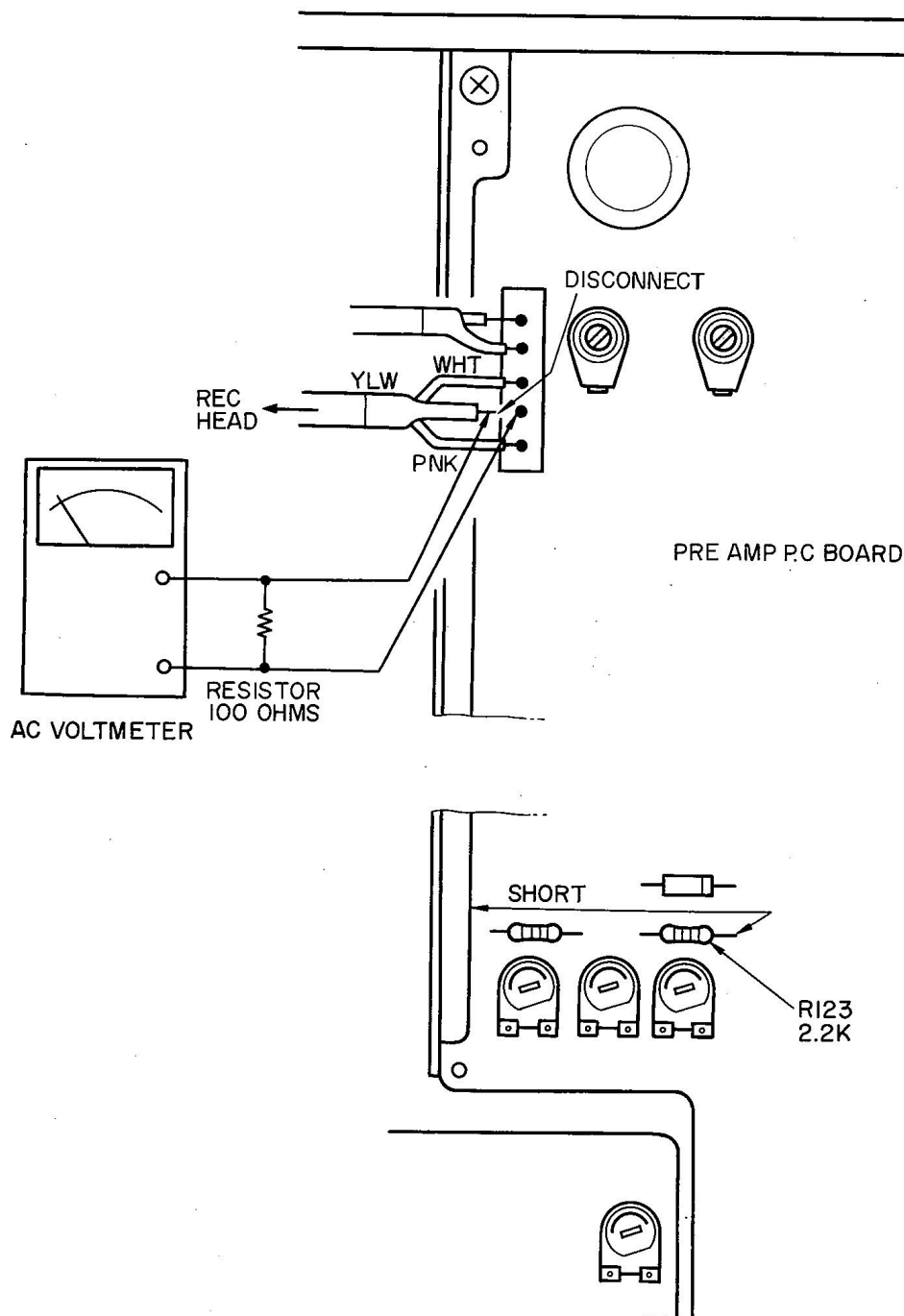

Fig. 26 Rec Peaking Adjustment

Step	Adjustment Item	Test Tape Supply Signal	Mode	Adjustment Point	Result	Remarks
1	Playback Level Adjustment	333 Hz, 0 VU Test Tape	PLAY	VR2 50 k Ω	-5.5 \pm 0.5 dBm (411 mV)	Set MONITOR SW. to SOURCE.
2	Playback Equalizer Adjustment	10 kHz Test Tape	PLAY	VR3 5 k Ω	-19.5 \pm 1 dBm	
3	Bar Meter Adjustment	Refer to Section 2 "BAR METER ADJUSTMENT".				
4	Rec Peaking Adjustment	16.8 kHz from Oscillator	REC	L2 3.3 mH	Maximum AC Voltmeter indication	Refer to NOTES 8, 9, 13 and Figs. 25, 26
5	LN Position Frequency Response Adjustment	LN Blank tape 1,000 Hz, 10,000 Hz, -25.5 dBm recording	REC/PLAY	VC1 (Lch) VC2 (Rch)	1,000 Hz to 10,000 Hz flat response	
6	LH Position Frequency Response Adjustment	LH Blank tape 1,000 Hz, 10,000 Hz, -25.5 dBm recording	REC/PLAY	VR4 3 k Ω	1,000 Hz to 10,000 Hz flat response	Set tape Selector to LH.
7	CrO ₂ Position Frequency Response Adjustment	CrO ₂ Blank tape 1,000 Hz, 10,000 Hz, -25.5 dBm recording	REC/PLAY	VR5 5 k Ω	1,000 Hz to 10,000 Hz flat response	Set tape Selector to CrO ₂ .
8	Metal Position Frequency Response Adjustment	Meter Blank tape 1,000 Hz, 10,000 Hz, -25.5 dBm recording	REC/PLAY	VR6 10 k Ω	1,000 Hz to 10,000 Hz flat response	Set tape Selector to Metal
9	Recording Level Adjustment	LN Blank tape 1,000 Hz, -5.5 dBm recording	REC/PLAY	VR1 20 k Ω	-5.5 \pm 0.5 dBm (411 mV)	
10	Distortion Factor Confirmation	1,000 Hz -5.5 dBm recording	REC/PLAY	LN : Less than 0.8% LH : Less than 0.8% CrO ₂ : Less than 0.7% Metal : Less than 0.6%		(Refer to NOTE 10)
11	REC Amp Bias Filter Adjustment	100 kHz from an oscillator	REC/PLAY	FL1 (BLU)	Minimum AC Voltmeter indicator	Set MONITOR SW. to SOURCE. Refer to NOTES 12, 13.
12	PB Amp Bias Filter Adjustment	100 kHz from an oscillator	REC/PLAY	FL5 (BLU)	Minimum AC Voltmeter indicator	Set MONITOR SW. to TAPE. Refer to NOTES 12, 13.

Step	Adjustment Item	Test Tape Supply Signal	Mode	Adjustment Point	Result	Remarks
13	MPX Filter Adjustment	19.00 kHz from an oscillator	STOP	FL2 (BLK)	Minimum AC Voltmeter indicator	Set MONITOR SW. to SOURCE. Set MPX Filter SW. to ON. Refer to NOTES 11, 13.

Chart-6

- NOTES:**
1. Output Level Control should be at maximum.
 2. Because each of these adjustments are vital to perfect Dolby NR circuit operation, be sure that they are carried out with as little error as possible.
 3. Set Rec Calibration Volume to center position.
 4. Set REPEAT, MEMORY, IPLS, CAL TONE and DOLBY NR Switch to OFF position.
 5. Except for Step 6 thru 8 and 10, set Tape Selector to LN Position.
 6. Except for Step 13, set MPX Filter switch to OFF position.
 7. Use the following cassette measuring tapes:

LN Tape	: TDK	LN2	C-60
LH Tape	: Maxell	UD	C-60
CrO ₂ Tape	: TDK	SA	C-60
Metal Tape	: TDK	MA-C	C-60
 8. Stop the recording bias oscillator while making record peaking adjustment (Refer to Figs. 25, 26).
 9. As the same earth line is used for both the Lch and Rch, adjust the Lch with the Rch lead wire (PNK) detached and the Rch with the Lch (WHT) lead wire detached.
 10. If it does not comply with the specifications, repeat Steps 5 to 9 and readjust.
 11. Adjust the oscillator's frequency to give a frequency counter reading of 19.00 kHz.
 12. Adjust the oscillator's frequency to give a frequency counter reading of 100.00 kHz.
 13. Unless the core is moved unintentionally this adjustment is not necessary.

2. BAR METER ADJUSTMENT (Refer to Figs. 24, 27, 28)

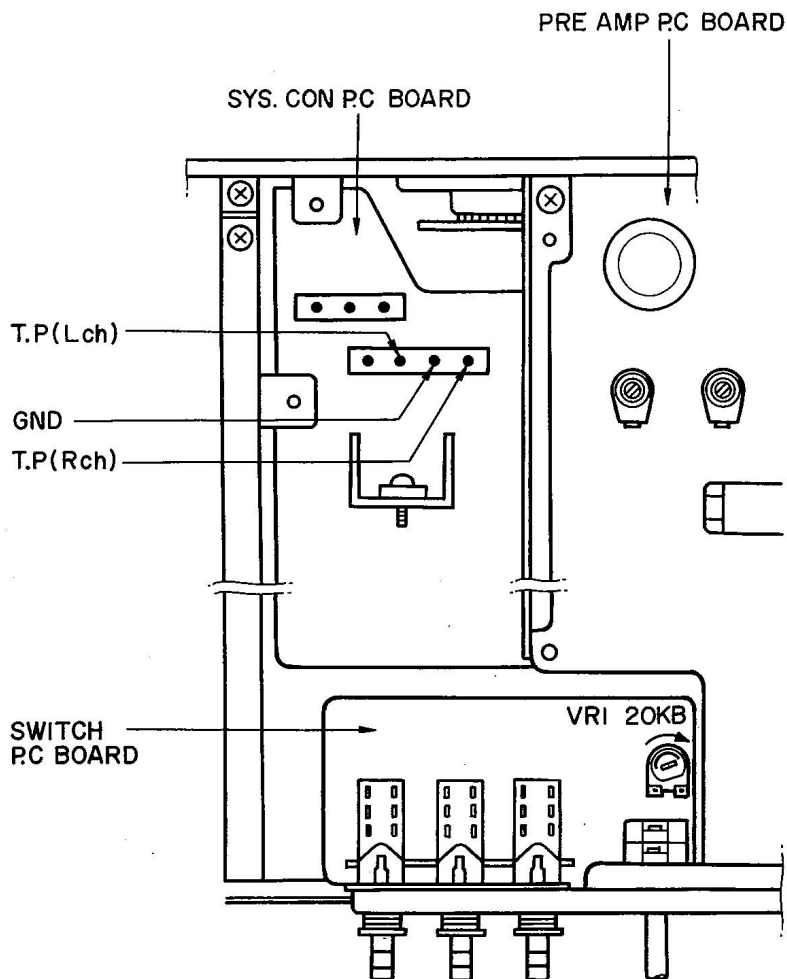

Fig. 27

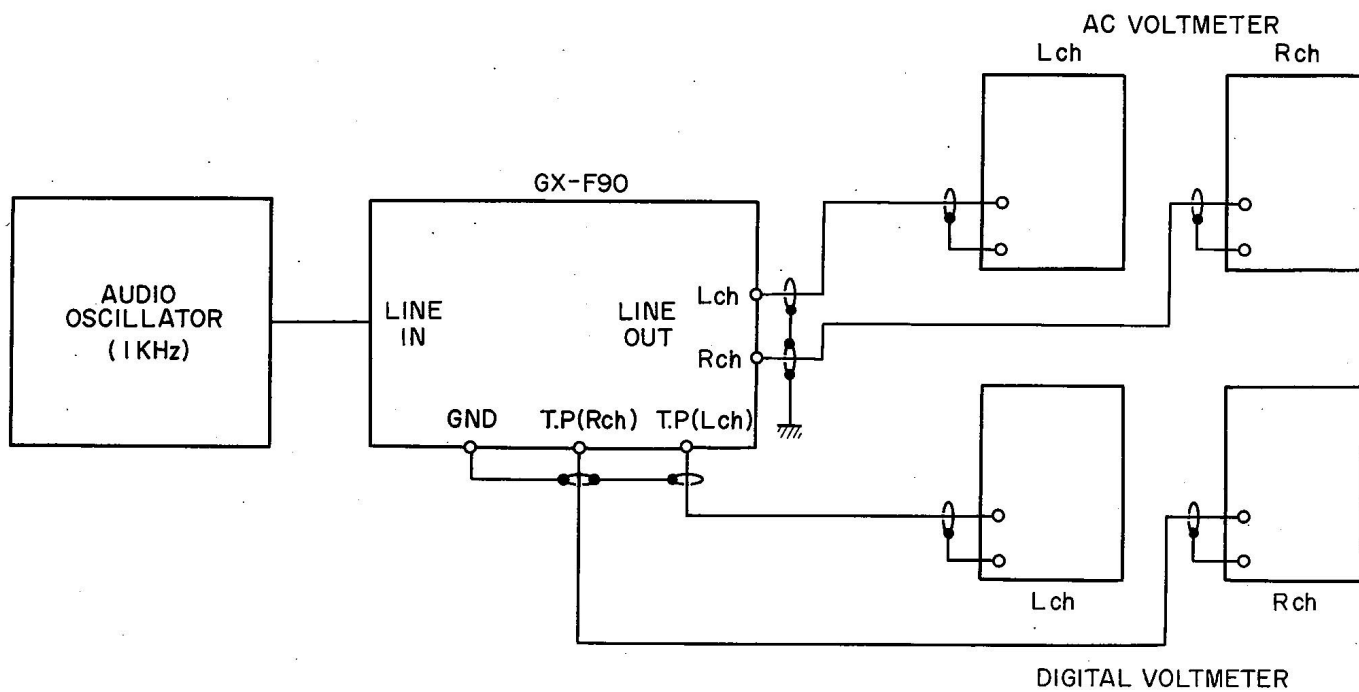

Fig. 28 Instrument Connection

Step	Adjustment Item	Supply Signal	Adjustment Point	Result	Remarks
1	Input Level Setting	1 kHz from an oscillator	LINE REC Volume	411 mV (5.5 dBm) (LINE OUT)	
2	VU Mode DC Voltage Adjustment	1 kHz from an oscillator	VR1 100 kB (Lch) VR2 100 kB (Rch) (Sys. Con P.C Board)	1.52 V \pm 0.005 V (T.P Output)	Set PEAK/VU Button to VU.
3	Bar Meter Sensitivity Adjustment	1 kHz from an oscillator	VR1 20 kB (Switch P.C Board)	0 dB indication (Bar Meter)	
4	Peak Mode DC Voltage Adjustment	1 kHz from an oscillator	VR3 300 kB (Lch) VR4 300 kB (Rch) (Sys. Con P.C Board)	0.95 V \pm 0.005 V (T.P Output)	Set PEAK/VU Button to PEAK.
5	Peak Meter Indication Confirmation	1 kHz from an oscillator		-7 dB indication (Bar Meter)	

Chart-7

- NOTES:**
1. Adjust when 3 secs have elapsed after the power is switched on.
 2. Put the monitor switch to SOURCE and the output volume to MAX.

X. DC RESISTANCE OF VARIOUS COILS

Parts	Designation	DC Resistance
Recording/Playback Head	PR4-3	Playback: 250 ohms \pm 10% Recording: 22.5 ohms
Erase Head	E-921	1.6 ohms \pm 20%
Play Plunger Solenoid	1240THTI	100 ohms \pm 10%
Pause Plunger Solenoid	1037THTI	120 ohms \pm 10%
Brake Plunger Solenoid	0730THT7	110 ohms \pm 10%

Chart-8

XI. CLASSIFICATION OF VARIOUS P.C BOARDS

1. P.C BOARD TITLES AND IDENTIFICATION NUMBERS

P.C Board Title	P.C Board Number
Power Supply P.C Board	CU-5030
Servo P.C Board	CU-5031
Sys. Con P.C Board	CU-5032A
Switch P.C Board	CU-5032B
Socket P.C Board	CU-5032C
Pre Amp P.C Board	CU-5033
LED P.C Board (A)	CU-5034
LED P.C Board (B)	CU-5035
Mixing Amp P.C Board	CU-5036
Bar Meter P.C Board	CU-5037
Selector Lamp P.C Board	CU-5038
Housing Lamp P.C Board	CU-1026
Motor P.C Board	CU-7007

Chart-9

2) SYS. CON P.C BOARD CU-5032A and SOCKET P.C BOARD CU-5032C

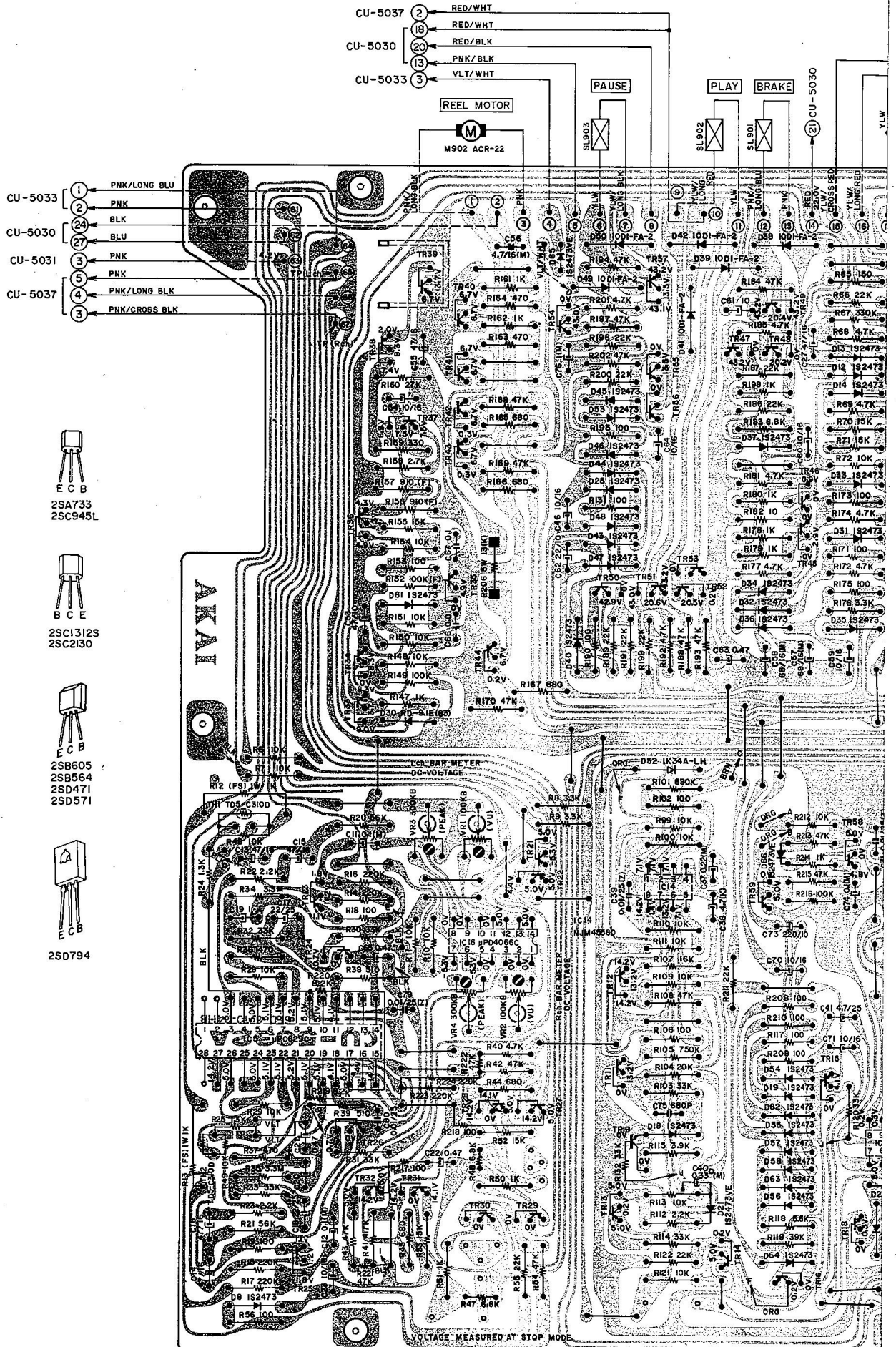

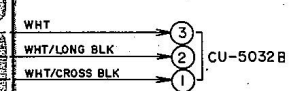
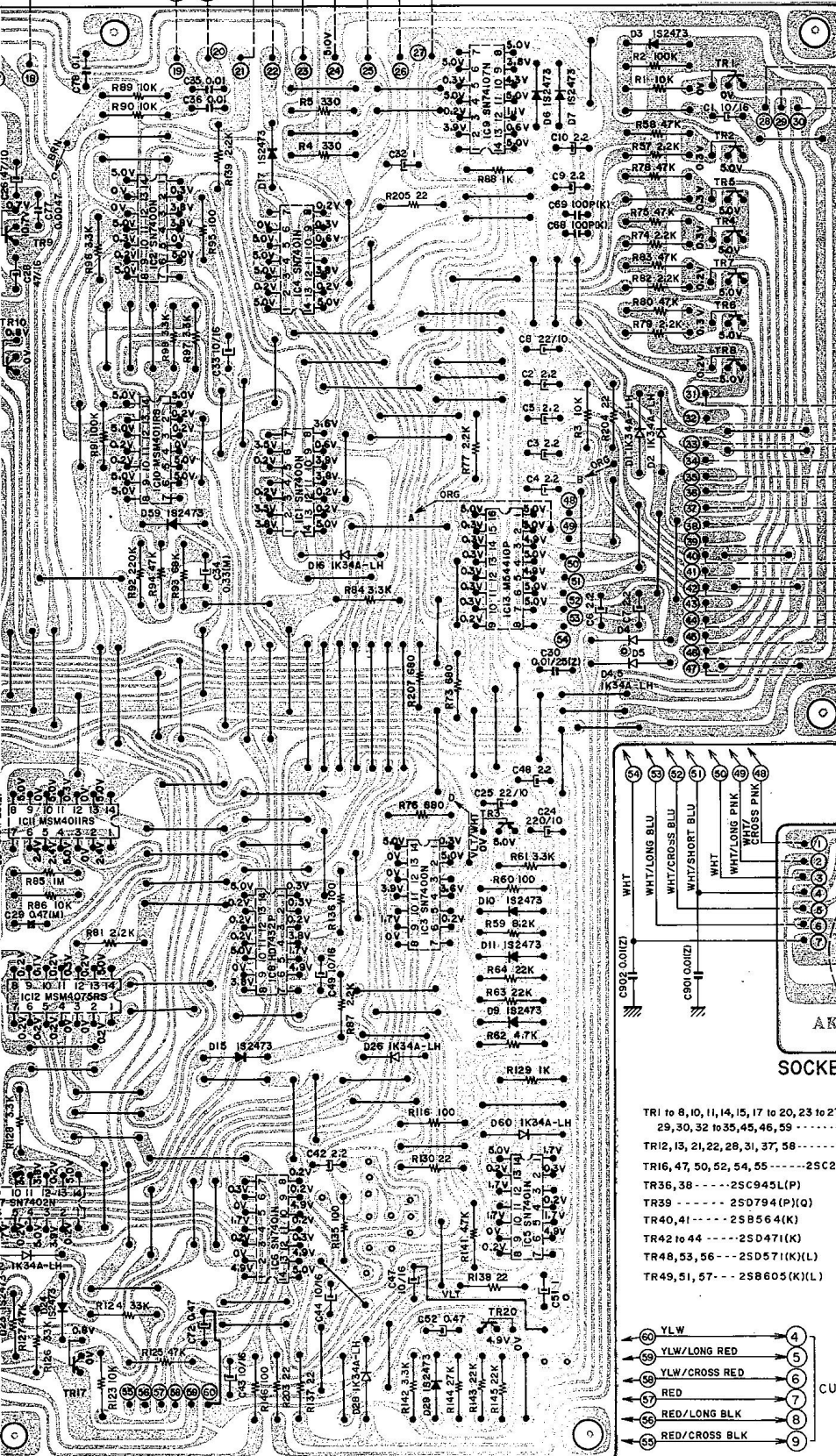
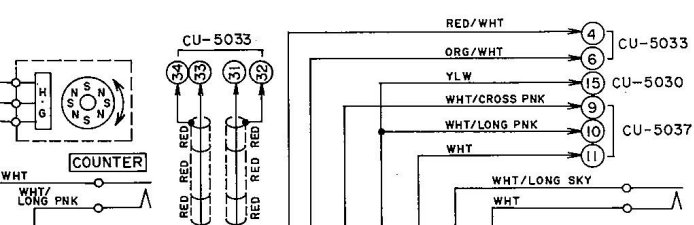

WHT	1
WHT/LONG SKY	2
WHT/CROSS SKY	3
WHT/SHORT SKY	4
YLW	5
YLW/LONG RED	6
YLW/CROSS RED	7
YLW/SHORT RED	8
WHT	9
WHT/LONG BLK	10
WHT/CROSS BLK	11
WHT/SHORT BLK	12
WHT	13
WHT/LONG BLK	14
WHT/CROSS BLK	15
WHT/SHORT BLK	16

OPERATION BUTTON BLOCK

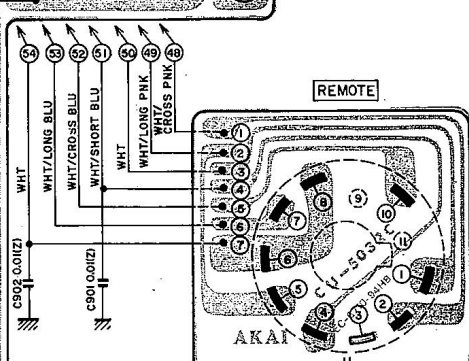

SOCKET P.C BOARD CU-5032C

- TR1 to 8, 10, 11, 14, 15, 17 to 20, 23 to 27
29, 30, 32 to 35, 45, 46, 59 2SC945L(P)(O)
- TR12, 13, 21, 22, 28, 31, 37, 58 2SA733(P)(Q)
- TR16, 47, 50, 52, 54, 55 2SC2130(G)(H)
- TR36, 38 2SC945L(P)
- TR39 2SD794(P)(Q)
- TR40, 41 2SB564(K)
- TR42 to 44 2SD471(K)
- TR48, 53, 56 2SD571(K)(L)
- TR49, 51, 57 2SB605(K)(L)

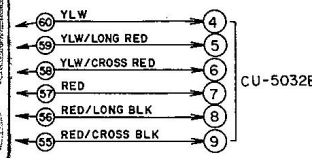

SYS.CON P.C BOARD CU-5032A

5) SWITCH P.C BOARD CU-5032B and LED P.C BOARD (B) CU-5035

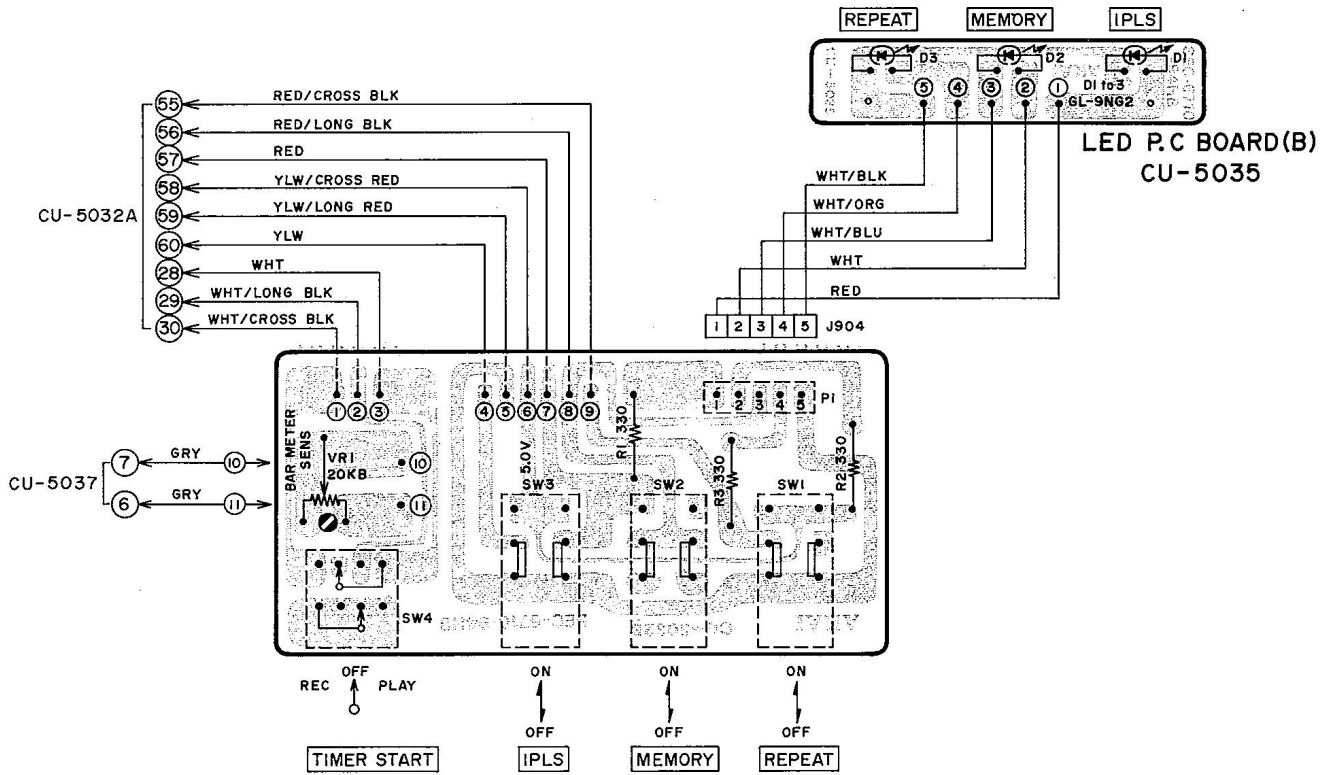

6) SERVO P.C BOARD CU-5031

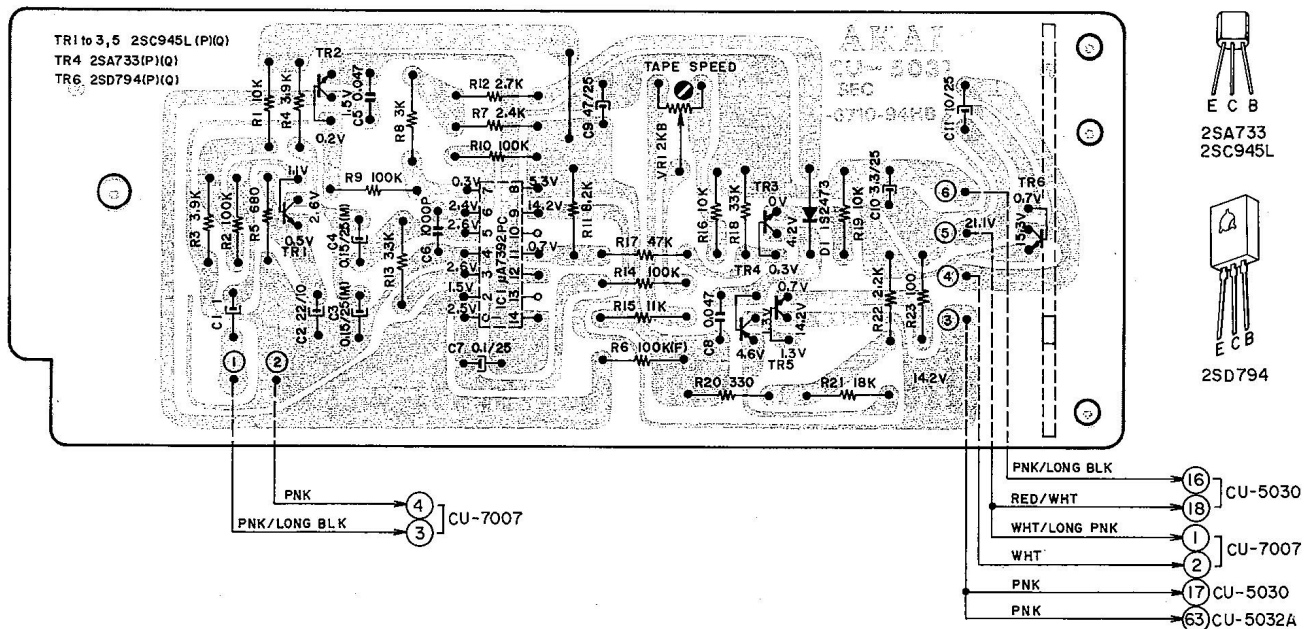

7) MOTOR P.C BOARD CU-7007

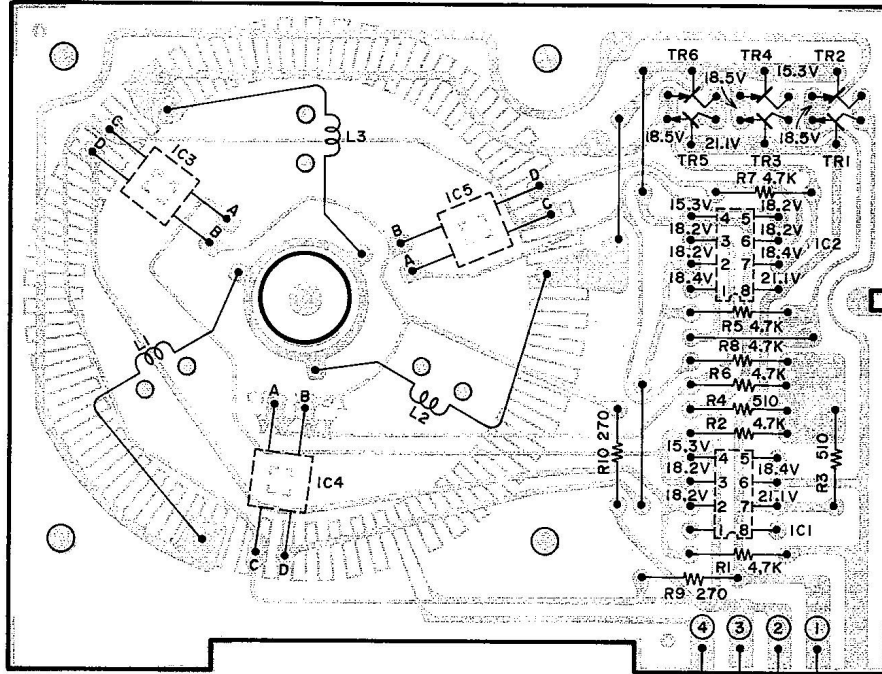
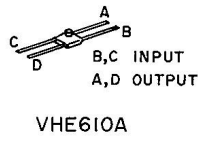
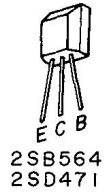

- TR1,3,5 2SD471 (M)(L)
- TR2,4,6 2SB564(M)(L)
- IC1 μ PC74IC
- IC2 NJM4558D
- IC3 to 5 VHE610A

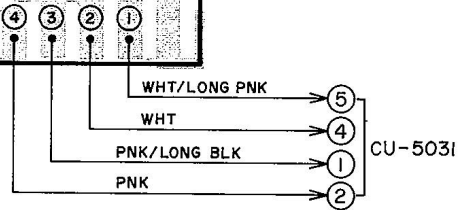

CSA, AAL, JPN

CSA: AC120V 60Hz
 AAL: AC120V 60Hz
 JPN: AC100V 50/60Hz

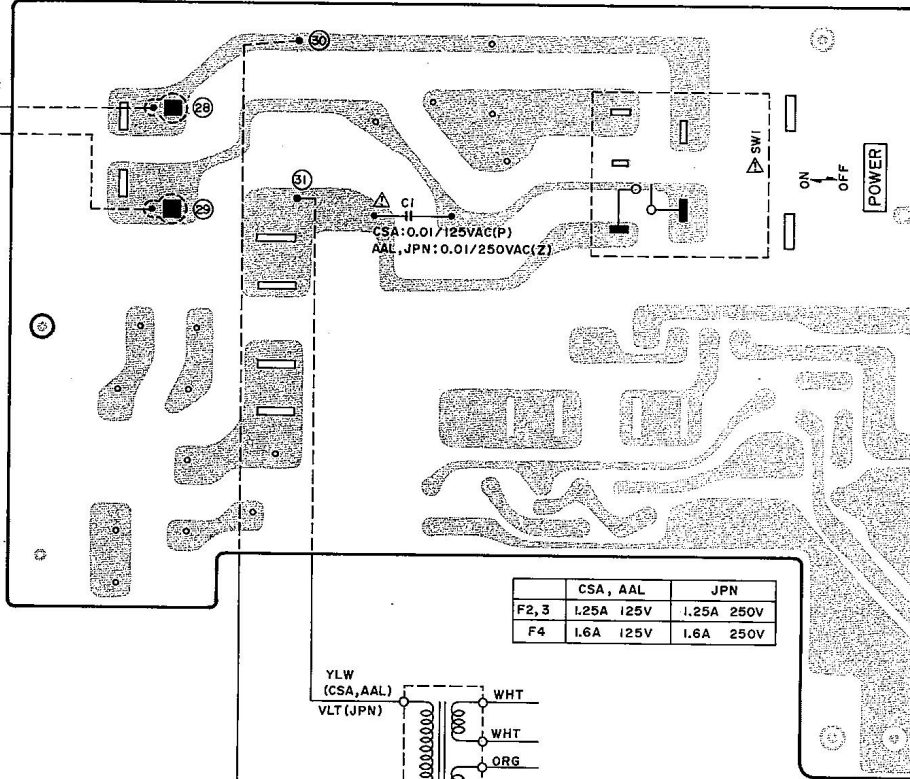

	CSA, AAL	JPN
F2, 3	1.25A 125V	1.25A 250V
F4	1.6A 125V	1.6A 250V

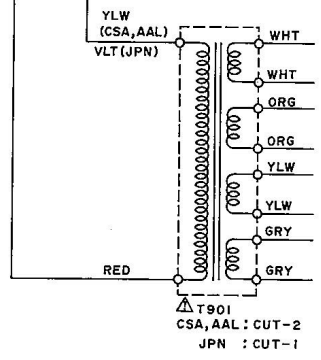

T901
 CSA, AAL : CUT-2
 JPN : CUT-1

WARNING: Δ INDICATES SAFETY CRITICAL COMPONENTS. FOR CONTINUED SAFETY, REPLACE SAFETY CRITICAL COMPONENTS ONLY WITH MANUFACTURER'S RECOMMENDED PARTS

AVERTISSEMENT: Δ IL INDIQUE LES COMPOSANTS CRITIQUES DE SÛRETÉ. POUR MAINTENIR LE DEGRÉ DE SÛRETÉ DE L'APPAREIL NE REMPLACER LES COMPOSANTS DONT LE FONCTIONNEMENT EST CRITIQUE POUR LA SÛRETÉ QUE PAR DES PIÈCES RECOMMANDÉES PAR LE FABRICANT

SECTION 2

PARTS LIST

TABLE OF CONTENTS

1. RECOMMENDED SPARE PARTS LIST	54
2. HEAD BASE BLOCK	58
3. SUB FRAME BLOCK	59
4. MECHA ASSEMBLY BLOCK	60
5. EJECTOR BLOCK	62
6. SYS. CON P.C BOARD (CU-5032A) BLOCK	63
7. PRE AMP P.C BOARD (CU-5033) BLOCK	64
8. POWER SUPPLY P.C BOARD (CU-5030) BLOCK	64
9. SERVO P.C BOARD (CU-5031) BLOCK	65
10. MIXING AMP P.C BOARD (CU-5036) BLOCK	65
11. MOTOR P.C BOARD (CU-7007) BLOCK	65
12. SWITCH P.C BOARD (CU-5032B) BLOCK	65
13. FINAL ASSEMBLY BLOCK (1)	66
14. FINAL ASSEMBLY BLOCK (2)	68
INDEX	69

Resistor and Capacitor which is not listed in this parts list, please refer to COMMON LIST FOR SERVICE PARTS.

HOW TO USE THIS PARTS LIST

1. This parts list is compiled by various individual blocks based on assembly process.
2. When ordering parts, please describe parts number, serial number, and model number in detail.
3. How to read List

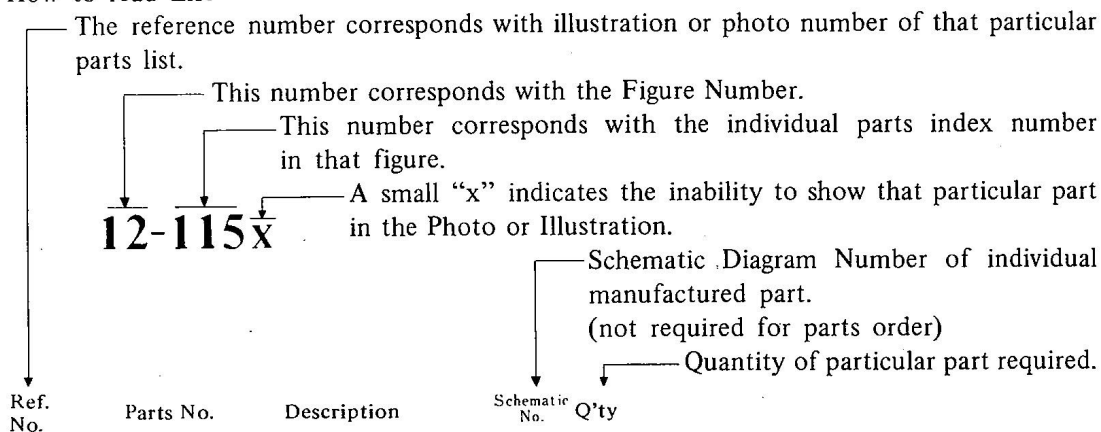

FLYWHEEL BLOCK #13

12-115x	800425	Flywheel Block Assy. Comp.	RDG #13	1
12-116	244506	Flywheel Only	RD-233	1
12-117x	244754	Felt, Flywheel	RD-275	1
12-118	251324	Main Metal Case	RD-236	1
12-119	253080	Main Metal	RD-237	1

4. The symbol numbers shown on the P.C. Board list can be matched with the Composite Views of Components of the Schematic Diagram or Service Manual.
5. Please utilize separate "Common List for Service Parts" for Resistor Parts orders.
6. The shape of the parts and parts name, etc. can be confirmed by comparing them with the parts shown on the Electrical Parts Table of P.C. Board.
7. Both the kind of part and installation position can be determined by the Parts Number. To determine where a parts number is listed, utilize Parts Index at end of Parts List.
It is necessary first of all to find the Parts Number. This can be accomplished by using the Reference Number listed at right of parts number in the Parts Index. (meaning of ref. no. outlined in Item 3 above).
8. Utilize separate "Price List for Parts" to determine unit price. The most simple method of finding parts Price is to utilize the reference number.

- CAUTION:**
1. When placing an order for parts, be sure to list the parts no. model no., and description. There are instances in which if any of this information is omitted, parts cannot be shipped or the wrong parts will be delivered.
 2. Please be careful not to make a mistake in the parts no. If the parts no. is in error, a part different from the one ordered may be delivered.
 3. Because parts number and parts unit supply in the Preliminary Service Manual (Basic Parts List) may be partially changed, please use this parts list for all future reference.

WARNING: **▲** INDICATES SAFETY CRITICAL COMPONENTS. FOR CONTINUED SAFETY, REPLACE SAFETY CRITICAL COMPONENTS ONLY WITH MANUFACTURER'S RECOMMENDED PARTS.

AVERTISSEMENT: **▲** IL INDIQU LES COMPOSANTS CRITIQUES DE SURETE. POUR MAINTENIR LE DEGRE DE SECURITE DE L'APPAREIL NE REMPLACER LES COMPOSANTS DONT LE FONCTIONNEMENT EST CRITIQUE POUR LA SECURITE QUE PAR DES PIECES RECOMMANDEES PAR LE FABRICANT.

AC INLET SYSTEM

This model is equipped with an AC INLET SYSTEM. Please refer to the AC INLET SYSTEM CHART below for the specific type. By the AC INLET SYSTEM, AC (mains) cord can be connected to and disconnected from the model because the model is provided with socket exclusively for AC (mains) cord on its main body.

Please note, however, that certain models are not equipped with this system and has a built-in AC (mains) cord as before.

AC INLET SYSTEM CHART

CLASS I

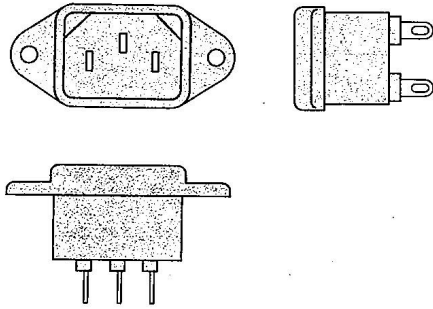

Picture 1
AC INLET
to be
installed
on machines

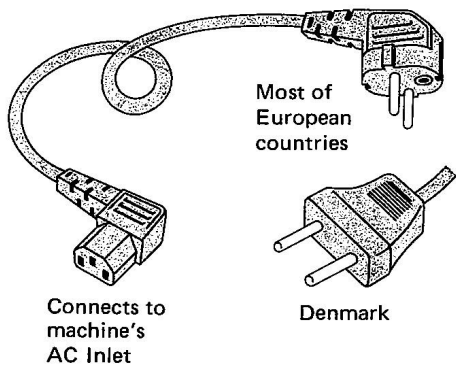

Picture 2
AC (mains)
cord

CLASS II

☐ This mark indicating double insulation will be attached to machine's rear panel

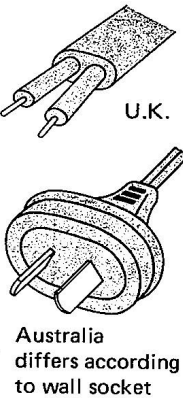
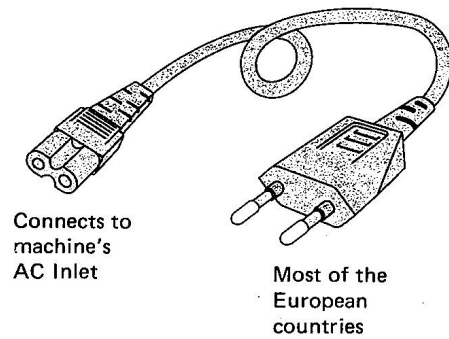
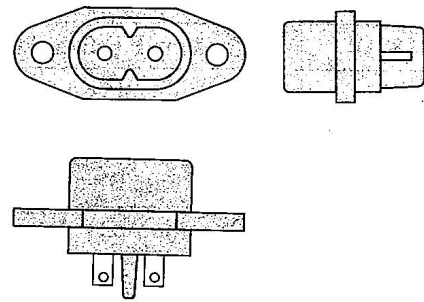

Parts List for AC (mains) Cord Set

Standard		Description	Type of AC Inlet	Parts No.
Class I	CEE	Cord Set CEE (3 cores)	3P	EW302993
	BEAB	Cord Set BEAB (3 cores)	3P	EW302994
	SAA	Cord Set SAA (3 cores)	3P	EW302996
	U/T	Cord Set U/T (3 cores)	3P	EW302646
Class II	CEE	Cord Set CEE (2 cores)	2P	EW638144
	BEAB	Cord Set BEAB (2 cores)	2P	EW302995
	SAA	Cord Set SAA (2 cores)	2P	EW302991
	U/T	Cord Set U/T (2 cores)	2P	EW302899

1. RECOMMENDED SPARE PARTS LIST

Because, if the parts listed below are on hand, almost any repair can be accomplished, we suggest that you stock these Recommended Spare Parts Items.

Parts No.	Description	Notes
BA318736	Mixing Amp P.C Board Comp. GX-F90	
BA314206	Power Supply P.C Board Comp. GX-F90 (AAL)	
BA318733	Power Supply P.C Board Comp. GX-F90 (CSA)	
BA318732	Power Supply P.C Board Comp. GX-F90 (JPN)	
BA318731	Power Supply P.C Board Comp. GX-F90 (U/T)	U/T, CEE, UK
BA318713	Pre Amp P.C Board Comp. GX-F90 (U/T)	U/T, CSA, CEE, UK
BA318714	Pre Amp P.C Board Comp. GX-F90 (JPN)	AAL, JPN
BA318717	Servo P.C Board Comp. GX-F90	
BA318724	Sys. Con P.C Board Comp. GX-F90	
BH318691	Head Base Block Comp. GX-F90	
BK318678	Operation Key Assy GX-F90	
BK318791	Operation Key Assy GX-F90-BL	
BM318690	Motor Block Comp.	
BM318696	Reel Motor Block Comp. w/Pully GX-F90	
BT317585	⚠ Power Trans. CUT-1	JPN
BT317587	⚠ Power Trans. CUT-2	CSA, AAL
BT317588	⚠ Power Trans. CUT-3	U/T, CEE, UK
EC322419	Elect./C. (Vert.) 3300 μ F 25WV	
EC322803	Elect./C. (Vert.) 4700 μ F 16WV	
EC315346	Trimmer/C. ECV-1ZW 50x32E	
ED308953	Germanium Diode 1K34A-LH	
ED219464	Germanium Diode 1N34A	
ED326142	LED GL-9NG51	
ED313566	Silicon Diode GP-25G	
ED308945	Silicon Diode SVB10-100	
ED309357	Silicon Diode SVB15-100	
ED624903	Silicon Diode 1S2473	
ED560913	Silicon Diode 1S2473-VE	
ED316143	Silicon Diode 1S2473-HS	
ED317594	Silicon Diode 1S2473-HL	
ED318292	Silicon Diode 1S2473T-77	
ED322299	Silicon Diode 10D1-FA-2	
ED319463	Silicon Stack 4B4B41-100	
ED317669	Thermister TD5-C310D	
ED321180	Zener Diode HZ-9B-2	
ED306983	Zener Diode HZ12C-3	
ED313623	Zener Diode HZ22-3	
ED319167	Zener Diode HZ6C-3	
ED322410	Zener Diode RD-9.1E (B3)	
EF309392	⚠ Fuse 1.25A 125V	CSA, AAL

Parts No.	Description	Notes
EF306949	△ Fuse 1.25A 250V	JPN
EF308847	△ Fuse 1.6A 125V	CSA, AAL
EF311839	△ Fuse 1.6A 250V	JPN
EF602550	△ Fuse (Semko T Type) 1.25AT 250V	U/T, CEE, UK
EF601964	△ Fuse (Semko T Type) 1.6AT	U/T, CEE, UK
EF623103	△ Fuse (Semko T Type) 1AT	U/T, CEE, UK
EI317567	Hole Element VHE610A	
EI250740	IC MSM4001	
EI250738	IC MSM4011	
EI634083	IC SN7402N	
EI634140	IC SN74107N	
EI301749	IC μ PC741C	
EI301463	IC CR-713B	
EI317654	IC HD7432P	
EI306141	IC LA4170	
EI317557	IC MSA-803	
EI317659	IC MSM4075	
EI430661	IC M53200P	
EI308936	IC M54410P	
EI213390	IC NJM4558D	
EI317660	IC SN7401N	
EI317581	IC μ A7392	
EI317652	IC μ PC629C	
EI317653	IC μ PD4066	
EJ310567	△ Inlet, Board Type	U/T, CEE, UK
EJ305629	Headphone Jack JL3A	
EJ315746	Mic Jack HLJ0278-01-030	
EJ318709	Pin Jack Assy	U/T, CSA, CEE, UK
EJ318710	Pin Jack Assy	AAL, JPN
EL317634	Lamp	
EL317599	Lamp (Lead Type) 6.3V 100MA	
EM317556	FL Display BG-49	
EO310608	Ferri Inductor FE-001 3.3MH	
EO302464	Inductor RX-9P 33MH (J)	
EO301466	OSC. Coil 28N-503	
EO315758	Trap Coil 100S-431	
EP317583	Plunger 0730THTI	
EP313498	Plunger 1037THTI	
EP317571	Plunger 1240THTI	
EP308973	Relay LAB2NS DC24V	

Parts No.	Description	Notes
ER309119	Dolby Filter D07-001	
ER309120	Dolby Filter D07-003	
ES315159	△ Push SW. SDG1P (JPN)	
ES665875	△ Push SW. SDG1P-J TV-3 UL/CSA	AAL
ES655806	△ Push SW. SDG1P-J TV-3	CSA
ES665807	△ Push SW. SDG5P-E 5A/80A 250V	U/T, CEE, UK
ES315879	△ Volt Change SW. HXW0144	U/T, CEE, UK
ES317622	Leaf SW. BSW-47PB	
ES317605	Push SW. SUF	
ES317606	Push SW. SUF	
ES317550	Push SW. SUF32	
ES302508	Revolution SW. HZR1006	
ES317551	Rotary SW. SRU1023N	
ES317563	Rotary SW. SRZW	
ET317603	FET 2SK68 (N)	
ET302466	FET 2SK68A (Special)	
ET317418	Transistor 2SA628 (G) (H)	
ET539133	Transistor 2SA733 (P)	
ET554657	Transistor 2SA733 (P) (Q)	
ET302456	Transistor 2SA906 (G) (H)	
ET317688	Transistor 2SB564 (K)	
ET317566	Transistor 2SB564 (L) (M)	
ET666415	Transistor 2SB605 (K) (L)	
ET603257	Transistor 2SC1312S (G) (H)	
ET242684	Transistor 2SC1312S (H)	
ET301249	Transistor 2SC1846 (Q) (R)	
ET308937	Transistor 2SC2130 (G) (H)	
ET309334	Transistor 2SC458 (C) (D)	
ET391768	Transistor 2SC458LG (C) (D)	
ET563905	Transistor 2SC711 (G) (H)	
ET429748	Transistor 2SC711 (H)	
ET638504	Transistor 2SC945L (P)	
ET639437	Transistor 2SC945L (Q) (P)	
ET317331	Transistor 2SD234 (R) (O) 2-10-B	
ET317689	Transistor 2SD471 (K)	
ET317565	Transistor 2SD471 (L) (M)	
ET666404	Transistor 2SD571 (K) (L)	
ET307349	Transistor 2SD794 (P) (Q)	
ET320296	Transistor 2SD837 (P) (Q)	
EV317559	Double Axial 2-Throw/Vol. DM20R 100kAx2	

Parts No.	Description	Notes
EV305637	Semi-Fixed/Vol. D8 Axial Type 10kB	
EV305639	Semi-Fixed/Vol. D8 Axial Type 20kB	
EV305635	Semi-Fixed/Vol. D8 Axial Type 5kB	
EV305636	Semi-Fixed/Vol. D8 Axial Type 50kB	
EV300270	Semi-Fixed/Vol. V8K4-1 B300K	
EV464231	Semi-Fixed/Vol. V8K4-1 100kB	
EV522797	Semi-Fixed/Vol. V8K4-1 20K(B)	
EV317580	Semi-Fixed/Vol. (Metallized Film) TM8K (PV) 2kB	
EV317607	Single-Axial 2-Throw/Vol. GM80R 10kBx2	
EV317558	Vol. (Center Click) 10kB	
EW306427	△ AC Cord	JPN
EW305691	△ AC Cord CUL	CSA, AAL
EW322400	△ AC Cord Set BASEC 2 Cores	UK
EW315767	△ AC Cord Set CEE 2 Cores	CEE
EW322401	△ AC Cord Set SAA 2 Cores	SAA
EW306152	△ AC Cord Set U/T Type 2	U/T
HE315742	Erase Head E-921	
MB317387	Counter Belt	
MB317388	Revolution SW. Belt	
MC318793	Counter (BL) GX-F90-BL	
MC318792	Counter Part GX-F90	
MI321191	Idler Assy	
MP319580	Pinch Roller Part GX-F90	
MT312122	Reel Table Part GXC-715D	

2. HEAD BASE BLOCK

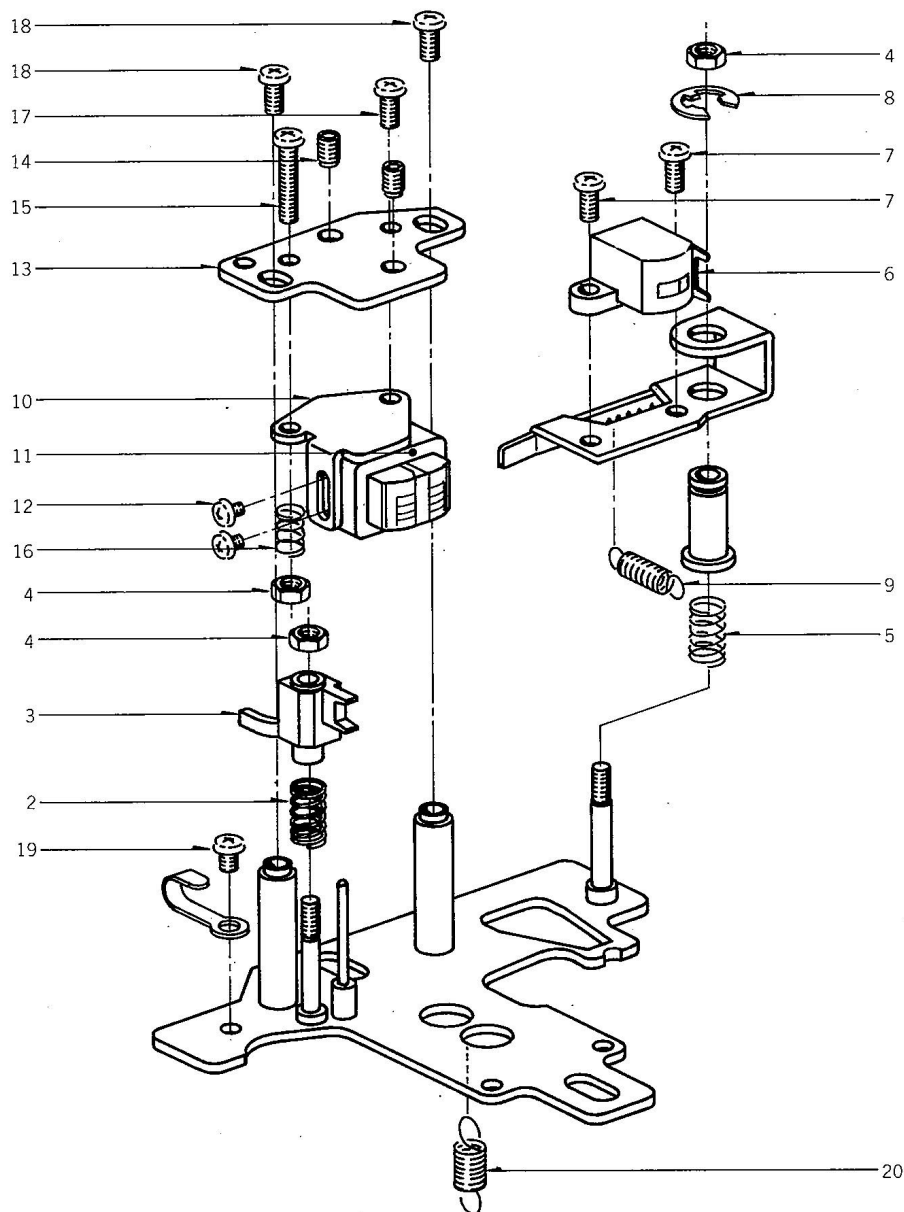

HEAD BASE BLOCK

Ref. No.	Parts No.	Description	Schematic No.	Ref. No.	Parts No.	Description	Schematic No.
2-1x	BH318691	Head Base Block Comp. GX-F90		2-12	ZS300626	Screw, Pan Head 2x2.5 (Camera Standard)	
2-2	ZG289236	Tape Guide Spring	CM-0005	2-13	HZ317355	Head Hunger	CU-0005
2-3	HZ309128	Tape Guide	CF-0006	2-14	ZS356804	Set Screw, Hexagon Socket 3x4 (Cup/P.)	
2-4	ZW273688	Nut M2.3 #1		2-15	ZS391408	Screw, Pan 2.3x12	
2-5	ZG313187	Coil Spring		2-16	ZG465636	Angle Adjust Spring	CG-0029
2-6	HE315742	Erase Head E-921	37-2-25	2-17	ZS356848	Screw, Pan 2.3x6	
2-7	ZS356681	Screw, Pan Head 2.3x5		2-18	ZS410231	Screw, Pan Head 2.6x5	
2-8	ZW270123	'E' Ring 4M	6-1-9	2-19	ZS391386	Screw, Pan Head 2.3x3	
2-9	ZG312946	Coil Spring		2-20	ZG312996	Coil Spring T1-4.0/0.4-14.0	
2-10	HZ317352	Head Hold Plate	CU-0002				
2-11	HR314483	REC/PB Head PR4-3					

3. SUB FRAME BLOCK

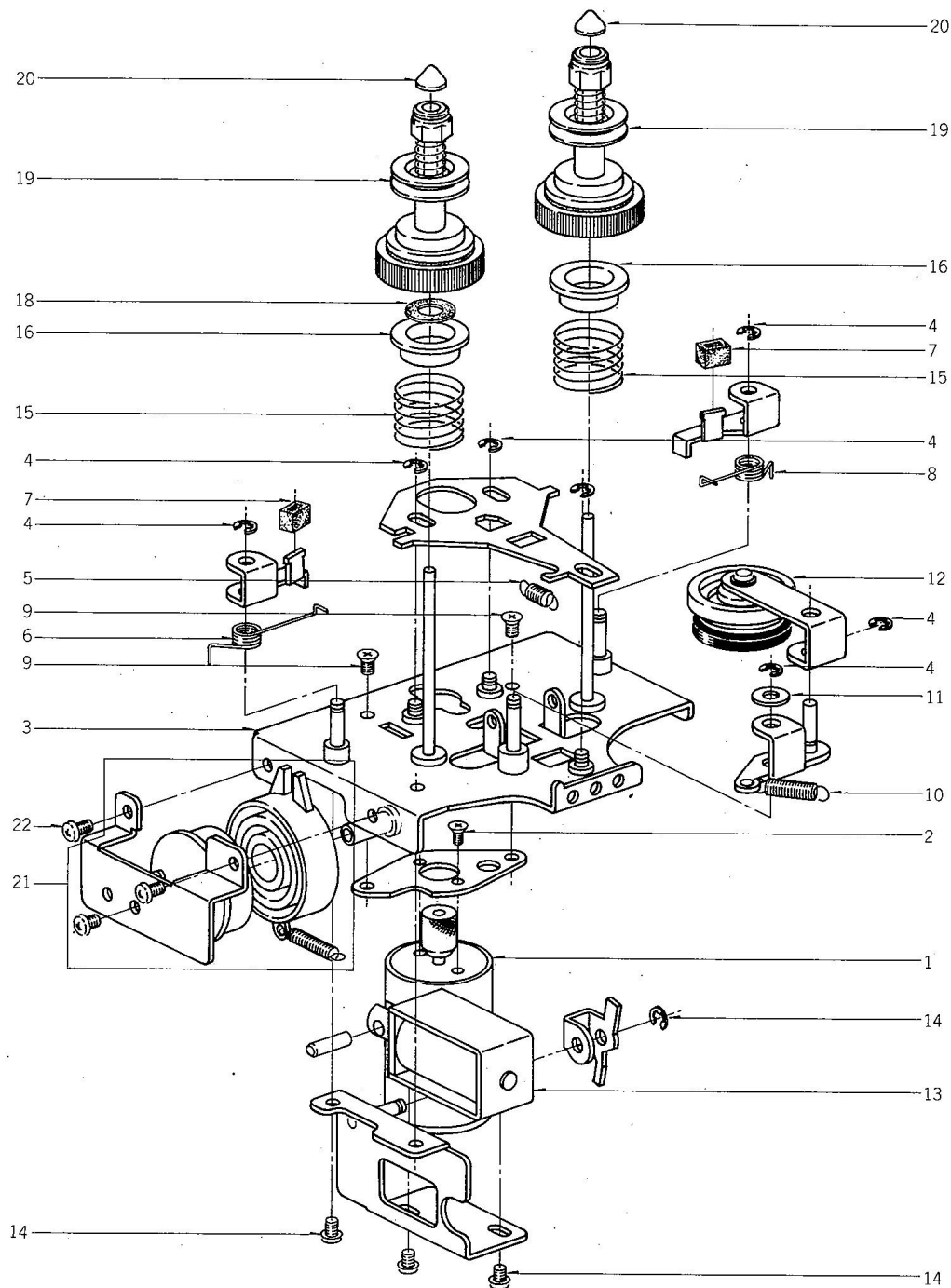

SUB FRAME BLOCK

Ref. No.	Parts No.	Description	Schematic No.	Ref. No.	Parts No.	Description	Schematic No.
REEL MOTOR BLOCK				3-12	MI321191	Idler Assy	9-3-59
3-1	BM318696	Reel Motor Block Comp. w/Pully GX-F90	CU-7016	3-13	EP317583	Plunger 0730THTI	44-1-116
3-2	ZS524812	Screw, Countersunk Head 2x4		3-14	ZS592378	Screw, Pan 2.6x3	
SUB FRAME BLOCK				3-15	ZG317413	Tension Spring	CU-2011
3-3	TC318783	Sub Frame Part	CU-2000B	3-16	TC317433	Torque Drum	CU-2010
3-4	ZW270088	'E' Ring 1.9M	6-1-9	3-17x	ZW322912	Oil Washer	CU-2013
3-5	ZG312943	Coil Spring		3-18	ZW474581	Washer (Teflon) D2.05x3.5x0.2t	
3-6	ZG317429	Brake Spring (L)	CU-2007	3-19	MT312122	Reel Table Part GXC-715D	13-2-41
3-7	MB282104	Brake Rubber	CN-1020	3-20	MT305793	Reel Cap	CF-2039
3-9	ZS477887	Screw, Countersunk Head 2.6x5		3-21	TC318694	Pause Damper Assy GX-F90	CU-2001B
3-10	ZG321595	Idler Clamp Spring	CU-2014	3-22	ZS432843	Screw, Pan 2.6x4	
3-11	ZW432753	Washer (PBP) D3.1x8x0.2t		3-23	ZW270088	'E' Ring 1.9M	6-1-9
				3-24	ZG317431	Brake Spring (R)	CU-2008

When ordering parts, please describe Parts Number, Description, and Model Number in detail.

4. MECHA ASSEMBLY BLOCK

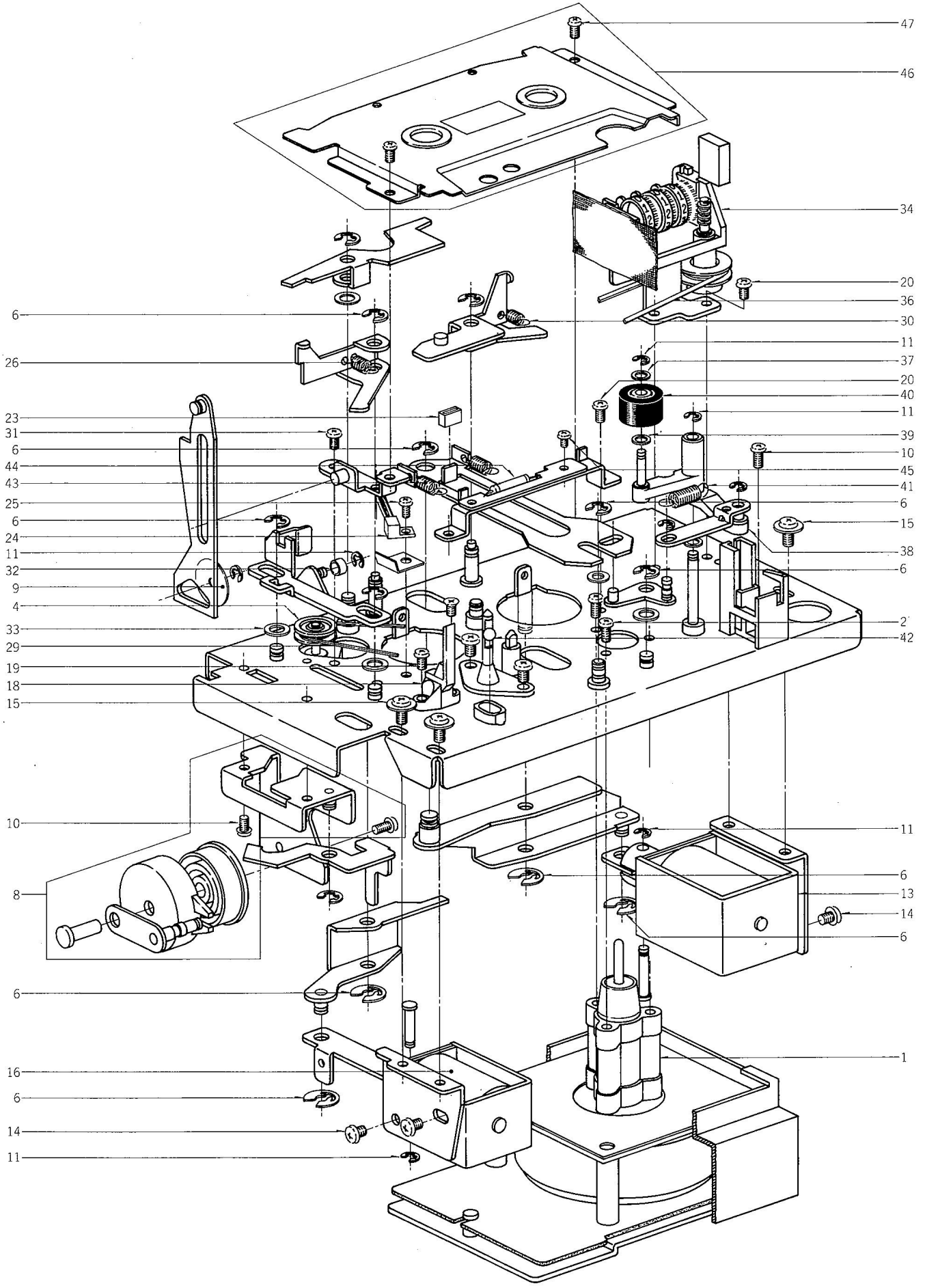

MECHA ASSEMBLY BLOCK

Ref. No.	Parts No.	Description	Schematic No.
MOTOR BLOCK			
4-1	BM318690	Motor Block Comp.	
4-2	ZS432843	Screw, Pan 2.6x4	
MECHA ASSEMBLY BLOCK			
4-3x	ZS325495	Tapping Screw, #2 BR 3x6	
4-4	ES302508	Revolution SW. HZR1006	25-9-5
4-5x	ZS608106	Screw, Pan 2x6	
4-6	ZW270101	'E' Ring 3M	6-1-9
4-7x	ZW282960	Washer D4.1x7x0.5t	
4-8	TC318681	Eject Damper Assy GX-F90	CU-1039B
4-9	ZW321703	Lock Plate Washer	CU-1059
4-10	ZS479474	Screw, Pan 2.6x5	
4-11	ZW270088	'E' Ring 1.9M	6-1-9
4-12x	ZW273756	Nut, #1 M3	
4-13	EP317571	Plunger 1240THTI	44-1-117
4-14	ZS324374	Screw, Pan 3x3.5 (Blue)	
4-15	ZS608321	Screw, Pan 3x6 W=8	
4-16	EP313498	Plunger 1037THTI	44-1-102
4-17x	ZS379350	Screw, Pan 3x6	
4-18	TC309145	Cassette Guide	CF-1015
4-19	ZS572242	Screw, Countersunk Head 2.6x6	
4-20	ZS432843	Screw, Pan 2.6x4	
4-21	ZW589893	Washer (PBP) D4.1x7x0.4t	
4-22x	ZW317555	Washer D3.1x6x0.25t Polyslider	
4-23	MB282104	Brake Rubber	CN-1020
4-24	ES317622	Leaf SW. BSW-47PB	25-10-40
4-25	ZS464703	Screw, Binding Head 2x4	
4-26	ZG310531	Coil Spring	
4-27x	BZ318685	EH Pad Assy GX-F90	CU-1063
4-28x	ZS417216	Screw, Pan 3x4	
4-29	MB317388	Revolution SW. Belt	CU-1031
4-30	ZG312943	Coil Spring	
4-31	ZS592378	Screw, Pan 2.6x3	
4-32	MR320323	Lock Roller	CU-1069
4-33	ZW324836	Washer (PBP) D4.1x7x0.15t PBP	
4-34	MC318792	Counter Part GX-F90	9-1-83
4-35x	MC318793	Counter (BL) GX-F90-BL	9-1-84
4-36	MB317387	Counter Belt	CU-1030
4-37	ZW259661	Washer (Polyslider) D3x5x0.25t	
4-38	ML318775	Pinch Roller Lever Part GX-F90	CU-1018B
4-39	ZW259661	Washer (Polyslider) D3x5x0.25t	
4-40	MP319580	Pinch Roller Part GX-F90	CU-1056
4-41	ZG317414	Pinch Roller Spring	CU-1055
4-42	MV269965	Steel Ball D4	
4-43	ZG317411	Head Clamp Spring	CU-1053
4-44	EL317599	Lamp (Lead Type) 6.3V 100MA	28-2-80
4-45	ZS477876	Screw, Pan 2x3	
4-46	TC318680	Decoration Plate Assy GX-F90	CU-1067
4-47	ZS375107	Screw, Pan Head 2.6x4	

5. EJECTOR BLOCK

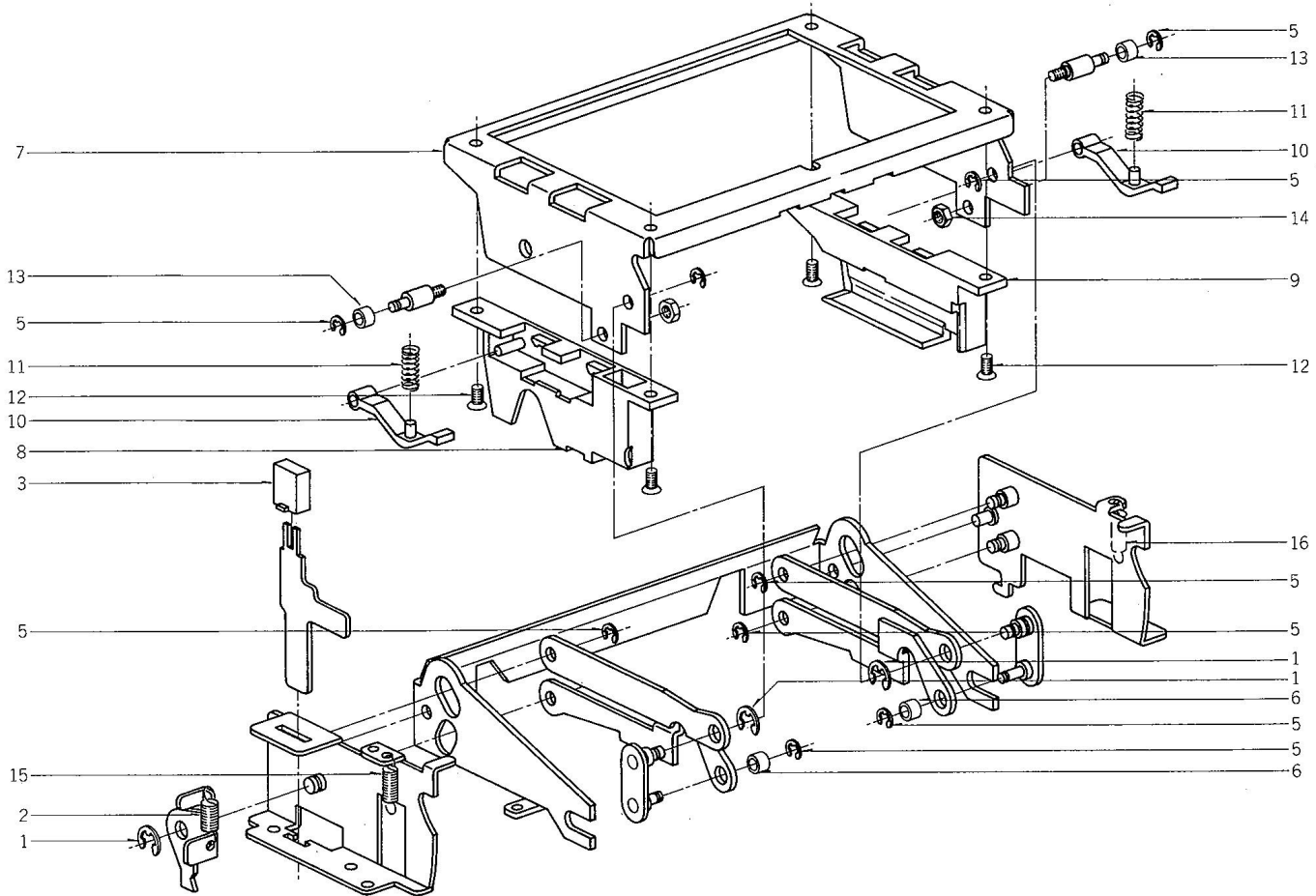

EJECTOR BLOCK

Ref. No.	Parts No.	Description	Schematic No.
5-1	ZW270101	'E' Ring 3M	6-1-9
5-2	ZG312944	Coil Spring	
5-3	SB317448	Button (C)	CU-3012
5-4x	SB317449	Button (C-BL)	CU-3012
5-5	ZW270088	'E' Ring 1.9M	6-1-9
5-6	MH318543	Stop Coller	CU-3021
5-7	TC317451	Lid Frame	CU-3014
5-8	TC317454	Cassette Holder (A)	CU-3016
5-9	TC317455	Cassette Holder (B)	CU-3017
5-10	TC309206	Setting Shoe	CF-1072
5-11	ZG313165	Coil Spring	
5-12	ZS477887	Screw, Countersunk Head 2.6x5	
5-13	MR203804	Roller	CB-1056
5-14	ZW357658	Nut M2.6	
5-15	ZG312996	Coil Spring T1-4.0/0.4-14.0	
5-16	ZG312945	Coil Spring	

6. SYS. CON P.C BOARD (CU-5032A) BLOCK

Symbol No.	Parts No.	Description	Schematic No.	Symbol No.	Parts No.	Description	Schematic No.
6-1	BA318724	Sys. Con P.C Board Comp. GX-F90	CU-5032A	6-D31to35	ED316143	Silicon Diode 1S2473-HS	45-3-53
6-IC1to3	EI430661	IC M53200P	45-8-38	6-D36,37	ED318292	Silicon Diode 1S2473T-77	45-3-59
6-IC4to6	EI322490	IC HD7401P	45-8-409	6-D38,39	ED322299	Silicon Diode 10D1-FA-2	45-3-61
6-IC7	EI634083	IC SN7402N	45-8-141	6-D40	ED318292	Silicon Diode 1S2473T-77	45-3-59
6-IC8	EI317654	IC HD7432P	45-8-385	6-D41,42	ED322299	Silicon Diode 10D1-FA-2	45-3-61
6-IC9	EI634140	IC SN74107N	45-8-147	6-D43,44	ED318292	Silicon Diode 1S2473T-77	45-3-59
6-IC10	EI250740	IC MSM4001	45-8-214	6-D45	ED316143	Silicon Diode 1S2473-HS	45-3-53
6-IC11	EI250738	IC MSM4011	45-8-211	6-D46to48	ED318292	Silicon Diode 1S2473T-77	45-3-59
6-IC12	EI317659	IC MSM4075	45-8-372	6-D49,50	ED322299	Silicon Diode 10D1-FA-2	45-3-61
6-IC13	EI308936	IC M54410P	45-8-304	6-D52	ED308953	Germanium Diode 1K34A-LH	45-3-46
6-IC14	EI213390	IC NJM4558D	45-8-191	6-D53,54	ED316143	Silicon Diode 1S2473-HS	45-3-53
6-IC15	EI317652	IC μ PC629C	45-8-373	6-D55to58	ED318292	Silicon Diode 1S2473T-77	45-3-59
6-IC16	EI317653	IC μ PD4066	45-8-374	6-D59	ED560913	Silicon Diode 1S2473-VE	45-3-23
6-TR1to8	ET639437	Transistor 2SC945L(Q)(P)	45-1-85	6-D60	ED308953	Germanium Diode 1K34A-LH	45-3-46
6-TR9	ET242684	Transistor 2SC1312S(H)	45-1-182	6-D61	ED316143	Silicon Diode 1S2473-HS	45-3-53
6-TR10,11	ET639437	Transistor 2SC945L(Q)(P)	45-1-85	6-D62to64	ED318292	Silicon Diode 1S2473T-77	45-3-59
6-TR12,13	ET554657	Transistor 2SA733(P)(Q)	45-1-124	6-D65	ED560913	Silicon Diode 1S2473-VE	45-3-23
6-TR14,15	ET639437	Transistor 2SC945L(Q)(P)	45-1-85	6-D66	ED316143	Silicon Diode 1S2473-HS	45-3-53
6-TR16	ET308937	Transistor 2SC2130(G)(H)	45-1-317	6-J1	EJ312374	Sub Magnale Socket 9P	31-1-240
6-TR17to20	ET639437	Transistor 2SC945L(Q)(P)	45-1-85	6-J901	EJ322405	8P Connector Assy	26-6-368
6-TR21,22	ET554657	Transistor 2SA733(P)(Q)	45-1-124	6-J902	EJ322406	9P Connector Assy	26-6-369
6-TR23to26	ET639437	Transistor 2SC945L(Q)(P)	45-1-85	6-VR1,2	EV464231	Semi-Fixed/Vol. V8K4-1 100kB	36-10-266
6-TR27	ET638504	Transistor 2SC945L(P)	45-1-85	6-VR3,4	EV300270	Semi-Fixed/Vol. V8K4-1 B300K	36-10-266
6-TR28	ET539133	Transistor 2SA733(P)	45-1-124	6-TH1,2	ED317669	Thermister TD5-C310D	45-5-30
6-TR29,30	ET638504	Transistor 2SC945L(P)	45-1-85	6-R12,13	ER309419	Metal Oxide Film/R. F 1W 1K(J)	35-19-1
6-TR31	ET539133	Transistor 2SA733(P)	45-1-124	6-R156,157	ER317684	Metal Oxide Film/R. 1/4W 910 ohms(F)	35-17-20
6-TR32	ET638504	Transistor 2SC945L(P)	45-1-85	6-R206	ER32265	Cement/R. (Wire Wound) 5W 13 ohms(J)	35-16-85
6-TR33to35	ET639437	Transistor 2SC945L(Q)(P)	45-1-85	6-C75	EC306419	Styrol/C. 680PF(J) 50WV	24-11-14
6-TR36	ET638504	Transistor 2SC945L(P)	45-1-85				
6-TR37	ET554657	Transistor 2SA733(P)(Q)	45-1-124				
6-TR38	ET638504	Transistor 2SC945L(P)	45-1-85				
6-TR39	ET307349	Transistor 2SD794(P)(Q)	45-1-334				
6-TR40,41	ET317688	Transistor 2SB564(K)	45-1-370				
6-TR42to44	ET317689	Transistor 2SD471(K)	45-1-283				
6-TR45to47	ET639437	Transistor 2SC945L(Q)(P)	45-1-85				
6-TR48	ET666404	Transistor 2SD571(K)(L)	45-1-218				
6-TR49	ET666415	Transistor 2SB605(K)(L)	45-1-225				
6-TR50	ET308937	Transistor 2SC2130(G)(H)	45-1-317				
6-TR51	ET666415	Transistor 2SB605(K)(L)	45-1-225				
6-TR52	ET308937	Transistor 2SC2130(G)(H)	45-1-317				
6-TR53	ET666404	Transistor 2SD571(K)(L)	45-1-218				
6-TR54,55	ET308937	Transistor 2SC2130(G)(H)	45-1-317				
6-TR56	ET666404	Transistor 2SD571(K)(L)	45-1-218				
6-TR57	ET666415	Transistor 2SB605(K)(L)	45-1-225				
6-TR58	ET554657	Transistor 2SA733(P)(Q)	45-1-124				
6-TR59	ET639437	Transistor 2SC945L(Q)(P)	45-1-85				
6-D1,2	ED308953	Germanium Diode 1K34A-LH	45-3-46				
6-D3	ED318292	Silicon Diode 1S2473T-77	45-3-59				
6-D4,5	ED308953	Germanium Diode 1K34A-LH	45-3-46				
6-D6	ED318292	Silicon Diode 1S2473T-77	45-3-59				
6-D7	ED316143	Silicon Diode 1S2473-HS	45-3-53				
6-D8,9	ED318292	Silicon Diode 1S2473T-77	45-3-59				
6-D10to15	ED316143	Silicon Diode 1S2473-HS	45-3-53				
6-D16	ED308953	Germanium Diode 1K34A-LH	45-3-46				
6-D16	ED316143	Silicon Diode 1S2473-HS	45-3-53				
6-D18	ED318292	Silicon Diode 1S2473T-77	45-3-59				
6-D19	ED316143	Silicon Diode 1S2473-HS	45-3-53				
6-D21	ED560913	Silicon Diode 1S2473-VE	45-3-23				
6-D22	ED308953	Germanium Diode 1K34A-LH	45-3-46				
6-D23	ED318292	Silicon Diode 1S2473T-77	45-3-59				
6-D24	ED316143	Silicon Diode 1S2473-HS	45-3-53				
6-D25	ED318292	Silicon Diode 1S2473T-77	45-3-59				
6-D26	ED308953	Germanium Diode 1K34A-LH	45-3-46				
6-D28	ED308953	Germanium Diode 1K34A-LH	45-3-46				
6-D29	ED318292	Silicon Diode 1S2473T-77	45-3-59				
6-D30	ED322410	Zener Diode RD-9.1E(B3)	45-6-72				

7. PRE AMP P.C BOARD (CU-5033) BLOCK

Symbol No.	Parts No.	Description	Schematic No.
7-1	BA318713	Pre Amp P.C Board Comp. GX-F90 (U/T)	CU-5033
7-2	BA318714	Pre Amp P.C Board Comp. GX-F90 (JPN) (AAL, JPN)	
7-IC1,2	EI301463	IC CR-713B	45-8-225
7-IC3	EI306141	IC LA4170	45-8-305
7-TR1	ET563905	Transistor 2SC711(G)(H)	45-1-67
7-TR2	ET317418	Transistor 2SA628(G)(H)	45-1-94
7-TR3	ET429748	Transistor 2SC711(H)	45-1-67
7-TR4,5	ET309334	Transistor 2SC458(C)(D)	45-1-26
7-TR6,7	ET639437	Transistor 2SC945L(Q)(P)	45-1-85
7-TR8	ET302466	FET 2SK68A(Special)	45-12-17
7-TR9	ET302456	Transistor 2SA906(G)(H)	45-1-280
7-TR10	ET391768	Transistor	
7-TR11	ET603257	Transistor 2SC458LG(C)(D)	45-1-29
7-TR12	ET309334	Transistor 2SC458(C)(D)	45-1-26
7-TR13,14	ET563905	Transistor 2SC711(G)(H)	45-1-67
7-TR15	ET317603	FET 2SK68(N)	45-12-14
7-TR16	ET309334	Transistor 2SC458(C)(D)	45-1-26
7-TR17	ET301249	Transistor 2SC1846(Q)(R)	45-1-267
7-TR18to20	ET429748	Transistor 2SC711(H)	45-1-67
7-D1	ED219464	Germanium Diode 1N34A	45-3-1
7-D2to5	ED560913	Silicon Diode 1S2473-VE	45-3-23
7-D6	ED316143	Silicon Diode 1S2473-HS	45-3-53
7-D7	ED219464	Germanium Diode 1N34A	45-3-1
7-D8,9	ED316143	Silicon Diode 1S2473-HS	45-3-53
7-D10	ED219464	Germanium Diode 1N34A	45-3-1
7-D11,12	ED560913	Silicon Diode 1S2473-VE	45-3-23
7-D13	ED624903	Silicon Diode 1S2473	45-3-28
7-D14	ED560913	Silicon Diode 1S2473-VE	45-3-23
7-D15,16	ED624903	Silicon Diode 1S2473	45-3-28
7-VC1,2	EC315346	Trimmer/C. ECV-1ZW 50x32E	24-2-48
7-SW1,2	ES317605	Push SW. SUF	25-5-338
7-SW3	ES317606	Push SW. SUF	25-5-339
7-SW4	ES317563	Rotary SW. SRZW	25-6-181
7-J2	EJ305629	Headphone Jack JL3A	31-2-90
7-VR1	EV305639	Semi-Fixed/Vol. D8 Axial Type 20 kΩ	36-10-273
7-VR2	EV305636	Semi-Fixed/Vol. D8 Axial Type 50 kΩ	36-10-273
7-VR3to5	EV305635	Semi-Fixed/Vol. D8 Axial Type 5 kΩ	36-10-273
7-VR6	EV305637	Semi-Fixed/Vol. D8 Axial Type 10 kΩ	36-10-273
7-VR7	EV317607	Single-Axial 2-Throw/Vol. GM80R 10kΩx2	36-22-49
7-RL1	EP308973	Relay LAB2NS DC24V	47-2-30
7-L1	EO302464	Inductor RX-9P 33MH(J)	23-1-275
7-L2	EO310608	Ferri Inductor FE-001 3.3MH	23-1-304
7-T1	EO301466	OSC. Coil 28N-503	23-4-46
7-FL1	ER309120	Dolby Filter D07-003	53-1-143
7-FL2	ER309119	Dolby Filter D07-001	53-1-143
7-FL3,4	EO315758	Trap Coil 100S-431	23-1-331
7-FL5	ER309120	Dolby Filter D07-003	53-1-143
7-R111	ER306962	Metal Oxide Film/R. (Homing Type) 2W 360 ohms(J)	35-11-22
7-C11	EC317420	Solid Aluminum/C. 0.1μF	24-19-3
7-C12	EC317668	Solid Aluminum/C. 0.33μF(K) 10WV	24-19-3
7-C16	EC317699	Solid Aluminum/C. 0.47μF(K) 10WV	24-19-3
7-C19	EC317699	Solid Aluminum/C. 0.47μF(K) 10WV	24-19-3
7-C20	EC317668	Solid Aluminum/C. 0.33μF(K) 10WV	24-19-3
7-C21	EC317611	Solid Aluminum/C. 0.22μF(K) 10WV	24-19-3

Symbol No.	Parts No.	Description	Schematic No.
7-C34,35	EC317624	Solid Aluminum/C. 0.1μF(M) 25WV	24-19-3
7-C46	EC317691	Styrol/C. 1300PF(J) 250V	24-11-17
7-C47	EC306438	Styrol/C. (Homing Type) 100PF(J) 50WV	24-11-14
7-C48	EC317692	Elect./C. (LL) 100μF(M) 25WV	24-20-19
7-C50	EC313868	Elect./C. (LL, Homing) 10μF(M) 16WV	24-20-19
7-C52	EC317693	Elect./C. (LL) 47μF(M) 25WV	24-20-19
7-C59	EC313825	Solid Aluminum/C. (Homing) 0.33μF(K) 25WV	24-19-3
7-C70	EC317420	Solid Aluminum/C. 0.1μF	24-19-3
7-C71	EC317668	Solid Aluminum/C. 0.33μF(K) 10WV	24-19-3
7-C87	EC317695	Elect./C. (LL) 4.7μF(M) 25WV	24-20-19
7-C88	EC317696	Elect./C. (LL) 10μF(M) 25WV	24-20-19
7-C97	EC306988	Styrol/C. 330PF(J) 50WV	24-11-14
7-3	EJ318709	Pin Jack Assy (U/T, CSA, CEE, UK, SAA)	
7-4	EJ318710	Pin Jack Assy (AAL, JPN)	
7-5	ZW263946	Nylon Rivet 4x5	2-7-57
7-6	ZS325495	Tapping Screw, #2 BR 3x6	

8. POWER SUPPLY P.C BOARD (CU-5030) BLOCK

Symbol No.	Parts No.	Description	Schematic No.
8-1	BA318731	Power Supply P.C Board Comp. GX-F90 (U/T) (U/T, CEE, UK, SAA)	CU-5030
8-2	BA318732	Power Supply P.C Board Comp. GX-F90 (JPN)	CU-5030
8-3	BA318733	Power Supply P.C Board Comp. GX-F90 (CSA)	CU-5030
8-4	BA314206	Power Supply P.C Board Comp. GX-F90 (AAL)	CU-5030
8-TR1	ET317331	Transistor 2SD234(R)(O) 2-10-B	45-1-81
8-TR2,3	ET320296	Transistor 2SD837(P)(Q)	45-1-389
8-TR4	ET639437	Transistor 2SC945L(Q)(P)	45-1-85
8-TR5	ET554657	Transistor 2SA733(P)(Q)	45-1-124
8-TR6	ET639437	Transistor 2SC945L(Q)(P)	45-1-85
8-D1	ED560913	Silicon Diode 1S2473-VE	45-3-23
8-D2	ED308945	Silicon Diode SVB10-100	45-2-82
8-D3	ED313623	Zener Diode HZ22-3	45-6-80
8-D4	ED309357	Silicon Diode SVB1 5-100	45-2-83
8-D5	ED306983	Zener Diode HZ12C-3	45-6-80
8-D6	ED319463	Silicon Stack 4B4B41-100	45-2-107
8-D7	ED313566	Silicon Diode GP-25G	45-2-91
8-D8	ED319167	Zener Diode HZ6C-3	45-6-80
8-D9	ED321180	Zener Diode HZ-98-2	45-6-80
8-D10	ED560913	Silicon Diode 1S2473-VE	45-3-23
8-D11	ED317594	Silicon Diode 1S2473-HL	45-3-60
8-D12,13	ED560913	Silicon Diode 1S2473-VE	45-3-23
8-J1	EJ310567	Δ Inlet, Board Type (U/T, CEE, UK, SAA)	31-1-234
8-VS1	ES315879	Δ Volt Change SW. HXW0144 (U/T, CEE, UK, SAA)	25-6-184

Symbol No.	Parts No.	Description	Schematic No.
8-SW1	ES665807	△ Push SW. SDG5P-E 5A/80A 250V (U/T, CEE, UK, SAA)	25-5-182
8-SW1	ES315159	△ Push SW. SDG1P(JPN)	25-5-330
8-SW1	ES655806	△ Push SW. SDG1P-J TV3 CSA	25-5-187
8-SW1	ES665875	△ Push SW. SDG1P-J TV-3 UL/CSA (AAL)	25-5-199
8-C1	EC301320	△ MP/C. 4700PF(M) 250WV (U/T, CEE, UK, SAA)	24-9-122
8-C1	EC321302	△ Ceramic/C. E 0.01μF(Z) 250VAC(JPN)	24-5-90
8-C1	EC314688	△ Ceramic/C. DE7150 FZ 0.01μF(P) 125WV (CSA)	24-5-87
8-C2	EC301320	△ MP/C. 4700PF(M) 250WV (U/T, CEE, UK, SAA)	24-9-122
8-C4	EC322281	Elect./C. (Vert.) 4700μF 50WV	24-12-17
8-C8	EC322419	Elect./C. (Vert.) 3300μF 25WV	24-12-46
8-C12	EC322803	Elect./C. (Vert.) 4700μF 16WV	24-12-46
8-C14	EC315968	Elect./C. (Vert.) 1000μF 6.3WV	24-12-46
8-5	ZS308895	S-Tight Screw, Pan 3x8	
8-6	ZS306021	S-Tight Screw, Pan 3x6	
8-7	ZS422076	Screw, Pan 3x5	
8-8	ZS421806	Screw, Pan 3x8	
8-9	ZW273756	Nut, #1 M3	
8-10	ZS447840	Tapping Screw, #2 BR 3x8	

9. SERVO P.C BOARD (CU-5031) BLOCK

Symbol No.	Parts No.	Description	Schematic No.
9-1	BA318717	Servo P.C Board Comp. GX-F90	CU-5031
9-IC1	EI317581	IC μA7392PC	45-8-379
9-TR1to3	ET639437	Transistor 2SC945L(Q)(P)	45-1-85
9-TR4	ET554657	Transistor 2SA733(P)(Q)	45-1-124
9-TR5	ET639437	Transistor 2SC945L(Q)(P)	45-1-85
9-TR6	ET307349	Transistor 2SD794(P)(Q)	45-1-334
9-D1	ED316143	Silicon Diode 1S2473-HS	45-3-53
9-VR1	EV317580	Semi-Fixed/Vol. (Metallized Film) TM8K(PV) 2kB	36-28-10
9-R6	ER317658	Metal Oxide Film/R. 1/4WS 100K(F)	35-17-20
9-C3,4	EC657066	Solid Aluminum/C. (Vert. Type) 0.15μF(M) 25WV	24-19-2
9-C5	EC317620	Polypropylene Film/C. 0.047μF(J) 50WV	24-22-7
9-C6	EC317623	Styrol/C. 1000PF(J) 50WV	24-11-14
9-C7	EC523282	Solid Aluminum/C. (Vert. Type) 0.1μF(M) 25WV	24-19-2
9-2	ZS306021	S-Tight Screw, Pan 3x6	
9-3	ZS447840	Tapping Screw, #2 BR 3x8	

10. MIXING AMP P.C BOARD (CU-5036) BLOCK

Symbol No.	Parts No.	Description	Schematic No.
10-1	BA318736	Mixing Amp P.C Board Comp. GX-F90	CU-5036
10-TR1	ET391768	Transistor 2SC458LG(C)(D)	45-1-29
10-TR2	ET603257	Transistor 2SC1312S(G)(H)	45-1-182
10-TR3	ET242684	Transistor 2SC1312S(H)	45-1-182
10-J1	EJ315746	Mic Jack HLJ0278-01-030	31-2-107
10-VR1,2	EV317559	Double Axial 2-Throw/Vol. DM20R 100kAx2	36-18-19
10-C1	EC313868	Elect./C. (LL, Homing) 10μF(M) 16WV	24-20-19
10-C3	EC317692	Elect./C. (LL) 100μF(M) 25WV	24-20-19
10-C5	EC318407	Elect./C. (LL) 2.2μF(M) 50WV	24-20-19
10-C6	EC313868	Elect./C. (LL, Homing) 10μF(M) 16WV	24-20-19
10-2	ZS422076	Screw, Pan 3x5	
10-3	ZS325495	Tapping Screw, #2 BR 3x6	

11. MOTOR P.C BOARD (CU-7007) BLOCK

Symbol No.	Parts No.	Description	Schematic No.
11-IC1	EI301749	μPC741C	45-8-229
11-IC2	EI213390	IC NJM4558D	45-8-191
11-IC3to5	EI317567	Hole Element VHE610A	45-17-1
11-TR1	ET317565	Transistor 2SD471(L)(M)	45-1-283
11-TR2	ET317566	Transistor 2SB564(L)(M)	45-1-370
11-TR3	ET317565	Transistor 2SD471(L)(M)	45-1-283
11-TR4	ET317566	Transistor 2SB564(L)(M)	45-1-370
11-TR5	ET317565	Transistor 2SD471(L)(M)	45-1-283
11-TR6	ET317566	Transistor 2SB564(L)(M)	45-1-370

12. SWITCH P.C BOARD (CU-5032B) BLOCK

Symbol No.	Parts No.	Description	Schematic No.
12-SW1to3	ES317550	Push SW. SUF32	25-5-340
12-SW4	ES317551	Rotary SW. SRU1023N	25-6-182
12-VR1	EV522797	Semi-Fixed/Vol. V8K4-1 20K(B)	36-10-266

13. FINAL ASSEMBLY BLOCK (1)

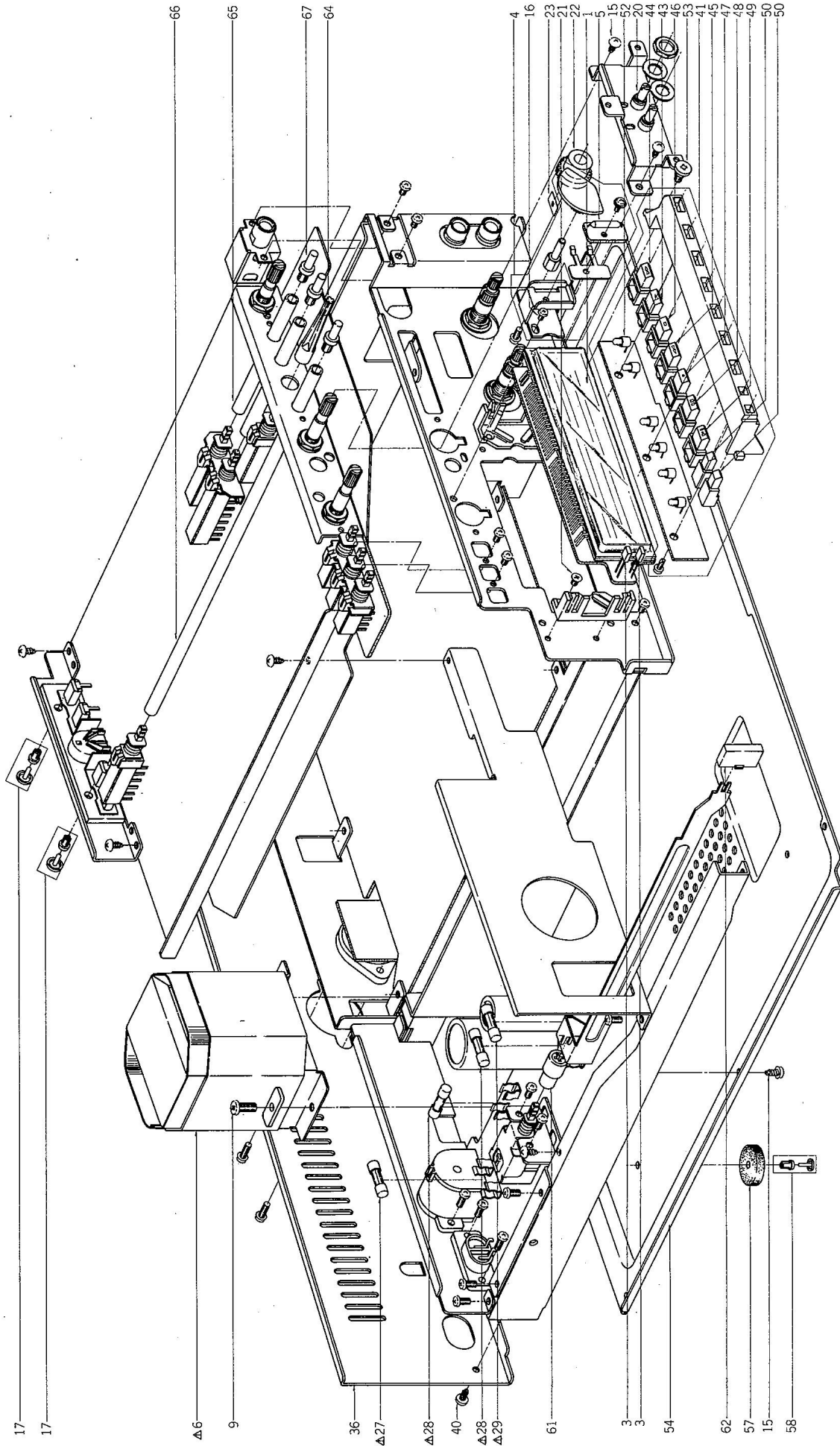

FINAL ASSEMBLY BLOCK (1)

Ref. No.	Parts No.	Description	Schematic No.
BAR METER P.C BOARD BLOCK			
13-1	EM317556	FL Display BG-49	53-1-179
13-2x	EI317557	IC MSA-803	45-8-371
13-3	ED326142	LED GL-9NG51	45-15-47
DIAL HOLDER BLOCK			
13-4	BZ318707	Dial Holder Block Comp. GX-F90	CU-5046
13-5	EL317599	Lamp (Lead Type) 6.3V 100mA	28-2-80
TRANS. BASE BLOCK			
13-6	BT317588	△ Power Trans. CUT-3 (U/T, CEE, UK, SAA)	38-4-767
13-7x	BT317585	△ Power Trans. CUT-1 (JPN)	38-4-765
13-8x	BT317587	△ Power Trans. CUT-2 (CSA, AAL)	38-4-766
13-9	ZS301576	S-Tight Screw, Pan 4x10	
13-10x	EW306427	△ AC Cord (JPN)	26-3-63
13-11x	EW305691	△ AC Cord CUL (CSA, AAL)	26-3-65
13-12x	EZ631945	Strain Relief SR-4N-4 (JPN, CSA, AAL)	2-7-49
AMP ASSEMBLY BLOCK			
13-13	ZS306021	S-Tight Screw, Pan 3x6	
13-14	ZS447840	Tapping Screw, #2 BR 3x8	
13-15	ZS325495	Tapping Screw, #2 BR 3x6	
13-16	ZS422076	Screw, Pan 3x5	
13-17	ZW241200	Nylon Rivet (NRB) 3x8 (Black)	2-7-54
13-18	ZS297641	Tapping Screw #2, 3x8 (Bind) W=10	
13-19	ZS379350	Screw, Pan 3x6	
13-20	EV317558	Vol. (Center Click) 10kB	36-7-16
13-21	ZS430413	Screw, Countersunk Head 2.6x4	
13-22	TC317472	Gear	CU-5014
13-23	ZG317487	Plate Spring	CU-5028
13-24	ZS417216	Screw, Pan 3x4	
13-25	ZS421740	Screw, Pan 3x8 (Black)	
13-26	ZS306021	S-Tight Screw, Pan 3x6	
13-27	EF623103	△ Fuse (Semko T Type) 1AT (U/T, CEE, UK, SAA)	39-1-53
13-28	EF602550	△ Fuse (Semko T Type) 1.25AT 250V (U/T, CEE, UK, SAA)	39-1-53
13-29	EF601964	△ Fuse (Semko T Type) 1.6AT (U/T, CEE, UK, SAA)	39-1-53
13-30x	EF306949	△ Fuse 1.25A 250V (JPN)	39-1-64
13-31x	EF306949	△ Fuse 1.25A 250V (JPN)	39-1-64
13-32x	EF311839	△ Fuse 1.6A 250V (JPN)	39-1-64
13-33x	EF309392	△ Fuse 1.25A 125V (CSA, AAL)	39-1-65
13-34x	EF309392	△ Fuse 1.25A 125V (CSA, AAL)	39-1-65
13-35x	EF308847	△ Fuse 1.6A 125V (CSA, AAL)	39-1-65
13-36	SP317504	Rear Panel (U, E, B) (U/T, CEE, UK, SAA)	CU-6000
13-37x	SP317505	Rear Panel (J) (JPN)	CU-6002
13-38x	SP317502	Rear Panel (C) (CSA)	CU-6001
13-39x	SP317503	Rear Panel (A) (AAL)	CU-6001
13-40	ZS447761	Tapping Screw, #2 BR 3x6 (Black)	
13-41	BK318678	Operation Key Assy GX-F90	25-5-348
13-42x	BK318791	Operation Key Assy GX-F90-BL	25-5-349
13-43	SB317625	Operation Button (PB)	25-5-348
13-44	SB317626	Operation Button (FF)	25-5-348
13-45	SB317627	Operation Button (REW)	25-5-348
13-46	SB317628	Operation Button (STOP)	25-5-348
13-47	SB317629	Operation Button (REC)	25-5-348
13-48	SB317630	Operation Button (PAUSE)	25-5-348
13-49	SB317631	Operation Button (REC MUTE)	25-5-348
13-50	SB317633	Operation Button	25-5-348
13-51x	SB317642	Operation Button (BL)	25-5-349
13-52	EL317634	Lamp	25-5-348
13-53	ZS317554	Tap-Tight Screw, Graduated 3x5	7-1-73
13-54	SP317477	Bottom Plate	CU-5019

Ref. No.	Parts No.	Description	Schematic No.
13-55x	ZS200676	Tapping Screw, #2 Countersunk 3x6	
13-56x	ZS472274	Tapping Screw, #2 3x6 (Bind)	
13-57	SA313811	Rubber Foot	CY-6046
13-58	ZW302909	Nylon Rivet (NRB) (FNPR) 3x3.5 (BLK)	2-7-54
FINAL ASSEMBLY BLOCK			
13-59x	SP317544	Knob Panel	CU-6033,6034
13-60x	SP317545	Knob Panel (BL)	CU-6033,6034
13-61	TC289484	SW. Joint	CM-6015
13-62	SB316498	Button (B)	CU-6009
13-63x	SB316499	Button (B-BL)	CU-6009
13-64	TC304935	Push Rod	CN-5031
13-65	SP317544	Knob Panel	CU-6033,6034
13-66	SP317545	Knob Panel (BL)	CU-6033,6034
13-67	TC317486	Bar Top	CU-5027

14. FINAL ASSEMBLY BLOCK (2)

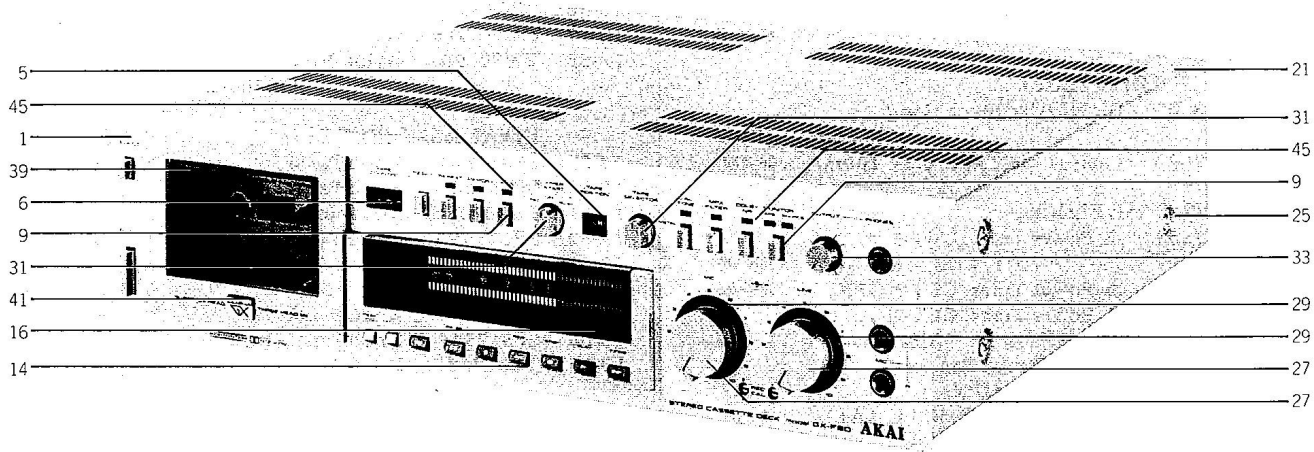

FINAL ASSEMBLY BLOCK (2)

Ref. No.	Parts No.	Description	Schematic No.	Ref. No.	Parts No.	Description	Schematic No.
FRONT PANEL BLOCK				14-25	ZS315878	S-Tight Screw, Bind 4x8	
14-1	BD318674	Front Panel Block Comp. GX-F90	CU-6045	14-26x	ZS447761	Tapping Screw, #2 BR 3x6 (Black)	
14-2x	BD318675	Front Panel Block Comp. GX-F90-BL	CU-6045	14-27	SK318794	Double Knob (Upper) Part GX-F90	CU-6031
14-3x	SE317512	Button Escatcheon (A)	CU-6006	14-28x	SK318795	Double Knob (Upper-BL) Part GX-F90-BL	CU-6031
14-4x	SE317513	Button Escatcheon (B)	CU-6007	14-29	SK317541	Double Knob (Lower)	CU-6032
14-5	SE317536	Tape Selector Escatcheon	CU-6028	14-30x	SK317543	Double Knob (Lower-BL)	CU-6032
14-6	SE317535	Counter Escatcheon	CU-6026	14-31	SK317523	Knob (A)	CU-6017
14-7x	SE317529	Eject Button Escatcheon	CU-6022	14-32x	SK317524	Knob (A-BL)	CU-6017
14-8x	SE316393	Power Button Escatcheon	CU-6010	14-33	SK317537	Knob (B)	CU-6030
14-9	SB316355	Button (A)	CU-6005	14-34x	SK317538	Knob (BL)	CU-6030
14-10x	SB316356	Button (A-BL)	CU-6005	14-35x	EW306152	△ AC Cord Set U/T Type 2 (U/T)	26-3-71
14-11x	ZG316392	Button Spring	CU-6008	14-36x	EW315767	△ AC Cord Set CEE 2 Cores (CEE)	26-3-72
14-12x	SZ317519	Filter	CU-6013,6014	14-37x	EW322400	△ AC Cord Set BASEC 2 Cores (UK)	26-3-73
14-13x	SP322819	Filter Cover	CU-6043	14-38x	EW322401	△ AC Cord Set SAA 2 Cores (SAA)	26-3-77
14-14	SE317521	Operation Escatcheon	CU-6015,6016	14-39	BD318672	Lid Panel Assy GX-F90	CU-6046
14-15x	SE317522	Operation Escatcheon (BL)	CU-6015,6016	14-40x	BD318673	Lid Panel Assy GX-F90-BL	CU-6046
14-16	SE317518	Meter Escatcheon	CU-6011,6012	14-41	SM315737	Super GX Name Plate	CF-6236
14-17x	ZW305006	Nylon Rivet 4x5	2-7-58	14-42x	SZ317672	Head Decoration Plate	CU-6038
FINAL ASSEMBLY BLOCK				14-43x	ZS608174	Screw, Pan 2.6x3	
14-18x	ZS447840	Tapping Screw, #2 BR 3x8		14-44x	ZW305013	Pop Rivet D3.2	7-6-9
14-19x	ZS325495	Tapping Screw, #2 BR 3x6		14-45	ED326142	LED GL-9NG51	45-15-47
14-20x	ZS666336	Tapping Screw, #2 3x8 (PAN)					
14-21	SP317530	Upper Cover (A)	CU-6023				
14-22x	SP317532	Upper Cover (B) (AAL)	CU-6023				
14-23x	SP317533	Upper Cover (BL)	CU-6023				
14-24x	ZS310588	S-Tight Screw, Bind 4x8 (Black) (AAL, BL)					

INDEX

Parts No.	Ref. No. & Symbol No.	Parts No.	Ref. No. & Symbol No.	Parts No.	Ref. No. & Symbol No.	Parts No.	Ref. No. & Symbol No.
BA314206	8-4	ED316143	6-D31to35	EL317599	13-5	ET639437	6-TR14,15
BA318713	7-1	ED316143	6-D45	EL317634	13-52	ET639437	6-TR17to20
BA318714	7-2	ED316143	6-D53,54	EM317556	13-1	ET639437	6-TR23to26
BA318717	9-1	ED316143	6-D61	EO301466	7-T1	ET639437	6-TR33to35
BA318724	6-1	ED316143	6-D66	EO302464	7-L1	ET639437	6-TR45to47
BA318731	8-1	ED316143	7-D6	EO310608	7-L2	ET639437	6-TR59
BA318732	8-2	ED316143	7-D8,9	EO315758	7-FL3,4	ET639437	7-TR6,7
BA318733	8-3	ED316143	9-D1	EP308973	7-RL1	ET639437	8-TR4
BA318736	10-1	ED317594	8-D11	EP313498	4-16	ET639437	8-TR6
BD318672	14-39	ED317669	6-TH1,2	EP317571	4-13	ET639437	9-TR1to3
BD318673	14-40x	ED318292	6-D3	EP317583	3-13	ET639437	9-TR5
BD318674	14-1	ED318292	6-D6	ER306962	7-R111	ET666404	6-TR48
BD318675	14-2x	ED318292	6-D8,9	ER309119	7-FL2	ET666404	6-TR53
BH318691	2-1x	ED318292	6-D18	ER309120	7-FL1	ET666404	6-TR56
BK318678	13-41	ED318292	6-D23	ER309120	7-FL5	ET666415	6-TR49
BK318791	13-42x	ED318292	6-D25	ER309419	6-R12,13	ET666415	6-TR51
BM318690	4-1	ED318292	6-D29	ER317658	9-R6	ET666415	6-TR57
BM318696	3-1	ED318292	6-D36,37	ER317684	6-R156,157	EV300270	6-VR3,4
BT317585	13-7x	ED318292	6-D40	ER322265	6-R206	EV305635	7-VR3to5
BT317587	13-8x	ED318292	6-D43,44	ES302508	4-4	EV305636	7-VR2
BT317588	13-6	ED318292	6-D46to48	ES315159	8-SW1	EV305637	7-VR6
BZ318685	4-27x	ED318292	6-D55to58	ES315879	8-VS1	EV305639	7-VR1
BZ318707	13-4	ED318292	6-D62to64	ES317550	12-SW1to3	EV317558	13-20
EC301320	8-C1	ED319167	8-D8	ES317551	12-SW4	EV317559	10-VR1,2
EC301320	8-C2	ED319463	8-D6	ES317563	7-SW4	EV317580	9-VR1
EC306419	6-C75	ED321180	8-D9	ES317605	7-SW1,2	EV317607	7-VR7
EC306438	7-C47	ED322299	6-D38,39	ES317606	7-SW3	EV317607	7-VR1,2
EC306988	7-C97	ED322299	6-D41,42	ES317622	4-24	EV464231	6-VR1,2
EC313825	7-C59	ED322299	6-D49,50	ES317622	4-24	EV522797	12-VR1
EC313868	7-C50	ED322410	6-D30	ES655806	8-SW1	EW305691	13-11x
EC313868	10-C1	ED326142	13-3	ES665807	8-SW1	EW306152	14-35x
EC313868	10-C6	ED326142	14-45	ES665875	8-SW1	EW306427	13-10x
EC314688	8-C1	ED560913	6-D21	ET242684	6-TR9	EW315767	14-36x
EC315346	7-VC1,2	ED560913	6-D59	ET242684	10-TR3	EW322400	14-37x
EC315968	8-C14	ED560913	6-D65	ET301249	7-TR17	EW322401	14-38x
EC317420	7-C11	ED560913	7-D2to5	ET302456	7-TR9	EZ631945	13-12x
EC317420	7-C70	ED560913	7-D11,12	ET302466	7-TR8	HE315742	2-6
EC317611	7-C21	ED560913	7-D14	ET307349	6-TR39	HR314483	2-11
EC317620	9-C5	ED560913	8-D1	ET307349	9-TR6	HZ309128	2-3
EC317623	9-C6	ED560913	8-D10	ET308937	6-TR16	HZ317352	2-10
EC317624	7-C34,35	ED560913	8-D12,13	ET308937	6-TR50	HZ317355	2-13
EC317668	7-C12	ED624903	7-D13	ET308937	6-TR52	MB282104	3-7
EC317668	7-C20	ED624903	7-D15,16	ET308937	6-TR54,55	MB282104	4-23
EC317668	7-C71	EF306949	13-30x	ET309334	7-TR4,5	MB317387	4-36
EC317691	7-C46	EF306949	13-31x	ET309334	7-TR12	MB317388	4-29
EC317692	7-C48	EF308847	13-35x	ET309334	7-TR16	MC318792	4-34
EC317692	10-C3	EF308847	13-35x	ET317331	8-TR1	MC318793	4-35x
EC317692	7-C52	EF309392	13-33x	ET317418	7-TR2	MH318543	5-6
EC317693	7-C87	EF309392	13-34x	ET317565	11-TR1	MI321191	3-12
EC317695	7-C88	EF311839	13-32x	ET317565	11-TR3	ML318775	4-38
EC317696	7-C16	EF601964	13-29	ET317565	11-TR5	MP319580	4-40
EC317699	7-C19	EF602550	13-28	ET317566	11-TR2	MR203804	5-13
EC318407	10-C5	EF623103	13-27	ET317566	11-TR4	MR320323	4-32
EC321302	8-C1	EI213390	6-IC14	ET317566	11-TR6	MT305793	3-20
EC322281	8-C4	EI213390	11-IC2	ET317603	7-TR15	MT312122	3-19
EC322419	8-C8	EI250738	6-IC11	ET317688	6-TR40,41	MV269965	4-42
EC322803	8-C12	EI250740	6-IC10	ET317689	6-TR42to44	SA313811	13-57
EC523282	9-C7	EI301463	7-IC1,2	ET320296	8-TR2,3	SB316355	14-9
EC657066	9-C3,4	EI301749	11-IC1	ET391768	7-TR10	SB316356	14-10x
ED219464	7-D1	EI306141	7-IC3	ET391768	10-TR1	SB316498	13-62
ED219464	7-D7	EI308936	6-IC13	ET429748	7-TR3	SB316499	13-63x
ED219464	7-D10	EI317557	13-2x	ET429748	7-TR18to20	SB317448	5-3
ED306983	8-D5	EI317567	11-IC3to5	ET539133	6-TR28	SB317449	5-4x
ED308945	8-D2	EI317581	9-IC1	ET539133	6-TR31	SB317625	13-43
ED308953	6-D1,2	EI317652	6-IC15	ET554657	6-TR12,13	SB317626	13-44
ED308953	6-D4,5	EI317653	6-IC16	ET554657	6-TR21,22	SB317627	13-45
ED308953	6-D16	EI317654	6-IC8	ET554657	6-TR37	SB317628	13-46
ED308953	6-D22	EI317659	6-IC12	ET554657	6-TR58	SB317629	13-47
ED308953	6-D26	EI322490	6-IC4to6	ET554657	8-TR5	SB317630	13-48
ED308953	6-D28	EI430661	6-IC1to3	ET554657	9-TR4	SB317631	13-49
ED308953	6-D52	EI634083	6-IC7	ET563905	7-TR1	SB317633	13-50
ED308953	6-D60	EI634140	6-IC9	ET563905	7-TR13,14	SB317642	13-51x
ED309357	8-D4	EJ305629	7-J2	ET603257	7-TR11	SE316393	14-8x
ED313566	8-D7	EJ310567	8-J1	ET603257	10-TR12	SE317512	14-3x
ED313623	8-D3	EJ312374	6-J1	ET638504	6-TR27	SE317513	14-4x
ED316143	6-D7	EJ315746	10-J1	ET638504	6-TR29,30	SE317518	14-16
ED316143	6-D10to15	EJ318709	7-3	ET638504	6-TR32	SE317521	14-14
ED316143	6-D16	EJ318710	7-4	ET638504	6-TR36	SE317522	14-15x
ED316143	6-D19	EJ322405	6-J901	ET638504	6-TR38	SE317529	14-7x
ED316143	6-D24	EJ322406	6-J902	ET639437	6-TR1to8	SE317535	14-6
		EL317599	4-44	ET639437	6-TR10,11	SE317536	14-5

INDEX

Parts No.	Ref. No. & Symbol No.	Parts No.	Ref. No. & Symbol No.	Parts No.	Ref. No. & Symbol No.	Parts No.	Ref. No. & Symbol No.
SK317523	14-31	ZS379350	4-17x				
SK317524	14-32x	ZS379350	13-19				
SK317537	14-33	ZS391386	2-19				
SK317538	14-34x	ZS391408	2-15				
SK317541	14-29	ZS410231	2-18				
SK317543	14-30x	ZS417216	4-28x				
SK318794	14-27	ZS417216	13-24				
SK318795	14-28x	ZS421740	13-25				
SM315737	14-41	ZS421806	8-8				
SP317477	13-54	ZS422076	8-7				
SP317502	13-38x	ZS422076	10-2				
SP317503	13-39x	ZS422076	13-16				
SP317504	13-36	ZS430413	13-21				
SP317505	13-37x	ZS432843	3-22				
SP317530	14-21	ZS432843	4-2				
SP317532	14-22x	ZS432843	4-20				
SP317533	14-23x	ZS447761	13-40				
SP317544	13-59x	ZS447761	14-26x				
SP317545	13-60x	ZS447840	8-10				
SP322819	14-13x	ZS447840	9-3				
SZ317519	14-12x	ZS447840	13-14				
SZ317672	14-42x	ZS447840	14-18x				
TC289484	13-61	ZS464703	4-25				
TC304935	13-64	ZS472274	13-56x				
TC309145	4-18	ZS477876	4-45				
TC309206	5-10	ZS477887	3-9				
TC317433	3-16	ZS477887	5-12				
TC317451	5-7	ZS479474	4-10				
TC317454	5-8	ZS524812	3-2				
TC317455	5-9	ZS572242	4-19				
TC317472	13-22	ZS592378	3-14				
TC317475	13-65	ZS592378	4-31				
TC317476	13-66	ZS608106	4-5x				
TC317486	13-67	ZS608174	14-43x				
TC318680	4-46	ZS608321	4-15				
TC318681	4-8	ZS666336	14-20x				
TC318694	3-21	ZW241200	13-17				
TC318783	3-3	ZW259661	4-37				
ZG289236	2-2	ZW259661	4-39				
ZG310531	4-26	ZW263946	7-5				
ZG312943	3-5	ZW270088	3-4				
ZG312943	4-30	ZW270088	3-23				
ZG312944	5-2	ZW270088	4-11				
ZG312945	5-16	ZW270088	5-5				
ZG312946	2-9	ZW270101	4-6				
ZG312996	2-20	ZW270101	5-1				
ZG312996	5-15	ZW270123	2-8				
ZG313165	5-11	ZW273688	2-4				
ZG313187	2-5	ZW273756	4-12x				
ZG316392	14-11x	ZW273756	8-9				
ZG317411	4-43	ZW282960	4-7x				
ZG317413	3-15	ZW302909	13-58				
ZG317414	4-41	ZW305006	14-17x				
ZG317429	3-6	ZW305013	14-44x				
ZG317431	3-24	ZW317555	4-22x				
ZG317487	13-23	ZW321703	4-9				
ZG321595	3-10	ZW322912	3-17x				
ZG465636	2-16	ZW324836	4-33				
ZS200676	13-55x	ZW357658	5-14				
ZS297641	13-18	ZW432753	3-11				
ZS300626	2-12	ZW474581	3-18				
ZS301576	13-9	ZW589893	4-21				
ZS306021	8-6						
ZS306021	9-2						
ZS306021	13-13						
ZS306021	13-26						
ZS308895	8-5						
ZS310588	14-24x						
ZS315878	14-25						
ZS317554	13-53						
ZS324374	4-14						
ZS325495	4-3x						
ZS325495	7-6						
ZS325495	10-3						
ZS325495	13-15						
ZS325495	14-19x						
ZS356681	2-7						
ZS356804	2-14						
ZS356848	2-17						
ZS375107	4-47						

SECTION 3

SCHEMATIC DIAGRAM

1. SCHEMATIC DIAGRAM OF ICs
2. GX-F90 NO. 2-1 1582442A POWER & SYS. CON SCHEMATIC DIAGRAM
3. GX-F90 NO. 2-2 1582443A AMP SCHEMATIC DIAGRAM

CR-713B

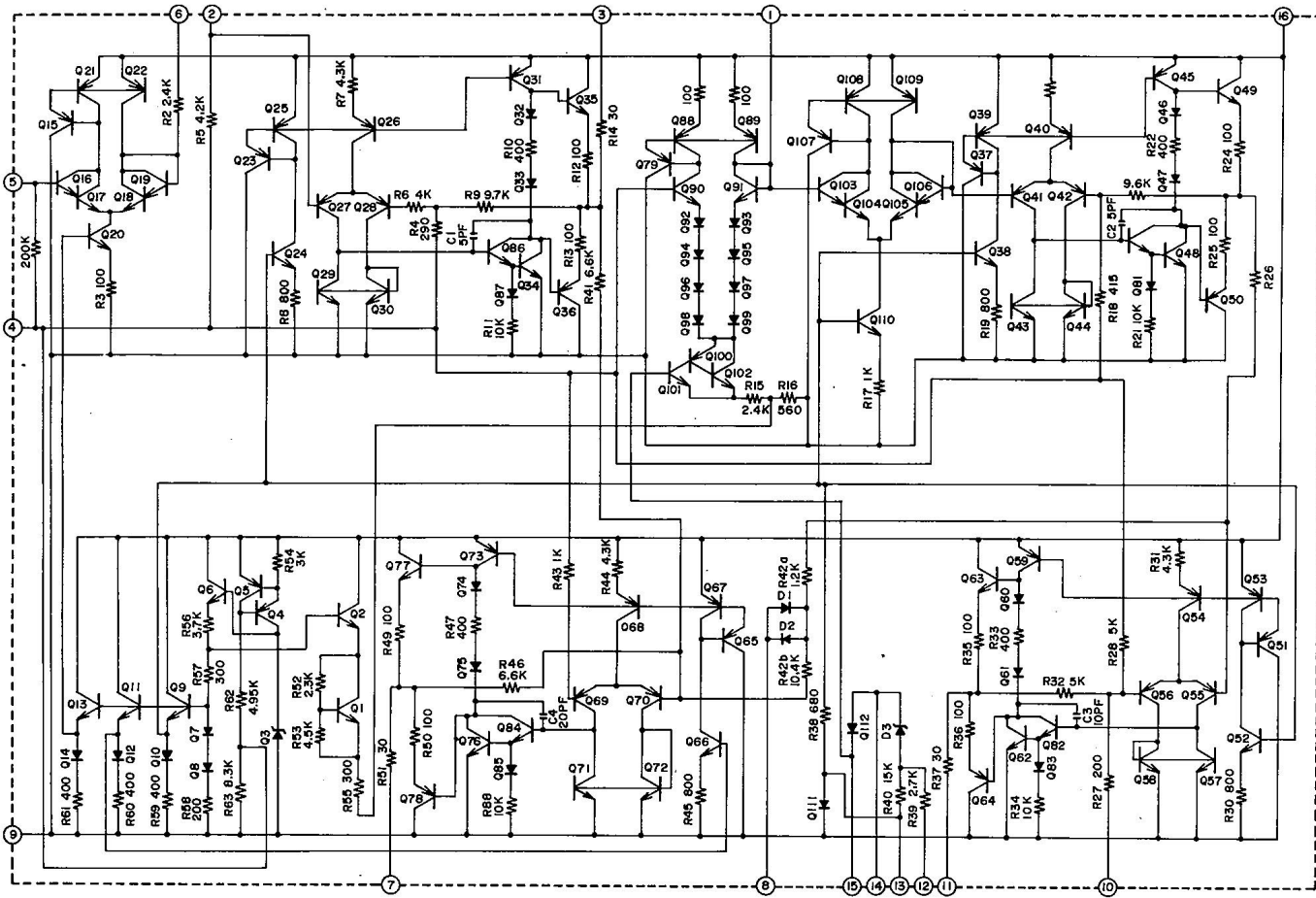

LA4170

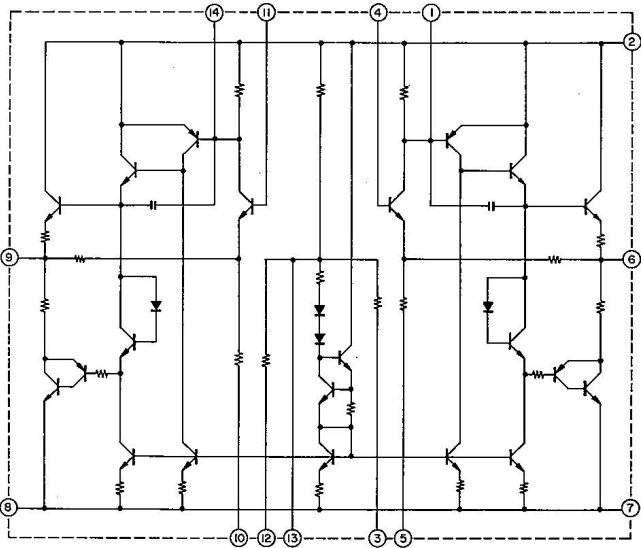

M54410P

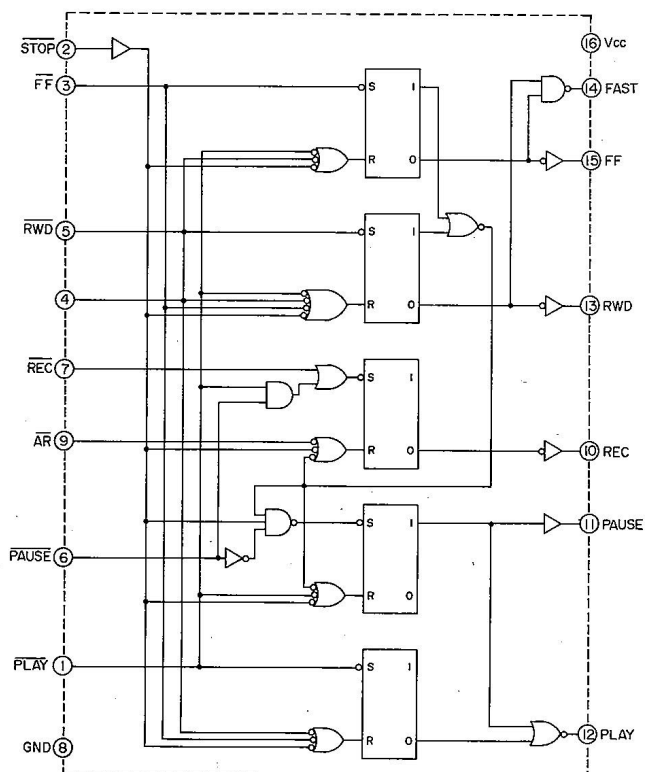

SN7400N

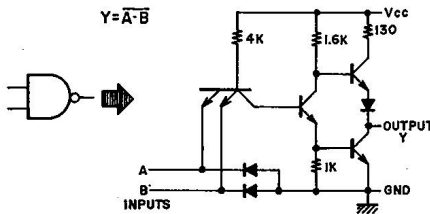
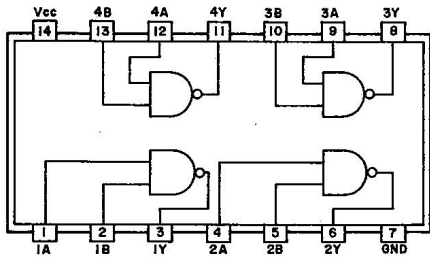

HD7432P

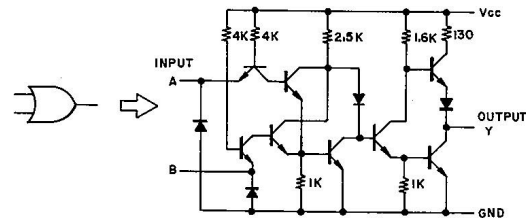
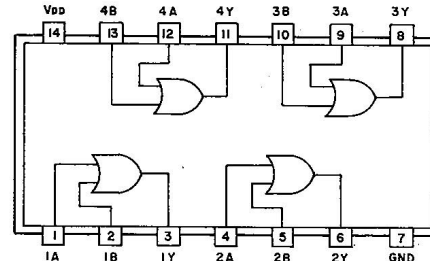

SN7401N

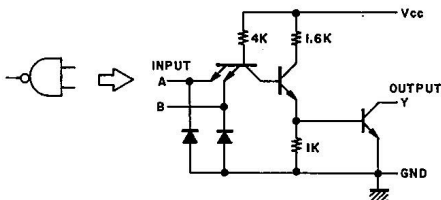
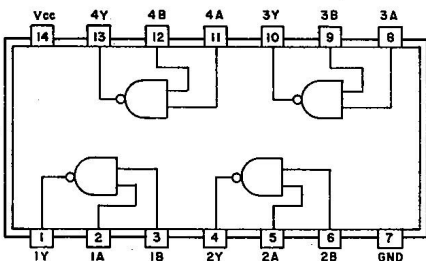

SN74107N

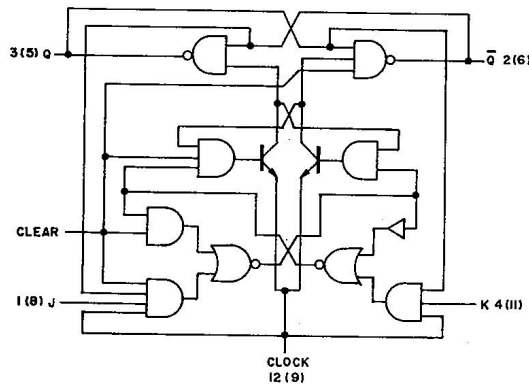
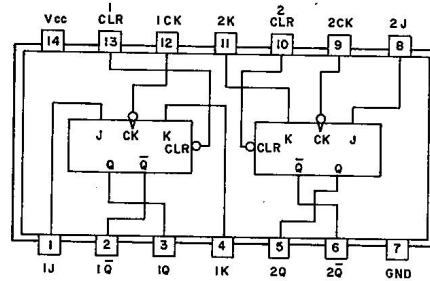

SN7402N

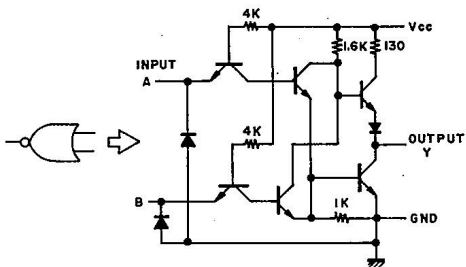
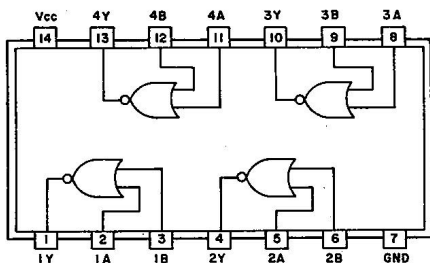

MSM4001RS

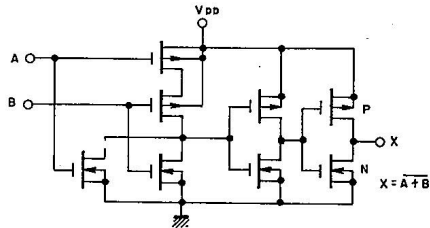
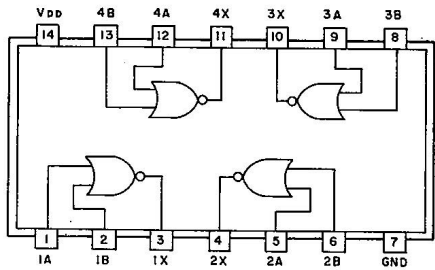

NJM4558D

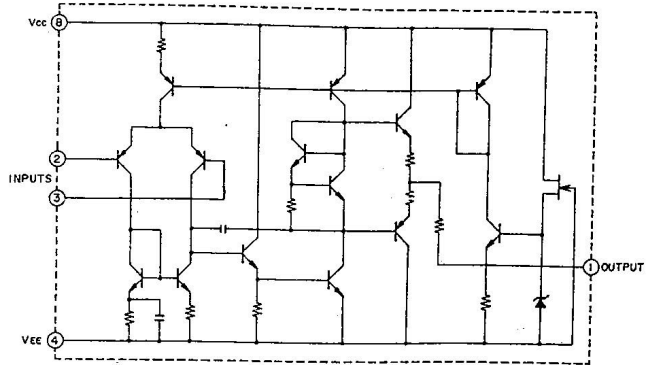
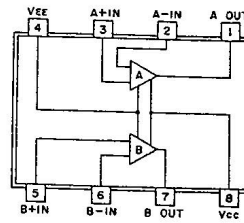

MSM4011RS

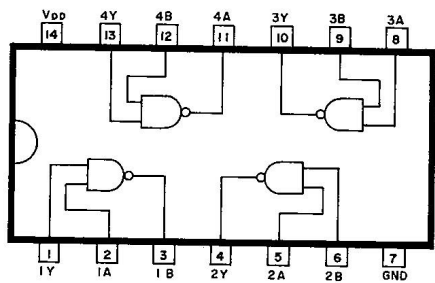

MSM4075RS

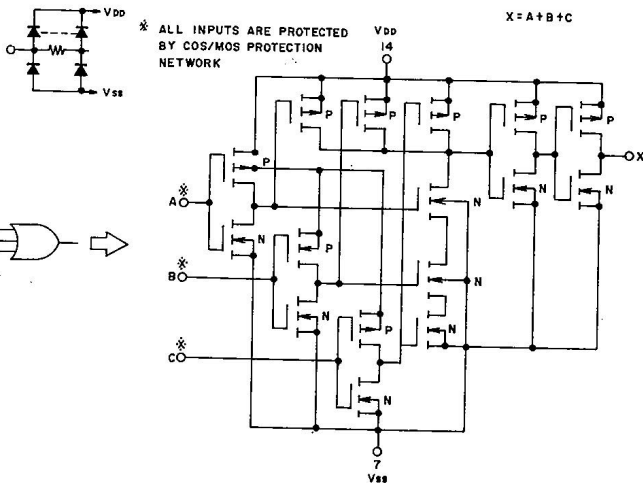
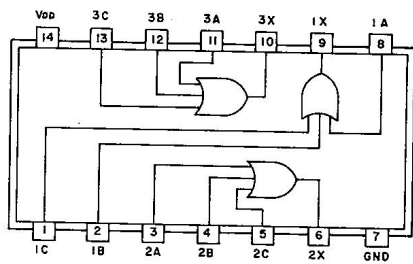

μPC629C

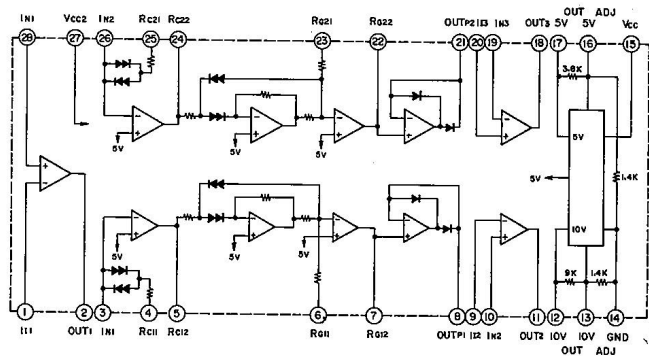

μPD4066C

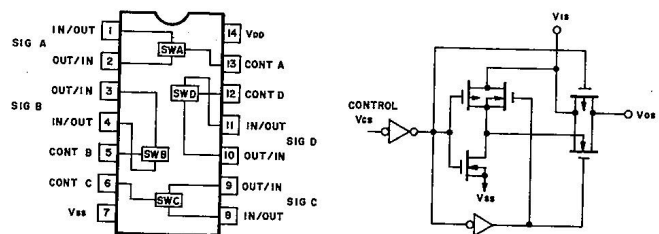

MSA-803RS

μ PC741C

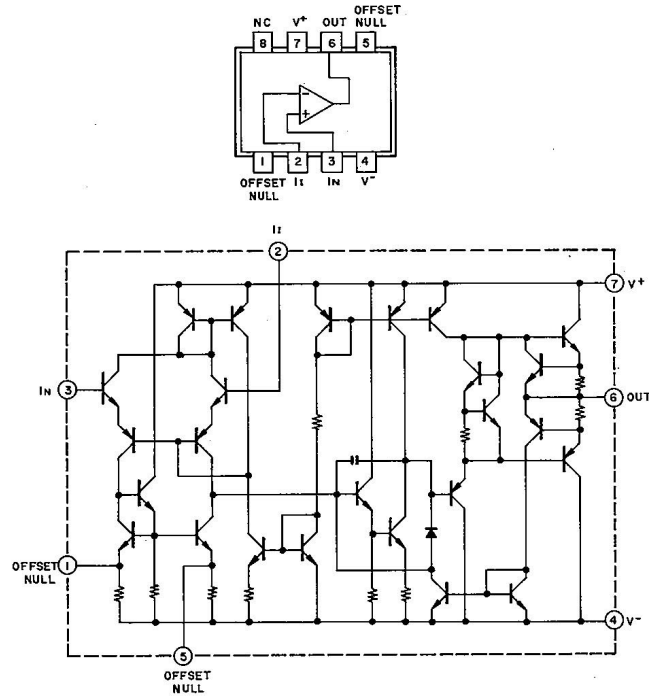
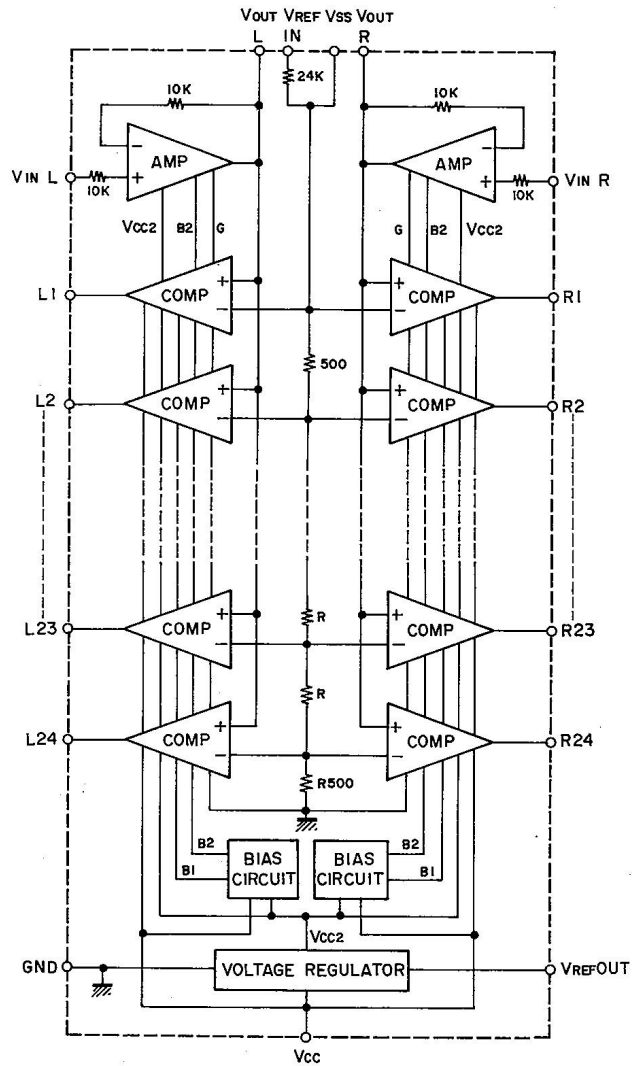

μ A7392PC

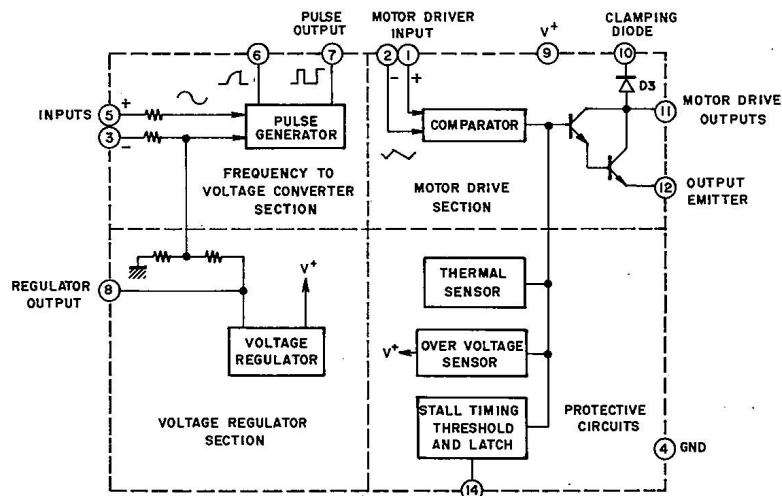

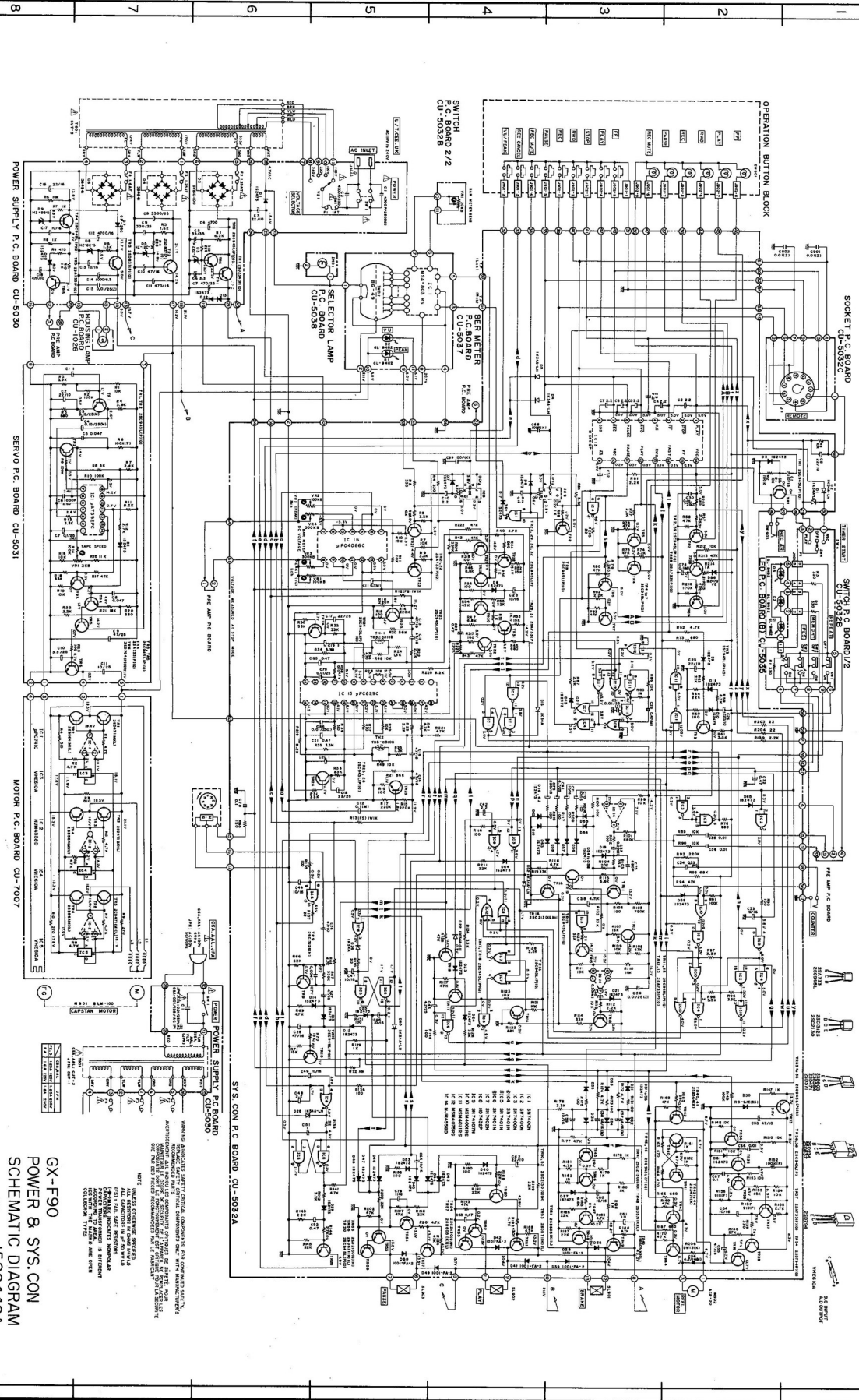

GX-F90
 POWER & SYS. CON
 SCHEMATIC DIAGRAM
 NO. 2-1 1582442A

NOTE: ALL DIMENSIONS ARE IN MILLIMETERS UNLESS OTHERWISE SPECIFIED.
 DIMENSIONS IN PARENTHESES ARE FOR REFERENCE ONLY.
 DIMENSIONS IN INCHES ARE FOR REFERENCE ONLY.
 DIMENSIONS IN MILLIMETERS ARE FOR REFERENCE ONLY.

AKAI ELECTRIC CO., LTD.

12-14, 2-Chome, Higashi-Kojiya, Ohta-Ku, Tokyo, Japan

TEL: Tokyo (742) 5111 CABLE: HIFIKAI TOKYO TELEX: J26261

Printed No. 1582414-471611 Printed Date: January 11, 1980

Printed in Japan