

SERVICE MANUAL

PARTS LIST

MODEL GXC-750D



ALSO APPLICABLE TO BLACK MODEL



AKAI STEREO CASSETTE DECK

MODEL **GXC-750D**

ALSO APPLICABLE TO BLACK MODEL

SECTION 1	SERVICE MANUAL	3
SECTION 2	PARTS LIST	35
SECTION 3	SCHEMATIC DIAGRAM	56

SECTION 1

SERVICE MANUAL

TABLE OF CONTENTS

I.	TECHNICAL DATA	4
II.	DISMANTLING OF UNIT	5
III.	CONTROLS	6
IV.	PRINCIPAL PARTS LOCATION	7
V.	SYSTEM CONTROL OPERATING PRINCIPLES	8
	1. TAPE SLACK ELIMINATION CIRCUIT	11
	2. PARKING BRAKE CIRCUIT	11
	3. PLAY PLUNGER OPERATING CIRCUIT	12
	4. OPERATION TIMING WHEN PLAY MODE IS EFFECTED FROM FAST FORWARD OR REWIND	12
	5. FAST FORWARD AND REWIND SPEED CONTROL CIRCUIT	13
	6. AUTOMATIC SHUT-OFF MECHANISM CIRCUIT	13
VI.	MECHANISM ADJUSTMENTS	14
	1. FLYWHEEL THRUST LOOSE PLAY ADJUSTMENT	14
	2. REEL TABLE INSTALLATION POSITION ADJUSTMENT	14
	3. PLAY PLUNGER INSTALLATION POSITION ADJUSTMENT	15
	4. PAUSE PLUNGER INSTALLATION POSITION ADJUSTMENT	15
	5. PINCH ROLLER PRESSURE ADJUSTMENT	16
	6. TAKE-UP TORQUE AT VARIOUS MODES AND TORQUE MEASURING METHOD	16
	7. LID PANEL POSITION ADJUSTMENT	16
	8. TAPE SPEED ADJUSTMENT	16
VII.	HEAD ADJUSTMENTS	18
	1. TAPE GUIDE HEIGHT ADJUSTMENT	18
	2. HEIGHT ADJUSTMENT OF RECORDING/PLAYBACK COMBINATION HEAD	18
	3. AZIMUTH ALIGNMENT ADJUSTMENT OF RECORDING/ PLAYBACK COMBINATION HEAD	18
VIII.	AMPLIFIER ADJUSTMENTS	19
IX.	DC RESISTANCE OF VARIOUS COILS	24
X.	CLASSIFICATION OF VARIOUS P.C BOARDS	24
	1. RELATION OF P.C BOARD TITLE AND IDENTIFICATION NUMBER	24
	2. COMPOSITION OF VARIOUS P.C BOARDS	25

For basic adjustments, measuring methods, and operating principles, refer to GENERAL OPERATING PRINCIPLES AND ADJUSTMENTS.

I. TECHNICAL DATA

TRACK SYSTEM	4 Track, 2 channel stereo system
TAPE	Philips type cassette tape
TAPE SPEED	1-7/8 ips
WOW & FLUTTER	Less than 0.06% WRMS. 0.17% (DIN 45500)
FREQUENCY RESPONSE	35 to 15,000 Hz ± 3 dB at LN position 35 to 15,000 Hz ± 3 dB at LH position 35 to 16,000 Hz ± 3 dB at CrO ₂ position 35 to 18,000 Hz ± 3 dB at FeCr position
DISTORTION	Less than 1.0% at LN position Less than 1.0% at LH position Less than 1.5% at CrO ₂ position Less than 1.5% at FeCr position
SIGNAL TO NOISE RATIO	Better than 56 dB at CrO ₂ position (DIN 45500) Dolby NR switch ON: Improves up to 10 dB above 5 kHz
ERASE RATIO	Better than 70 dB
BIAS FREQUENCY	100 kHz
HEADS	3 head system (one GX recording/playback head and one erase head)
MOTORS	3 motor system (one DC FG servo motor for capstan drive and two DC motors for reel drive)
F.F. & REWIND TIME	60 sec. using a C-60 Tape
OUTPUT JACKS	Line (2): 410 mV (0 VU) Required load impedance: more than 47 kohms Phone (1): 100 mV/8 ohms
INPUT JACKS	Microphone (2): 0.25 mV (input impedance 2.4 kohms) Required microphone impedance: 600 ohms Line (2): 70 mV (input impedance 100 kohms)
SEMICONDUCTORS	Transistors: 75, Diodes: 124, FETs: 4, ICs: 18
POWER REQUIREMENTS	120V/60 Hz for U.S.A. & Canada 240V/50 Hz for Australia, 100V, 50/60 Hz for Japan 110-120V/220-240V, 50/60 Hz for other countries
DIMENSIONS	440(W) \times 318 \times 157(D) mm (17.3 \times 12.5 \times 6.2) inches
WEIGHT	9.5 kg (21.0 lbs)

NOTE: Standard reference tapes

LN position: AKAI C-60LN, FUJI FL C-60
LH position: MAXELL UD C-60
CrO₂ position: TDK SA C-60
FeCr position: SONY Duad C-60

* For improvement purposes, specifications and design are subject to change without notice.

* "Dolby" and the Double D symbol are trademarks of Dolby Laboratories. (Manufactured under license from Dolby Laboratories.)

II. DISMANTLING OF UNIT

In case of trouble, etc. necessitating disassembly, please disassemble in the order shown in photographs. Reassemble in reverse order.

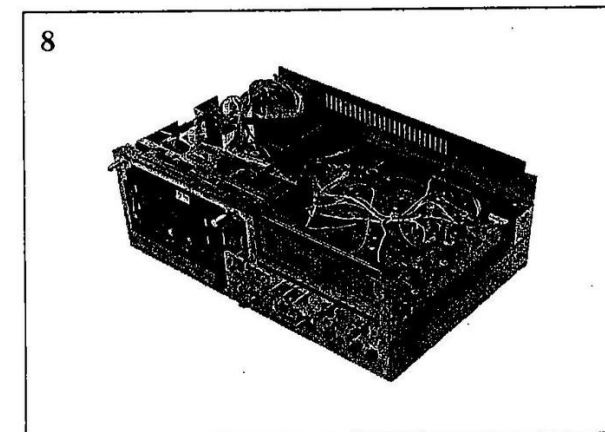
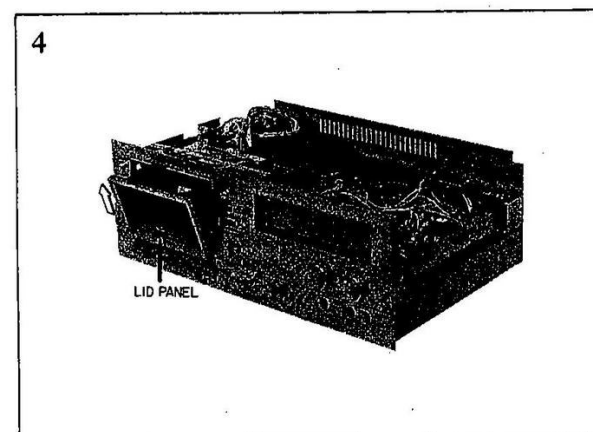
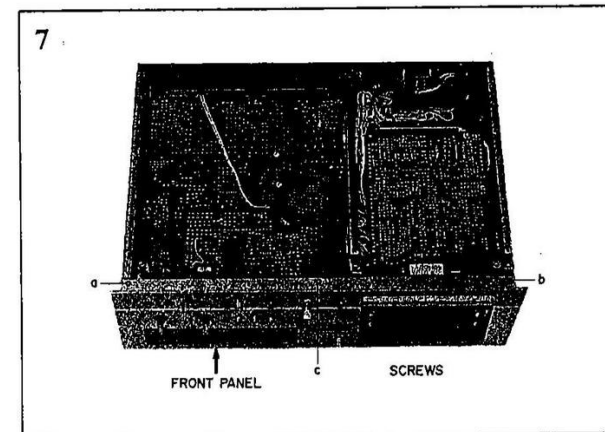
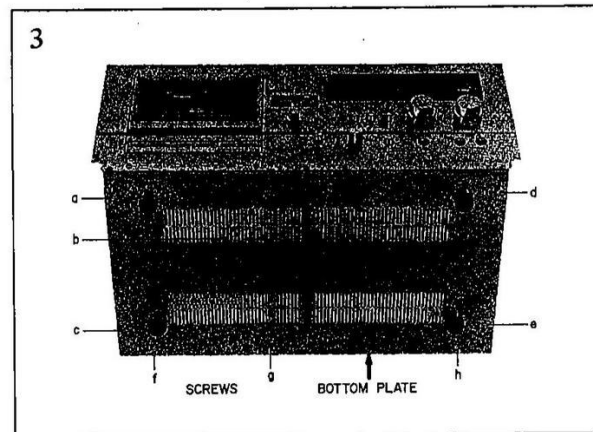
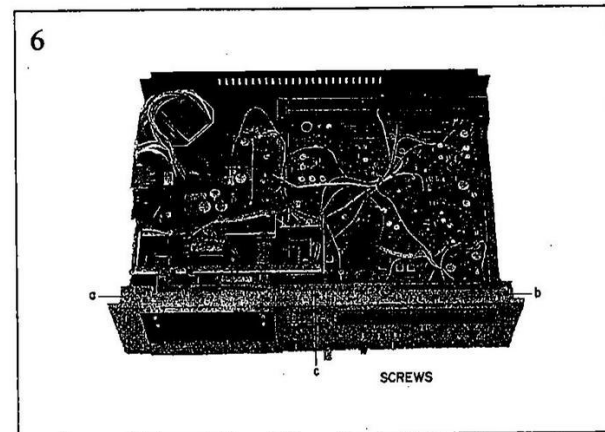
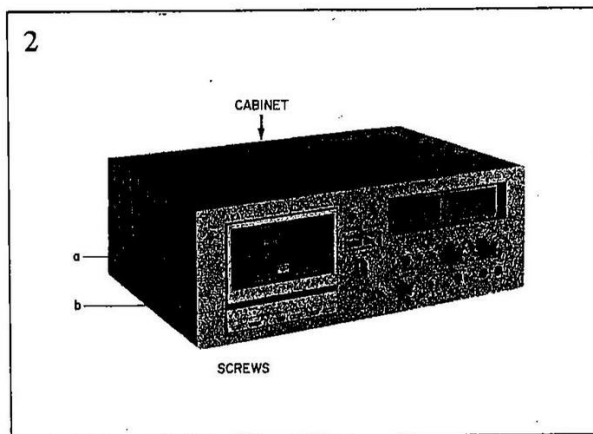
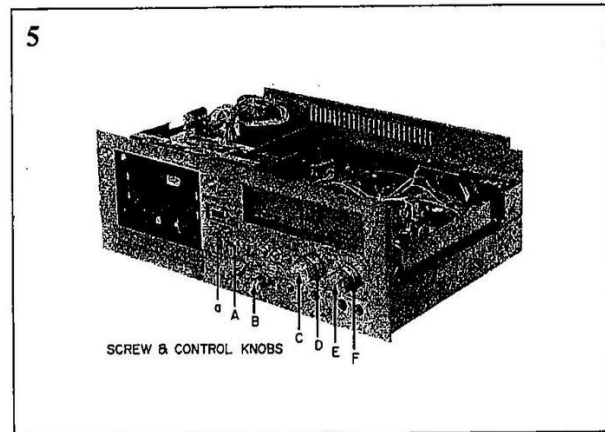
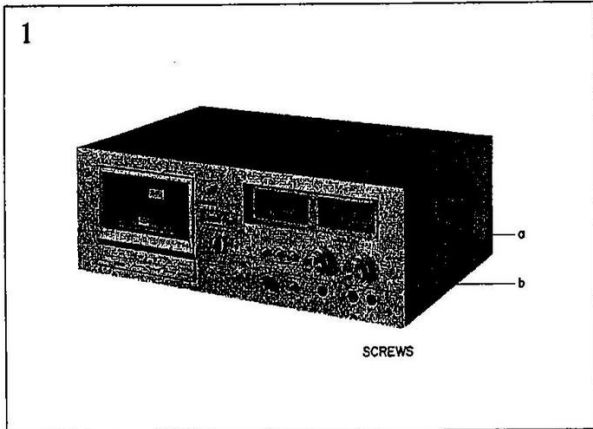

III. CONTROLS

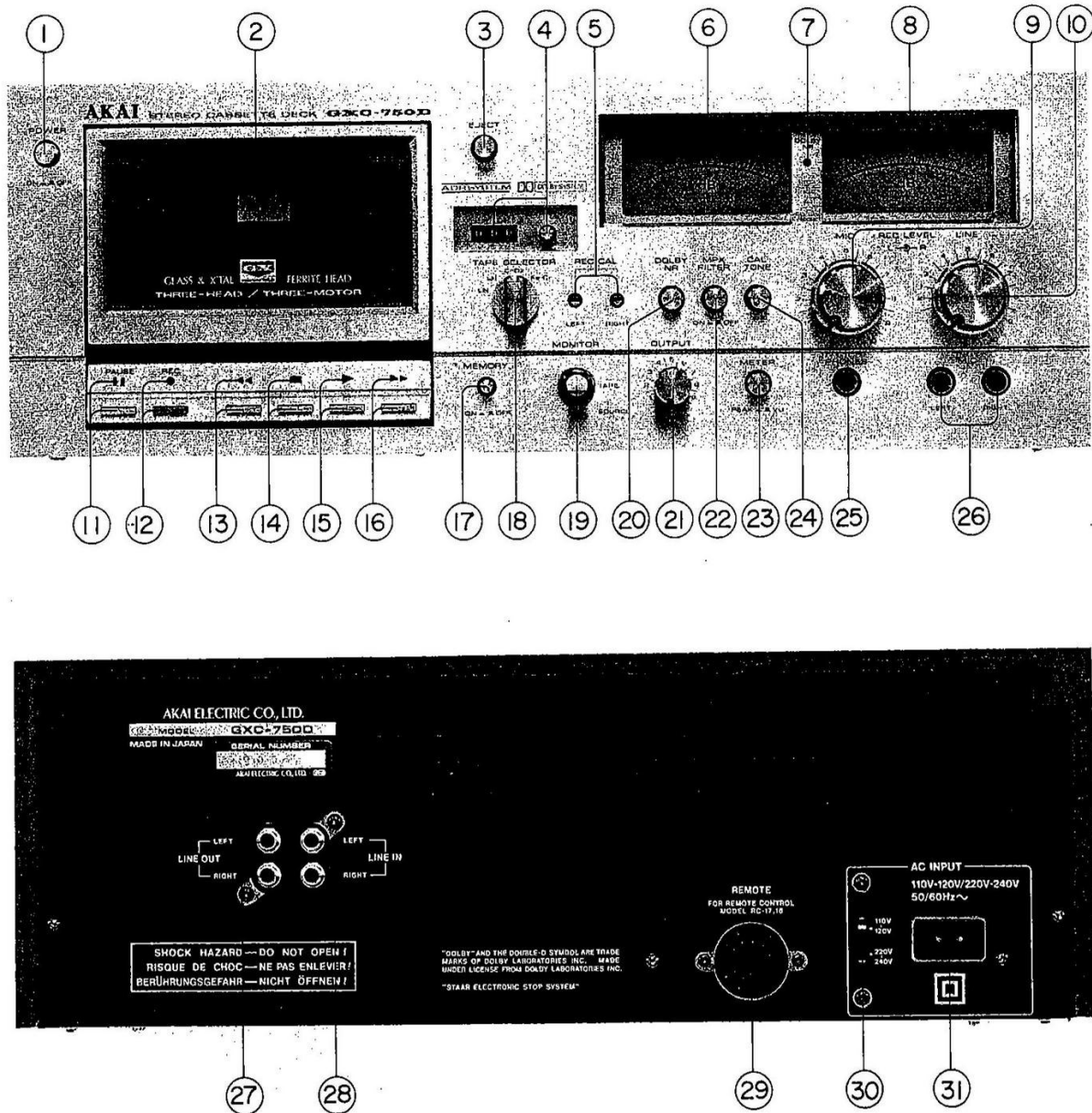

Fig. 1 Controls

- | | |
|--|--|
| 1. POWER SWITCH | 16. FAST FORWARD BUTTON AND INDICATOR LAMP |
| 2. CASSETTE RECEPTACLE | 17. MEMORY REWIND BUTTON |
| 3. EJECT BUTTON | 18. TAPE SELECTOR |
| 4. INDEX COUNTER AND RESET BUTTON | 19. TAPE MONITOR SWITCH |
| 5. REC CAL ADJUSTERS (left and right) | 20. DOLBY N.R. SWITCH |
| 6. LEFT VU/PEAK LEVEL METER | 21. OUTPUT LEVEL CONTROL |
| 7. DOLBY INDICATOR LAMP | 22. MPX FILTER SWITCH |
| 8. RIGHT VU/PEAK LEVEL METER | 23. METER SWITCH |
| 9. MICROPHONE RECORDING LEVEL CONTROLS | 24. CAL TONE SWITCH |
| (left and right) | 25. HEADPHONE JACK |
| 10. LINE RECORDING LEVEL CONTROLS (left and right) | 26. MICROPHONE JACKS (left and right) |
| 11. PAUSE BUTTON AND INDICATOR LAMP | 27. LINE OUTPUT JACKS (left and right) |
| 12. RECORDING BUTTON AND INDICATOR LAMP | 28. LINE INPUT JACKS (left and right) |
| 13. REWIND BUTTON AND INDICATOR LAMP | 29. REMOTE CONTROL JACK |
| 14. STOP BUTTON | 30. VOLTAGE SELECTOR SWITCH |
| 15. PLAY BUTTON AND INDICATOR LAMP | 31. AC INLET |

IV. PRINCIPAL PARTS LOCATION

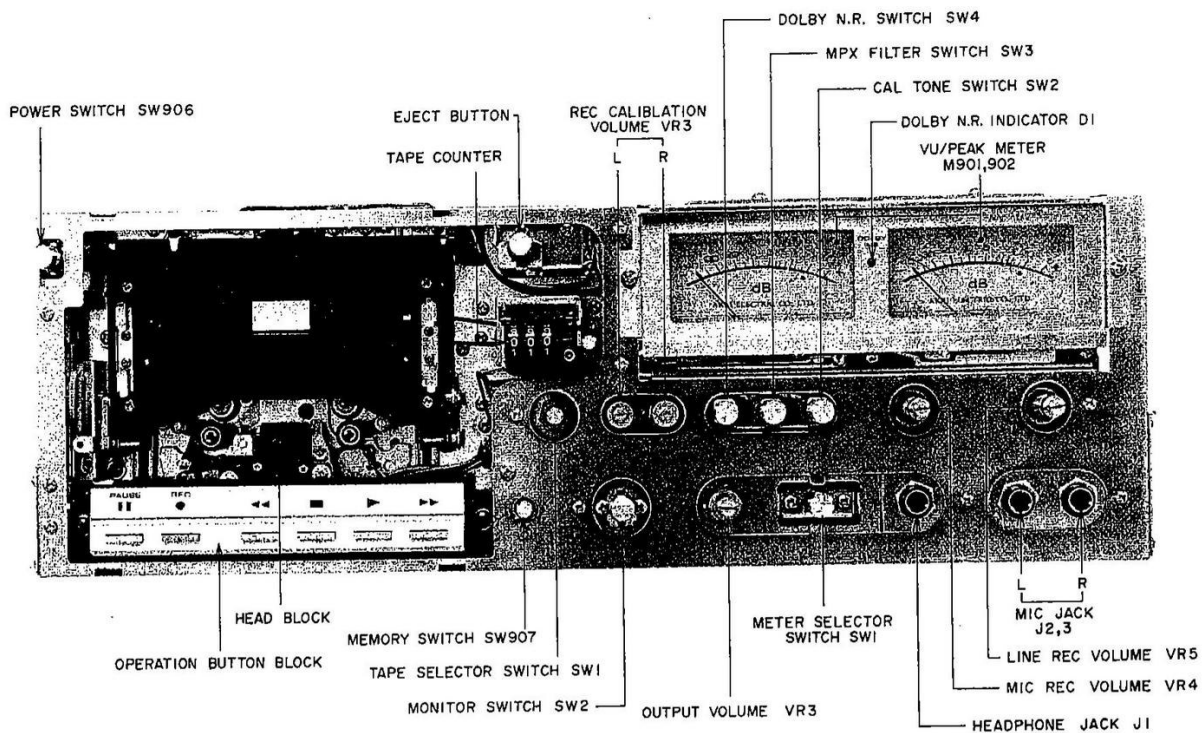

Fig. 2 Front View

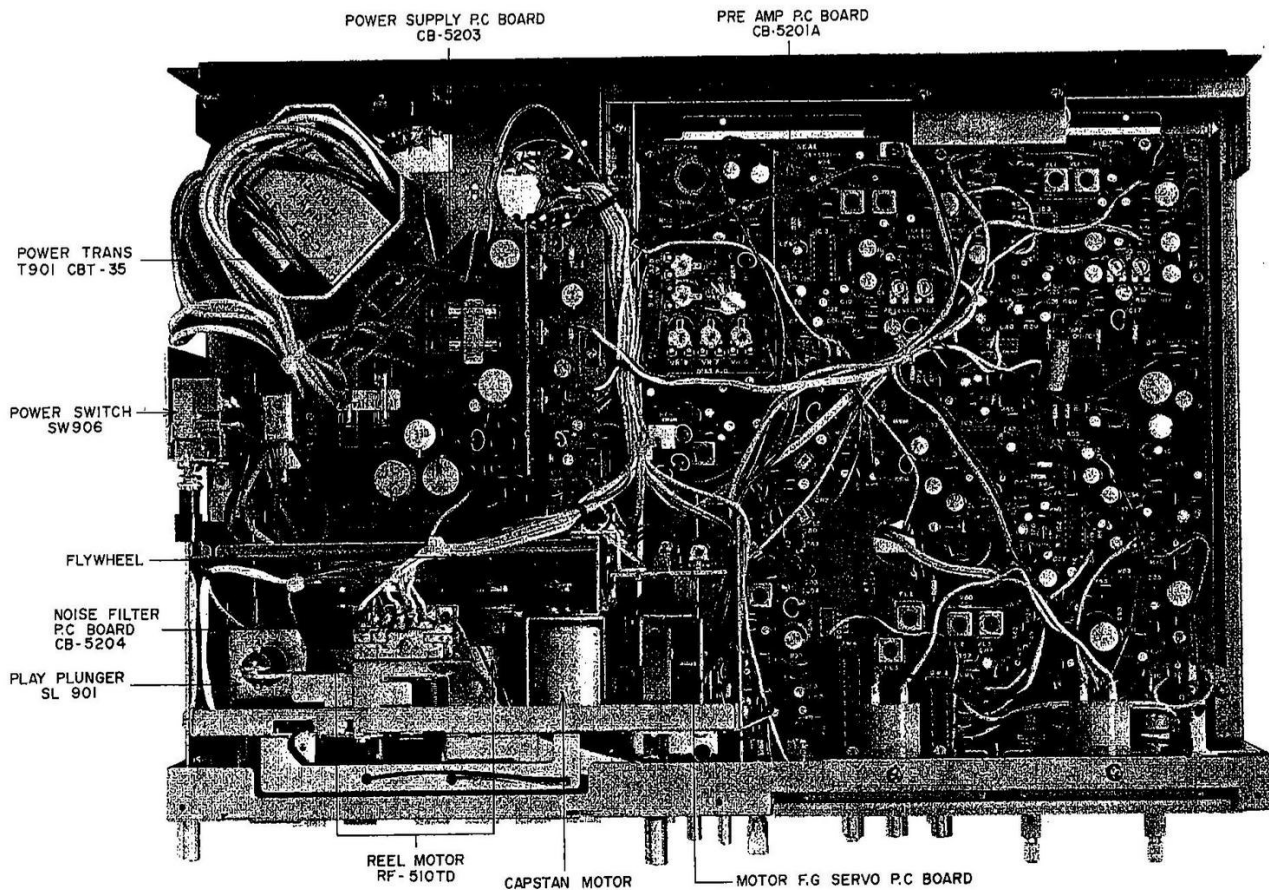
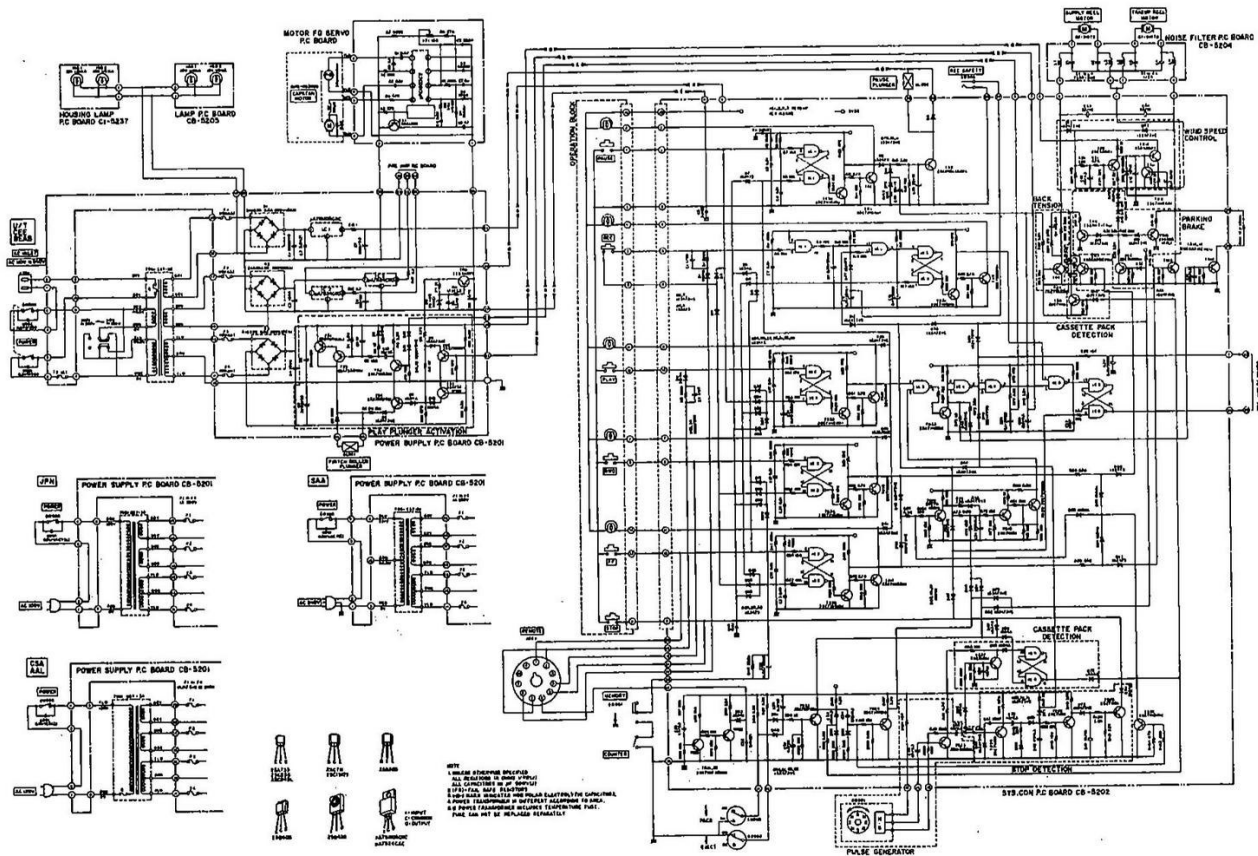

Fig. 3 Top View

V. SYSTEM CONTROL OPERATING PRINCIPLES

	SYMBOL	TRUTH TABLE															
NAND CIRCUIT		<table border="1"> <thead> <tr> <th>A</th> <th>B</th> <th>X</th> </tr> </thead> <tbody> <tr> <td>0</td> <td>0</td> <td>1</td> </tr> <tr> <td>1</td> <td>0</td> <td>1</td> </tr> <tr> <td>0</td> <td>1</td> <td>1</td> </tr> <tr> <td>1</td> <td>1</td> <td>0</td> </tr> </tbody> </table>	A	B	X	0	0	1	1	0	1	0	1	1	1	1	0
		A	B	X													
0	0	1															
1	0	1															
0	1	1															
1	1	0															
	$X = \overline{A \cdot B}$																

Chart-1



Schematic-1

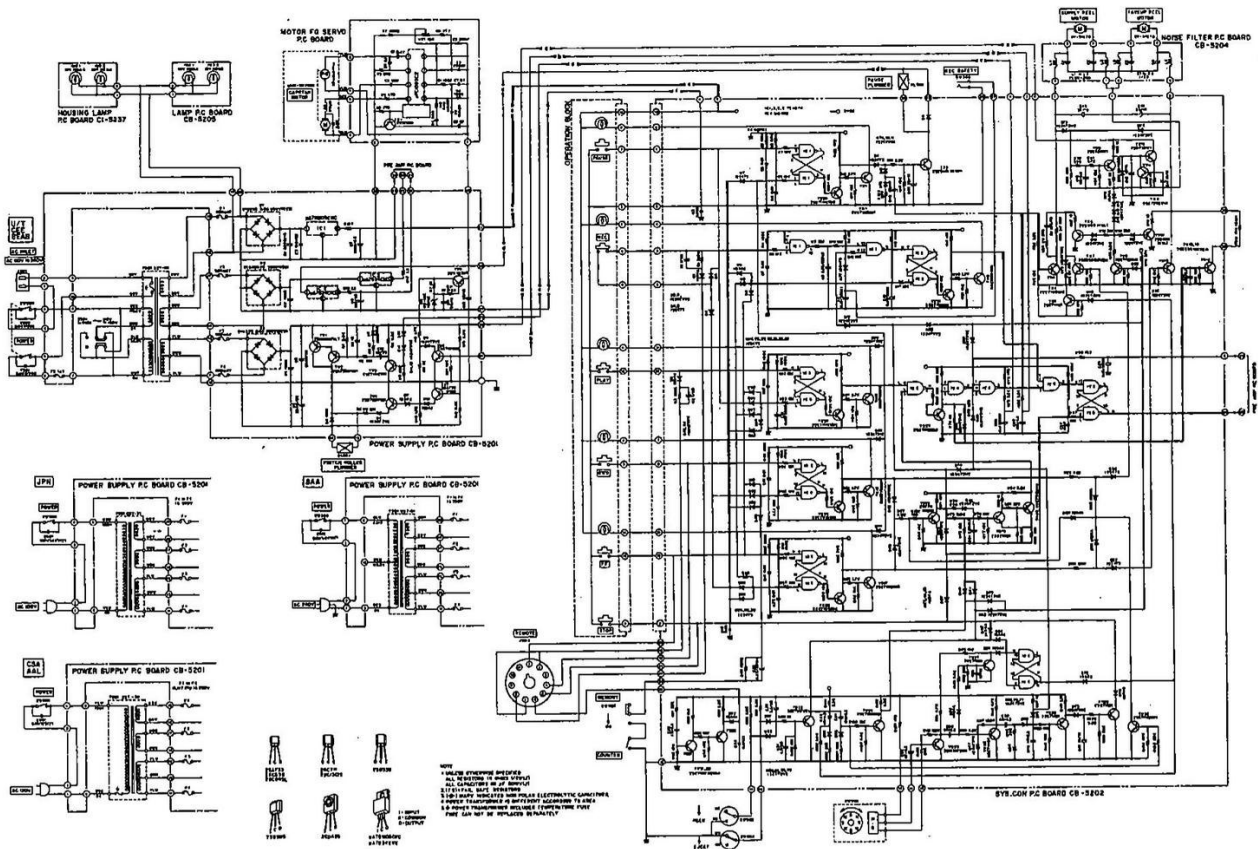

Schematic-2 STOP MODE

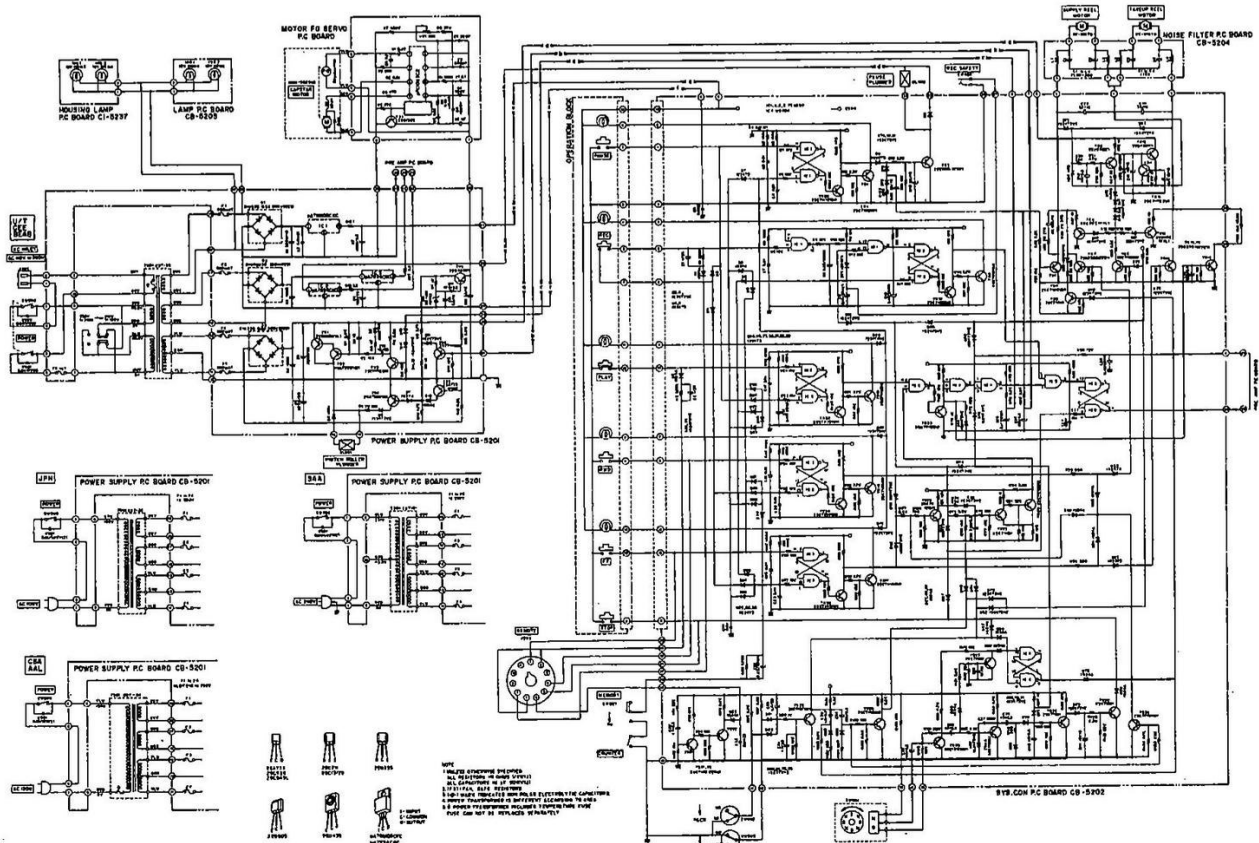

Schematic-3 PLAY MODE

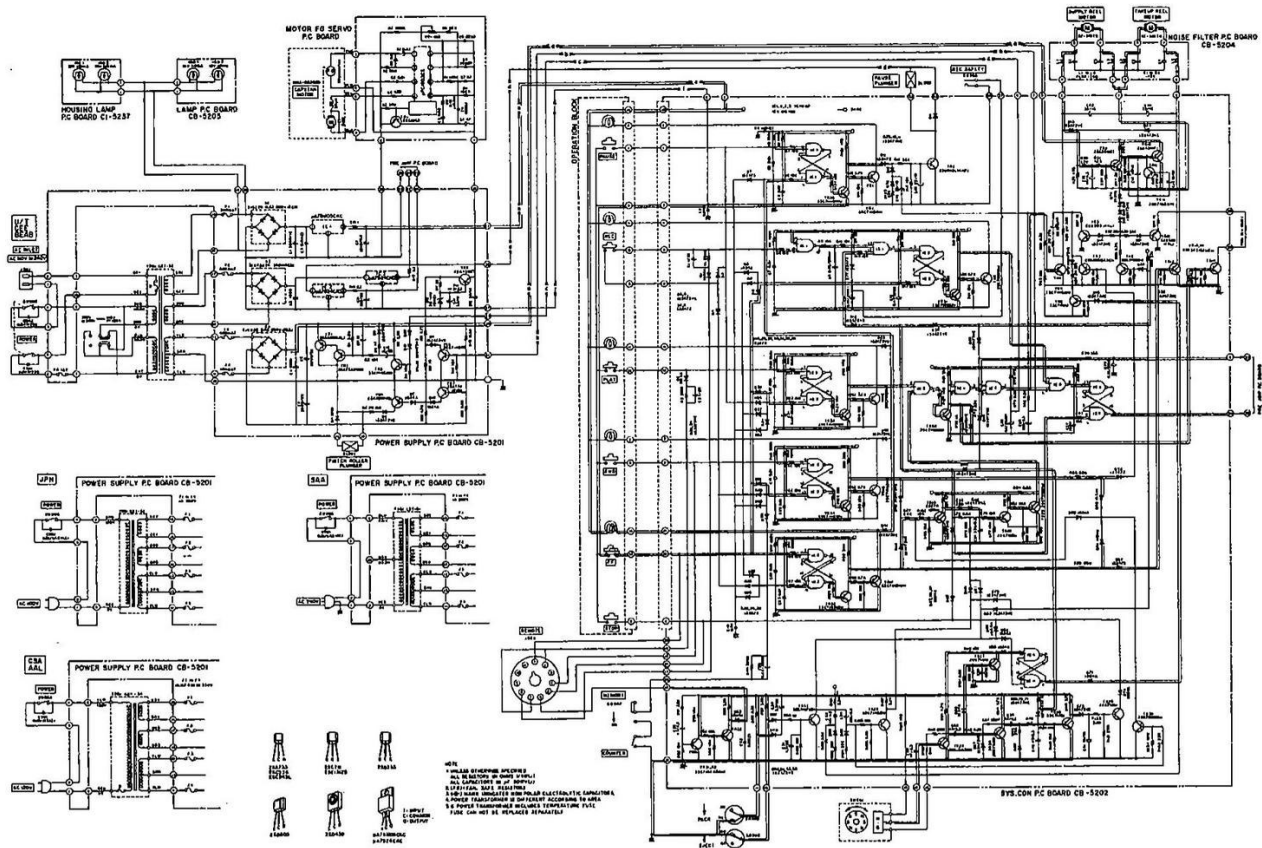

Schematic-4 FF MODE

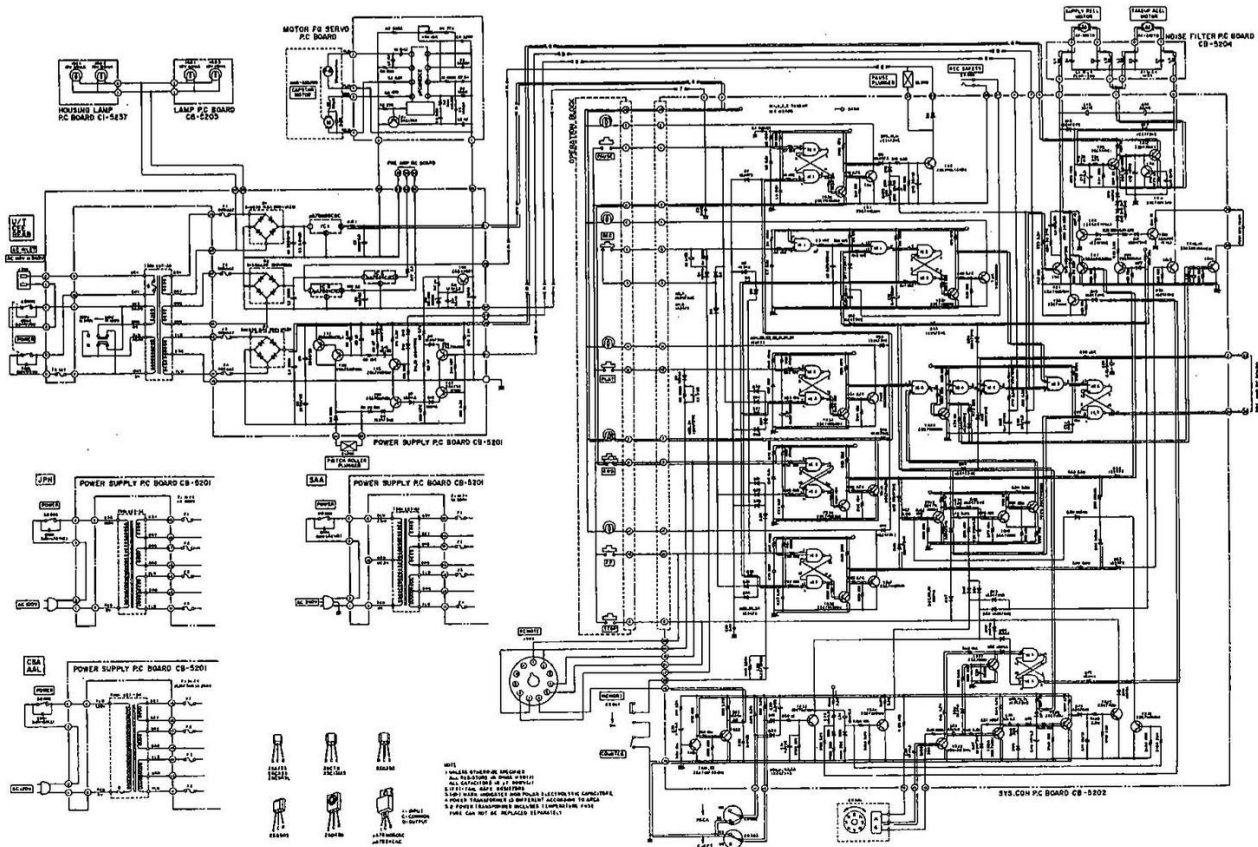

Schematic-5 RWD MODE

1. TAPE SLACK ELIMINATION CIRCUIT

- 1) This deck employs a double capstan drive system. Consequently, when a play mode is effected with a great deal of slack, tape may triangle into the mechanism to cause trouble. Or even when there is only a slight slack, it takes a long period of time to obtain the optimum loop tension and correct bad head-to-tape contact.

The purpose of this circuit is to take-up the tape slack beforehand to obtain correct tape tension for smooth operation and to prevent the undesirable conditions.

- 2) When the cassette is not loaded, the cassette pack detection circuit micro switch SW902 is OPEN. Therefore, base electric current flows as $R96 \rightarrow D60 \rightarrow R98 \rightarrow TR23$ and TR23 is ON.

Also, when the Eject is effected, SW902 closes. But in this case, Eject Switch SW903 is OPEN to cause base electric current to flow $R97 \rightarrow D61 \rightarrow D98 \rightarrow TR23$ and maintain TR23 ON condition. When the cassette is loaded, Eject Switch SW903 closes, and since SW902 is also closed, electric current is not supplied to TR23 base and TR23 is OFF. When TR23 is turned OFF, C33 charging current flows as $R101 \rightarrow C33 \rightarrow R103 \rightarrow D16 \rightarrow TR5$. Also, because the Take-up Reel Motor and the interlocked rotary magnet are not rotating at this time, IC4 output terminal ⑧ is at a high level. While C33 is being charged, TR5 base electric potential increases to turn TR5 ON. When TR5 is turned ON, electric current flows to the Supply Reel Motor through D78, R26 and rotates it to remove the tape slack.

- 3) After C33 is completely charged by the electric current $R101 \rightarrow C33 \rightarrow R103 \rightarrow D16 \rightarrow TR5$, TR5 is turned OFF. Or else, even when C33 is still being charged, Take-up Reel Motor may start to rotate when Supply Reel Motor rotates and completes to Pull-up tape slack. When Take-up Reel Motor rotates, interlocked SW901 rotary magnet begins to rotate. The resulting pulse electric current flows a $C35 \rightarrow TR25 \rightarrow C36 \rightarrow D66 \rightarrow R131 \rightarrow C38$ and charges C38 to increase TR27 base electric potential and turn TR27 ON. When TR27 is turned ON, IC4 input terminal ⑬ becomes ground electric potential through D69 and TR27 and therefore, output terminal ⑧ becomes low level by the inversion of the flip flop output.

For this reason, C33 charging current stops flowing to TR5 base and turns TR5 OFF. When TR5 is turned OFF in either case, electric current is not supplied to Supply Reel Motor and the rotation stops.

2. PARKING BRAKE CIRCUIT

- 1) To prevent tape slack from forming at Stop mode, tape is pulled slightly in both directions by this circuit. Electric current are supplied to the two reel motors for slight torques.
- 2) When the tape is not loaded, TR23 is ON and D22 anode, through D52 connected to the collector, is ground potential. TR8 is therefore OFF. When the tape is loaded, TR23 is turned OFF. The charging current of C34 flows ($R101 \rightarrow C34 \rightarrow R105 \rightarrow TR24$) and TR24 base electric potential increases to turn ON. Through collector connected D79, D22 anode becomes ground potential. Consequently, TR8 maintains OFF condition. During this time tape slack is taken up.
- 3) After C34 is charged, TR24 is turned OFF and bias is supplied to TR8 base through R40 and D22 from 5V Line. TR8 is thereby turned ON and causes D19 cathode electric potential to decrease. TR6 base electric potential is then decreased through R32 and D14. At the same time, TR10 base electric potential is decreased through R38 and D21 so that TR6 and TR10 are turned ON. As a result, the Supply Reel Motor and the Take-up Reel Motor rotate from the electric current supplied through R27, TR6 and R21, TR10 respectively. Since the torques are toward pulling the tape at both ends, tape is at a standstill.
- 4) At Play mode, IC4 output terminal ⑥ is at a low level so that D22 anode electric potential decreases through D58, and TR8 is turned OFF. At Fast Forward and Rewind mode, TR18 is turned ON. D22 anode becomes ground potential through D55, and TR8 turned OFF. Thus, tape slack is prevented at Stop mode by a parking brake from the weak torques.

3. PLAY PLUNGER OPERATING CIRCUIT

- 1) This circuit starts Play Plunger operation by supplying a large amount of electric current and then maintains the operations, once it's started, by a small electric current. This deck is transistor driven and does not employ relays. It operates on a plus-minus power supply.
- 2) When the deck is set to PLAY mode, IC4 output terminal ③ of the system control circuit reaches a high level and C26 is charged through R79, C25 and R82. But since the charging time of C25 is shorter, its terminal voltage is increased faster than that of C26 and is added to TR3 base through power supply circuit D12 and D11. TR3 turns ON, and C10 charging current flows as R1 → R2 → C10 → TR3. While C10 is charged, TR2 base electric potential decreases to turn TR2 ON and the Darlington-connected TR1 base electric potential also decreases to turn TR1 ON. Thus the Play Plunger is supplied with voltage of ⊕ electric potential and ⊖ electric potential and starts operation.
Now, when charging of C26 is completed, C26 terminal voltage is added to TR6 base of the power supply circuit. TR6 is thereby turned ON and D9 anode terminal becomes ground electric potential. When that happens, D7 cathode terminal becomes lower than the ground electric potential and turns TR4 ON. For this reason, even when TR2 and TR1 is turned OFF after charging of C10 is completed, electric current flows to the Play Plunger from ⊖ power supply through ground → TR4 → D6 → R4 to maintain operation.
- 3) Because the Play Plunger Operating Circuit is on a plus-minus power supply of C5 and C6, when the power switch is turned OFF during PLAY mode, condenser C5 discharges faster than C6 due to the fact that the load of C5 on the ⊕ side is larger than C6.

This causes the pinch roller to stay in contact with the capstan for a little while after the reel motor have stopped, and results in loose tape coming out of the cassette pack due to the flywheel inertia. In order to prevent the malfunction, Play Plunger is disengaged, simultaneously, when the reel motors are stopped by the discharge of C5.

When the power switch is turned OFF at PLAY mode, C5 discharges faster than C6 and the reel motors stop. At the same time, since the condition between TR7 base and R13 can be thought of as OPEN, the C6 leftover ⊖ electric potential is added to TR7 base and TR7 is turned ON. Therefore, D7 cathode becomes ground potential, TR4 is turned OFF, and the electric current stops flowing to the Play Plunger to disengage it.

4. OPERATION TIMING WHEN PLAY MODE IS EFFECTED FROM FAST FORWARD OR REWIND

- 1) When the PLAY mode is effected from Fast Forward or Rewind, if the Play Plunger functions to operate the pinch roller before tape travel has ceased, a brake will be instantly applied in such a way as to cut or stretch the tape.
To eliminate the problem, this circuit allows the reel motors to stop completely before the pinch roller operation takes place when the PLAY mode is effected from Fast Forward or Rewind.
- 2) During Fast Forward or Rewind TR18 is ON and C24 is discharged through D46 → R74 → TR18. At the same time, TR19 is OFF and TR20 is ON. Consequently, TR20 collector connected IC5 input terminal ⑤ is low level. When the PLAY mode is effected from Fast Forward or Rewind, TR18 is turned OFF and C24 is charged through R71 and R73. During the charging time, TR19 base electric potential is low that it is in OFF condition and TR20 is ON. On the other hand, IC5 input terminal ⑥ becomes high level but because the input terminal ⑤ is low level due to TR20 ON, high level shows up at output terminal ④. PLAY mode is therefore not effected.
When C24 is charged and TR19 base electric potential is increased to turn TR19 ON, TR20 base electric potential is decreased to turn TR20 OFF. Also, it results in a high level IC5 input terminals ⑤ and ⑥. Therefore output terminals ④ becomes low level to put PLAY mode into effect. In this manner, when the PLAY mode is effected from Fast Forward or Rewind, Play Plunger does not function while C24 is being charged.

5. FAST FORWARD AND REWIND SPEED CONTROL CIRCUIT

- 1) The reel motors of this deck are DC motors which at a non-load condition rotate at a high speed. Consequently, when Fast Forward or Rewind is effected, there is a possibility of tape damage due to gradual build-up of inertia and increased revolutions. The purpose of this circuit is to control the voltage supply to the take-up reel in order to prevent increased motor revolutions.
- 2) When the deck is set to Fast Forward mode, TR13 is turned ON and the take-up motor begins to rotate. When the supply reel motor is not rotating, because bias is not supplied to the base of TR9, the resistance between TR3 collector and emitter is infinite, and a fixed bias is supplied to TR12 through R35 and C13, a fixed DC voltage is supplied to the take-up reel motor, and there is a gradual build-up of inertia and gradual increase in the motor revolutions. However, at Fast Forward mode, the supply reel motor functions as a generator. Consequently, the electromotive force generated by the supply reel motor passes D13, R30 and R31 and becomes TR9 base bias, and the resistance between TR9 collector and emitter varies proportionately according to the extent of the generator's electromotive force. That is to say, the variation in the resistance between TR3 collector and emitter influences the bias supplied to the TR12 base.
For example, let's say that the take-up reel begins to rotate at a very high speed. This causes a counterbalanced electromotive force to be generated by the supply reel motor and this generated voltage decreases the resistance between TR9 collector and emitter and lowers the TR12 bias. Then the resistance between TR12 collector and emitter is increased, the supply voltage to the take-up reel is decreased, and finally the motor revolution is decreased. Thus, the take-up speed always corresponds with the supply reel motor speed to prevent high speed motor revolutions.
- 3) In case by some irregularity, the collector current of TR12 is increased to cause high speed rotation, R43 terminal voltage is increased, bias is supplied to TR11 base, the resistance between TR11 collector and emitter is decreased, TR12 bias is lowered, and the collector current is decreased.
- 4) Speed control also functions in exactly the same way at Rewind mode. However, in this case, the right hand side reel motor functions as a generator, and left hand side reel motor revolutions are controlled by means of supply voltage control. Therefore, rewind speed is controlled in the same way as at fast forward.

6. AUTOMATIC SHUT-OFF MECHANISM CIRCUIT

- 1) This circuit is for the purpose of effecting automatic shut-off when tape travel has stopped after play, recording, fast forward, or rewind mode.
- 2) During tape travel TR25 performs an ON ↔ OFF switching operation because of the pulse generating from a rotating rotary magnet within SW9. Also during tape travel, charge and discharge current alternately flows to C36 due to the TR25 switching operation that TR26 also performs an ON ↔ OFF switching operation. From the TR26 switching operation, charge and discharge current alternately flows to C39. Only when C39 is charged, TR28 base electric potential increases and TR28 is turned ON. This is because C40 is charged through D70. On the other hand, when C39 is discharged, C40 discharge current flows through R130 → R118 → ground and TR28 base electric potential gradually decreases. But before TR28 is turned OFF, C40 is charged by the charging current from C39 that TR28 ON condition is maintained. Consequently, TR29 is in OFF condition because TR29 base is ground potential.
- 3) When tape travel stops, C39 charge and discharge current stops, C40 discharge ends, and TR28 turns OFF. Then, the TR29 base electric potential increases to turn TR29 ON, and through D74 which is connected to TR29 collector, ⊕ side of the STOP switch is grounded to effect STOP mode.
- 4) Also, this circuit functions only when PLAY, FAST FORWARD, or REWIND circuit is in operation. When these are not in operation, direct current voltage is supplied to C40 through R117 and D71, TR28 is turned ON, and TR29 OFF condition is maintained.
When PLAY mode is in operation, low level IC4 output terminal ⑥ causes D71 anode electric potential to be decreased to near ground potential through D48. And when FAST FORWARD OR REWIND is in operation, because TR18 is ON, D71 anode electric potential is decreased to near ground potential through D44 and TR18. Consequently, TR29 is turned ON by pulse electric current from SW901 only when PLAY, FAST FORWARD, REWIND circuit is in operation.

5. FAST FORWARD AND REWIND SPEED CONTROL CIRCUIT

- 1) The reel motors of this deck are DC motors which at a non-load condition rotate at a high speed. Consequently, when Fast Forward or Rewind is effected, there is a possibility of tape damage due to gradual build-up of inertia and increased revolutions. The purpose of this circuit is to control the voltage supply to the take-up reel in order to prevent increased motor revolutions.
- 2) When the deck is set to Fast Forward mode, TR13 is turned ON and the take-up motor begins to rotate. When the supply reel motor is not rotating, because bias is not supplied to the base of TR9, the resistance between TR3 collector and emitter is infinite, and a fixed bias is supplied to TR12 through R35 and C13, a fixed DC voltage is supplied to the take-up reel motor, and there is a gradual build-up of inertia and gradual increase in the motor revolutions. However, at Fast Forward mode, the supply reel motor functions as a generator. Consequently, the electromotive force generated by the supply reel motor passes D13, R30 and R31 and becomes TR9 base bias, and the resistance between TR9 collector and emitter varies proportionately according to the extent of the generator's electromotive force. That is to say, the variation in the resistance between TR3 collector and emitter influences the bias supplied to the TR12 base.
For example, let's say that the take-up reel begins to rotate at a very high speed. This causes a counterbalanced electromotive force to be generated by the supply reel motor and this generated voltage decreases the resistance between TR9 collector and emitter and lowers the TR12 bias. Then the resistance between TR12 collector and emitter is increased, the supply voltage to the take-up reel is decreased, and finally the motor revolution is decreased. Thus, the take-up speed always corresponds with the supply reel motor speed to prevent high speed motor revolutions.
- 3) In case by some irregularity, the collector current of TR12 is increased to cause high speed rotation, R43 terminal voltage is increased, bias is supplied to TR11 base, the resistance between TR11 collector and emitter is decreased, TR12 bias is lowered, and the collector current is decreased.
- 4) Speed control also functions in exactly the same way at Rewind mode. However, in this case, the right hand side reel motor functions as a generator, and left hand side reel motor revolutions are controlled by means of supply voltage control. Therefore, rewind speed is controlled in the same way as at fast forward.

6. AUTOMATIC SHUT-OFF MECHANISM CIRCUIT

- 1) This circuit is for the purpose of effecting automatic shut-off when tape travel has stopped after play, recording, fast forward, or rewind mode.
- 2) During tape travel TR25 performs an ON ↔ OFF switching operation because of the pulse generating from a rotating rotary magnet within SW9. Also during tape travel, charge and discharge current alternately flows to C36 due to the TR25 switching operation that TR26 also performs an ON ↔ OFF switching operation. From the TR26 switching operation, charge and discharge current alternately flows to C39. Only when C39 is charged, TR28 base electric potential increases and TR28 is turned ON. This is because C40 is charged through D70. On the other hand, when C39 is discharged, C40 discharge current flows through R130 → R118 → ground and TR28 base electric potential gradually decreases. But before TR28 is turned OFF, C40 is charged by the charging current from C39 that TR28 ON condition is maintained. Consequently, TR29 is in OFF condition because TR29 base is ground potential.
- 3) When tape travel stops, C39 charge and discharge current stops, C40 discharge ends, and TR28 turns OFF. Then, the TR29 base electric potential increases to turn TR29 ON, and through D74 which is connected to TR29 collector, ⊕ side of the STOP switch is grounded to effect STOP mode.
- 4) Also, this circuit functions only when PLAY, FAST FORWARD, or REWIND circuit is in operation. When these are not in operation, direct current voltage is supplied to C40 through R117 and D71, TR28 is turned ON, and TR29 OFF condition is maintained.
When PLAY mode is in operation, low level IC4 output terminal ⑥ causes D71 anode electric potential to be decreased to near ground potential through D48. And when FAST FORWARD OR REWIND is in operation, because TR18 is ON, D71 anode electric potential is decreased to near ground potential through D44 and TR18. Consequently, TR29 is turned ON by pulse electric current from SW901 only when PLAY, FAST FORWARD, REWIND circuit is in operation.

VI. MECHANISM ADJUSTMENTS

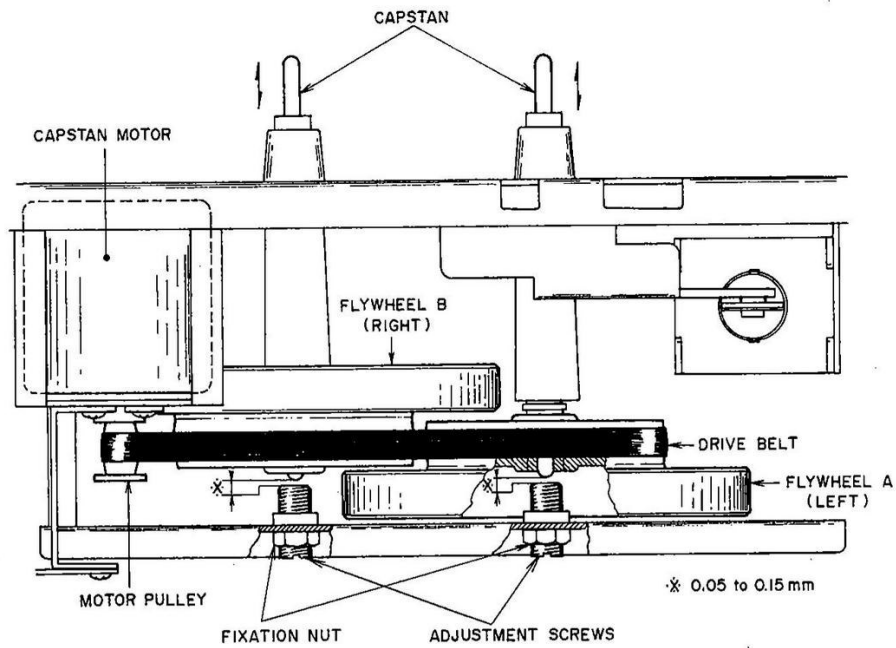

Fig. 4 Flywheel Thrust Loose Play Adjustment

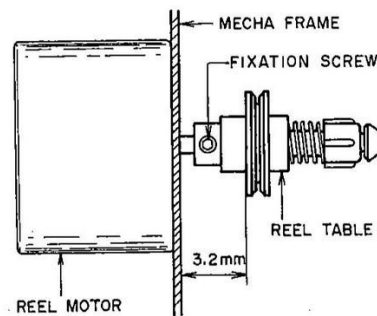

Fig. 5

1. FLYWHEEL THRUST LOOSE PLAY ADJUSTMENT (Refer to Fig. 4)

Adjust by turning flywheel thrust loose play adjustment screws to obtain a 0.05 to 0.15 mm of loose play when the flywheel is moved as indicated by the arrow mark.

Tighten fixation nuts to maintain optimum adjusted condition. Paint lock the adjustment screws.

2. REEL TABLE INSTALLATION POSITION ADJUSTMENT (Refer to Fig. 5)

Adjust until a clearance of approximately 3.2 mm is obtained between the mecha frame and the lower side of the reel table's pulley as shown in Fig. 5. Then, tighten the fixation screw firmly.

VI. MECHANISM ADJUSTMENTS

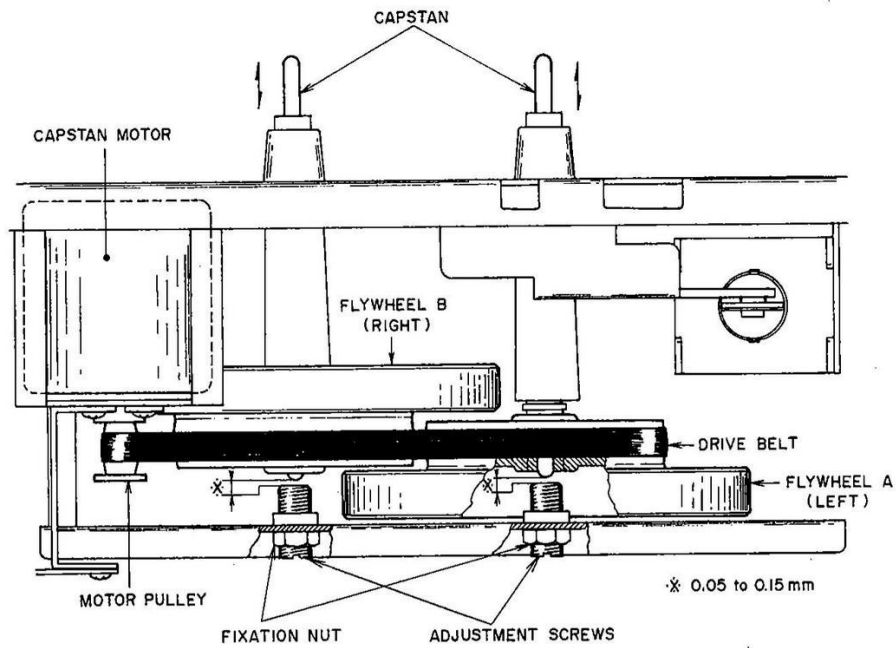

Fig. 4 Flywheel Thrust Loose Play Adjustment

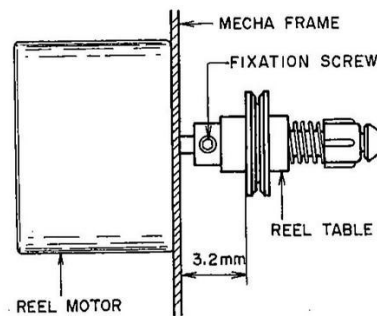

Fig. 5

1. FLYWHEEL THRUST LOOSE PLAY ADJUSTMENT (Refer to Fig. 4)

Adjust by turning flywheel thrust loose play adjustment screws to obtain a 0.05 to 0.15 mm of loose play when the flywheel is moved as indicated by the arrow mark.

Tighten fixation nuts to maintain optimum adjusted condition. Paint lock the adjustment screws.

2. REEL TABLE INSTALLATION POSITION ADJUSTMENT (Refer to Fig. 5)

Adjust until a clearance of approximately 3.2 mm is obtained between the mecha frame and the lower side of the reel table's pulley as shown in Fig. 5. Then, tighten the fixation screw firmly.

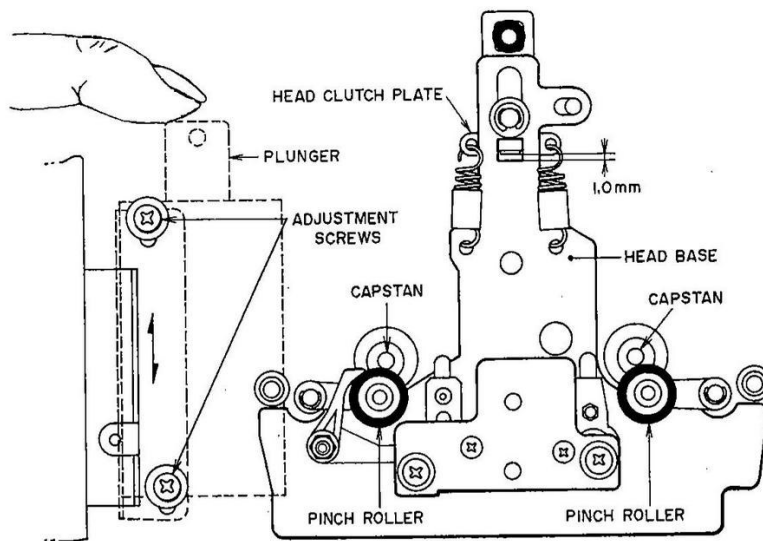

Fig. 6

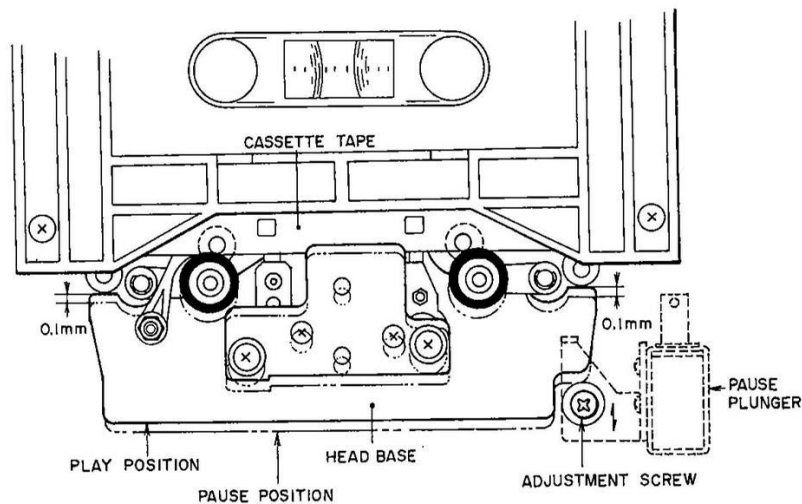

Fig. 7

3. PLAY PLUNGER INSTALLATION POSITION ADJUSTMENT (Refer to Fig. 6)

The clearance between the head base and head clutch plate when the plunger is moved as indicated in Fig. 6 at stop mode should be approximately 1.0 mm. If not, adjust play plunger position with the adjustment screws in the direction as indicated by the arrow mark.

4. PAUSE PLUNGER INSTALLATION POSITION ADJUSTMENT (Refer to Fig. 7)

With the tape loaded, the Pause Plunger Solenoid is not completely pulled if the head base does not lower at all when the mode is changed from PLAY to PAUSE. In order to allow Pause Plunger to function completely and still have the head not lowered too much, the head base should lower only 0.1 mm (lower only slightly) when the mode is changed from PLAY to PAUSE as shown in Fig. 7.

If you find that the plunger function is not complete, adjust by lowering the Pause Plunger Installation Position approximately 0.1 mm using the adjustment screw.

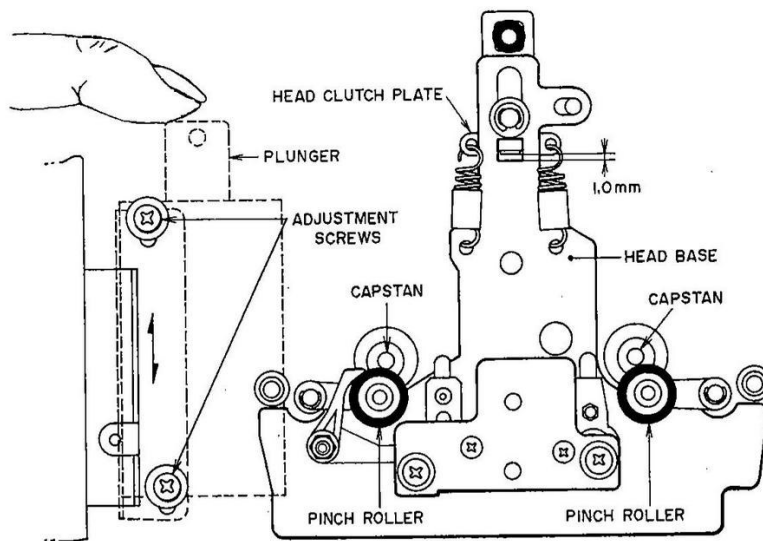

Fig. 6

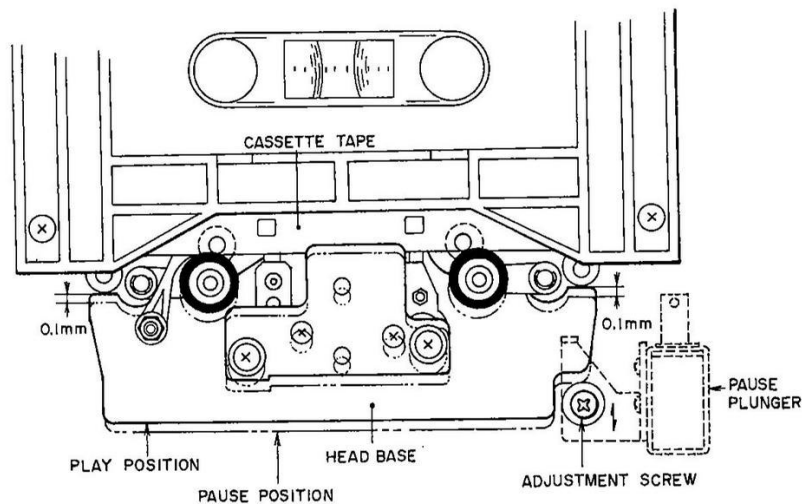

Fig. 7

3. PLAY PLUNGER INSTALLATION POSITION ADJUSTMENT (Refer to Fig. 6)

The clearance between the head base and head clutch plate when the plunger is moved as indicated in Fig. 6 at stop mode should be approximately 1.0 mm. If not, adjust play plunger position with the adjustment screws in the direction as indicated by the arrow mark.

4. PAUSE PLUNGER INSTALLATION POSITION ADJUSTMENT (Refer to Fig. 7)

With the tape loaded, the Pause Plunger Solenoid is not completely pulled if the head base does not lower at all when the mode is changed from PLAY to PAUSE. In order to allow Pause Plunger to function completely and still have the head not lowered too much, the head base should lower only 0.1 mm (lower only slightly) when the mode is changed from PLAY to PAUSE as shown in Fig. 7.

If you find that the plunger function is not complete, adjust by lowering the Pause Plunger Installation Position approximately 0.1 mm using the adjustment screw.

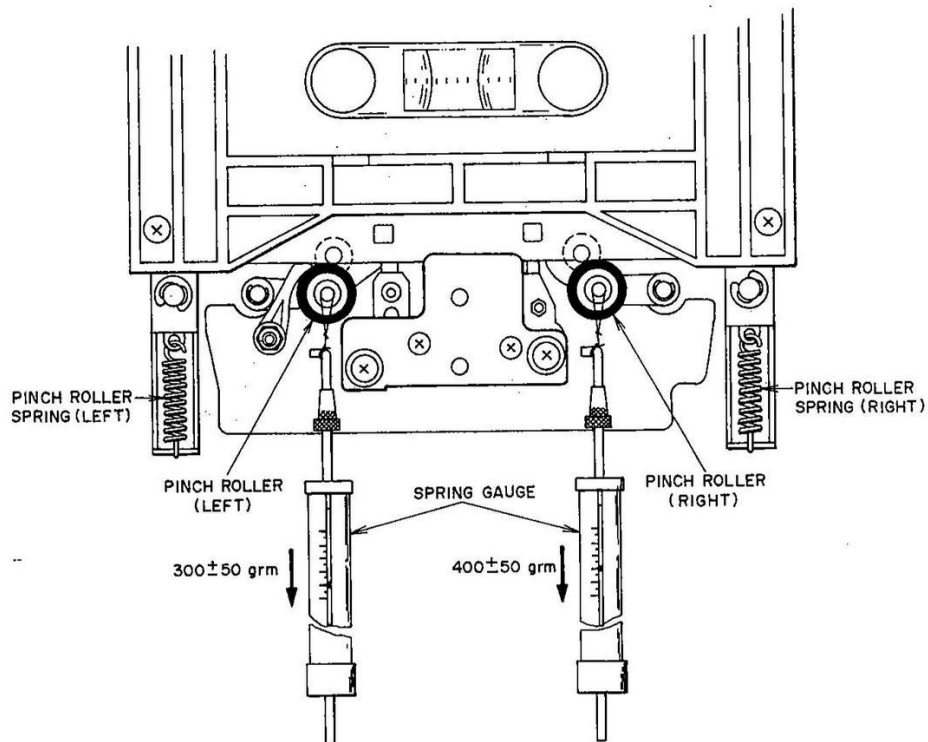

Fig. 8

5. PINCH ROLLER PRESSURE ADJUSTMENT (Refer to Fig. 8)

Load a cassette tape, set the recorder in the play mode, then pass a string around the pinch roller shaft and the spring gauge as shown in Fig. 8. Pull the spring gauge as indicated by the arrow mark in the figure until the pinch roller separates from the capstan. Then, gradually weaken the pulling force, and the spring gauge value when the pinch roller comes in contact with the capstan once again to start rotating. If the measurement value does not comply with the following values specified, replace the pinch roller spring.

Specified Pinch Roller Pressure:

Pinch Roller (Right) 400 ± 50 gm
Pinch Roller (Left) 300 ± 50 gm

NOTE: To pass a string around the pinch roller shaft, remove the two operation Button Fixation Screws and pull out the Operation Button Block. From the bottom of the chassis, pass the string behind the Operation Button Block and place it around the pinch roller shaft. Make sure that the string does not come in contact with the chassis or any other parts during the measurement.

6. TAKE-UP TORQUE AT VARIOUS MODES AND TORQUE MEASURING METHOD

Set a cassette torque meter on cassette base, and take a reading of the indication at each respective mode.

Playback mode	33 to 55 gm-cm
Fast Forward mode	80 to 120 gm-cm
Rewind mode	80 to 120 gm-cm

7. LID PANEL POSITION ADJUSTMENT (Refer to Fig. 9)

In case the lid panel is not parallel with the front panel, adjust by shifting the eject guide as indicated by the arrow mark in Fig. 9. If the upper part of the lid panel is tilted inward, move the eject guide upward, and if tilted outward, move the eject guide downwards.

8. TAPE SPEED ADJUSTMENT (Refer to Fig. 10)

Playback a 1,000 Hz pre-recorded test tape and adjust tape speed adjustment volume to obtain a tape speed of 1,000 Hz $\pm 2\%$.

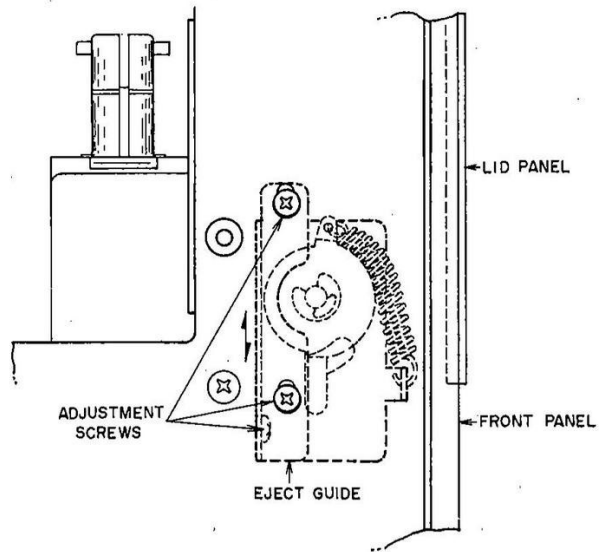

Fig. 9 Left Side of the Deck

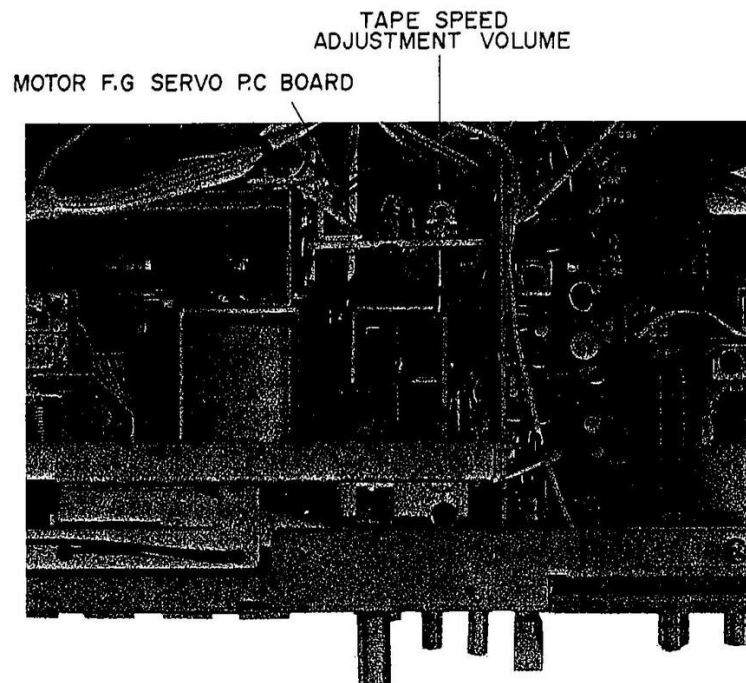

Fig. 10 Tape Speed Adjustment

VII. HEAD ADJUSTMENTS

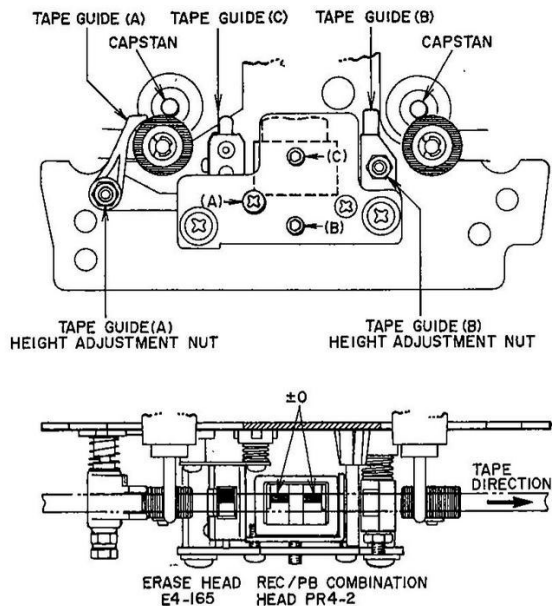

Fig. 11

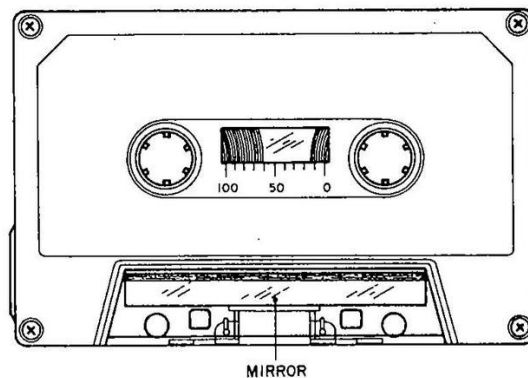

Fig. 12

1. TAPE GUIDE HEIGHT ADJUSTMENT

(Refer to Figs. 11, 12)

- 1) When using an ordinary cassette, the tape guides and heads, etc. are not visible. As shown in Fig. 12 use a cassette tape from which part of the cassette case has been cut out and a mirror installed for easy visibility of the head area when making tape guide height adjustment.
- 2) At playback mode, using the erase head guide (C) shown in Fig. 11 as standard for height, adjust tape guide (A) and tape guide (B) height with tape guide height adjustment nuts so that the tape runs smoothly and does not catch on the tape guides.

2. HEIGHT ADJUSTMENT OF RECORDING/PLAYBACK COMBINATION HEAD

(Refer to Fig. 11)

- 1) Utilize the cassette tape used in Tape Guide Height Adjustment above, and playback the leader tape part of cassette tape.
- 2) As shown in Fig. 11 adjust head height with screws (A), (B) and (C) until the upper edge of the tape is the same height as the upper edge of the left channel REC/PB Combination head core.

3. AZIMUTH ALIGNMENT ADJUSTMENT OF RECORDING/PLAYBACK COMBINATION HEAD

(Refer to Fig. 11)

- 1) The cores of recording and playback heads are mounted in a single head holder to form the recording/playback combination head otherwise known as the New GX Head. Both recording and playback head cores move when azimuth alignment is adjusted. To obtain optimum playback head core azimuth alignment, follow the instructions 2) – 5) carefully.
- 2) Playback a 10 kHz azimuth alignment adjustment test tape and adjust the adjustment screw (A) until the output level of both channels are at maximum.
- 3) Invert cassette and see whether there is an output level difference from the above. If there is a difference, repeat 2) and readjust.
- 4) Record a 10 kHz, -20 VU signal from the audio frequency oscillator.
- 5) Rewind and check for any fluctuation in the output level at playback.

NOTES: 1. Be sure to clean the heads prior to head adjustment.

2. Be careful not to use a magnetized driver or other magnetized tools in the vicinity of the heads.

3. Be sure to demagnetize the heads with a Head Demagnetizer before and after head adjustment.

4. When a mirror installed cassette test tape as shown in Fig. 12 is required, it can be ordered from AKAI Electric Co.

VIII. AMPLIFIER ADJUSTMENTS

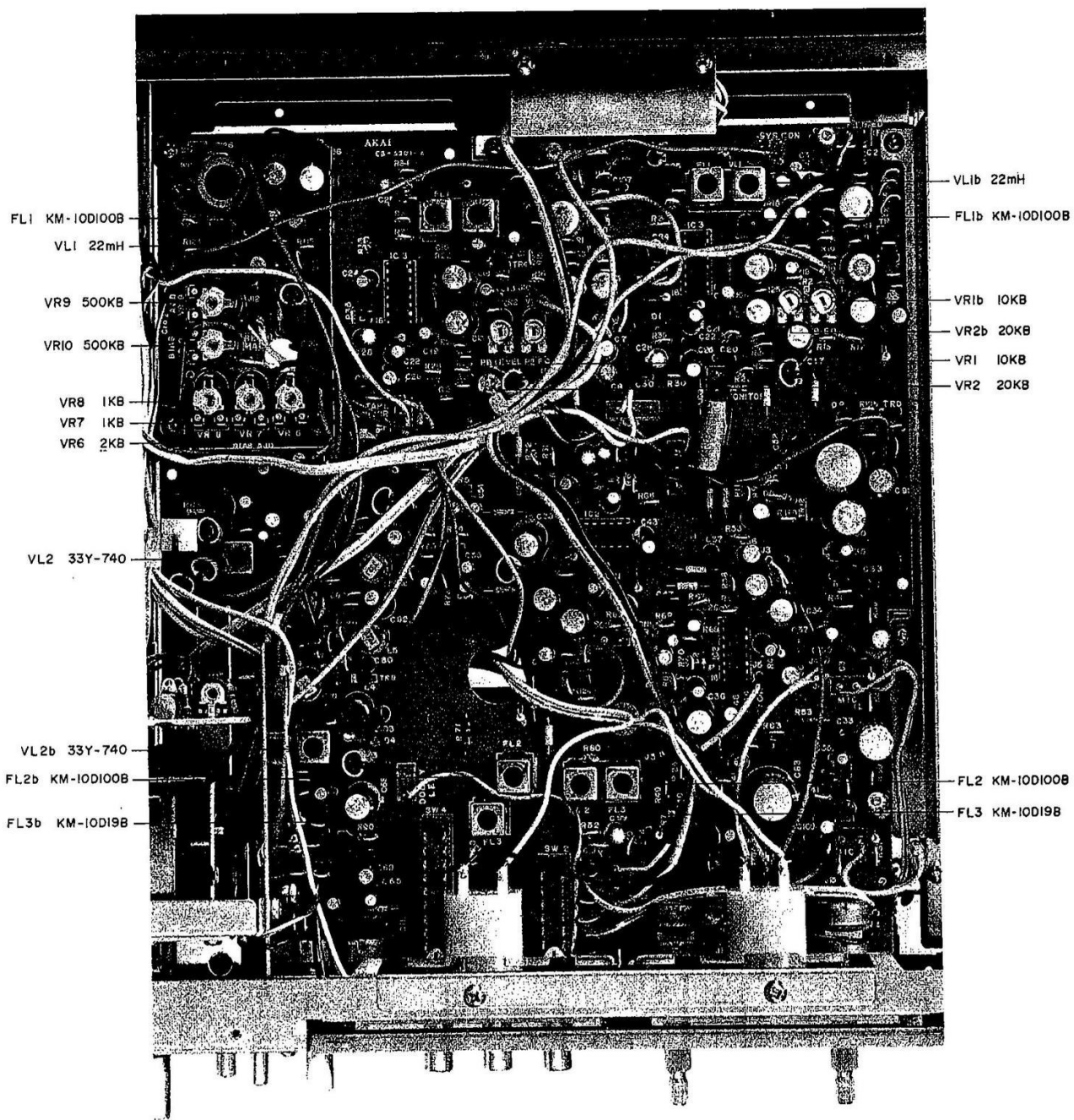

Fig. 13 Pre Amp P.C Board CB-5201A

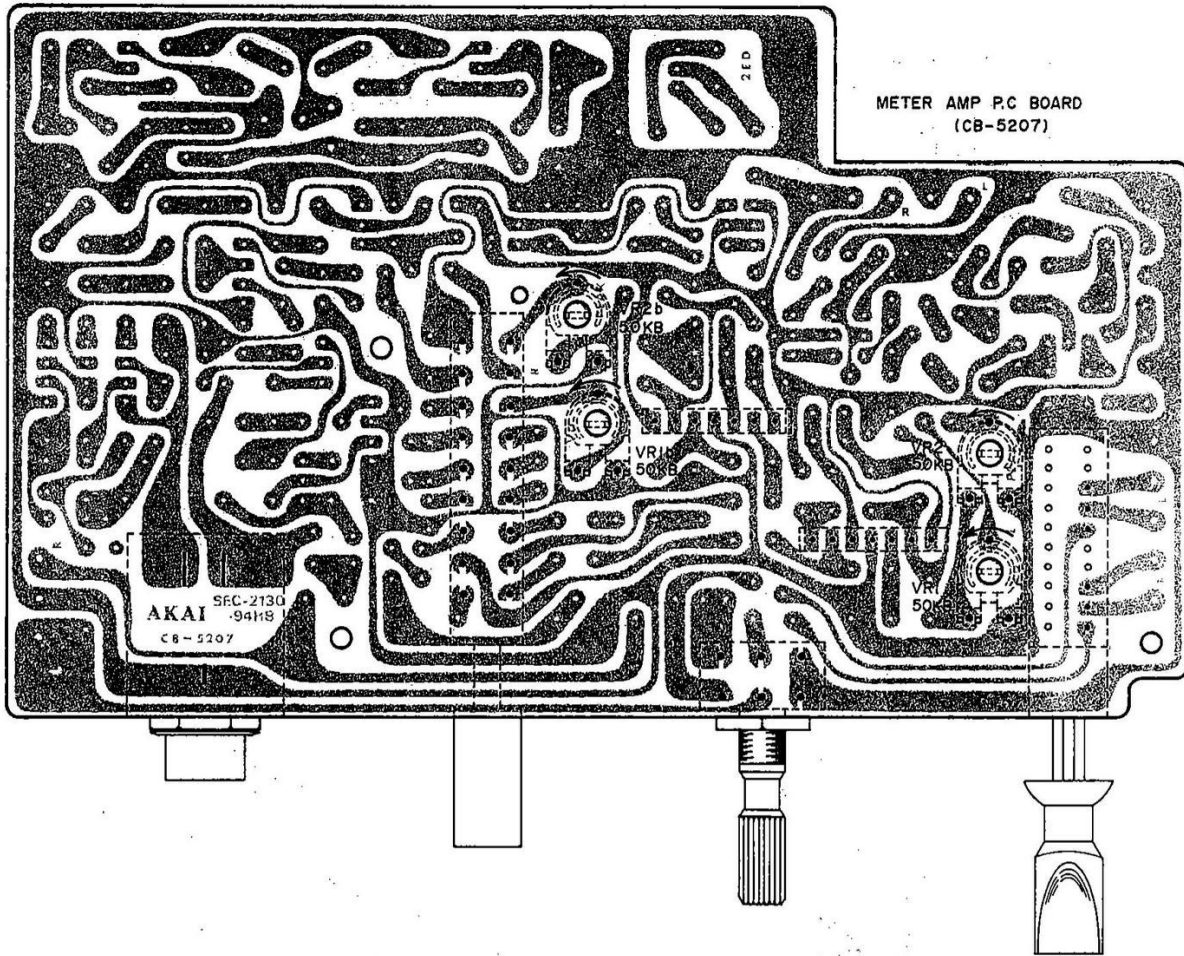

Fig. 14 Meter Sensitivity Adjustment

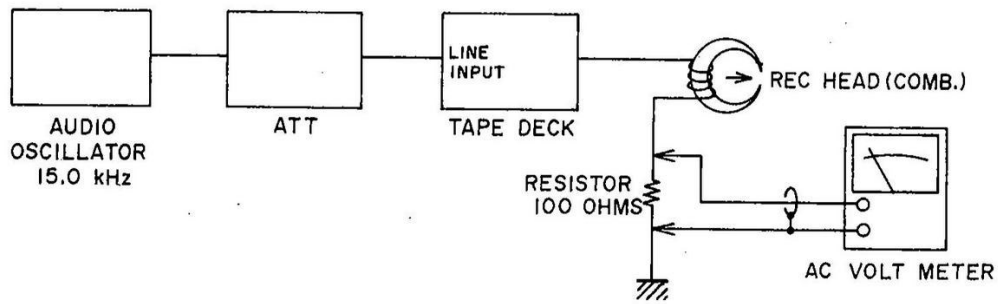

Fig. 15 Instruments Connections

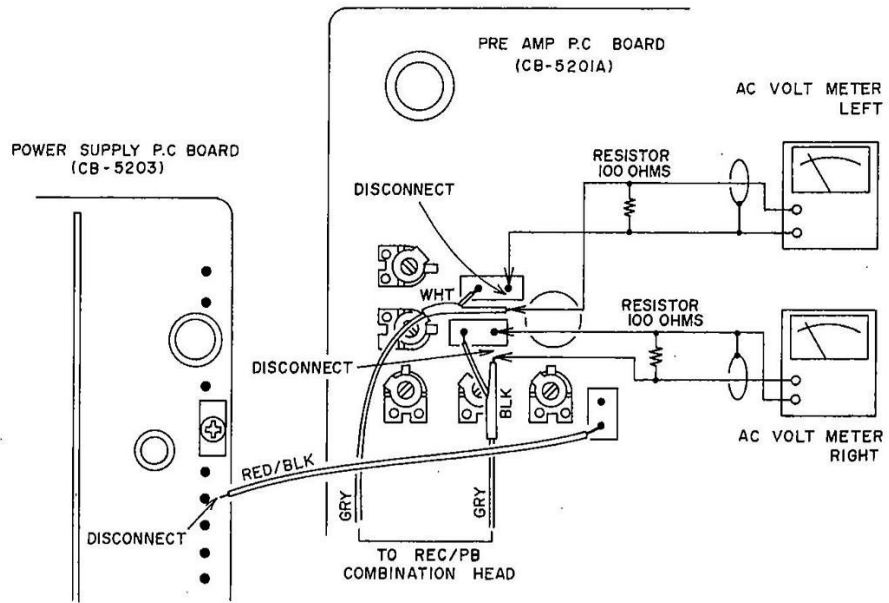

Fig. 16 Rec Peaking Adjustment

Step	Adjustment Item	Test Tape Supply Signal	Mode	Adjustment Point	Result	Remark
1	Playback Level Adjustment	333 Hz, 0 VU Test Tape	PLAY	VR2 20 kB	-5.5 dBm ±0.5 dBm	Set Monitor Switch to "TAPE"
2	VU Meter Sensitivity Adjustment	1,000 Hz, 0 VU from an Oscillator	STOP	VR1 50 kB (CB-5207)	0 VU Indication	Set Monitor Switch to "SOURCE" Set Meter Selector Switch to "VU"
3	Peak Meter Indication Adjustment	1,000 Hz, 0 VU from an Oscillator	STOP	VR2 50 kB (CB-2507)	-8 VU Indication	Set Meter Selector Switch to "PEAK"
4	PB Equalizer Adjustment	10 kHz Test Tape	PLAY	VR1 10 kB (CB-5201A)	-19.5 dBm	Set Monitor Switch to "TAPE"
5	CrO ₂ Position Frequency Response Adjustment	CrO ₂ blank tape, 1,000Hz, 10,000 Hz, -20 VU Recording	REC/PLAY	VR9 500 kB (LEFT) VR10 500 kB (RIGHT) (CB-5201A)	1,000 Hz to 10,000 Hz flat response	Set Tape Selector Switch to "CrO ₂ "
6	LN Position Frequency Response Adjustment	LN blank tape, 1,000 Hz, 10,000 Hz, -20 VU Recording	REC/PLAY	VR6 2 kB (CB-5201A)	1,000 Hz to 10,000 Hz flat response	Set Tape Selector Switch to "LN" (Refer to NOTE 4)
7	LH Position Frequency Response Adjustment	LH blank tape, 1,000 Hz, 10,000 Hz, -20 VU Recording	REC/PLAY	VR7 1 kB (CB-5201A)	1,000 Hz to 10,000 Hz flat response	Set Tape Selector Switch to "LH" (Refer to NOTE 4)
8	Fe-Cr Position Frequency Response Adjustment	Fe-Cr blank tape, 1,000 Hz, 10,000 Hz, -20 VU recording	REC/PLAY	VR8 1 kB (CB-5201A)	1,000 Hz to 10,000 Hz flat response	Set Tape Selector Switch to "Fe-Cr" (Refer to NOTE 4)
9	Recording Level Adjustment	LN blank tape, 1,000 Hz 0 VU Recording	REC/PLAY	VR3 (Front Panel)	-5.5 dBm ±0.5 dBm	(Refer to NOTE 5)
10	Distortion Factor Confirmation	1,000 Hz 0 VU Recording	REC/PLAY		CrO ₂ : Less than 1.5% LN: Less than 1.0% LH: Less than 1.0% Fe-Cr: Less than 1.5%	(Refer to NOTE 6)
11	Rec Peaking Adjustment	15.0 kHz from an oscillator	REC	VL2 33Y-740	Maximum AC Voltmeter indication	(Refer to NOTES 9, 10 and Figs. 15, 16)
12	Rec Amp Bias Leak Adjustment	100 kHz from an oscillator	REC	FL2 KL10D 100B (CB-5201A)	Minimum AC Voltmeter indication	Set Monitor Switch to "SOURCE" (Refer to NOTE 9)

Step	Adjustment Item	Test Tape Supply Signal	Mode	Adjustment Point	Result	Remark
13	19 kHz Filter Adjustment	19 kHz from an oscillator	STOP	FL3 KM10D 19B (CB-5201A)	Minimum AC Voltmeter indication	Set MPX Filter Switch to "ON" (Refer to NOTE 9)
14	PB Amp Bias Filter Adjustment	No Signal Input	REC/ PLAY	VL1 22mH (CB-5201A)	Minimum AC Voltmeter indication	Set Monitor Switch to "TAPE"
15	PB Amp Bias Filter Adjustment	No Signal Input	REC/ PLAY	FL1 KM10D 100B (CB-5201A)	Minimum AC Voltmeter indication	Set Monitor Switch to "TAPE"

Chart-2

- NOTES:**
1. Except for Steps 5, 7 and 8 set Tape Selector to LN position.
 2. Set Dolby N.R. switch, Cal. Tone Switch to OFF position.
 3. Except for Step 13, set MPX Filter switch to OFF position.
 4. If a flat characteristic cannot be obtained from 1,000 Hz to 10,000 Hz at LN, LH, or Fe-Cr positions, fine adjust at VR6 (LN), VR7 (LH), VR8 (Fe-Cr) respectively.
 5. Recording level adjustment volumes (REC CAL) VR3 are not located on the pre amp P.C Board as in the case of an ordinary tape deck, but are installed on the front panel.
 6. If it does not comply with the specifications, repeat Steps 5 – 9 and re-adjust.
 7. Because each of these adjustments are vital to perfect Dolby N.R. circuit operation, be sure that they are carried out with as little error as possible.
 8. Use the following cassette measuring tape:
 - LN Tape: Fuji FL C-60, AKAI C-60LN
 - LH Tape: Maxell UD C-60
 - CrO₂ Tape: TDK SA C-60
 - Fe-Cr Tape: SONY Duad C-60
 9. Unless the core is moved intentionally this adjustment is not necessary.
 10. Stop recording Bias Oscillator while making Rec Peaking Adjustment. (Refer to Figs. 15, 16)

IX. DC RESISTANCE OF VARIOUS COILS

Parts	Designation	DC Resistance
Recording/Playback Combination Head	PR4-2	REC: 22 ohms $\pm 5\%$ PB: 250 ohms $\pm 5\%$
Erase Head	E4-165	2.5 ohms
Play Plunger	1254 TLT	120 ohms $\pm 10\%$
Pause Plunger	P-120F	540 ohms $\pm 10\%$

Chart-3

X. CLASSIFICATION OF VARIOUS P.C BOARDS

1. RELATION OF P.C BOARD TITLE AND IDENTIFICATION NUMBER

P.C Board Title	P.C Board Number
Pre Amp P.C Board	CB-5201A
Dolby Lamp P.C Board	CB-5201B
Sys. Con P.C Board	CB-5202
Power Supply P.C Board	CB-5203
Noise Filter P.C Board	CB-5204
Lamp P.C Board	CB-5205
Meter Amp P.C Board	CB-5207
Housing Lamp P.C Board	CI-5237

Chart-4

2) SYS. CON P.C BOARD CB-5202 and NOISE FILTER P.C BOARD CB-5204

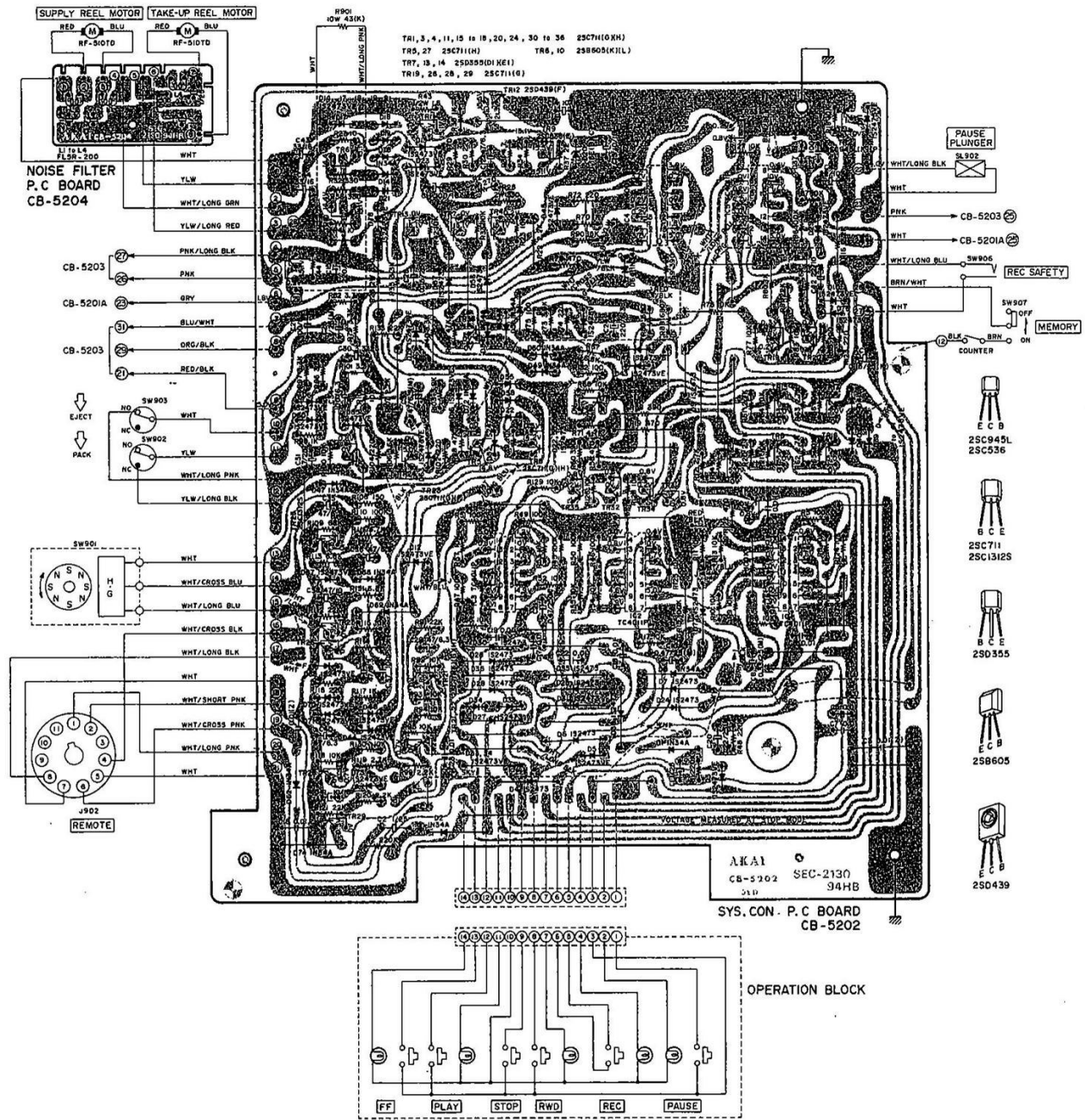

3) METER AMP P.C BOARD CB-5207

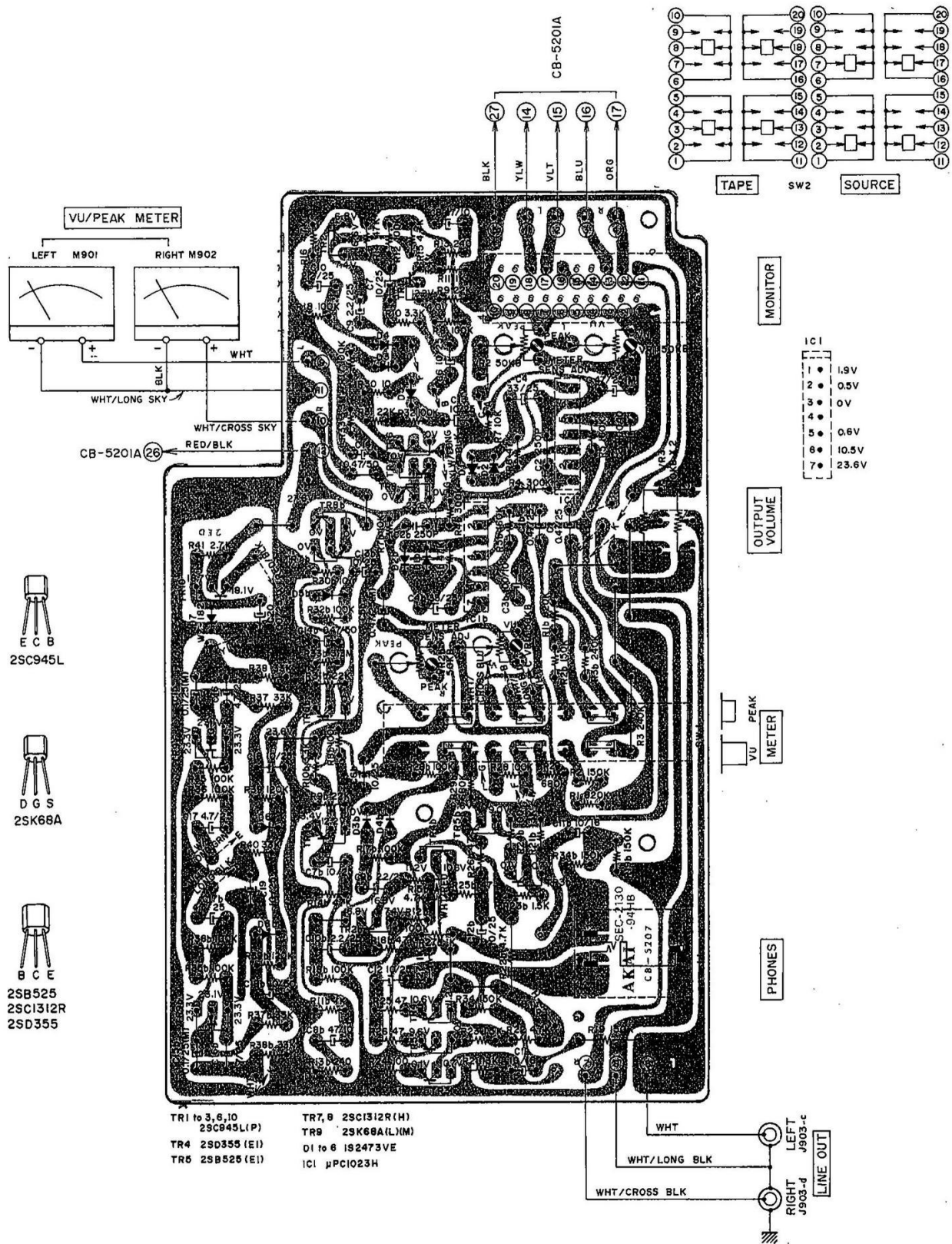

4) POWER SUPPLY P.C BOARD CB-5203 (U/T, CEE, BEAB)

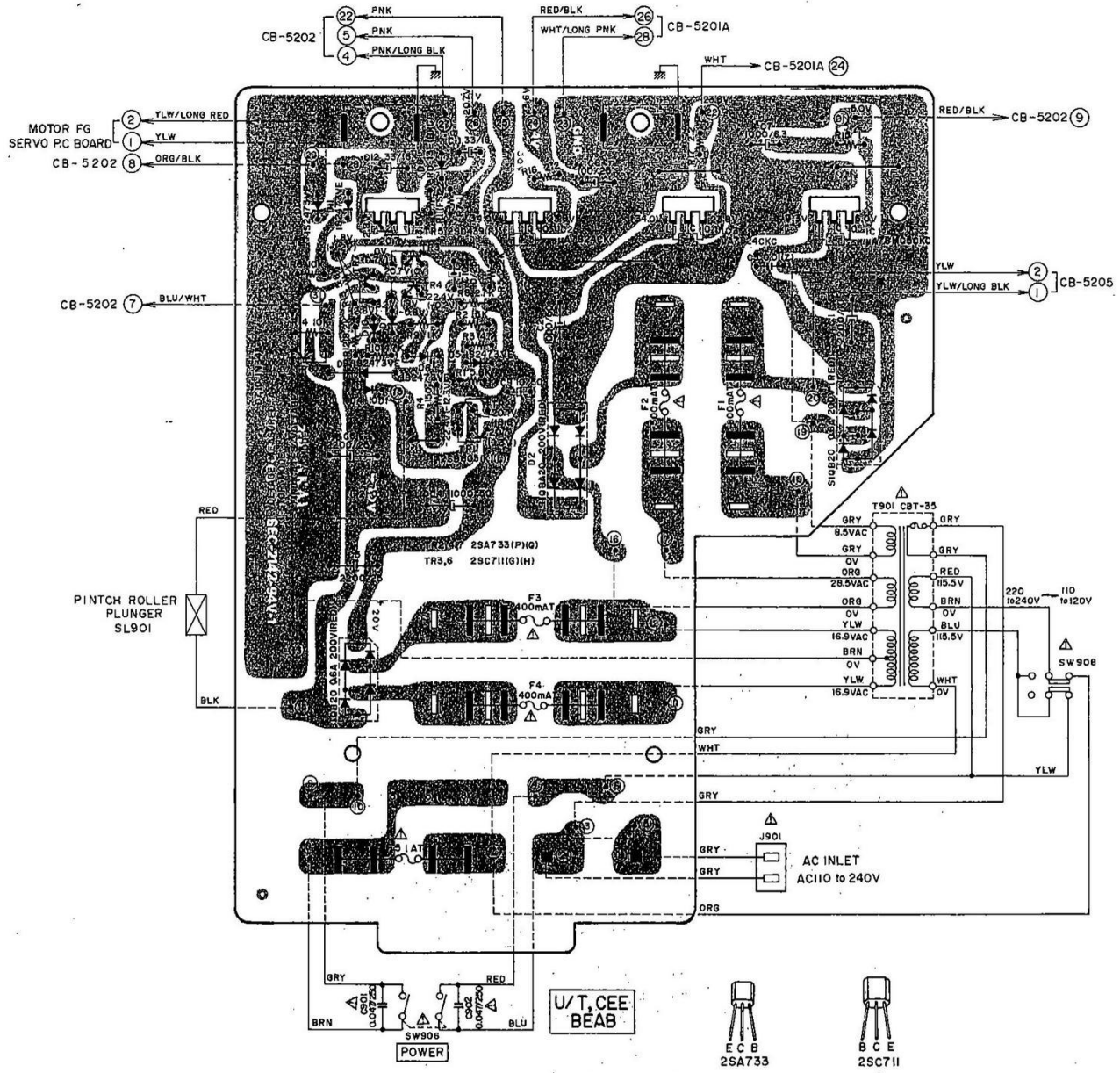

WARNING: △ INDICATES SAFETY CRITICAL COMPONENTS. FOR CONTINUED SAFETY, REPLACE SAFETY CRITICAL COMPONENTS ONLY WITH MANUFACTURER'S RECOMMENDED PARTS

AVERTISSEMENT: △ IL INDIQU LES COMPOSANTS CRITIQUES DE SÛRETÉ. POUR MAINTENIR LE DEGRÉ DE SÛRETÉ DE L'APPAREIL NE REMPLACER LES COMPOSANTS DONT LE FONCTIONNEMENT EST CRITIQUE POUR LA SÛRETÉ QUE PAR DES PIÈCES RECOMMANDÉES PAR LE FABRICANT.

5) POWER SUPPLY P.C BOARD CB-5203 (CSA, AAL, JPN)

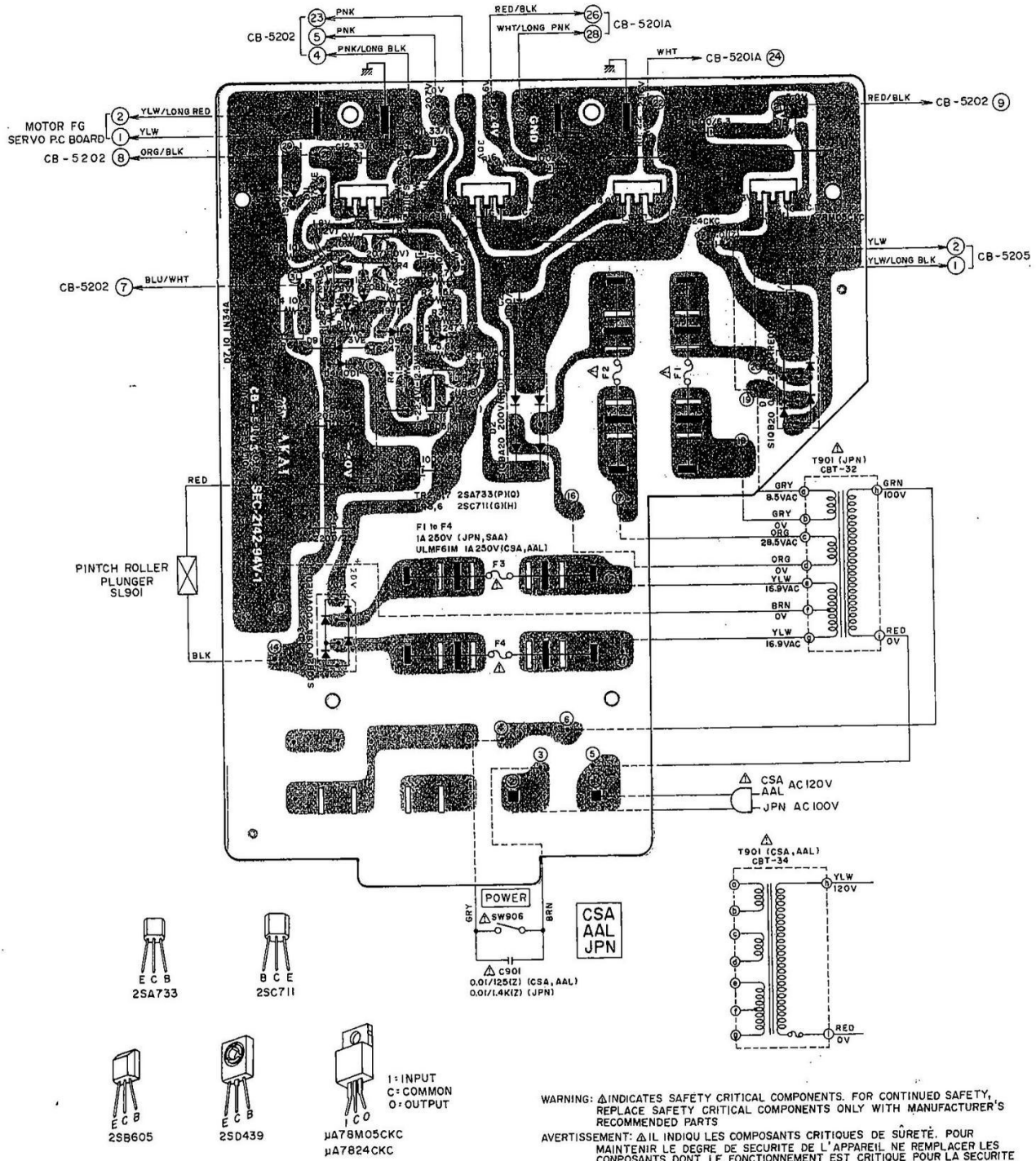

6) POWER SUPPLY P.C BOARD CB-5203 (SAA)

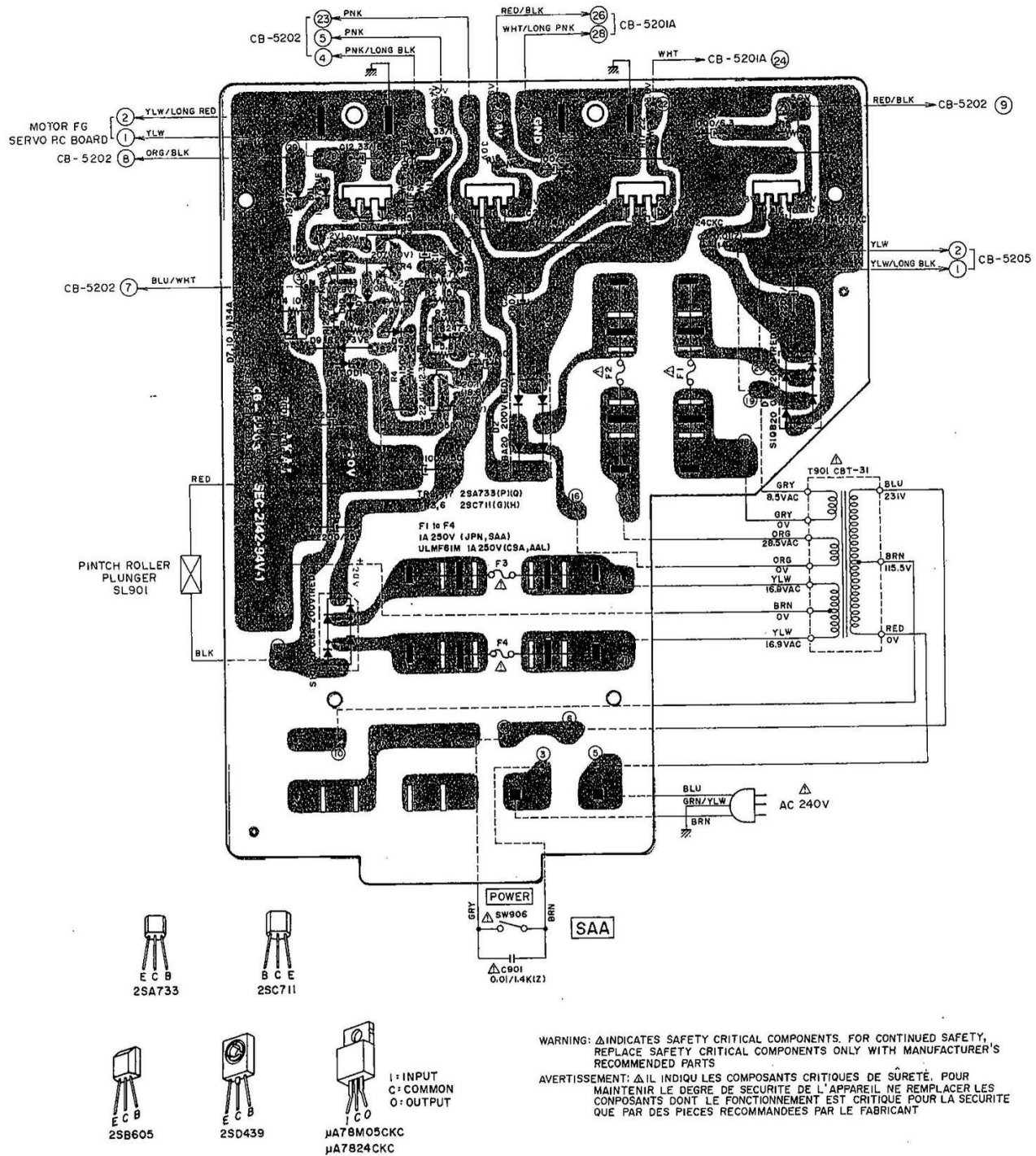

7) LAMP P.C BOARD CB-5205 and HOUSING LAMP P.C BOARD CI-5237

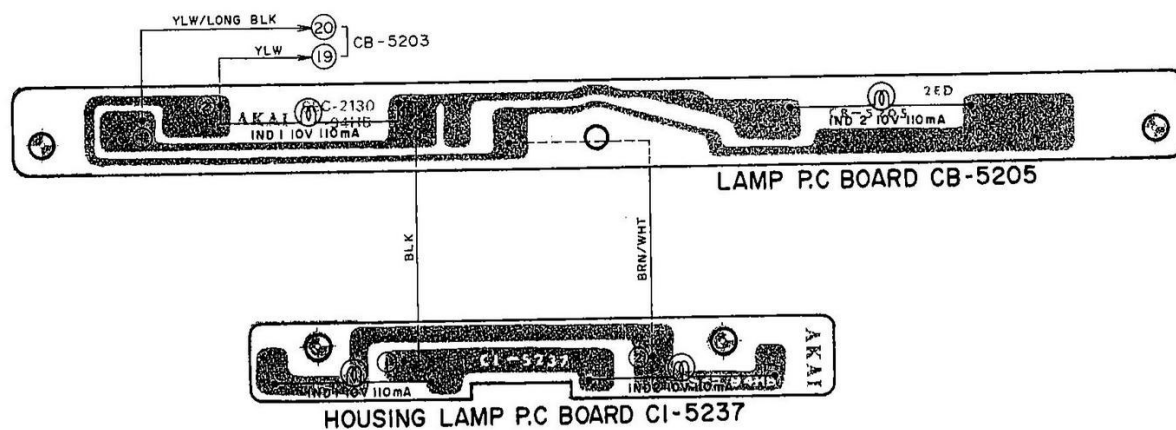

SECTION 2

PARTS LIST

TABLE OF CONTENTS

1. RECOMMENDED SPARE PARTS LIST	38
2. HEAD BASE BLOCK	40
3. REEL TABLE BLOCK	41
4. CASSETTE HOLDER BLOCK	42
5. MECHA FRAME BLOCK (1)	43
6. MECHA FRAME BLOCK (2)	44
7. P.C BOARDS	46
(1) PRE AMP P.C BOARD (CB-5201A) BLOCK	46
(2) SYS. CON P.C BOARD (CB-5202) BLOCK	47
(3) POWER SUPPLY P.C BOARD (CB-5203) BLOCK	48
(4) NOISE FILTER P.C BOARD (CB-5204) BLOCK	48
(5) METER AMP P.C BOARD (CB-5207) BLOCK	49
8. AMP ASSEMBLY BLOCK	50
9. FINAL ASSEMBLY BLOCK	52
10. LIST OF INTERCHANGEABLE SEMICONDUCTORS	53
INDEX	55

Resistor and Capacitor which is not listed in this parts list, please refer to COMMON LIST FOR SERVICE PARTS.

HOW TO USE THIS PARTS LIST

1. This parts list is compiled by various individual blocks based on assembly process.
2. When ordering parts, please describe parts number, serial number, and model number in detail.
3. How to read List

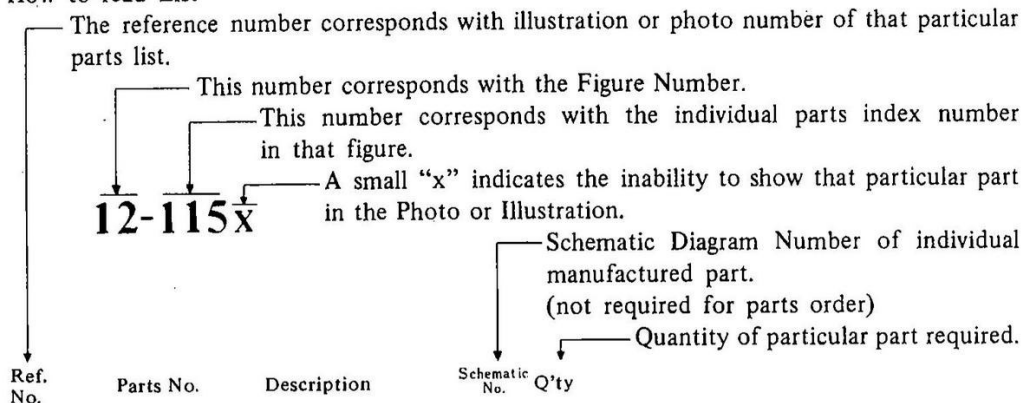

Ref. No.	Parts No.	Description	Schematic No.	Q'ty
FLYWHEEL BLOCK #13				
12-115x	800425	Flywheel Block Assy. Comp.	RDG #13	1
12-116	244506	Flywheel Only	RD-233	1
12-117x	244754	Felt, Flywheel	RD-275	1
12-118	251324	Main Metal Case	RD-236	1
12-119	253080	Main Metal	RD-237	1

4. The symbol numbers shown on the P.C. Board list can be matched with the Composite Views of Components of the Schematic Diagram or Service Manual.
5. Please utilize separate "Common List for Service Parts" for Resistor Parts orders.
6. The shape of the parts and parts name, etc. can be confirmed by comparing them with the parts shown on the Electrical Parts Table of P.C. Board.
7. Both the kind of part and installation position can be determined by the Parts Number. To determine where a parts number is listed, utilize Parts Index at end of Parts List.
It is necessary first of all to find the Parts Number. This can be accomplished by using the Reference Number listed at right of parts number in the Parts Index. (meaning of ref. no. outlined in Item 3 above).
8. Utilize separate "Price List for Parts" to determine unit price. The most simple method of finding parts Price is to utilize the reference number.

CAUTION:

1. When placing an order for parts, be sure to list the parts no., model no., and description. There are instances in which if any of this information is omitted, parts cannot be shipped or the wrong parts will be delivered.
2. Please be careful not to make a mistake in the parts no. If the parts no. is in error, a part different from the one ordered may be delivered.
3. Because parts number and parts unit supply in the Preliminary Service Manual (Basic Parts List) may be partially changed, please use this parts list for all future reference.

WARNING: ⚠ INDICATES SAFETY CRITICAL COMPONENTS. FOR CONTINUED SAFETY, REPLACE SAFETY CRITICAL COMPONENTS ONLY WITH MANUFACTURER'S RECOMMENDED PARTS.

AVERTISSEMENT: ⚠ IL INDIQU LES COMPOSANTS CRITIQUES DE SURETE. POUR MAINTENIR LE DEGRE DE SECURITE DE L'APPAREIL NE REMPLACER LES COMPOSANTS DONT LE FONCTIONNEMENT EST CRITIQUE POUR LA SECURITE QUE PAR DES PIECES RECOMMANDEES PAR LE FABRICANT.

AC INLET SYSTEM

This model is equipped with an AC INLET SYSTEM. Please refer to the AC INLET SYSTEM CHART below for the specific type. By the AC INLET SYSTEM, AC (mains) cord can be connected to and disconnected from the model because the model is provided with socket exclusively for AC (mains) cord on its main body.

Please note, however, that certain models are not equipped with this system and has a built-in AC (mains) cord as before.

AC INLET SYSTEM CHART

CLASS I

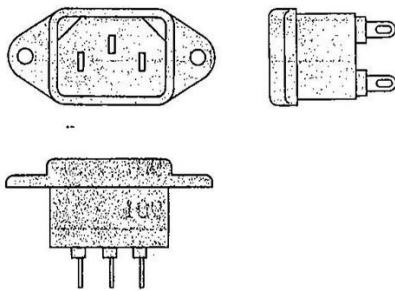

Picture 1
AC INLET
to be
installed
on machines

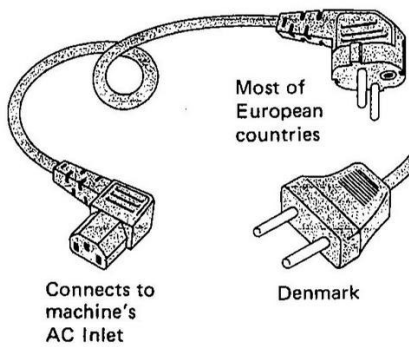

Most of
European
countries

Denmark

Connects to
machine's
AC Inlet



U.K.

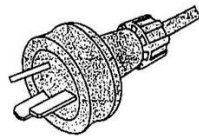

Australia
differs according
to wall socket

CLASS II

☐ This mark indicating double insulation will be attached to machine's rear panel

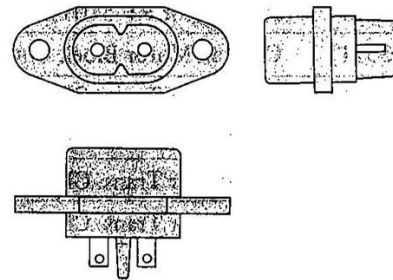

Connects to
machine's
AC Inlet

Most of the
European
countries

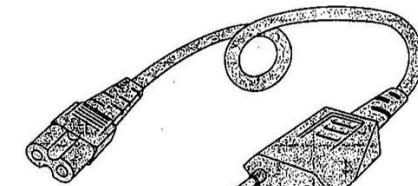

Picture 2
AC (mains)
cord

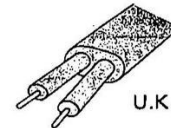

U.K.

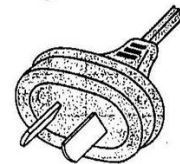

Australia
differs according
to wall socket

Parts List for AC (mains) Cord Set

	Standard	Description	Type of AC Inlet	Parts No.
Class I	CEE	Cord Set CEE (3 cores)	3P	EW302993
	BEAB	Cord Set BEAB (3 cores)	3P	EW302994
	SAA	Cord Set SAA (3 cores)	3P	EW302996
	U/T	Cord Set U/T (3 cores)	3P	EW302646
Class II	CEE	Cord Set CEE (2 cores)	2P	EW638144
	BEAB	Cord Set BEAB (2 cores)	2P	EW302995
	SAA	Cord Set SAA (2 cores)	2P	EW302991
	U/T	Cord Set U/T (2 cores)	2P	EW302899

1. RECOMMENDED SPARE PARTS LIST

Because, if the parts listed below are on hand, almost any repair can be accomplished, we suggest that you stock these Recommended Spare Parts Items.

Parts No.	Description	Note
BA304069	Pre Amp P.C Board Comp. GXC-750D	
BA304037	Sys. Con P.C Board Comp. GXC-750D	
BA304034	Power Supply P.C Board Comp. GXC-750D (U/T, CEE, BEAB)	
BA304035	Power Supply P.C Board Comp. GXC-750D (JPN, CSA, AAL, SAA)	
BA304036	Meter Amp P.C Board Comp. GXC-750D	
BA303612	Noise Filter P.C Board Comp. GXC-750D	
BM302507	Reel Motor RF-510TD	
BM303321	Capstan Motor Block Comp. GXC-750D	
BT303989	△ Power Trans. CBT-35 (U/T, CEE)	T901
BT302631	△ Power Trans. CBT-32 (JPN)	T901
BT302633	△ Power Trans. CBT-34 (CSA, AAL)	T901
BT303988	△ Power Trans. CBT-31 (SAA)	T901
ED624903	Silicon Diode 1S2473	
ED560913	Silicon Diode 1S2473VE	
ED224526	Silicon Diode 10D1	
ED249581	Silicon Diode SIQB20 0.6A 200V (RED)	
ED304658	Silicon Diode SIRBA20 200V (RED)	
ED219464	Germanium Diode 1N34A	
ED562397	Germanium Diode 1S188FM-1	
ED305239	Zener Diode WZ-182	
ED304656	Zener Diode RD-3E (B)	
ED304247	Zener Diode RD-13E (B) (C)	
ED304246	Zener Diode RD-16E (B) (C)	
ED557111	Zener Diode WZ-210	
ED283138	LED GL-3PG1	
EI669666	IC μ PC1023H	IC1 (CB-5207)
EI302623	IC TA-7139P	IC1 (CB-5201A)
EI301463	Dolby IC CR-713B	IC2, 3 (CB-5201A)
EI304190	IC TA-7140P	IC4 (CB-5201A)
EI304657	IC TC-4011P	IC1 to 3, 5 (CB-5202)
EI304165	IC MB400/7400	IC4 (CB-5202)
EI304173	IC μ A78M05CKC	IC1 (CB-5203)
EI304174	IC μ A7824CKC	IC2, 3 (CB-5203)
EL304025	Lamp (No. 2) 10V 110mA	
EP302445	Plunger Solenoid P-120F	
EP302690	Plunger Solenoid TDS-12E	
ES302940	Micro SW. SS-5GLC	SW902
ES305231	Micro SW. AH7450261	SW903
ES302448	Leaf SW. BSW-81	SW905
ES303985	Rotary Slide SW. SRZ-V104S	SW1 (CB-5201A)

Parts No.	Description	Note
ES691424	Lever SW. SLK04251	SW2 (CB-5207)
ES303986	Push SW. SUE-33	SW2 to 4 (CB-5201A)
ES303981	Push SW. SUE-12	SW1 (CB-5207)
ES665807	△ Push SW. SDG-5P 5A/80A 250V (U/T, CEE, BEAB)	SW906
ES293703	△ Push SW. SDV1P TV-5 (w/o label) (JPN, SAA, CSA)	SW906
ES280258	△ Push SW. SDV1P TV-5 (w/label) (AAL)	SW906
ES517410	Push SW. SPJ-10101	
ET554657	Transistor 2SA733 (P) (Q)	
ET304180	Transistor 2SA906 (H)	
ET302540	Transistor 2SB525 (E1)	
ET666415	Transistor 2SB605 (K) (L)	
ET563905	Transistor 2SC711 (G) (H)	
ET429748	Transistor 2SC711 (H)	
ET399870	Transistor 2SC711 (G)	
ET398777	Transistor 2SC711 (G) (F)	
ET621268	Transistor 2SC711 (F) (G) (H)	
ET639437	Transistor 2SC945L (Q) (P)	
ET635220	Transistor 2SC945L (K) (P)	
ET638504	Transistor 2SC945L (P)	
ET361923	Transistor 2SC536 (E)	
ET242684	Transistor 2SC1312S (H)	
ET539864	Transistor 2SC1312R (H)	
ET352146	Transistor 2SC458LG (D)	
ET304181	Transistor 2SC2002 (K)	
ET304167	Transistor 2SD439 (F)	
ET302538	Transistor 2SD355 (E1)	
ET655356	Transistor 2SD571 (L) (M)	
ET302300	Transistor 2SD355 (D2) (E1)	
ET669633	FET 2SK68A (L) (M)	
EV520806	Semi-fixed/Vol. V8K4-1 10k (B)	VR1 (CB-5201A)
EV522797	Semi-fixed/Vol. V8K4-1 20k (B)	VR2 (CB-5201A)
EV464220	Semi-fixed/Vol. V8K4-1 50k (B)	
EV269572	Semi-fixed/Vol. V10K8-4-2 2k (B)	VR6 (CB-5201A)
EV484863	Semi-fixed/Vol. V10K8-4-2 1k (B)	VR8 (CB-5201A)
EV499882	Semi-fixed/Vol. V10K8-4-2 300k (B)	VR9, 10 (CB-5201A)
EV303984	Vol. VM10R 10k (B)	VR3 (CB-5201A)
EV303987	Double axial 2 throw Vol. DM20R 100k(A) × 2	VR4, 5 (CB-5201A)
EV303982	Vol. CM70R 10k(B) × 2	VR3 (CB-5207)
EZ304894	Rotary SW. Assy GXC-750D	SW901
HE636963	ERASE HEAD E4-165	
HP671174	REC/PB HEAD PR4-2	
MB302211	Counter Belt	
MB302316	Capstan Belt	

2. ILLUSTRATION OF HEAD BASE BLOCK

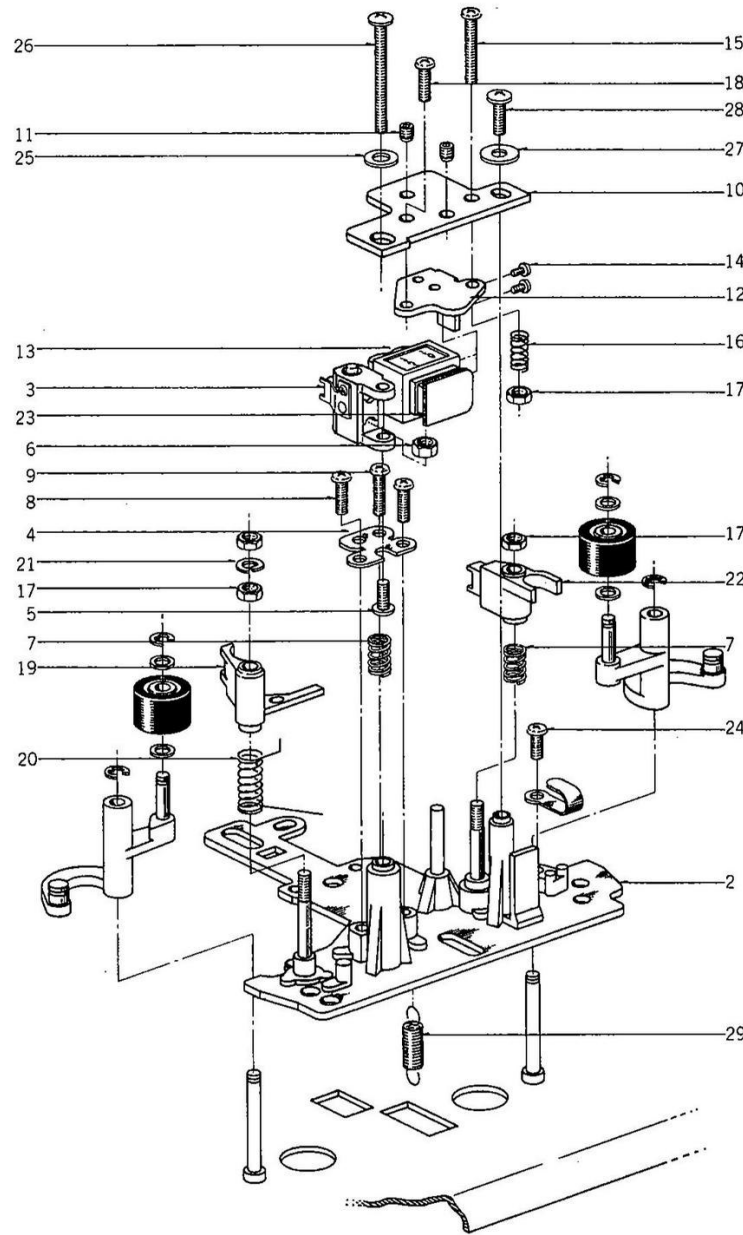

2) HEAD BASE BLOCK

Ref. No.	Parts No.	Description	Schematic No.	Ref. No.	Parts No.	Description	Schematic No.
2-1x	BH302650	Head Base Block Comp. GXC-570D-2		2-15	ZS670004	Screw, pan head 2.3x16	
2-2	HZ302385	Head Base Part-G	CI-201	2-16	ZS465636	Angle Adjust Spring	CG-0029
2-3	HE636963	ERASE HEAD E4-165		2-17	ZW591265	Nut M2.3, #3	
2-4	HZ227103	Erase Head Plate (B)	CA-0213	2-18	ZS487091	Screw, pan head 2.3x8	
2-5	ZS375118	Screw, binding head 2.3x6		2-19	HZ302181	Tape Guide (C)	CI-0207
2-6	ZW699052	Nut, M2.3 D2.3x5x2.3t		2-20	ZG302182	Guide Spring	CI-0208
2-7	ZG289236	Tape Guide Spring	CM-0005	2-21	ZW273666	Spring Washer, M2.3	
2-8	ZS522180	Tapping Screw #2, 2x8 (Pan)		2-22	TC286007	Tape Guide (B)	CM-0002
2-9	ZS302510	Screw, pan head 2x10		2-23	EA669510	PR4-1 Terminal P.C Board	CW-0045
2-10	HZ302183	Head Hanger (C)	CI-0209	2-24	ZS669104	Tapping Screw #2, 2.3x6 (Pan)	
2-11	ZS356804	Set Screw, hexagon socket 3x4 (CUP/P.)	CI-0205	2-25	ZW452395	Washer (SPC) D2.3x7x0.5t	
2-12	HZ302180	Head Mt. Parts		2-26	ZS302425	Head Hanger Screw	CI-0210
2-13	HP671174	REC/PB HEAD PR4-2		2-27	ZW550642	Washer (SPC) D3.1x8x0.5t	
2-14	ZS300626	Screw, pan head 2x2.5 (Camera Standard)		2-28	ZS300436	Tapping Screw #2, 2.3x8 (Bind)	
				2-29	ZG595506	Stop Spring	CH-3007

When ordering parts, please describe Parts Number, Description, and Model Number in detail.

3. ILLUSTRATION OF REEL TABLE BLOCK

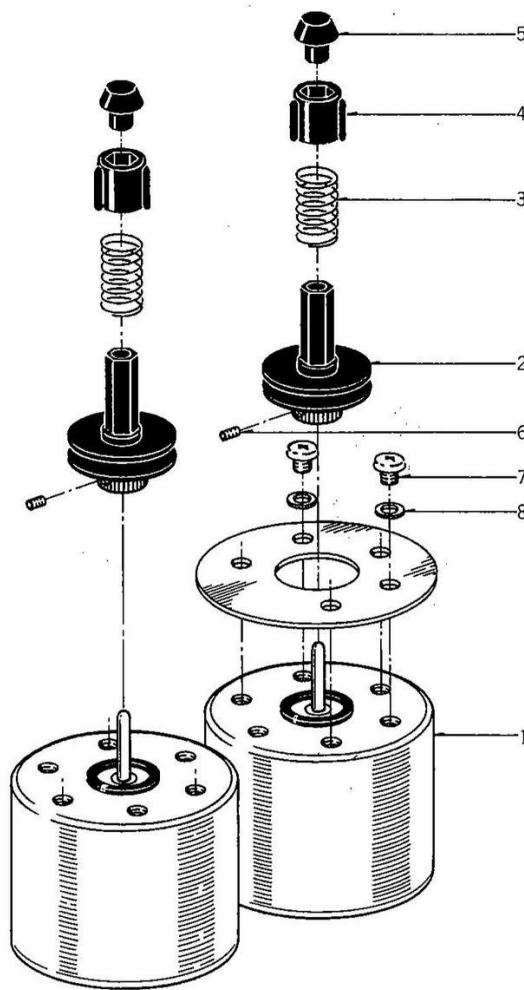

3) REEL TABLE BLOCK

Ref. No.	Parts No.	Description	Schematic No.
3-1	BM302507	Reel Motor RF-510TD	9-2-13
3-2	MT302244	Reel Table Part-G GI-2	CI-2205
3-3	ZG302350	Reel Table Spring	CI-2217
3-4	MT605766	Reel Table Blade (V Type)	CH-1070
3-5	MT667912	Reel Table Top	CB-2019
3-6	ZS302938	Set Screw, hexagon socket 2x3 (WP)	
3-7	ZS608174	Screw, pan head 2.6x3 (Take-up)	
3-8	ZW318014	Washer (BSP) D2.6x4.5x0.4t (Take-up)	

When ordering parts, please describe Parts Number, Description, and Model Number in detail.

4. ILLUSTRATION OF CASSETTE HOLDER BLOCK

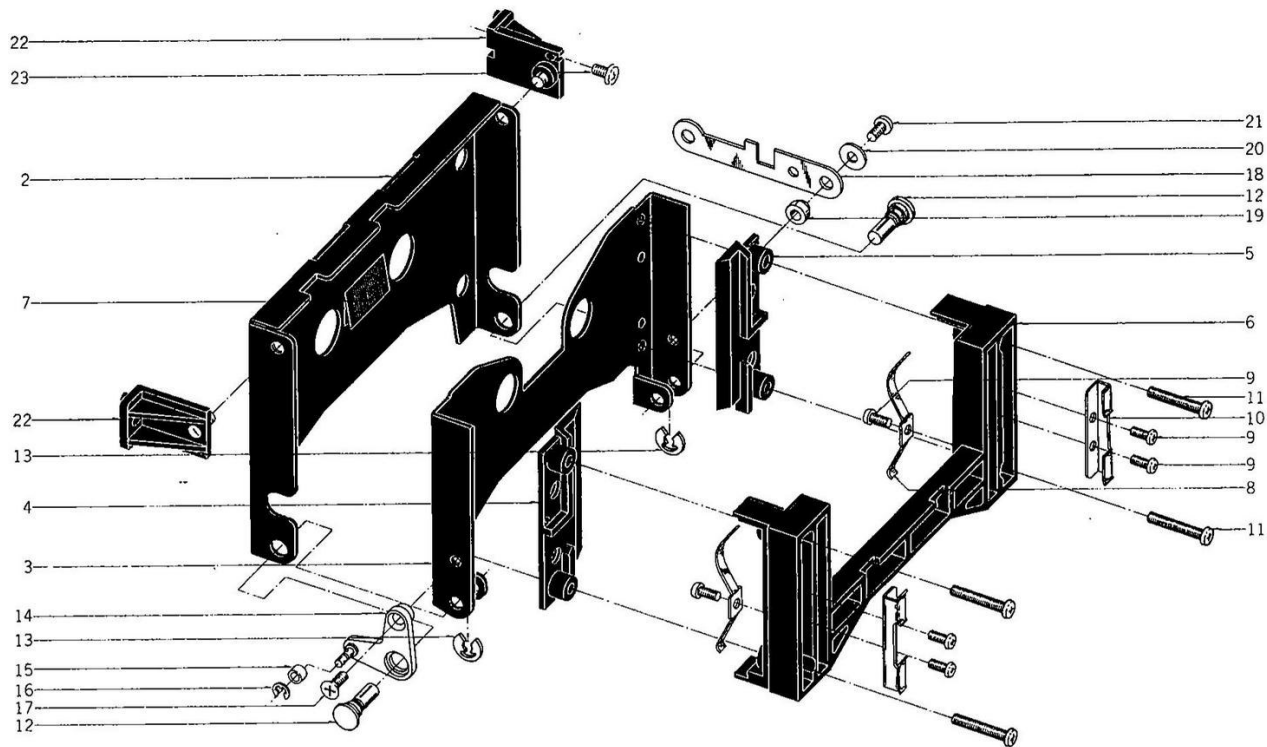

4) CASSETTE HOLDER BLOCK

Ref. No.	Parts No.	Description	Schematic No.
4-1x	BZ302234	Cassette Holder Block Comp. GXC-570D-2	
4-2	TC302245	Trap Part CI-2	CI-2211
4-3	TC292285	Cassette Holder	CA-2023
4-4	MS595563	Cassette Guide (L)	CH-2007
4-5	MS595552	Cassette Guide (R)	CH-2006
4-6	TC647065	Cassette Case	CA-2024
4-7	TC645186	Reflector	CA-2071
4-8	ZG305459	Sheet Spring (C)	CI-2019
4-9	ZS669104	Tapping Screw #2, 2.3x6 (Pan)	
4-10	TC642148	Lid Chuck	CA-2026
4-11	ZS592402	Screw, pan head 3x18	
4-12	MH644916	Hinge Pin	CA-2028
4-13	ZW290283	'U' Ring 2.85M	6-1-1
4-14	ML302246	Eject Guide Arm Part CI-2	CI-2212
4-15	MR305435	Roller	CB-2225
4-16	ZW270088	'E' Ring 1.9M	6-1-9
4-17	ZS414033	Screw, countersunk head 3x8	
4-18	MZ302311	Joint	CI-1249
4-19	MH302312	Sleeve	CI-1250
4-20	ZW550642	Washer (SPC) D3.1x8x0.5t	
4-21	ZS379350	Screw, pan head 3x6	
4-22	TC302142	Stand Part-G GXC-570D-2	CI-1220
4-23	ZS323728	Screw, binding head 3x5	
4-24x	ZW270101	'E' Ring 3M	6-1-9

When ordering parts, please describe Parts Number, Description, and Model Number in detail.

5. ILLUSTRATION OF MECHA FRAME BLOCK (1)

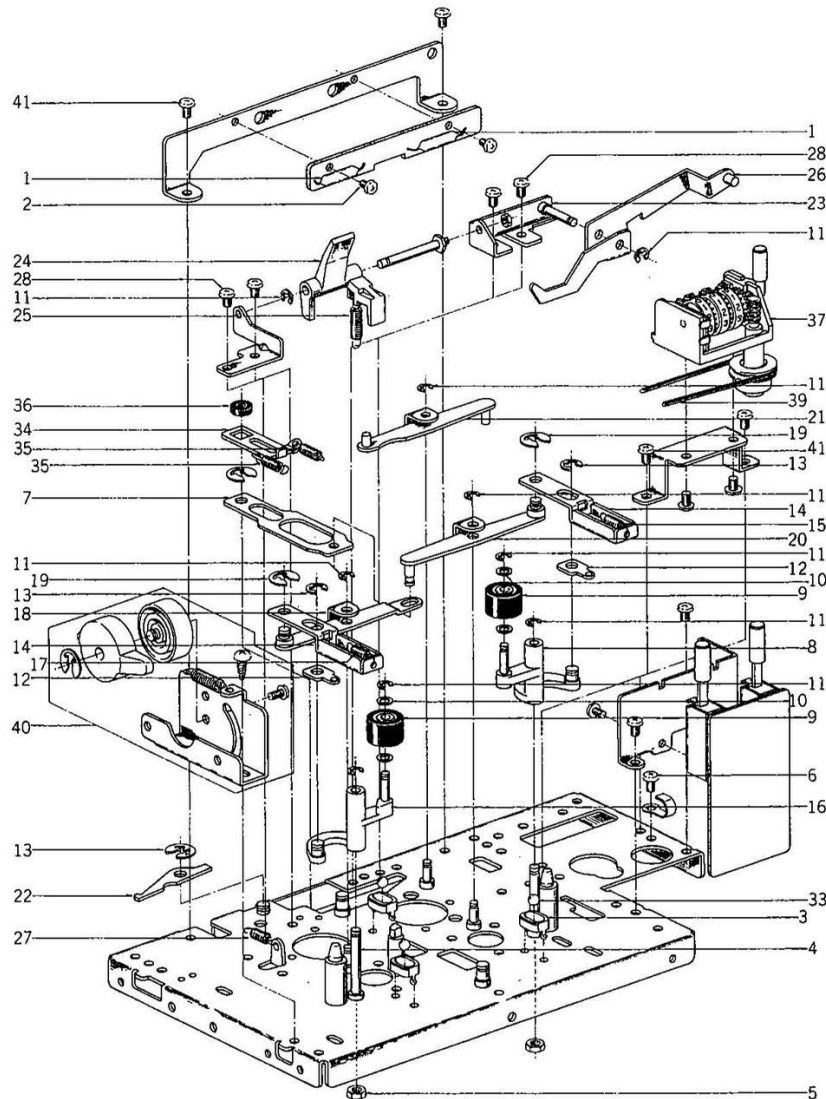

5) MECHA FRAME BLOCK (1)

Ref. No.	Parts No.	Description	Schematic No.	Ref. No.	Parts No.	Description	Schematic No.
HOUSING LAMP P.C BOARD BLOCK							
5-1	EL304025	Lamp (No. 2) 10V 110mA	28-2-66	5-21	ML302138	Play Arm Part GXC-570D-2	CI-1215
5-2	ZS417251	Screw, binding head 2.3x3		5-22	ML302208	Magnification Lever	CI-1227
MECHA FRAME BLOCK							
5-3	MS302191	Ball Guide	CI-1209	5-23	ML302139	Hold Bracket Part-G	CI-1223
5-4	MS302190	Pinch Roller Stud	CI-1208	GXC-570D-2			CI-1226
5-5	ZW273756	Nut M3, #1		5-24	TC302206	Cassette Push	CH-3007
5-6	ZS417216	Screw, pan head 3x4		5-25	ZG595506	Stop Spring	CI-1228
5-7	MZ302192	P Joint	CI-1210	5-26	ML302141	UP Lever Part GXC-570D-2	CS-2106
5-8	TC302134	PW Arm (R) Part GXC-570D-2	CI-1216	5-27	ZG394378	Return Spring	
5-9	MP612628	Pinch Roller Part CW	CW-0010	5-28	ZS200384	Screw, countersunk head 3x6	CI-1220
5-10	ZW282407	Push Washer (B)	CN-1056	5-29x	TC302142	Stand Part-G GXC-570D-2	
5-11	ZW270088	'E' Ring 1.9M	6-1-9	5-30x	ZS323728	Screw, binding head 3x5	
5-12	MZ302320	Clutch Plate	CI-1260	5-31x	ZS592378	Screw, pan head 2.6x3	
5-13	ZW270101	'E' Ring 3M	6-1-9	5-32x	ZS432843	Screw, pan head 2.6x4	
5-14	ML302199	P Slide	CI-1219	5-33	MV269965	Steel Ball D4	CI-1222
5-15	ZG302349	Pinch Roller Spring (R)	CI-1266	5-34	HZ302202	Head Clutch Plate	DF-5036
5-16	TC302135	PW Arm (L) Part GXC-570D-2	CI-1218	5-35	ZG445410	Slide Spring	CI-1268
5-17	ZG302644	Pinch Roller Spring (L)	CI-1269	5-36	MZ302351	Rubber Bush	9-1-57
5-18	ML302136	P Lever (B) Part GXC-570D-2	CI-1214	5-37	MC304094	Counter GXC-750D	9-1-60
5-19	ZW290283	'U' Ring 2.85M	6-1-1	5-38x	MC305453	Counter GXC-750D-BL	CI-1230
5-20	ML302137	P Lever (A) Part GXC-570D-2	CI-1211	5-39	MB302211	Counter Belt	
				5-40	TC302695	Oil Clutch (C) Comp.-G	
				GXC-570D-2			CI-2218
				5-41	ZS417216	Screw, pan head 3x4	

When ordering parts, please describe Parts Number, Description, and Model Number in detail.

6. ILLUSTRATION OF MECHA FRAME BLOCK (2)

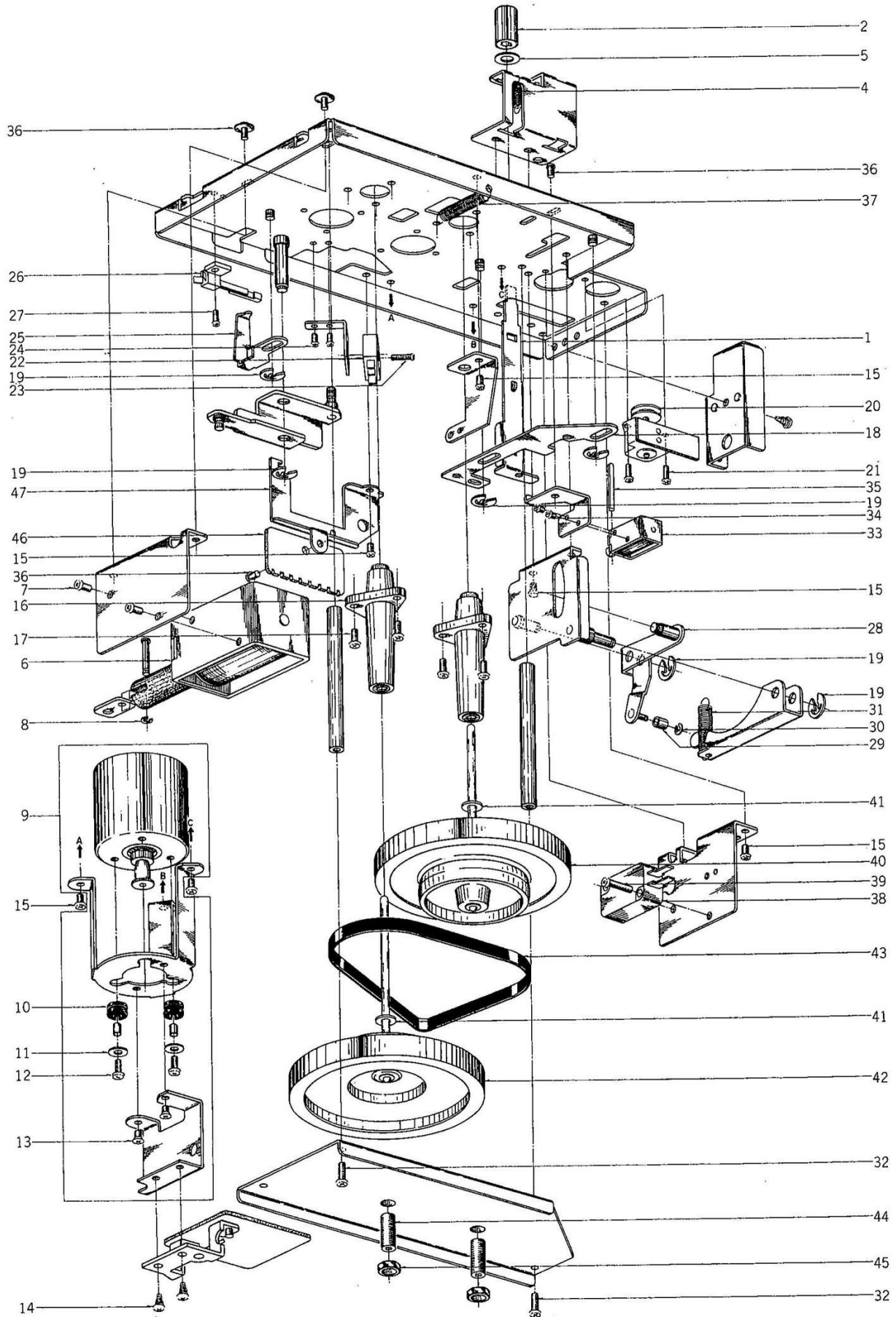

6) MECHA FRAME BLOCK (2)

Ref. No.	Parts No.	Description	
EJECT KEY BLOCK			
6-1	TC302329	Eject Key	CI-2208
6-2	SK303165	Push Button (A) GXC-709D	CM-6060
6-3x	SK305160	Push Button (C) GXC-709D-BL	CM-6060
6-4	ZG387178	Idler Tension Spring	CS-1106
6-5	ZW376402	Washer (Fiber) D5.1x10.3x1t	
PLUNGER BLOCK			
6-6	EP302690	Plunger Solenoid TDS-12E	44-1-95
6-7	ZS422076	Screw, pan head 3x5	
6-8	ZW270088	'E' Ring 1.9M	6-1-9
CAPSTAN MOTOR BLOCK			
6-9	BM303321	Capstan Motor Block Comp. GXC-750D	CI-1270
6-10	MB282778	Rubber Bush	CN-7003
6-11	ZW550697	Washer (SPC) D2.9x7.4x0.5t	
6-12	ZS608220	Screw, pan head 2.6x6	
6-13	ZS444330	Screw, countersunk head 3x4	
6-14	ZS325495	Tapping Screw #2, 3x6 (BR)	
MECHA FRAME BLOCK			
6-15	ZS417216	Screw, pan head 3x4	
6-16	MV302652	Metal Case Part GXC-570D-2	CI-1233
6-17	ZS379350	Screw, pan head 3x6	
6-18	ML302216	Play Slide	CI-1236
6-19	ZW290283	'U' Ring 2.85M	6-1-1
6-20	EZ304894	Rotary SW. Assy GXC-750D	CB-9805
6-21	ZS608106	Screw, pan head 2x6	
6-22	ES302940	Micro SW. SS-5GLC	25-1-46
6-23	ZS465298	Screw, pan head 2.3x10	
6-24	ZS460440	Screw, pan head 2x4	
6-25	ML302213	Detection Lever	CI-1232
6-26	ES302448	Leaf SW. BSW-81	25-10-28
6-27	ZS537085	Screw, binding head 2x5	
6-28	ML302653	Lock Lever (B) Part GXC-570D-2	CI-1244
6-29	MR302309	Roller (1)	CI-1247
6-30	ZW391397	'E' Ring 1.2M	6-1-9
6-31	ZG580768	Spoke Spring	TD-2077
6-32	ZS421806	Screw, pan head 3x8	
6-33	EP302445	Plunger Solenoid P-120F	44-1-90
6-34	ZS300626	Screw, pan head 2x2.5 (Camera Standard)	
6-35	MH302446	Spring Pin SPP 2x20	
6-36	ZS608321	Screw, pan head 3x6, W=8	
6-37	ZG317114	Tension Lever Spring	MR-39
6-38	ES305231	Micro SW. AH7450261	25-1-48
6-39	ZS419670	Screw, pan head 3x12	
6-40	BF302647	Flywheel (B) Part-G GXC-570D-2	CI-1255
6-41	ZW302401	Washer (Nylon)	CI-1267
6-42	BF302648	Flywheel (A) Part-G GXC-570D-2	CI-1253
6-43	MB302316	Capstan Belt	CI-1256
6-44	ZS302318	Holder Screw	CI-1258
6-45	ZW303680	Metal Nut	CI-1273
6-46	BA303612	Noise Filter P.C Board Comp. GXC-750D	CB-9811
6-47	ML302402	Noise Filter Bracket	CI-2210

10. LIST OF INTERCHANGEABLE SEMICONDUCTORS

If, while servicing, the original parts cannot be obtained, the interchangeable parts listed below can be substituted.

Original Parts			Interchangeable Parts	
Description	Parts No.	Utilizing P.C Board	Description	Parts No.
2SA733 (P) (Q)	ET554657	CB-5203	2SA564 (Q) (R)	ET538154
2A906 (H)	ET304180	CB-5201A		
2SB525 (E1)	ET302540	CB-5207		
2SB605 (K) (L)	ET666415	CB-5202 CB-5203		
2SC458LG (D)	ET352146	CB-5201A	2SC693U (F) (G) 2SC1312S (G) (H)	ET429647 ET603257
2SC536 (E)	ET361923	CB-5202	2SC945L (K) (P) (Q) (R)	ET635218
2SC711 (G)	ET399870	CB-5202	2SC536 (G) (H) 2SC1647 (S) (E) (U)	ET403391 ET601312
2SC711 (G) (H)	ET563905	CB-5203		
2SC711 (G) (F)	ET398777	CB-5202		
2SC711 (F) (G) (H)	ET621268	CB-5202		
2SC711 (H)	ET429748	CB-5202	2SC1344 (E) 2SC1647 (E) (U)	ET539853 ET619762
2SC945L (P)	ET638504	CB-5207	2SC711 (E) (F) (G) (H)	ET619727
2SC945L (K) (P)	ET635220	CB-5202	2SC1641 (R) (S)	ET621224
2SC945L (Q) (P)	ET639437	CB-5201A	2SC536 (F) (G) (H)	ET632215
2SC1312R (H)	ET539864	CB-5207 CB-5201A	2SC458LG (C) (D)	ET391768
2SC1312S (H)	ET242684	CB-5202	2SC458LG (C) (D)	ET391768
2SC2002 (K)	ET304181	CB-5201A		
2SD355 (E1)	ET302538	CB-5207		
2SD355 (D2) (E1)	ET302300	CB-5202		
2SD439 (F)	ET304167	CB-5203		
2SD571 (L) (M)	ET655356	CB-5201A	2SD313 (E) (F)	ET452531
2SK68A (L) (M)	ET669633	CB-5201A	2SK117 (G) (R)	ET303697
CR-713B	EI301463	CB-5201A		
TA-7139P	EI302623	CB-5201A		
TA-7140P	EI304190	CB-5201A		
TC-4011P	EI404657	CB-5202		
MB400/7400	EI304165	CB-5202	SN7400N	EI633982
μ PC1023H	EI669666	CB-5207		
μ A78M05CKC	EI304173	CB-5203		
μ A7824CKC	EI304174	CB-5203		
1S2473 1S2473VE	ED624903 ED560913	CB-5202 CB-5201A CB-5202 CB-5203 CB-5207	1S1588 WG599	ED557447 ED514721
1N34A	ED219464	CB-5201A CB-5202 CB-5203	1S188AM 1S188FM-1 1N60	ED562386 ED562397 ED428264

Original Parts			Interchangeable Parts	
Description	Parts No.	Utilizing P.C Board	Description	Parts No.
RD-3E (B)	ED304656	CB-5201A		
RD-13E (B) (C)	ED304247	CB-5203		
RD-16E (B) (C)	ED304246	CB-5202		
10D1	ED224526	CB-5203	GP08B	ED302640
WZ-210	ED557111	CB-5201A		
SIQB20 0.6A 200 (RED)	ED249581	CB-5203	SIQB10 0.6A 100V (BLK)	ED284095
SIRBA20 200V (RED)	ED304658	CB-5203		
GL-3PG1	ED283138	CB-5201B		