

SERVICE MANUAL

MODEL No. **AD-WX808**

■ STEREO CASSETTE DECK

■ TYPE. HB,UB,EB,KB,ZB

■ BASIC MECHANISM : X-3

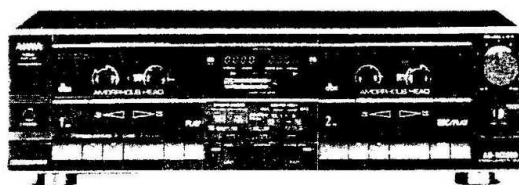

SPECIFICATIONS

Type	Stereo cassette tape deck	
Track format	4 tracks, 2 channels	
Power supply	AD-WX808E, Z AC 220 V, 50/60 Hz AD-WX808K AC 240 V, 50/60 Hz AD-WX808U AC 120 V, 60 Hz AD-WX808H AC 120 V/220 V/240 V switchable, 50/60 Hz	
Power consumption	AD-WX808E, K, Z 36 W AD-WX808H, U 30 W	
Frequency response	METAL tape:	20 - 18,000 Hz
	CrO ₂ tape:	20 - 17,000 Hz
	NORMAL tape:	20 - 16,000 Hz
Signal-to-noise ratio	92 dB (CrO ₂ tape dbx NR ON) 73 dB (METAL tape DOLBY C NR ON)	

Wow and flutter	Deck [1]	0.1% (According to DIN 45500) 0.055% (WRMS)
	Deck [2]	0.1% (According to DIN 45500) 0.055% (WRMS)
Tape speed	4.8 cm/sec. (1-7/8 ips), 9.5 cm/sec (Double speed)	
Recording system	AC bias (frequency 100 kHz)	
Erase system	AC erase	
Motor	DC Servomotor × 2	
Heads	Record/playback head × 1 (AMORPHOUS HEAD) Playback head × 1 (AMORPHOUS HEAD) Erase head × 1	
Inputs	LINE IN maximum input sensitivity: 50 mV (over 50 kΩ)	
Outputs	LINE OUT standard output level: 400 mV (0 VU); suitable load impedance: over 47 kΩ. 430(W) × 126.5(H) × 318.5(D)mm	
Dimensions		
Weight	5.5 kg	

• HX professional originated by BANG&OLUFSEN.

- Design and specifications are subject to change without notice.
- Noise reduction system manufactured under license from Dolby Laboratories Licensing Corporation.
- Dolby and the  symbol are trademarks of Dolby Laboratories Licensing Corporation.

REF.NO. PART NO. ORDER DESCRIPTION

--- IC ---

87-001-144-010 IC,AN6292NK
 87-020-180-010 IC,BA6146
 87-001-143-010 IC,CX20187
 87-020-454-010 IC,DM6851

 82-202-621-010 IC,HD38702A39
 87-020-140-010 IC,L78M12
 87-020-261-010 IC,LA6358S
 82-224-614-010 IC,LC6520H-3386

 87-020-533-010 IC,M4069UBP
 87-027-895-010 IC,M5218L
 87-020-680-010 IC,NJM2068S
 87-020-758-010 IC,NJM2068SD

 87-001-133-010 IC,NJU4052BP
 87-020-908-010 IC,NJU4066BD

--- TRANSISTOR ---

89-503-735-010 FET,2SK373GR
 87-026-219-010 TRANSISTOR,DTA144ES
 87-026-292-010 TRANSISTOR,DTA144WS
 87-026-218-010 TRANSISTOR,DTC144ES

 89-109-521-010 TRANSISTOR,2SA952K
 89-110-155-010 TRANSISTOR,2SA1015GR
 89-313-834-010 TRANSISTOR,2SC1383(S)
 89-318-155-010 TRANSISTOR,2SC1815GR

 89-320-011-010 TRANSISTOR,2SC2001K
 89-331-138-010 TRANSISTOR,2SC3113B
 89-309-456-010 TRANSISTOR,2SC945LP
 89-411-110-010 TRANSISTOR,2SD1111

 89-413-023-010 TRANSISTOR,2SD1302S
 89-414-065-010 TRANSISTOR,2SD1406GR

--- MAIN CIRCUIT BOARD SECTION ---

PCB-A * MAIN CIRCUIT BOARD
 C1 *82-186-685-010 CAP,ELECT 3300-35
 C3 *87-010-235-010 CAP,ELECT 470-16
 C5 *87-010-237-010 CAP,ELECT 1000-16 SME

 C6 *87-010-623-010 CAP,ELECT 470-63
 C7 *87-010-623-010 CAP,ELECT 470-63
 C8 *87-010-374-010 CAP,ELECT 47-10
 C9 *87-010-565-010 CAP,ELECT 470-12

 C10 *87-010-248-010 CAP,ELECT 220-10 SME
 C11 *87-010-404-010 CAP,ELECT 4.7-50 SME
 C12 *87-010-260-010 CAP,ELECT 47-25 SME
 C22 *87-010-401-010 CAP,ELECT 1-50 SME

 C23 *87-010-248-010 CAP,ELECT 220-10 SME
 C101 *87-018-121-010 CAP,CERA-SOL SS 150P
 C102 *87-018-121-010 CAP,CERA-SOL SS 150P
 C103 *87-018-106-010 CAP,CERA-SOL SS 15P

 C104 *87-018-106-010 CAP,CERA-SOL SS 15P
 C107 *87-010-134-010 CAP,ELECT BP 4.7-35
 C108 *87-010-134-010 CAP,ELECT BP 4.7-35
 C111 *87-018-205-010 CAP,CERA-SOL SS 0.022

 C112 *87-010-101-010 CAP,ELECT 220-16 SME
 C113 *87-018-119-010 CAP,CERA-SOL SS 100P
 C114 *87-018-119-010 CAP,CERA-SOL SS 100P
 C201 *87-018-121-010 CAP,CERA-SOL SS 150P

 C202 *87-018-121-010 CAP,CERA-SOL SS 150P
 C203 *87-018-106-010 CAP,CERA-SOL SS 15P
 C204 *87-018-106-010 CAP,CERA-SOL SS 15P
 C207 *87-010-134-010 CAP,ELECT BP 4.7-35

 C208 *87-010-134-010 CAP,ELECT BP 4.7-35
 C211 *87-018-205-010 CAP,CERA-SOL SS 0.022

REF.NO. PART NO. ORDER DESCRIPTION

C221 *87-018-119-010 CAP,CERA-SOL SS 100P
 C222 *87-018-119-010 CAP,CERA-SOL SS 100P
 C223 *87-018-121-010 CAP,CERA-SOL SS 150P
 C224 *87-018-121-010 CAP,CERA-SOL SS 150P

 C251 *87-018-133-010 CAP,CERA-SOL SS 4700P
 C252 *87-018-097-010 CAP,CERA-SOL SS 2.2P
 C253 *87-018-133-010 CAP,CERA-SOL SS 4700P
 C254 *87-018-205-010 CAP,CERA-SOL SS 0.022

 C255 *88-337-790-010 CAP,ELECT 0.68-50
 C256 *87-010-112-010 CAP,ELECT 100-16
 C301 *87-010-402-010 CAP,ELECT 2.2-50 SME
 C302 *87-010-402-010 CAP,ELECT 2.2-50 SME

 C319 *87-018-131-010 CAP,CERA-SOL SS 1000P
 C320 *87-018-131-010 CAP,CERA-SOL SS 1000P
 C413 *87-010-385-010 CAP,ELECT 220-25
 C421 *87-010-260-010 CAP,ELECT 47-25 SME

 C422 *87-010-382-010 CAP,ELECT 22-25 SME
 C425 *87-018-133-010 CAP,CERA-SOL SS 4700P
 C428 *87-014-079-010 CAP,PP 8200P
 C429 *87-018-131-010 CAP,CERA-SOL SS 1000P

 C430 *87-010-378-010 CAP,ELECT 10-16
 C431 *87-018-121-010 CAP,CERA-SOL SS 150P
 C432 *87-018-121-010 CAP,CERA-SOL SS 150P
 C451 *87-018-131-010 CAP,CERA-SOL SS 1000P

 C452 *87-018-131-010 CAP,CERA-SOL SS 1000P
 C455 *87-018-131-010 CAP,CERA-SOL SS 1000P
 C456 *87-018-131-010 CAP,CERA-SOL SS 1000P
 C457 *87-018-131-010 CAP,CERA-SOL SS 1000P

 C458 *87-018-131-010 CAP,CERA-SOL SS 1000P
 C461 *87-018-123-010 CAP,CERA-SOL SS 220P
 C462 *87-018-123-010 CAP,CERA-SOL SS 220P
 C465 *87-010-260-010 CAP,ELECT 47-25 SME

 C466 *87-010-565-010 CAP,ELECT 470-12
 C505 *87-010-378-010 CAP,ELECT 10-16
 C506 *87-010-378-010 CAP,ELECT 10-16
 C507 *87-010-378-010 CAP,ELECT 10-16

 C508 *87-010-378-010 CAP,ELECT 10-16
 C509 *87-010-624-010 CAP,ELECT 220-16 SXJ
 C510 *87-010-624-010 CAP,ELECT 220-16 SXJ
 C515 *87-010-400-010 CAP,ELECT 0.47-50 SME

 C516 *87-010-400-010 CAP,ELECT 0.47-50 SME
 C521 *87-010-545-010 CAP,ELECT 0.22-50 SME
 C522 *87-010-545-010 CAP,ELECT 0.22-50 SME
 C531 *87-010-378-010 CAP,ELECT 10-16

 C532 *87-010-378-010 CAP,ELECT 10-16
 C601 *87-010-379-010 CAP,ELECT 22-16 SME
 C602 *87-010-379-010 CAP,ELECT 22-16 SME
 C605 *87-014-044-010 CAP,PP 300P

 C606 *87-014-044-010 CAP,PP 300P
 C607 *87-010-621-010 CAP,ELECT 1.5-50 MA
 C608 *87-010-621-010 CAP,ELECT 1.5-50 MA
 C609 *87-018-197-010 CAP,CERA-SOL SS 1800P

 C610 *87-018-197-010 CAP,CERA-SOL SS 1800P
 C611 *87-018-197-010 CAP,CERA-SOL SS 1800P
 C612 *87-018-197-010 CAP,CERA-SOL SS 1800P
 C613 *87-010-403-010 CAP,ELECT 3.3-50 SME

 C614 *87-010-403-010 CAP,ELECT 3.3-50 SME
 C615 *87-010-137-010 CAP,ELECT BP 22-16
 C616 *87-010-137-010 CAP,ELECT BP 22-16
 C629 *87-014-045-010 CAP,PP 330P

 C630 *87-014-045-010 CAP,PP 330P
 C641 *87-010-624-010 CAP,ELECT 220-16 SXJ
 C643 *87-010-624-010 CAP,ELECT 220-16 SXJ
 C645 *87-010-620-010 CAP,TANTALUM 22-16 J

REF. NO.	PART NO.	ORDER	DESCRIPTION
C646	*87-010-620-010		CAP,TANTALUM 22-16 J
C700	*87-018-134-010		CAP,CERA-SOL SS 0.01
C701	*87-015-241-010		CAP,ELECT LL 1-50
C702	*87-015-241-010		CAP,ELECT LL 1-50
C801	*87-018-118-010		CAP,CERA-SOL SS 82P
C802	*87-018-205-010		CAP,CERA-SOL SS 0.022
C851	*87-010-565-010		CAP,ELECT 470-12 SME
C852	*87-010-565-010		CAP,ELECT 470-12 SME
C853	*87-010-565-010		CAP,ELECT 470-12 SME
C854	*87-010-565-010		CAP,ELECT 470-12 SME
C861	*87-010-379-010		CAP,ELECT 22-16 SME
C882	*87-010-402-010		CAP,ELECT 2.2-50 SME
C883	*87-010-379-010		CAP,ELECT 22-16 SME
C884	*87-010-402-010		CAP,ELECT 2.2-50 SME
C900	*87-018-134-010		CAP,CERA-SOL SS 0.01
C901	*87-010-401-010		CAP,ELECT 1-50 SME
C902	*87-010-401-010		CAP,ELECT 1-50 SME
C951	*87-010-404-010		CAP,ELECT 4.7-50 SME
C952	*87-010-404-010		CAP,ELECT 4.7-50 SME
C953	*87-010-378-010		CAP,ELECT 10-16
C954	*87-010-378-010		CAP,ELECT 10-16
C955	*87-010-380-010		CAP,ELECT 47-16 SME
C956	*87-010-380-010		CAP,ELECT 47-16 SME
C957	*87-010-385-010		CAP,ELECT 220-25
C959	*87-015-244-010		CAP,ELECT LL 4.7-50
C960	*87-015-244-010		CAP,ELECT LL 4.7-50
C961	*87-018-134-010		CAP,CERA-SOL SS 0.01
C1404	*87-010-404-010		CAP,ELECT 4.7-50 SME
C1451	*87-010-402-010		CAP,ELECT 2.2-50 SME
C1452	*87-010-402-010		CAP,ELECT 2.2-50 SME
D1	82-001-187-010		DIODE S5277B,LC6
D2	82-001-187-010		DIODE S5277B,LC6
D3	82-001-187-010		DIODE S5277B,LC6
D4	82-001-187-010		DIODE S5277B,LC6
D5	82-001-187-010		DIODE S5277B,LC6
D6	87-020-123-010		DIODE DS446
D7	87-027-393-010		DIODE,ZENER HZ-4C2
D8	87-020-752-010		DIODE 1SS270
D9	87-027-286-010		DIODE,ZENER HZ-5C1
D10	87-027-561-010		DIODE,ZENER H30-2L
D11	87-027-347-010		DIODE,ZENER HZ-18-2L T2
D251	87-027-286-010		DIODE,ZENER HZ-5C1
D252	87-020-752-010		DIODE 1SS270
D401	87-020-752-010		DIODE 1SS270
D402	87-020-752-010		DIODE 1SS270
D404	87-020-123-010		DIODE DS446
D421	87-020-752-010		DIODE 1SS270
D451	87-020-752-010		DIODE 1SS270
D452	87-020-752-010		DIODE 1SS270
D453	87-020-752-010		DIODE 1SS270
D454	87-020-752-010		DIODE 1SS270
D457	87-027-416-010		DIODE,ZENER HZ3C2
D801	87-020-752-010		DIODE 1SS270
D802	87-020-752-010		DIODE 1SS270
D803	87-020-752-010		DIODE 1SS270
D804	87-020-752-010		DIODE 1SS270
D805	87-020-752-010		DIODE 1SS270
D806	87-020-752-010		DIODE 1SS270
D807	87-020-752-010		DIODE 1SS270
D808	87-020-752-010		DIODE 1SS270
D809	87-020-752-010		DIODE 1SS270
D810	87-020-752-010		DIODE 1SS270
D811	87-020-752-010		DIODE 1SS270
D812	87-020-752-010		DIODE 1SS270

REF. NO.	PART NO.	ORDER	DESCRIPTION
D813	87-020-752-010		DIODE 1SS270
D814	87-020-752-010		DIODE 1SS270
D851	87-020-123-010		DIODE DS446
D852	87-020-123-010		DIODE DS446
D853	87-020-123-010		DIODE DS446
D854	87-020-123-010		DIODE DS446
D901	87-020-752-010		DIODE 1SS270
D902	87-020-752-010		DIODE 1SS270
D903	87-020-752-010		DIODE 1SS270
D904	87-020-752-010		DIODE 1SS270
D951	87-020-752-010		DIODE 1SS270
D952	87-020-752-010		DIODE 1SS270
D953	87-020-752-010		DIODE 1SS270
D1401	87-020-752-010		DIODE 1SS270
D1402	87-020-752-010		DIODE 1SS270
Δ FR1	87-029-090-010		RES,FUSIBLE 22-1/4W
ICP1	*83-203-688-010		PROTECTOR ICP-N25
ICP2	*87-001-211-010		PROTECTOR ICP-N50
J701	87-049-420-010		PIN JACK 4P-14(LINE IN)
J901	87-049-420-010		PIN JACK 4P-14(LINE OUT)
L251	*81-760-621-010		COIL 130UH
L301	*87-003-128-010		INDUCTOR 5.6MMH
L302	*87-003-128-010		INDUCTOR 5.6MMH
L303	*87-003-131-010		COIL CHOKO 10MMH
L304	*87-003-131-010		COIL CHOKO 10MMH
L305	*82-196-603-010		COIL TRAP 100K
L306	*82-196-603-010		COIL TRAP 100K
L401	*82-203-623-010		COIL OSC BIAS 100K
L451	*82-203-624-010		COIL HX 100K AM W/C
L452	*82-203-624-010		COIL HX 100K AM W/C
L501	*82-221-697-010		FILTER SQ,CX
L502	*82-221-697-010		FILTER SQ,CX
L503	*82-224-612-010		FILTER DOLBY 100K
L504	*82-224-612-010		FILTER DOLBY 100K
L801	*82-202-624-010		COIL OSC LC6520H
R603	*87-025-442-010		RES,MF 6.2K 1/8W F
R604	*87-025-442-010		RES,MF 6.2K 1/8W F
R605	*87-025-443-010		RES,MF 24K 1/8W F
R606	*87-025-443-010		RES,MF 24K 1/8W F
R615	*87-025-428-010		RES,MF 33K 1/8W
R616	*87-025-428-010		RES,MF 33K 1/8W
R617	*87-025-444-010		RES,MF 91K 1/8W F
R618	*87-025-444-010		RES,MF 91K 1/8W F
R619	*87-025-423-010		RES,MF 4.7K 1/8W
R620	*87-025-423-010		RES,MF 4.7K 1/8W
R621	*87-025-428-010		RES,MF 33K 1/8W
R622	*87-025-428-010		RES,MF 33K 1/8W
R623	*87-025-376-010		RES,MF 6.8K 1/8W
R624	*87-025-376-010		RES,MF 6.8K 1/8W
R625	*87-025-367-010		RES,MF 1K 1/8W
R626	*87-025-367-010		RES,MF 1K 1/8W
R627	*87-025-424-010		RES,MF 10K 1/8W
R628	*87-025-424-010		RES,MF 10K 1/8W
R629	*87-025-367-010		RES,MF 1K 1/8W
SFR101	*87-021-738-010		SFR 1K
SFR102	*87-021-738-010		SFR 1K
SFR103	*87-021-739-010		SFR 2.2K
SFR104	*87-021-739-010		SFR 2.2K
SFR201	*87-021-738-010		SFR 1K
SFR202	*87-021-738-010		SFR 1K
SFR203	*87-021-739-010		SFR 2.2K
SFR204	*87-021-739-010		SFR 2.2K
SFR301	*87-021-741-010		SFR 4.7K
SFR302	*87-021-741-010		SFR 4.7K

REF. NO.	PART NO.	ORDER	DESCRIPTION
SFR451	*87-027-746-010		SFR 100K
SFR452	*87-027-746-010		SFR 100K
SFR601	*87-021-741-010		SFR 4.7K
SFR1451	*87-021-747-010		SFR 220K
SFR1452	*87-021-747-010		SFR 220K
--- KEY CIRCUIT BOARD SECTION ---			
PCB-B	*		KEY CIRCUIT BOARD
D1001	87-020-752-010		DIODE 1SS270
D1002	87-020-752-010		DIODE 1SS270
D1003	87-027-556-010		DIODE,ZENER HZ11B3
D1505	87-020-752-010		DIODE 1SS270
D1506	87-020-752-010		DIODE 1SS270
D1507	87-020-752-010		DIODE 1SS270
D1508	87-020-752-010		DIODE 1SS270
D1509	87-020-752-010		DIODE 1SS270
D1510	87-020-752-010		DIODE 1SS270
D1511	87-020-752-010		DIODE 1SS270
D1512	87-020-752-010		DIODE 1SS270
D1513	87-020-752-010		DIODE 1SS270
D1514	87-020-752-010		DIODE 1SS270
D1515	87-020-752-010		DIODE 1SS270
D1516	87-020-752-010		DIODE 1SS270
D1517	87-020-752-010		DIODE 1SS270
D1518	87-020-752-010		DIODE 1SS270
D1519	87-020-752-010		DIODE 1SS270
D1573	*87-001-137-010		LED,SLP981CS0 R(REC MUTE)
D1574	*87-001-138-010		LED,SLP481CS0 Y(D1 PAUSE)
D1575	*87-001-138-010		LED,SLP481CS0 Y(D2 PAUSE)
D1576	*87-001-137-010		LED,SLP981CS0 R(SYNC.DUB.HI)
D1577	*87-001-137-010		LED,SLP981CS0 R(SYNC.DUB.NOR)
SW1001	82-221-614-010		SLIDE SW(DOLBY B-C/OBX)
SW1505	87-031-893-010		TACT SW(REC D2)
SW1506	87-031-893-010		TACT SW(REC MUTE)
SW1507	87-031-893-010		TACT SW(SYN.DUB.HI)
SW1508	87-031-893-010		TACT SW(SYN.DUB.NOR)
SW1509	87-031-893-010		TACT SW(STOP D1)
W1510	87-031-893-010		TACT SW(PAUSE D1)
W1511	87-031-893-010		TACT SW(MS/▶▶D1)
SW1512	87-031-893-010		TACT SW(◀◀/MS D1)
SW1513	87-031-893-010		TACT SW(STOP D2)
SW1514	87-031-893-010		TACT SW(PAUSE D2)
SW1515	87-031-893-010		TACT SW(MS/▶▶D2)
SW1516	87-031-893-010		TACT SW(◀◀/MS D2)
SW1517	87-036-032-010		RES,SLD SW(TIMER)
SW1518	87-036-053-010		SLIDE SW(REV.MODE)
SW1519	87-036-033-010		SLIDE SW(BLANK SKIP)
--- FL CIRCUIT BOARD SECTION ---			
PCB-C	*		FL CIRCUIT BOARD
C1401	*87-018-119-010		CAP,CERA-SOL SS 100P
C1402	*87-010-421-010		CAP,ELECT 4.7-50 SRE
C1403	*87-010-421-010		CAP,ELECT 4.7-50 SRE
C1406	*87-010-075-010		CAP,ELECT 10-16
C1407	*87-010-075-010		CAP,ELECT 10-16
FL1	*82-221-700-010		FL CP5319 AGR(DISPLAY)
SW1401	87-031-893-010		TACT SW(COUNT.RESET D1)
SW1402	87-031-893-010		TACT SW(COUNT.RESET D2)
--- POWER CIRCUIT BOARD SECTION ---			
Δ PCB-D	*		POWER CIRCUIT BOARD
C15	*87-019-112-010		SPARK KILLER 0.01 E
C751	*87-010-544-010		CAP,ELECT 0.1-50
C752	*87-010-544-010		CAP,ELECT 0.1-50

REF. NO.	PART NO.	ORDER	DESCRIPTION
C753	*87-010-101-010		CAP,ELECT 220-16 SME
C754	*87-010-101-010		CAP,ELECT 220-16 SME
C755	*87-010-385-010		CAP,ELECT 220-25
J751	87-049-827-010		JACK HLJ-0521-010(PHONES)
Δ S1	82-224-617-010		PUSH SW(POWER)
--- SW-1 CIRCUIT BOARD SECTION ---			
PCB-E	*		SW-1 CIRCUIT BOARD
D1501	87-020-752-010		DIODE 1SS270
D1502	87-020-752-010		DIODE 1SS270
D1561	*87-001-159-010		LED,SLV31MC 3F GR(D1 PLAY)
D1562	*87-001-159-010		LED,SLV31MC 3F GR(D1 PLAY)
D1563	*87-001-159-010		LED,SLV31MC 3F GR(D1 PLAY)
D1564	*87-001-159-010		LED,SLV31MC 3F GR(D1 PLAY)
SW1501	87-031-893-010		TACT SW(FWD PLAY D1)
SW1502	87-031-893-010		TACT SW(REV PLAY D1)
--- SW-2 CIRCUIT BOARD SECTION ---			
PCB-F	*		SW-2 CIRCUIT BOARD
D1503	87-020-752-010		DIODE 1SS270
D1504	87-020-752-010		DIODE 1SS270
D1565	*87-001-160-010		LED,SLV31MC 3F RED(D2 PLAY)
D1566	*87-001-160-010		LED,SLV31MC 3F RED(D2 PLAY)
D1567	*87-001-160-010		LED,SLV31MC 3F RED(D2 PLAY)
D1568	*87-001-160-010		LED,SLV31MC 3F RED(D2 PLAY)
D1569	*87-001-159-010		LED,SLV31MC 3F GR(D2 REC)
D1570	*87-001-159-010		LED,SLV31MC 3F GR(D2 REC)
D1571	*87-001-159-010		LED,SLV31MC 3F GR(D2 REC)
D1572	*87-001-159-010		LED,SLV31MC 3F GR(D2 REC)
SW1503	87-031-893-010		TACT SW(FWD PLAY D2)
SW1504	87-031-893-010		TACT SW(REV PLAY D2)
--- VL CIRCUIT BOARD SECTION ---			
PCB-G	*		VL CIRCUIT BOARD
C721	*87-015-241-010		CAP,ELECT LL 1-50
C722	*87-015-241-010		CAP,ELECT LL 1-50
VR401	82-224-618-010		VOLUME 250KB,PH16 (BIAS FINE,NOR/CRO2)
VR721	82-224-613-010		VOLUME 10KA(RK16)(REC LEVEL)
--- TR CIRCUIT BOARD SECTION ---			
PCB-H	*		TR CIRCUIT BOARD
--- MECHANISM-1 CIRCUIT BOARD SECTION ---			
PCB-I	*		MECHANISM-1 CIRCUIT BOARD
S1108	87-036-040-010		PUSH SW(CO,D1)
S1109	87-036-039-010		PUSH SW(CST,D1)
S1110	87-036-039-010		PUSH SW(DIR,D1)
SFR110	87-021-966-010		SFR 4.7K (D1)
SFR111	87-021-966-010		SFR 4.7K (D1)
SOL110	86-535-611-010		SOLENOID X-3 PL(D1)
SOL111	86-535-612-010		SOLENOID X-3 FR(D1)
--- MECHANISM-2 CIRCUIT BOARD SECTION ---			
PCB-J	*		MECHANISM-2 CIRCUIT BOARD
S1101	87-036-039-010		PUSH SW(MT,D2)
S1102	87-036-040-010		PUSH SW(CO,D2)
S1103	87-036-039-010		PUSH SW(CST,D2)
S1104	87-036-039-010		PUSH SW(DIR,D2)
S1105	87-036-039-010		PUSH SW(RE-8,D2)
S1106	87-036-039-010		PUSH SW(RE-4,D2)
SFR110	87-021-966-010		SFR 4.7K(D2)
SFR111	87-021-966-010		SFR 4.7K(D2)
SFR110</			

SCHMATIC DIAGRAM-1

REF.NO. PART NO. ORDER DESCRIPTION

SOL110 86-535-612-010 SOLENOID X-3 FR(D2)

--- SENSOR CIRCUIT BOARD SECTION ---

PCB-K * SENSOR CIRCUIT BOARD
CP1101 87-020-755-010 PHOTO SENSOR SPI-900

--- MISCELLANEOUS ---

△ *87-034-732-010 AC CORD H ASSY(H)
△ *87-034-731-010 AC CORD (UL) ASSY(U)
△ *87-034-736-010 AC CORD E ASSY(E)
△ *87-034-734-010 AC CORD K ASSY(K)

△ *87-085-184-010 AC CORD BUSHING(H)
△ *87-085-189-010 AC CORD BUSHING U(U)
△ *87-085-185-010 AC CORD BUSHING E(E)
D1201 *87-020-109-010 LED SLF-201C(D1)

D1202 *87-020-109-010 LED SLF-201C(D2)
M1001 87-045-235-010 MOTOR MMA6B2LW(D1)
M1002 87-045-235-010 MOTOR MMA6B2LW(D2)
PH 87-046-296-010 HEAD PH(D1)

REF.NO. PART NO. ORDER DESCRIPTION

△ PT1 82-221-621-010 POWER TRANSFORMER H(H)
△ PT1 82-221-622-010 POWER TRANSFORMER UC(U,C)
△ PT1 82-221-623-010 POWER TRANSFORMER EZ(E,Z)
△ PT1 82-221-625-010 POWER TRANSFORMER KG(K,G)

RPEH 87-046-289-010 HEAD RPEH HADKH 5503A(D2)
△ SW2 87-031-586-010 ROTARY SW(H)(AC VOLTAGE)

Combination circuit board A 82-221-601-010

PCB-A 82-221-602-010

PCB-B 82-221-603-010

PCB-C 82-221-604-010

PCB-D 82-221-605-010

PCB-E 82-221-606-010

PCB-F 82-221-607-010

PCB-G 82-221-610-010

PCB-H 82-221-609-010

Combination circuit board B 86-535-601-210

PCB-I,J 86-535-602-210

PCB-K,L 86-535-603-210

IC BLOCK DIAGRAM

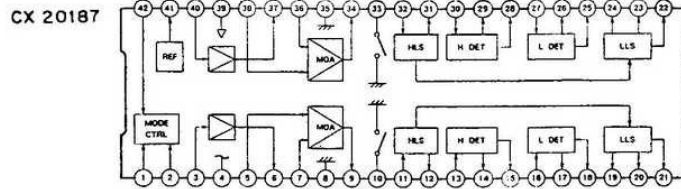
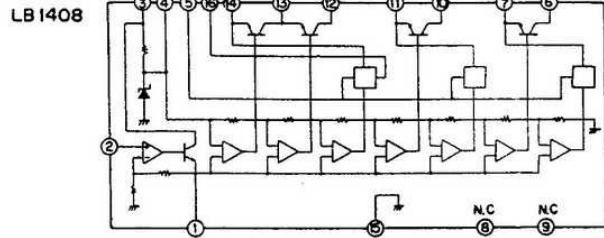

NJU4052BP

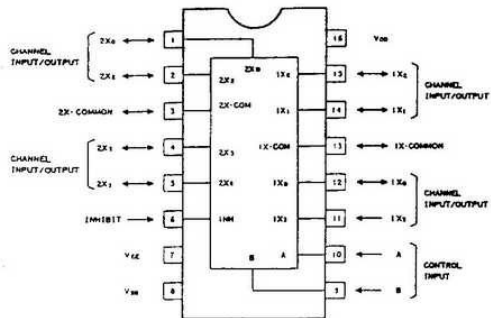

TRUTH TABLE

INHIBIT INPUT	CONTROL INPUT	CHANNEL INPUT/OUTPUT SWITCH OF COMMON TERMINAL					
INHIBIT	B	A	Xa	X1	X2	X3	
L	L	L	ON	OFF	OFF	OFF	
L	L	H	OFF	ON	OFF	OFF	
L	H	L	OFF	OFF	ON	OFF	
L	H	H	OFF	OFF	OFF	ON	
H	X	X	OFF	OFF	OFF	OFF	

Note 1 X: "H" or "L"

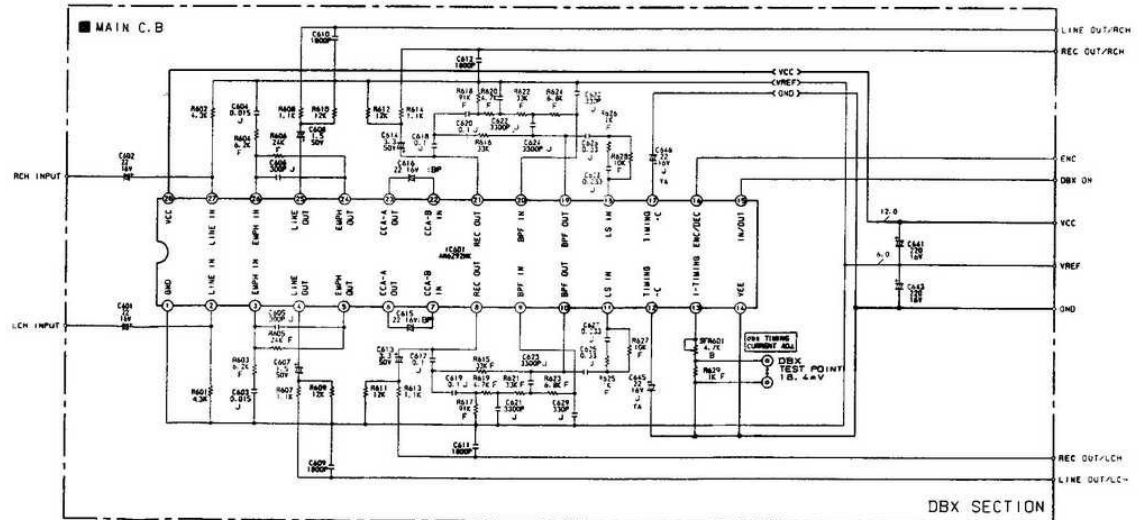
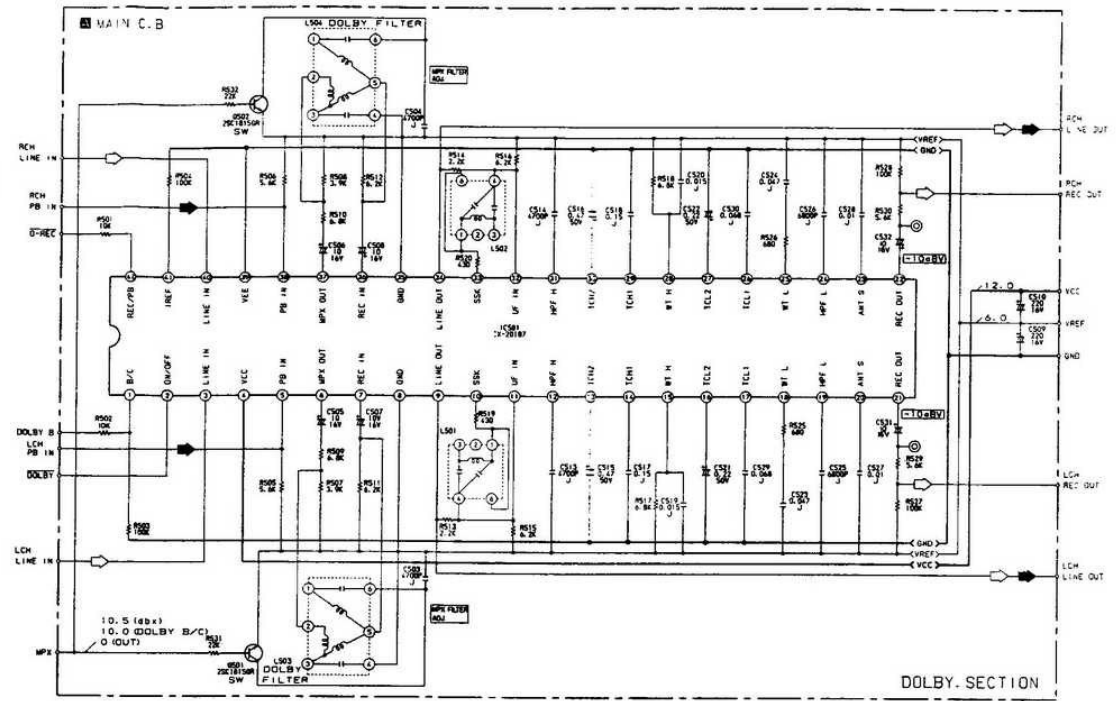

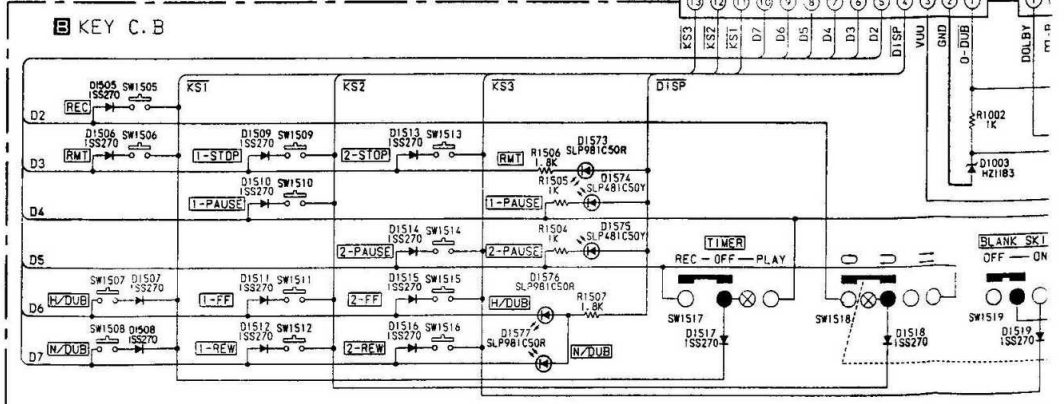
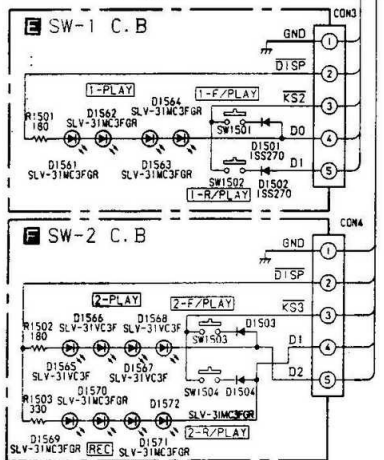
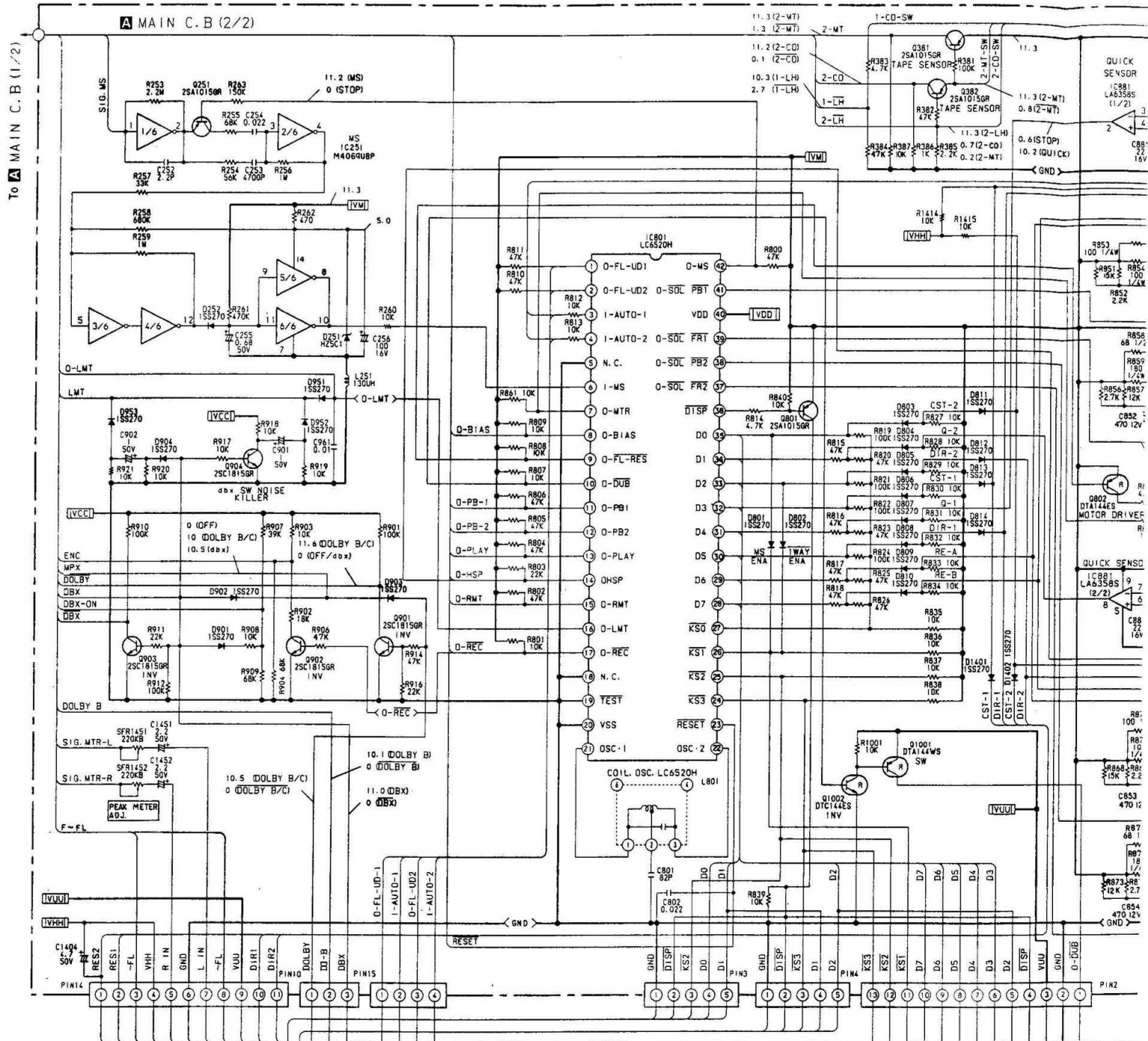

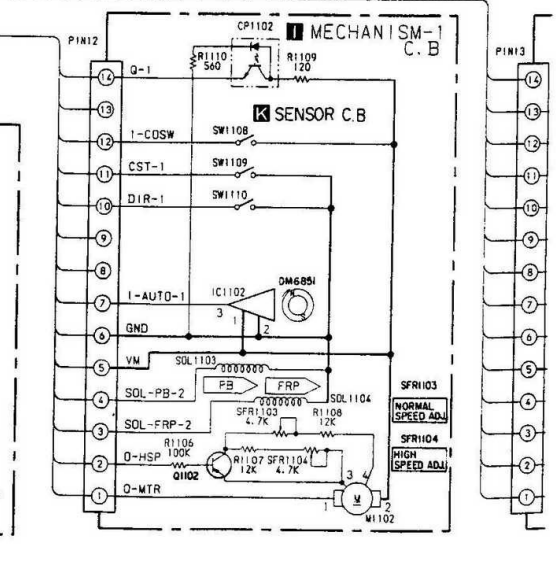
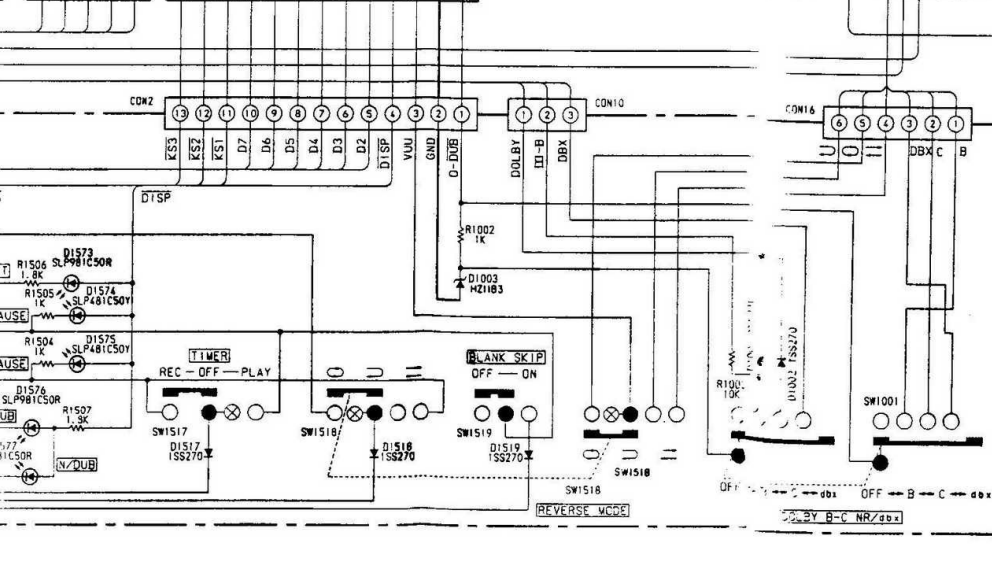
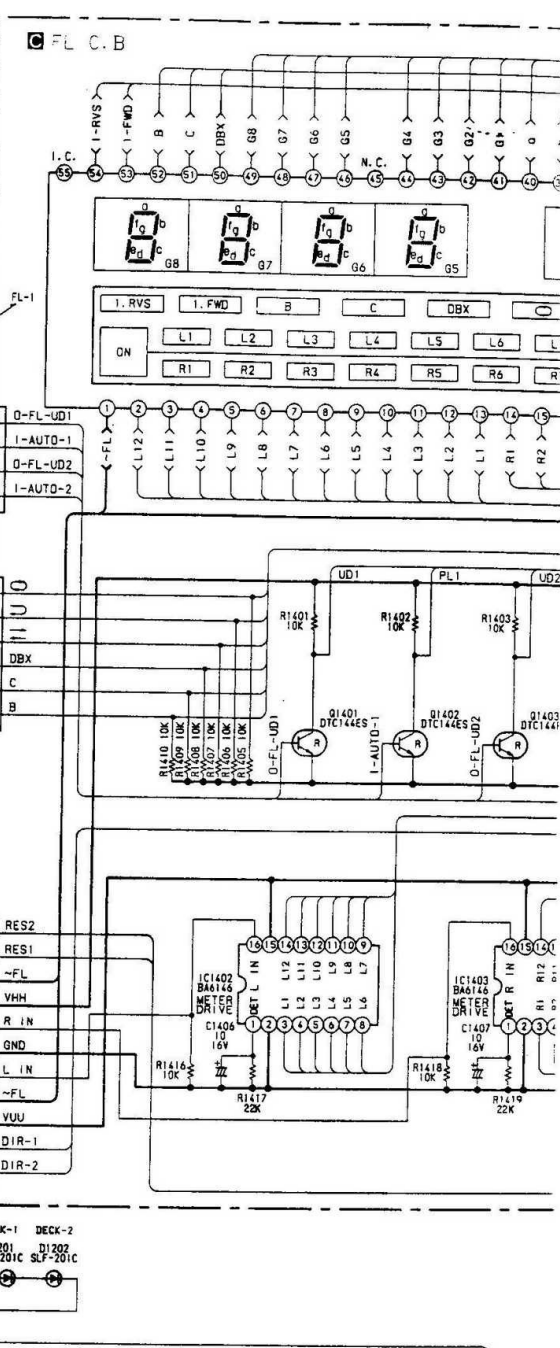
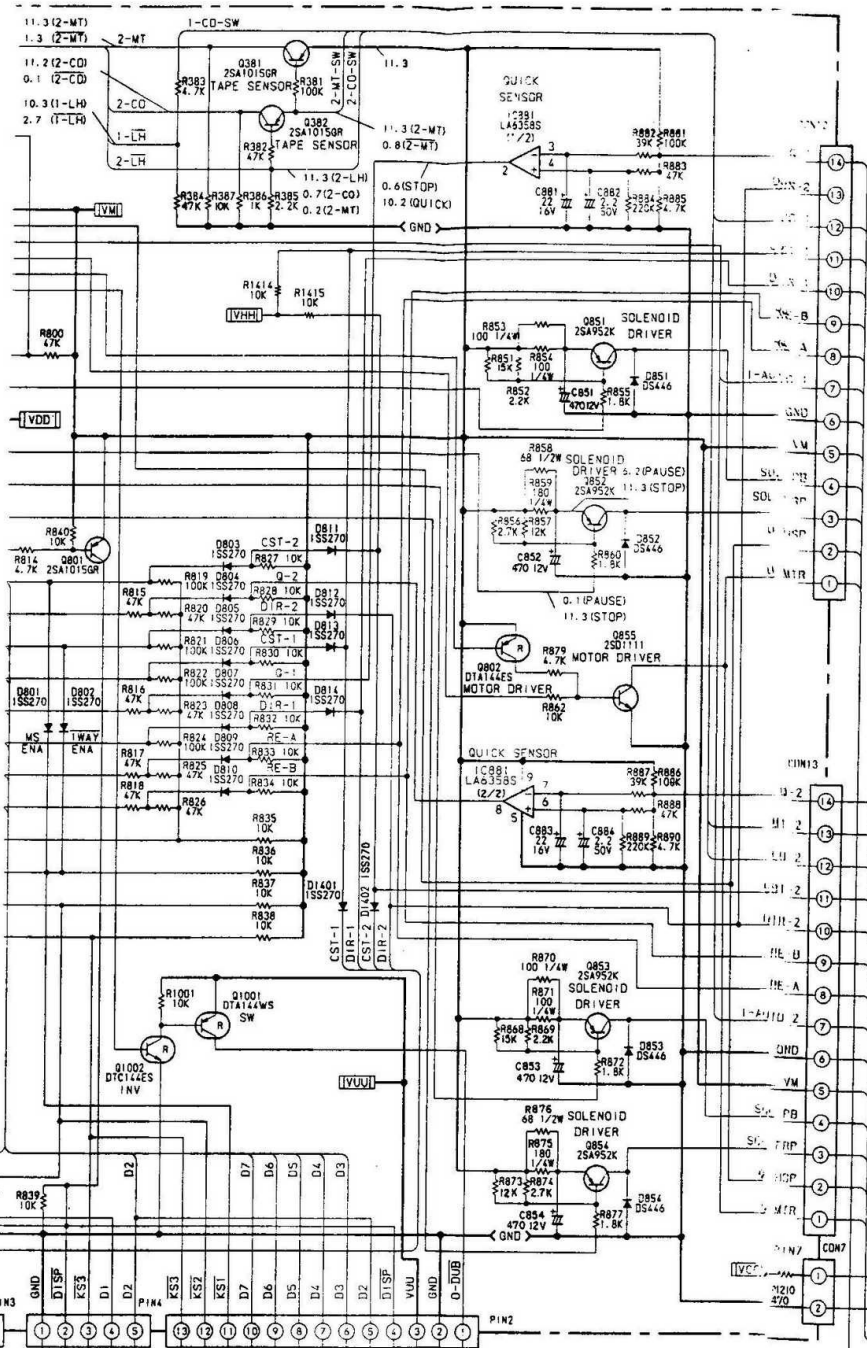

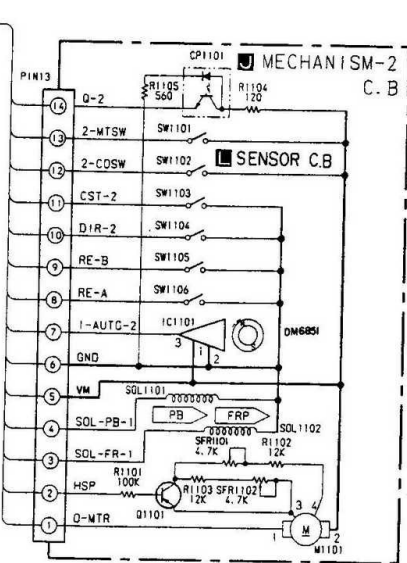
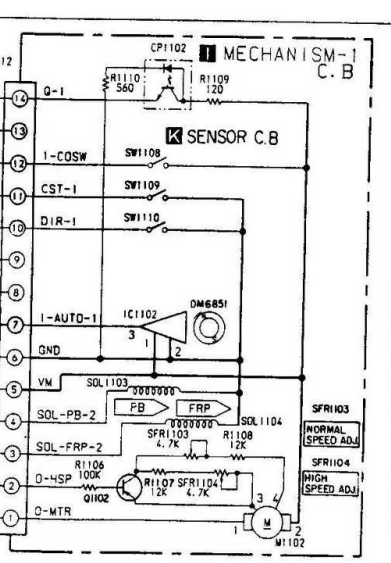
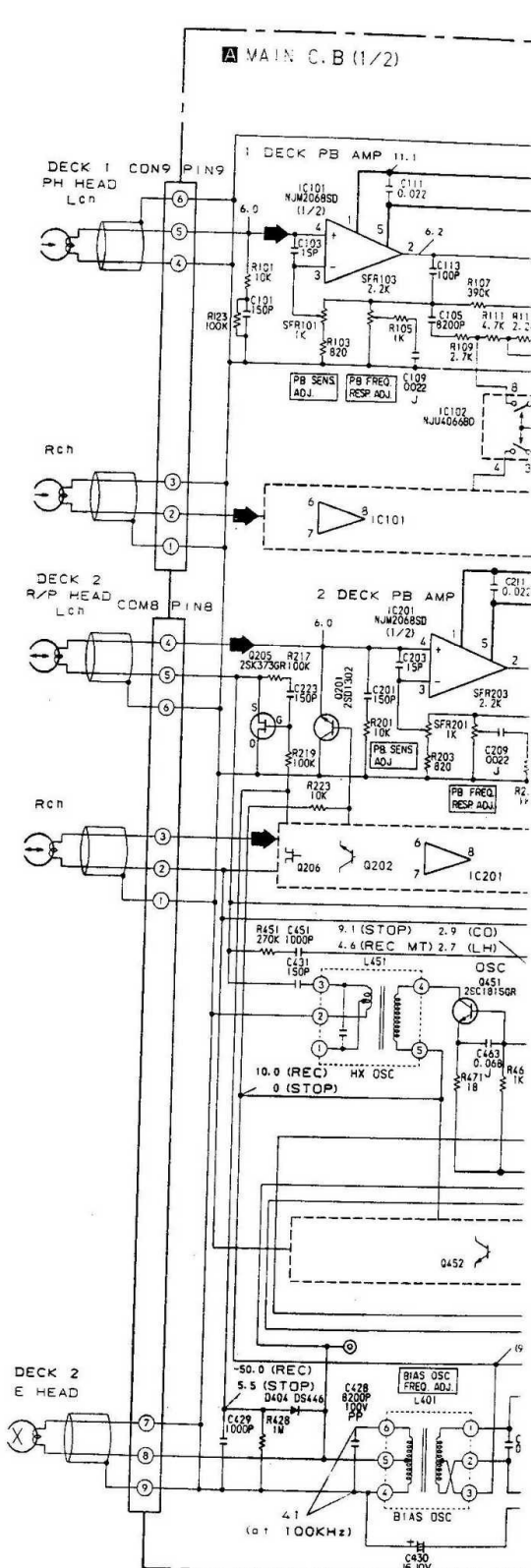
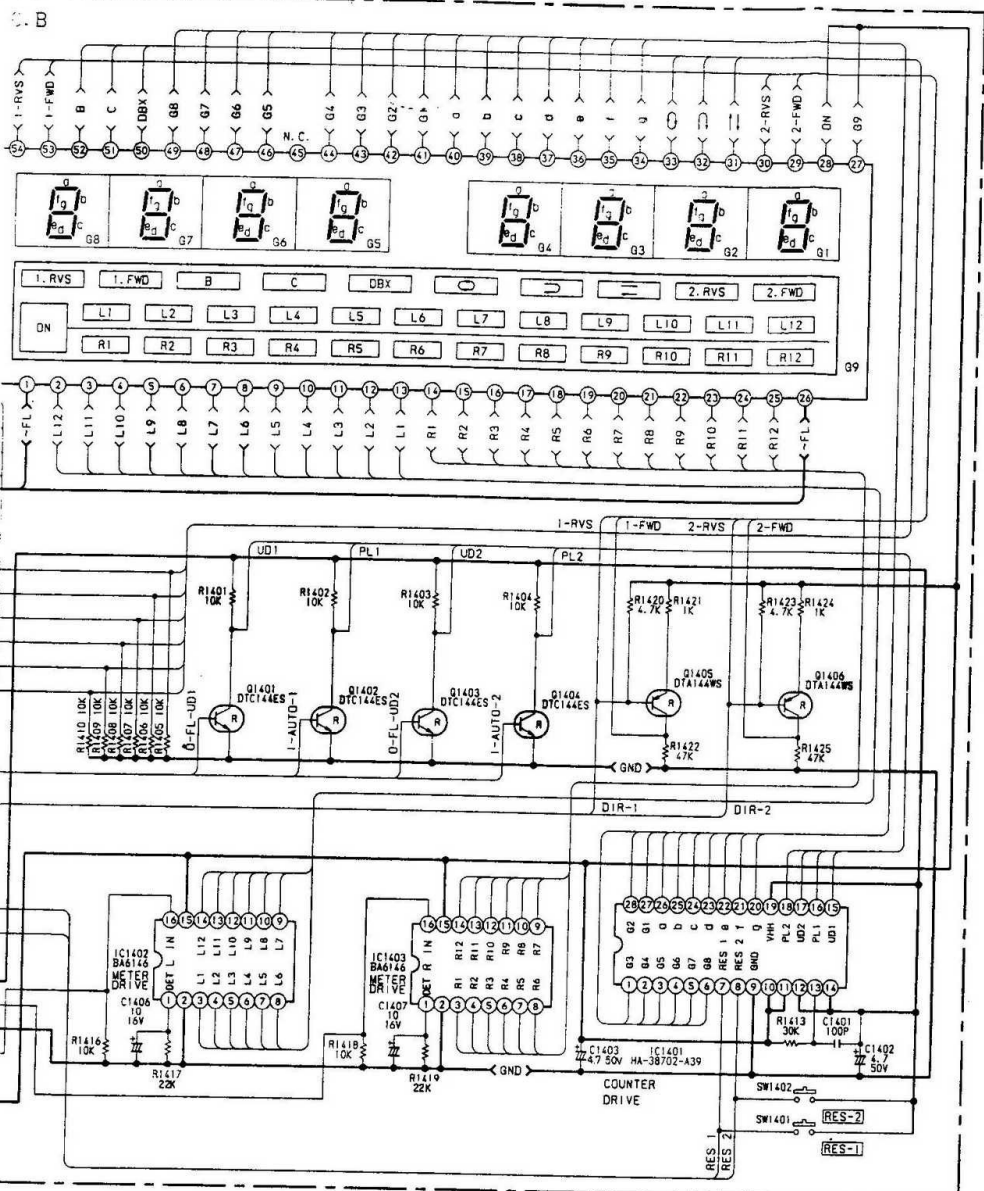

- 2SK373
- 2SA95
- 2SA10
- 2SC94
- 2SC18
- 2SC20
- 2SD11
- 2SD13
- 2SC13

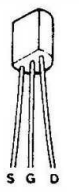
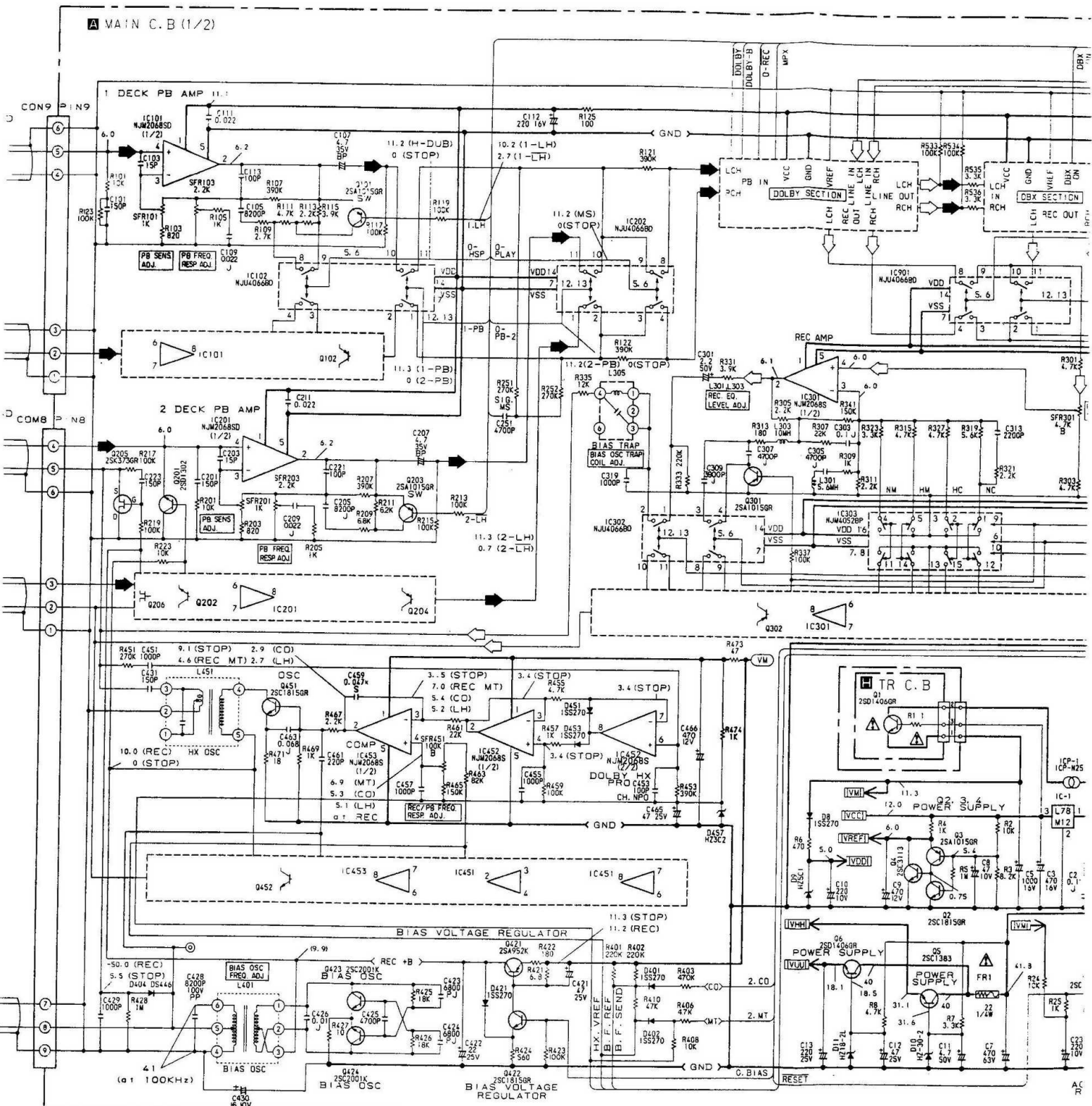

2SK373

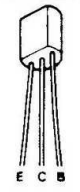

- 2SA952
- 2SA1015
- 2SC 945
- 2SC 1815
- 2SC 2001
- 2SD1111
- 2SD1302
- 2SC1383

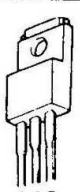

2SD1406



DT A144
2SC 3113

A
B
C
D
E
F
G
H
I
J

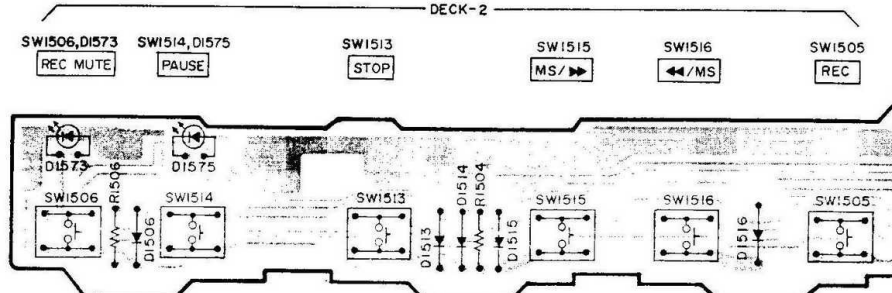
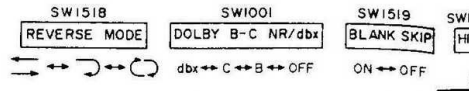

KEY C.B

MAIN C.B

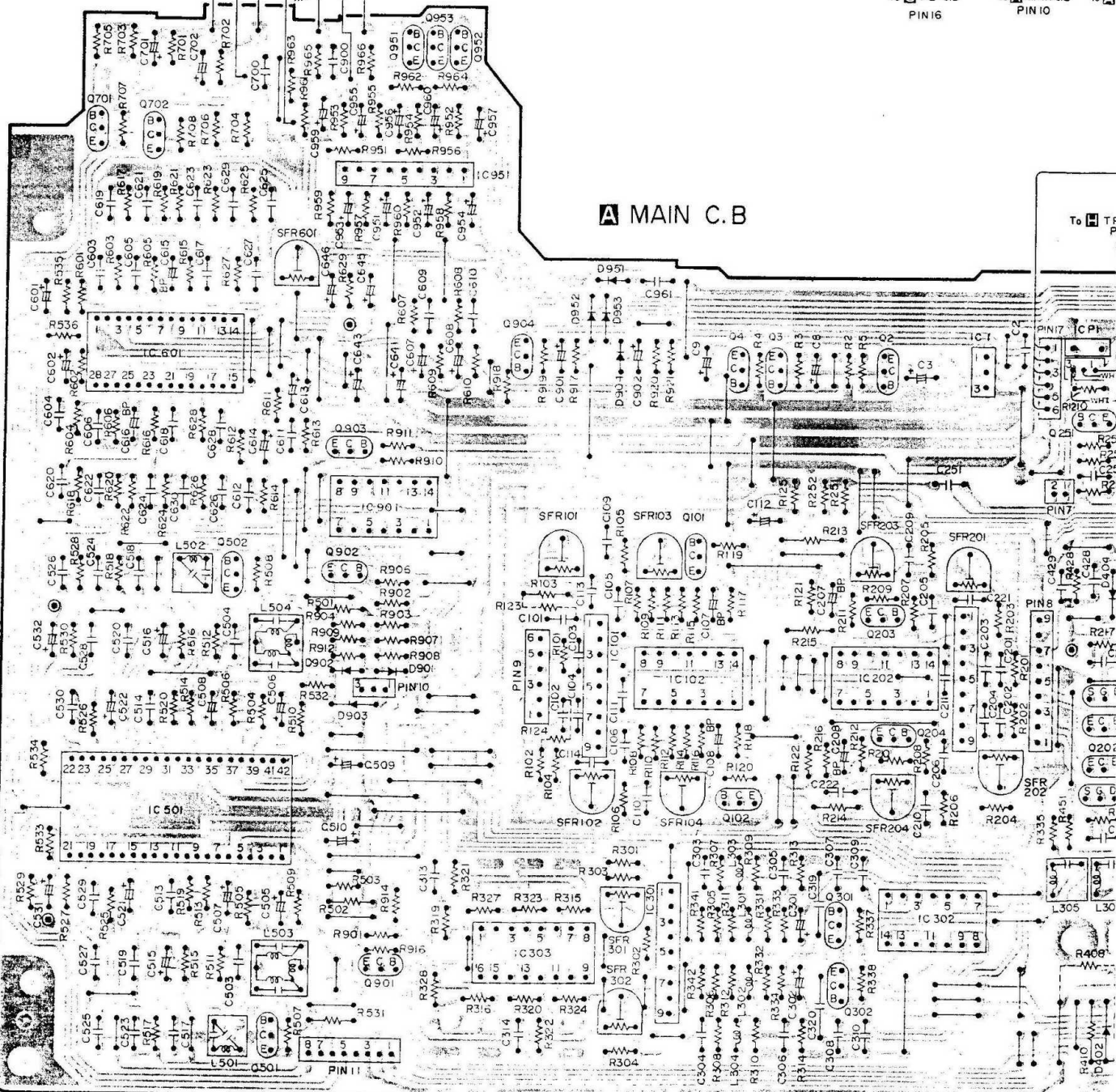

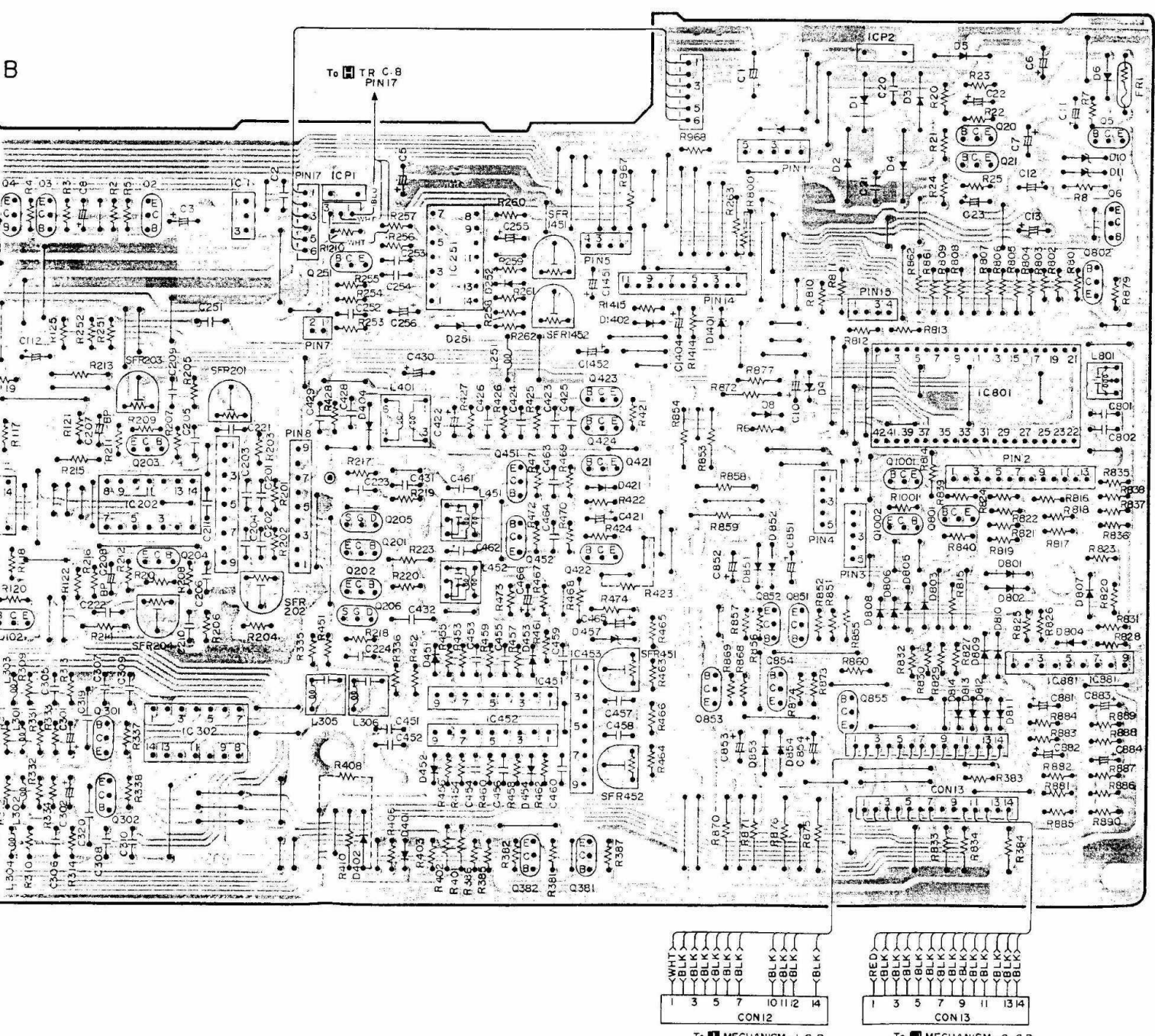
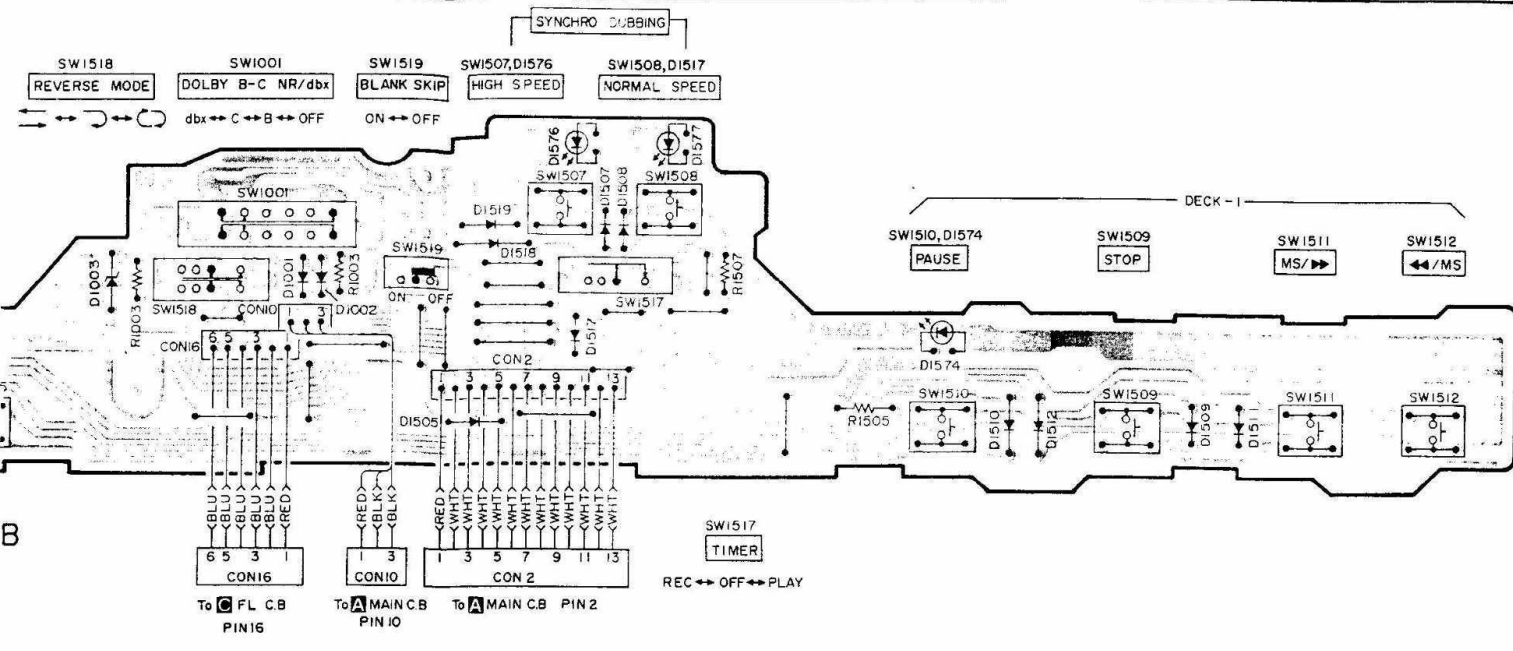

VL C.B

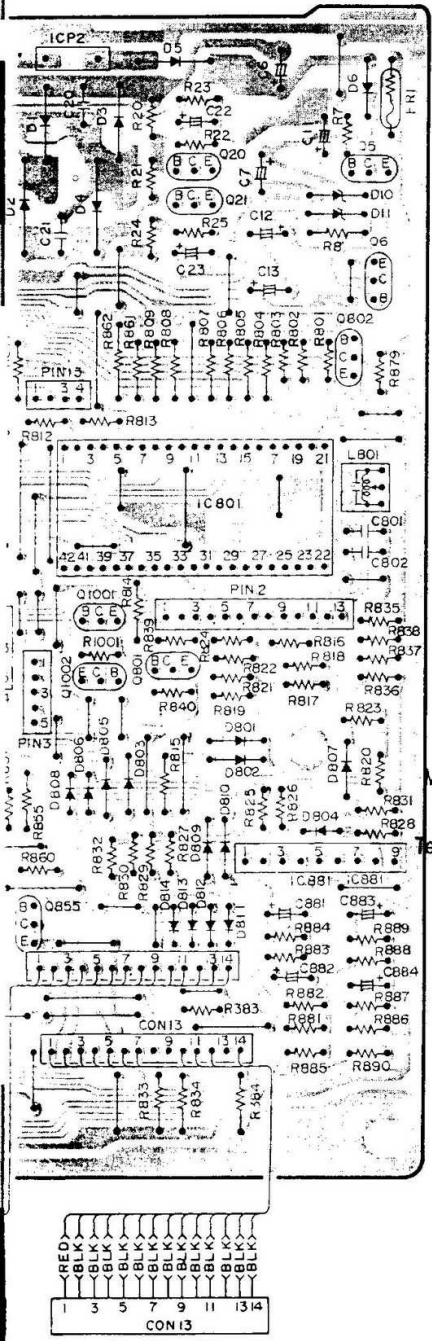
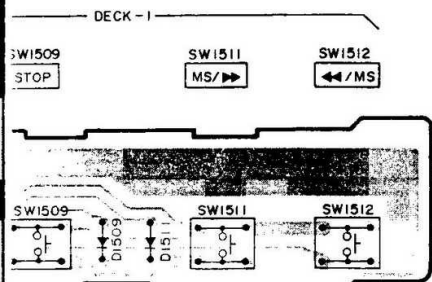
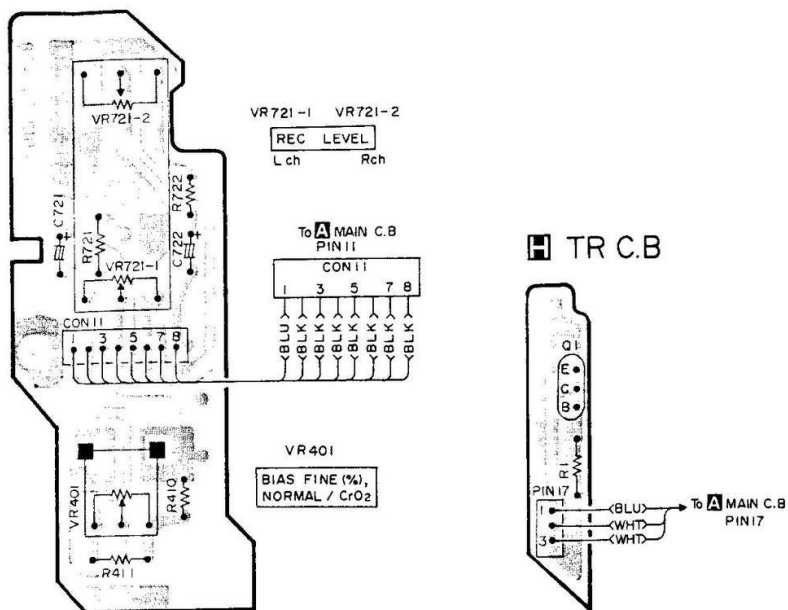

MECHANISM-1 C.B

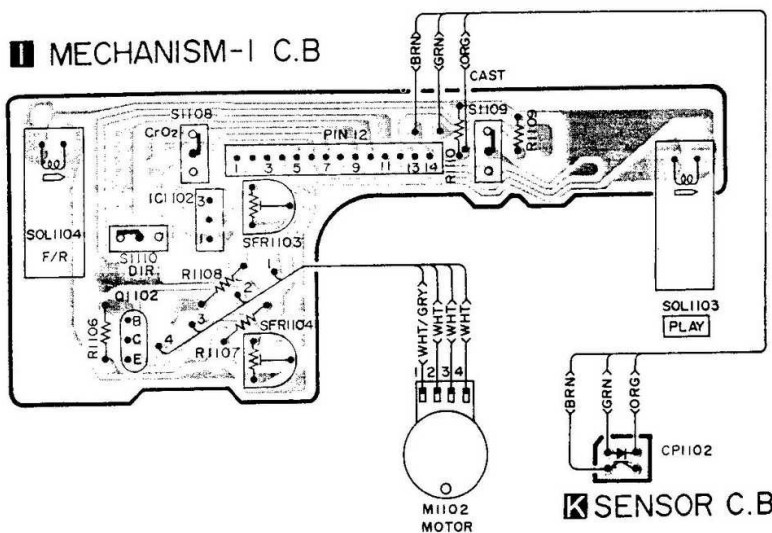

MECHANISM-2 C.B

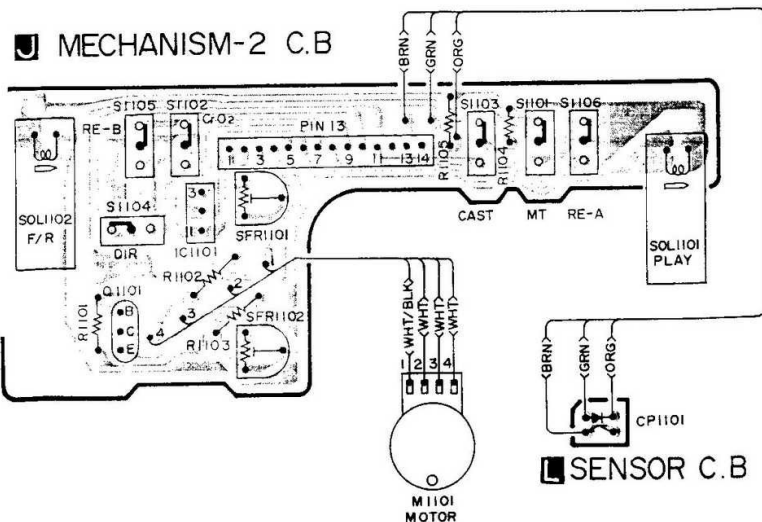

21-2
1ch

C.B
7 8
BLK
BLK

H TR C.B

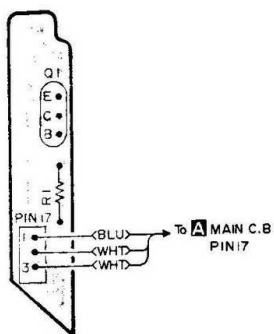

F SW-2 C.B

D1569~D1572 REC
D1565~D1568 PLAY

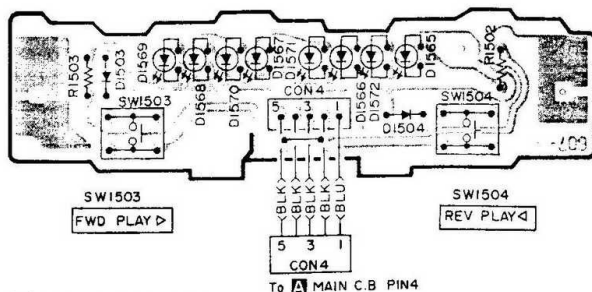

C FL C.B

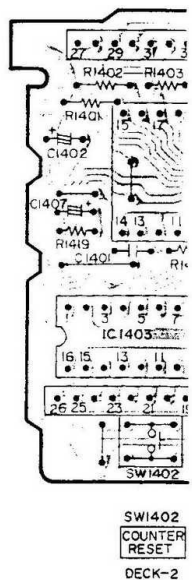

E SW-1 C.B

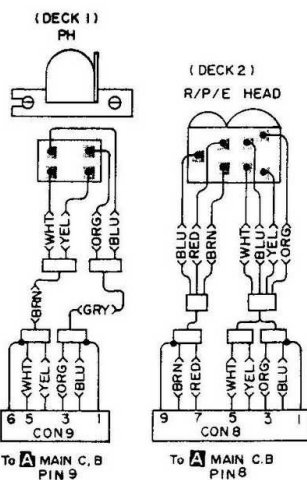
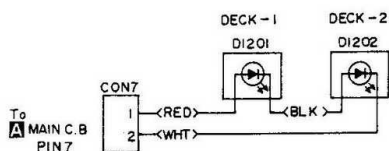
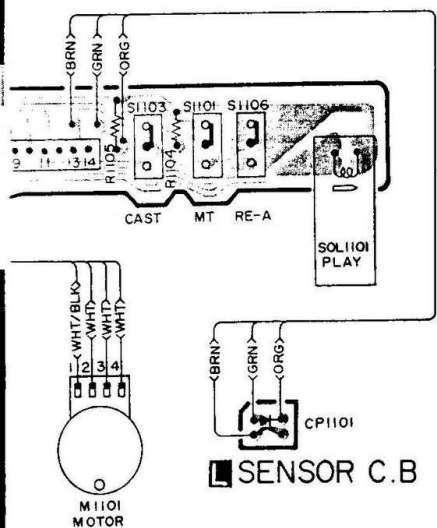
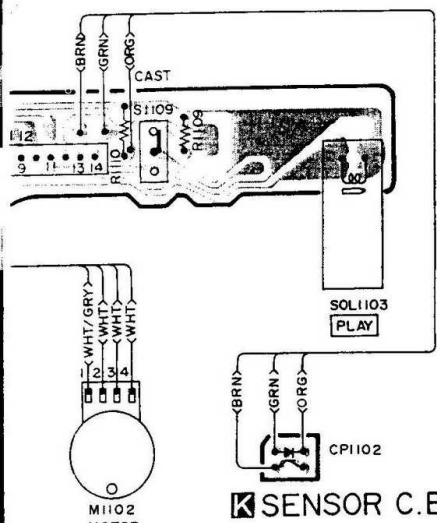
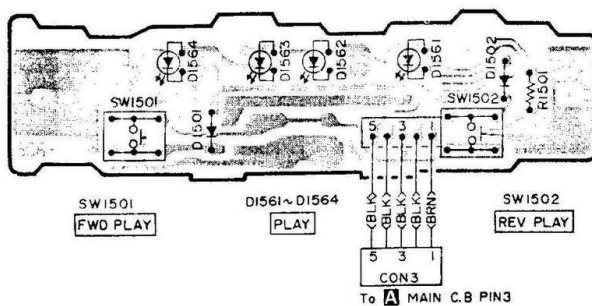

AC120V/220V/240V
50/60 Hz

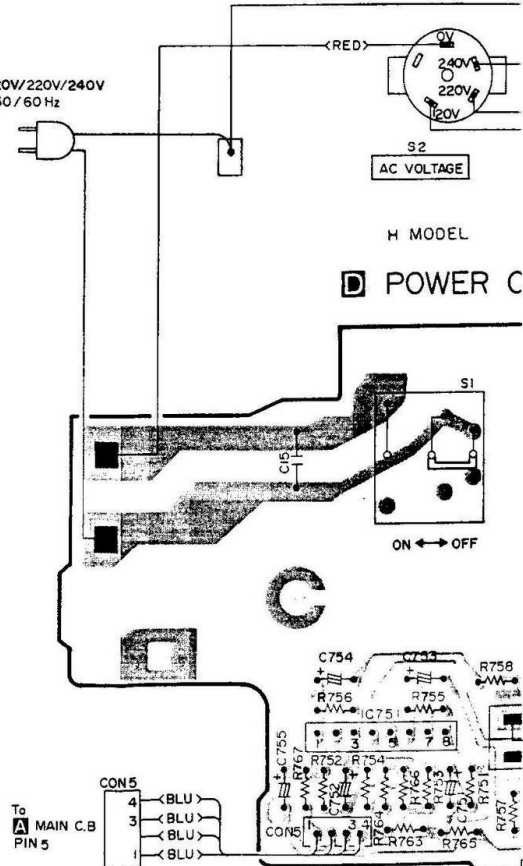

U MODEL
AC120V 60Hz
E, Z MODEL
AC220V 50/60Hz
K, G MODEL
AC240V 50/60Hz

D1565-D1568
PLAY

FL C.B

FL I
TAPE COUNTER/
12 POINT PEAK METER

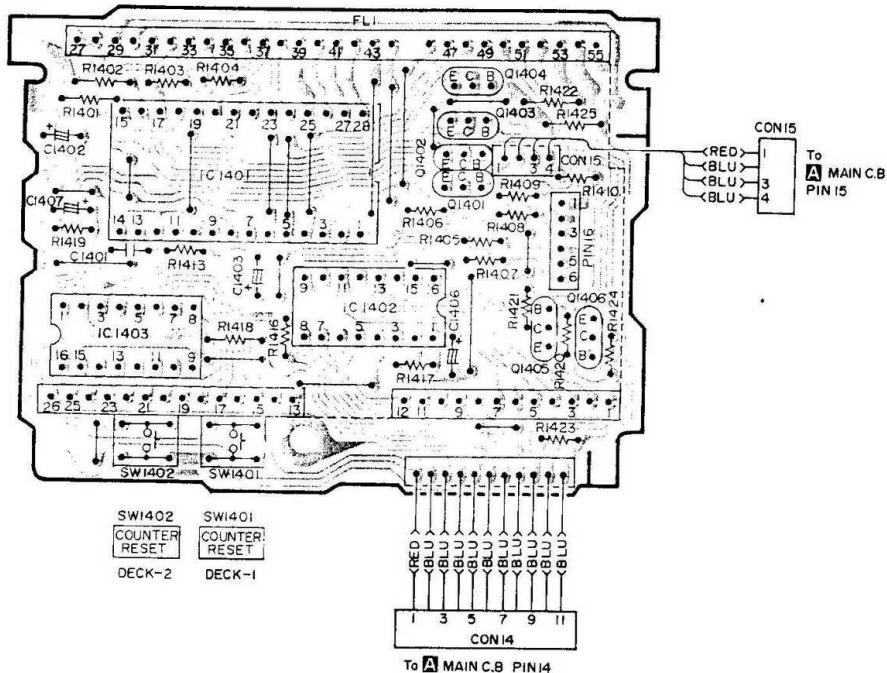

W1502
V PLAY

120V/220V/240V
50/60 Hz

D POWER C.B

H MODEL

PTI

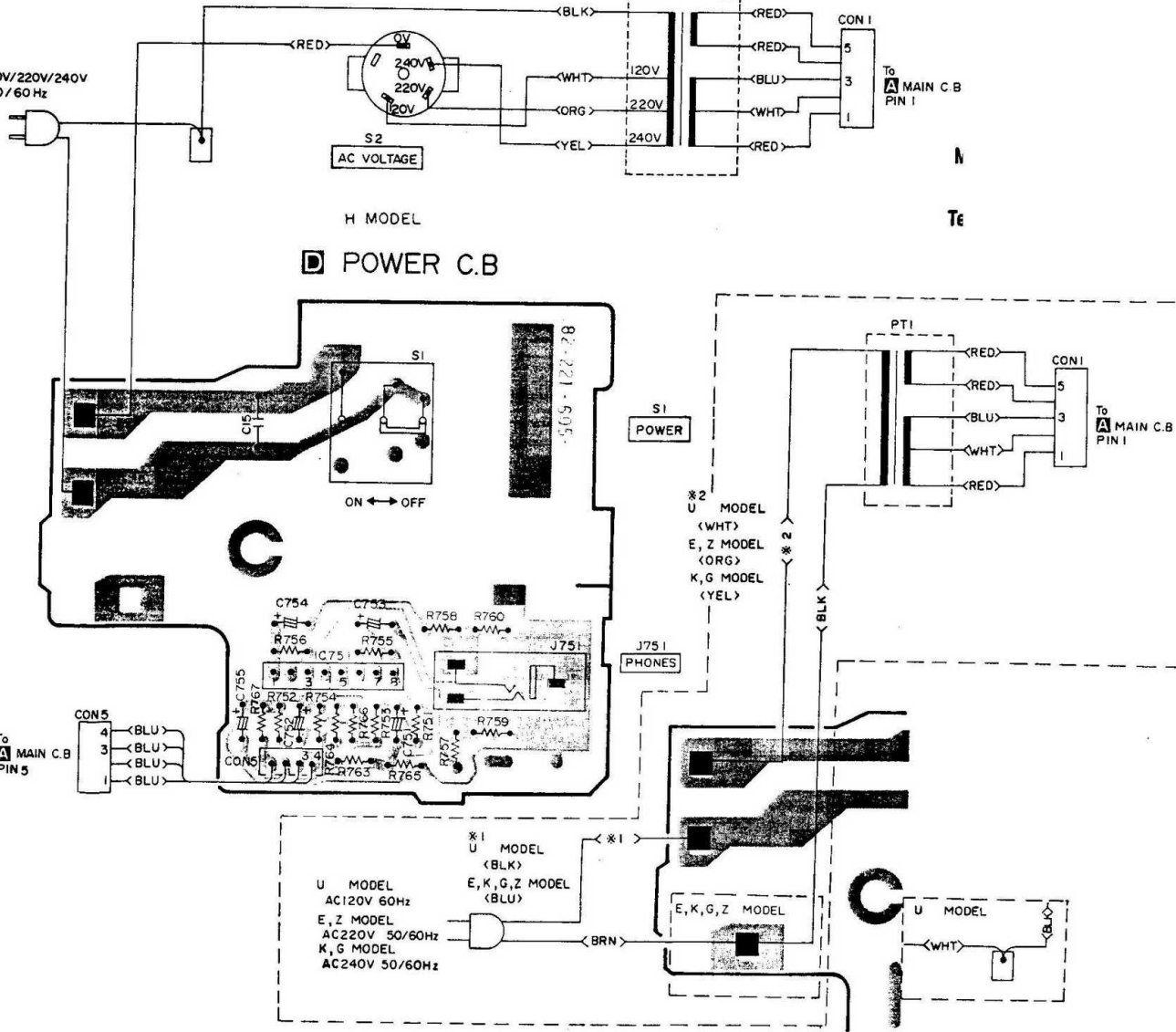

BLOCK DIAGRAM-1

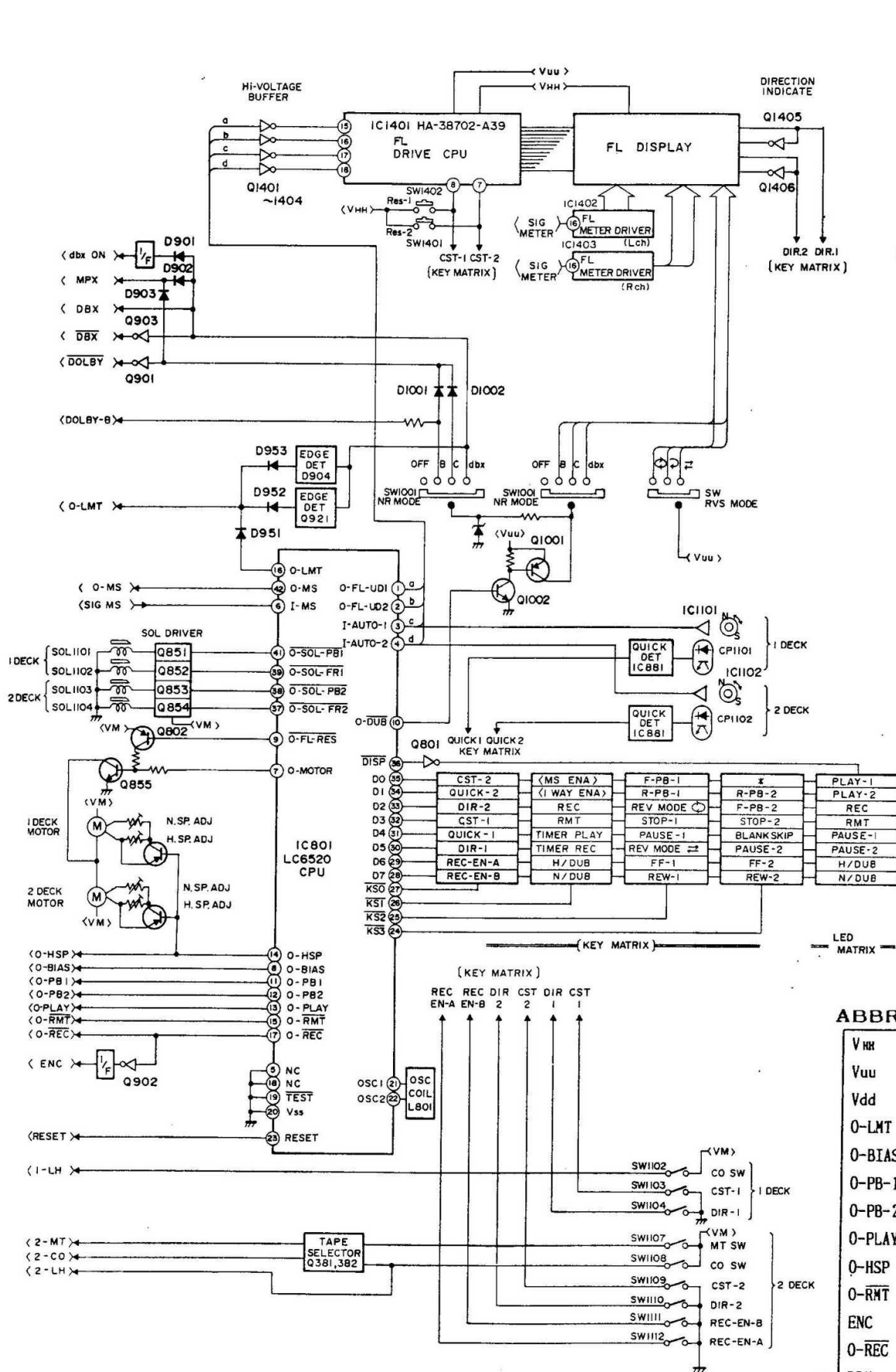

BLOCK DIAGRAM-2

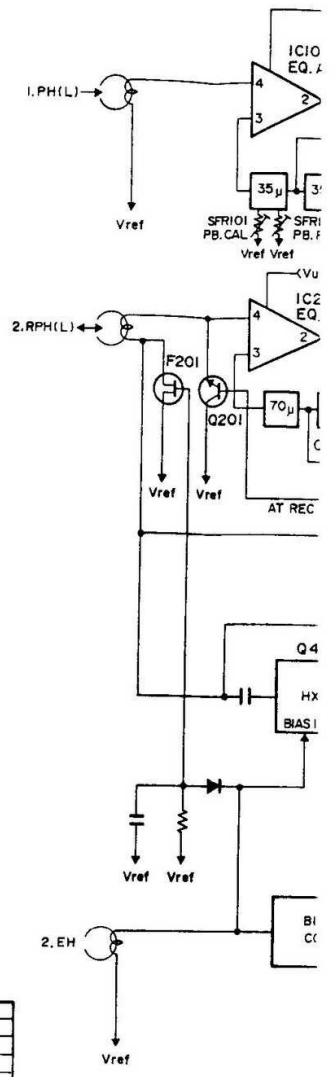

ABBREVIATIONS

V _{HH}	30V voltage doubler ar
V _{uu}	18V voltage doubler ar
V _{dd}	5V micro computer IC f
O-LMT	Line mute, dbx sw mute
O-BIAS	Bias osc control.
O-PB-1	1 tape deck mute contr
O-PB-2	2 tape deck mute contr
O-PLAY	CUE/REV mute control.
O-HSP	Hi-speed mode control.
O-RMT	REC MUTE control.
ENC	dbx IC ENC/DEC switchi
O-REC	Dolby IC REC/PLAY swit
DBX	REC OUT SELECT: dbx·IC
DBX	REC OUT SELECT: Dolby
MPX	MPX filter ON/OFF swit
Dolby B	Dolby IC B/C switching
SIG-MS	MS circuit input signa
SIG-METER	meter driver input sig
dbx·ON	dbx IN on/off switchin
Dolby	Dolby on/off switching

BLOCK DIAGRAM-2

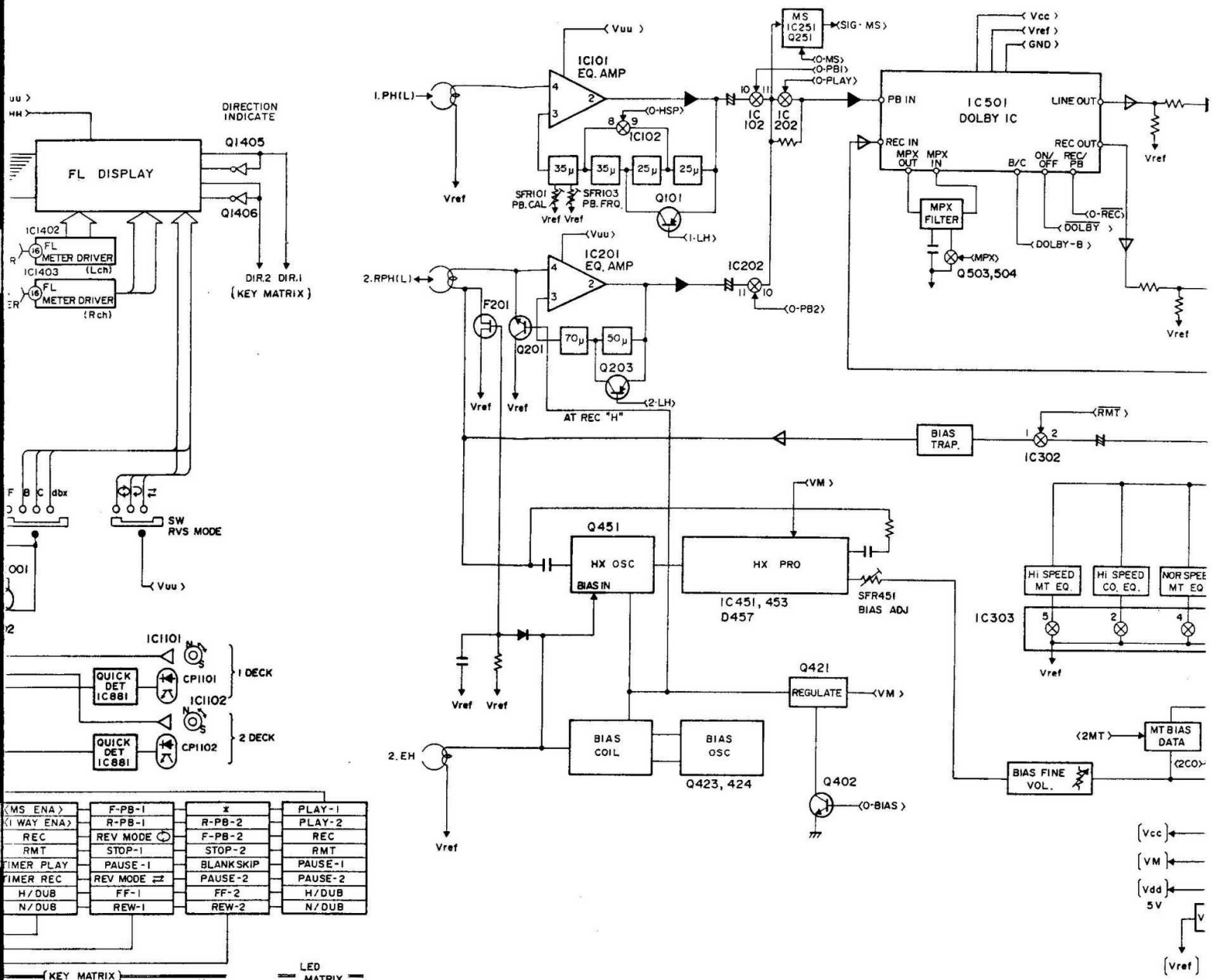

ABBREVIATIONS

V _{HH}	30V voltage doubler and regulator power source
V _{uu}	18V voltage doubler and regulator power source
V _{dd}	5V micro computer IC power source.
O-LMT	Line mute, dbx sw mute.
O-BIAS	Bias osc control.
O-PB-1	1 tape deck mute control.
O-PB-2	2 tape deck mute control.
O-PLAY	CUE/REV mute control.
O-HSP	Hi-speed mode control.
O-RMT	REC MUTE control.
ENC	dbx IC ENC/DEC switching signal.
O-REC	Dolby IC REC/PLAY switching signal.
DBX	REC OUT SELECT: dbx-IC
DB \bar{X}	REC OUT SELECT: Dolby IC
MPX	MPX filter ON/OFF switching signal
Dolby B	Dolby IC B/C switching signal.
SIG-MS	MS circuit input signal.
SIG-METER	meter driver input signal.
dbx-ON	dbx IN on/off switching signal.
Dolby	Dolby on/off switching signal.

ADJUSTMENT

- Normal Speed Adjustment (DECK-1)
 - Load the unit with a test ta and play its intermediate ar
 - Then adjust the variable res screwdriver through the adju so that the frequency counte
 - Check the reverse running of

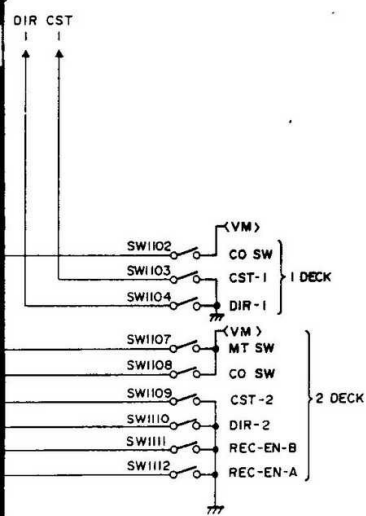

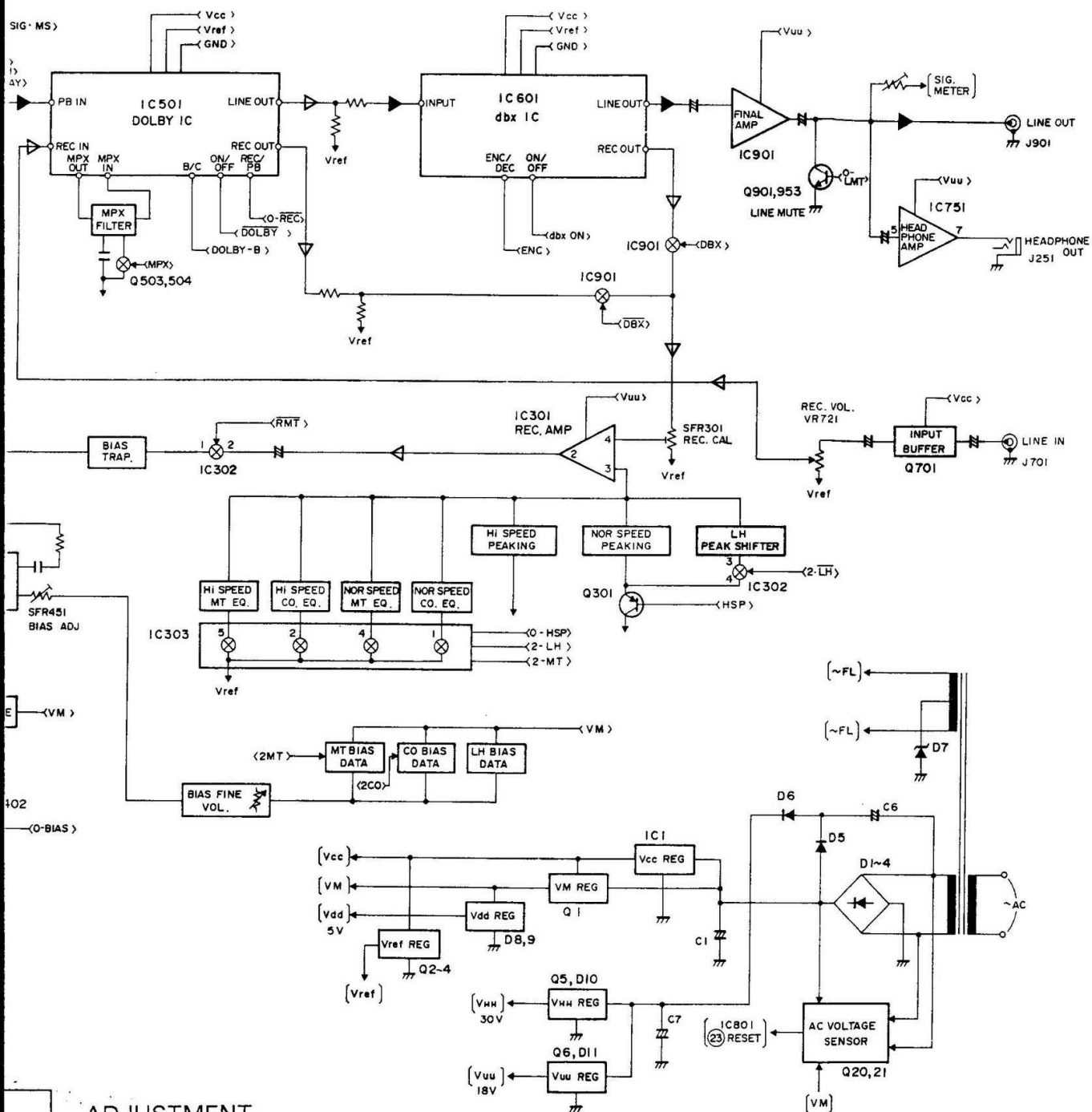

ADJUSTMENT

1. Normal Speed Adjustment (DECK-1, DECK-2)

1. Load the unit with a test tape (TTA-111S) and play its intermediate area.
2. Then adjust the variable resistor inserting a screwdriver through the adjustment SFR1103(1101) so that the frequency counter reads 3000Hz.
3. Check the reverse running of tape for DECK 2.

2. High Speed Adjustment (DECK-1, DECK-2)

1. Short-Circuit the pattern of the MOTOR P.C.B in the DECK to be adjusted as shown in Fig.
2. Load the unit with a test tape (TTA-111H) and play its intermediate area.
3. Adjust the variable resistor SFR1104(1102) so that the frequency counter reads 3000Hz
4. After adjustment is completed, release the short-circuit of the pattern.

Note : Always perform the normal speed adjustment and then the high-speed adjustment. Adjusting the high-speed only will cause an error in the normal tape speed.

3. Head A:
Setting:

Method

Note :

4. PB Fre:
Setting:

Method

I MECHANISM-1 C.B
J MECHANISM-2 C.B

DECK 2
R/P/E HEAD

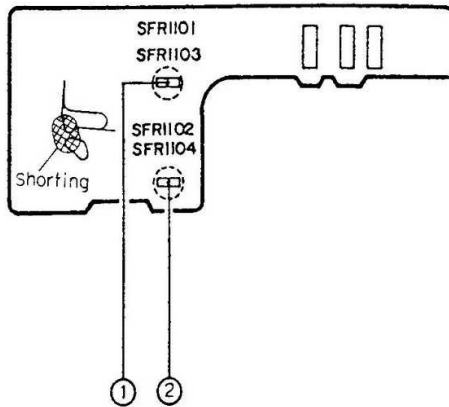

A MAIN C.B

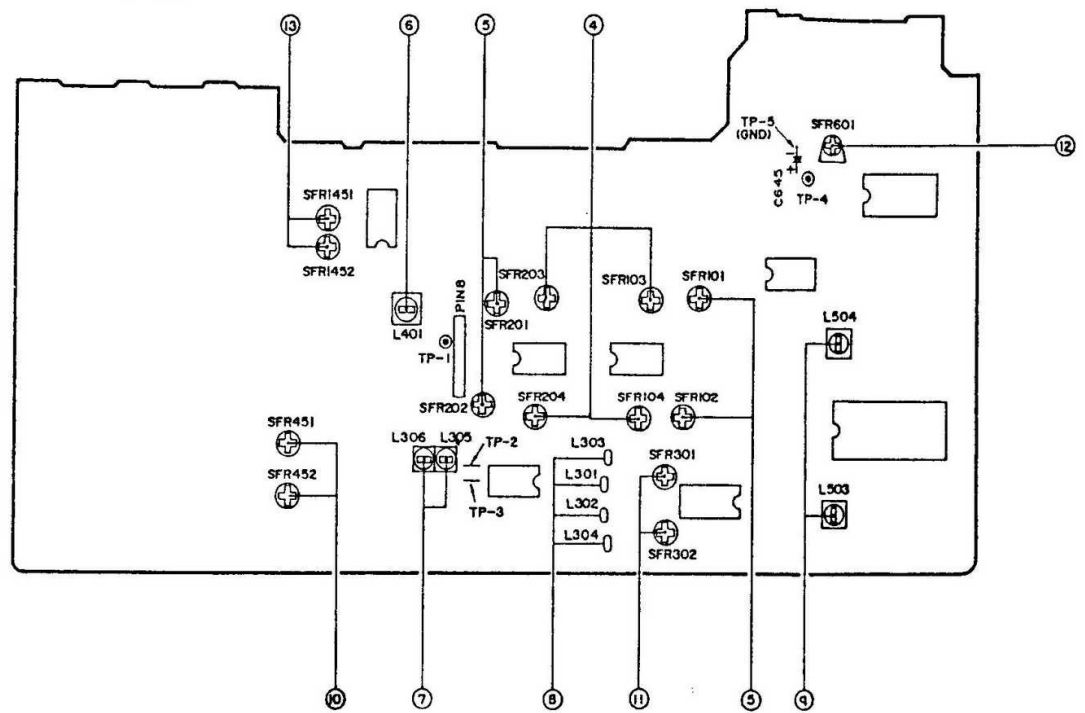

3. Head Azimuth Adjustment (DECK-1, DECK-2)

- Settings: • Test tape: SCC-1429 (TTA-317E)
- Test point: LINE OUT
- Adjustment location: Head azimuth adjustment screw

Method: Play back the test tape, and adjust so that the output becomes maximum.

Note: Perform on each PLAY and REV PLAY mode.

4. PB Frequency Response Adjustment (DECK-1, DECK-2)

- Settings: • Test tape: SCC-1429 (TTA-317E)
- Test point: LINE OUT
- Adjustment location: SFR103 (DECK-1, Lch)
- SFR104 (DECK-1, Rch)
- SFR203 (DECK-2, Lch)
- SFR204 (DECK-2, Rch)

Method: Play back the test tape, and adjust so that the output becomes $+0.3 \pm 0.2$ dB.

5. PB Sensitivity Adjustment (DECK-1, DECK-2)

- Settings: • Test tape: TCC-130 (TTA-161)
- Test point: LINE OUT
- Adjustment location: SFR101 (DEC)
- SFR102 (DEC)
- SFR201 (DEC)
- SFR202 (DEC)

Method: Play back the test tape, and adjust becomes 560 ± 10 mV.

6. Bias OSC Frequency Adjustment (DECK-2)

- Settings: • Test tape: TTA-119K
- Test point: TP-1
- Adjustment location: L401

Method: Adjust so that the output frequency

7. Bias OSC Trap Coil Adjustment (DECK-2)

Settings: • Test tape: TTA-119K

• Test point: TP-2 (Lch)

TP-6 (Rch)

• Adjustment location: L305 (Lch)

L306 (Rch)

Method: Record the test tape, and adjust for minimum output.

8. REC Equalizer Level Adjustment

Settings: • Test tape: Metal tape

• Input level: -20VU (40mV at LINE OUT)

• Test point: TP-2 (Lch)

TP-3 (Rch)

• Adjustment location: L301, L303 (Lch)

L302, L304 (Rch)

Method: Record the test tape, adjust so that the output becomes minimum at the peak level (about 20kHz).

9. MPX Filter Adjustment

Settings: • Test tape: Blank tape

• Input signal: 19kHz signal at LINE IN

• Test point: LINE OUT

• Adjustment location: L503 (Lch)

L504 (Rch)

Method: Record the test tape, and adjust so that the output at DOLBY B/C SW ON becomes up to 27dB for the output at DOLBY B/C SW OFF.

10. REC/PB Frequency Response Adjustment (DECK-2)

Settings: • Test tape: TTA-119K

• Output level: 40mV at LINE OUT

• Test point: LINE OUT

• Adjustment location: SFR451 (Lch)

SFR452 (Rch)

Method: Record the 1kHz and 10kHz signals, then play back the recorded tape and adjust so that the output difference between 1kHz and 10kHz becomes $+0.5\text{dB}$ $_{-0.5}^{\text{dB}}$.

11. REC/PB Sensitivity Adjustment (DECK-2)

Settings: • Test tape: TTA-119K

• Input signal: 400Hz (or 1kHz)

• Test point: LINE OUT

• Adjustment location: SFR301 (Lch)

SFR302 (Rch)

Method: Record the input signal and play back the test tape. Adjust so that the output difference between REC level and PB level becomes 40mV $_{-0.1}^{+0.3}\text{dB}$.

12. dbx Timing Current Adjustment

Settings: • Test point: TP4

TP5 (C645)

• Adjustment location: SFR601

Method: Adjust so that the output between testpoints becomes DC 18.4mV.

13. Peak Meter Adjustment

Settings: • Test tape: Blank tape

• Output level: 400mV at LINE OUT

• Adjustment location: SFR1451 (Lch)

SFR1452 (Rch)

Method: Adjust so that the peak meter (FL1) displays 0dB. Confirm that the peak meter displays correctly for -7, -2, +3, +6dB.

DECK 2
R/P/E HEAD

DECK 1
P HEAD

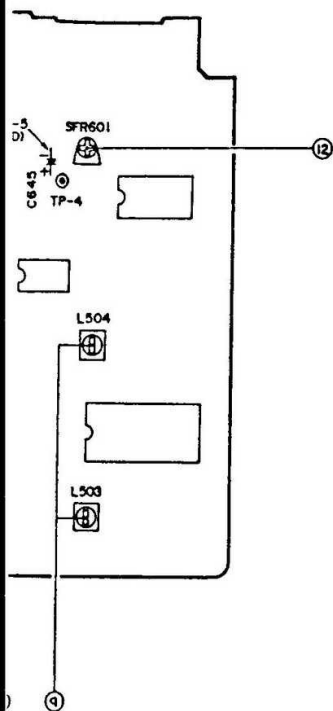
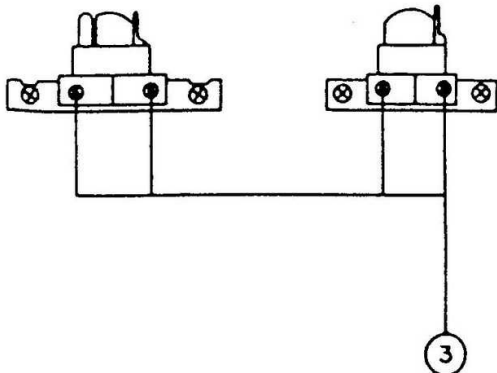

ty Adjustment (DECK-1, DECK-2)

Test tape: TCC-130 (TTA-161)

Test point: LINE OUT

Adjustment location: SFR101 (DECK-1, Lch)

SFR102 (DECK-1, Rch)

SFR201 (DECK-2, Lch)

SFR202 (DECK-2, Rch)

Play back the test tape, and adjust so that the output becomes $560 \pm 10\text{mV}$.

Frequency Adjustment (DECK-2)

Test tape: TTA-119K

Test point: TP-1

Adjustment location: L401

Adjust so that the output frequency becomes 100kHz $_{-0.5}^{+0}\text{kHz}$.

IC DESCRIPTION

LC6520H (IC801)

Pin No	Pin Name	Description
1	—	Pulled up to 10.8 V by a resistor.
2	—	Pulled up to 10.8 V by a resistor.
3	I-AUTO-1	DECK 1 auto-stop input. DECK 1 stops automatically without level change of "L" and "H".
4	I-AUTO-2	DECK 2 auto-stop input. DECK 2 stops automatically without level change of "L" and "H".
5	—	GND
6	—	Pulled down by a resistor and grounded.
7	O-MOTOR	Motor drive output (active "H"). Outputs "L" only when both DECKs 1 & 2 are in the stop mode. This pin outputs a signal 320 msec before SOL-PB and SOL-FRP, waiting for the O-MOTR rotating steadily.
8	O-BIAS	Bias oscillation output. Goes "L" during REC PAUSE and "H" during REC and DUBBING.
9	O-FL-RES	Outputs "H" when MPU is reset (initialized).
10	O-DUBB	Noise reduction control output during dubbing. Goes "L" during dubbing.
11	O-PB1	DECK 1 PB request output. Goes "L" when DECK 2 is in the play, play pause, cue and review modes.
12	O-PB2	DECK 2 PB request output. Goes "H" when DECK 1 is in the play; play pause, cue and review modes.
13	O-PLAY	CUE/REVIEW MUTE output. Goes "H" when the DECK which is selected by O-PB1 and O-PB2 is in the play mode.
14	O-HSP	Motor high-speed request output. Goes "H" at high-speed;
15	O-RMT	REC MUTE output. Goes "H" during REC and PLAY. Goes "L" during PAUSE, RMT and REC→REVERSE.
16	O-LMT	LINE MUTE output. Goes "L" during PLAY, CUE REVIEW, REC, REC PLAY, REC MUTE and REC→PAUSE.
17	O-REC	REC/PLAY switching output. Goes "H" during REC and REC REVERSE. Goes "L" during dubbing.
18	—	GND
19	TEST	MPU test pin connected to Vss
20	Vss	Common terminal (GND) of each input/output power of MPU.
21	OSC-1	4MHz clock oscillation pin.
22	OSC-2	4MHz clock oscillation pin.
23	RESET	MPU reset input. "H" resets the MPU.
24		} Refer to the next page.
36		
37	O-SOL-FRP2	DECK 2 / solenoid absorption output (active "L"). DECK 2 performs F.FWD/REW and CUE/REVIEW according to the absorption timing.
38	O-SOL-PB2	DECK 2 / solenoid absorption output (active "L"). DECK 2 performs PLAY, PAUSE and REVERSE according to the absorption timing.
39	O-SOL-FRP1	DECK 1 / solenoid absorption output (active "L"). DECK 1 performs F.FWD/REW and CUE/REVIEW according to the absorption timing.
40	VDD	MPU power pin connected to +5 V.
41	O-SOL-PB1	DECK 1 PB solenoid absorption output (active "L"). DECK 1 performs PLAY, PAUSE and REVERSE according to the absorption timing.
42	—	Pulled down by a resistor and grounded.

Pin No	Pin Name	Description					Output : LED Lights when DISP is "L"
		Input : Key DATA					
		Key SW IN = ON at "L", PULSE = ON at "H"					
		When KS3 is "L"	When KS2 is "L"	When KS1 is "L"	When KS0 is "L"		
35	DTφ	*	F.PLAY-1 KEY IN	MS-ENABLE	CST-2 SW IN	PLAY-1 LED OUT	
34	DT1	R.PLAY-2 KEY IN	REV-1 KEY IN	1-WAY-ENABLE	QUICK-2 PULSE IN	PLAY-2 LED OUT	
33	DT2	F.PLAY-2 KEY IN	REV.MODE ↻ SW IN	REC KEY IN	DIR-2 SW IN	REC LED OUT	
32	DT3	STOP-2 KEY IN	STOP-1 KEY IN	RMT KEY IN	CST-1 SW IN	RMT LED OUT	
31	DT4	BLANK SKIP SW IN	PAUSE-1 KEY IN	TIMER PLAY SW IN	QUICK-1 PULSE IN	PAUSE-1 LED OUT	
30	DT5	PAUSE-2 KEY IN	REV.MODE ⇄ SW IN	TIMER REC SW IN	DIR-1 SW IN	PAUSE-2 LED OUT	
29	DT6	FF-2 KEY IN	FF-1 KEY IN	H/DUB KEY IN	RE-A SW IN	H/DUB LED OUT	
28	DT7	REV-2 KEY IN	REV-1 KEY IN	N/DUB KEY IN	RE-B SW IN	N/DUB LED OUT	
27	$\overline{KS0}$	DTφ - DT7 KEY SCAN OUT					
26	$\overline{KS1}$						
25	$\overline{KS2}$						
24	$\overline{KS3}$						
36	DISP	DTφ - DT7 LED SCAN OUT					

PRACTICAL SERVICE FIGURE

Playback output : (TTA-161)	560±60mV (LINE OUT, 400Hz)	(WTD-A)	(DOLBY C NR OFF/ON with MT, CrO ₂ tapes) More than 46/61dB
PB/REC output : (TTA-119K)	400±50mV (LINE OUT, 1kHz)		(DOLBY C OFF/ON with NORM, tape) More than 72dB
PB/REC distortion :	Less than 1.5% (NORM) Less than 2.0% (MT, CrO ₂)		(dBx ON with MT, CrO ₂ and NORM tapes)
Playback noise :	Less than 1.2mV (DOLBY C NR ON, with CrO ₂ , NORM. tapes) Less than 3.5mV (DOLBY B NR OFF, with NORM. tapes)	Recording bias frequency : 100kHz	
Erase ratio (125Hz) :	More than 60dB	Tape speed : (TTA-111S)	3kHz ± 1.5%
PB/REC S/N ratio : 63dB (MT)	More than 47/62dB (CrO ₂), 63dB (MT)	Wow & flutter : (W. R. M. S)	Less than 0.065% (FWD)(DECK1,2)
		Take-up torque :	30~60g-cm (DECK1,2)
		Fast forward torque :	130 ± 30g-cm (DECK1,2)
		Rewind torque :	130 ± 30g-cm (DECK1,2)
		Back-tension :	2.5~5.5g-cm (DECK1,2)
		Pinch roller pressure :	290 ± 70g (DECK1,2)
		Test tape :	METAL TTA-119MP CrO ₂ TTA-119H NORMAL TTA-119K

CIRCUIT DESCRIPTION

The dbx Noise Reduction System

1. Overview

The dbx noise reduction system compresses signals that are recorded on tape and expands them when they are played back to extend dynamic range and substantively reduce noise level.

The tape used in cassette tape decks has saturation and noise levels (tape hiss) that permit only a very narrow, 55dB dynamic range. This is why the inputting of a program with a dynamic range wider than 55dB will saturate and clip large signals and bury small signals in noise level.

Before recording, the dbx noise reduction system accurately compresses, by one-half algebraic value, recording signals, even those from wide dynamic range program sources. Compressing a program source's 80dB dynamic range to 40dB width, for example, records all program sources in the cassette deck's dynamic range without distortion and burying in noise. The signal is expanded during playback to double what it was, i.e., expanded to an 80dB program source, which is the original dynamic range. This is an effective means of overall noise reduction because, at this time, noise level will also decrease over the entire range by about 30dB. This also improves saturation level, equivalently, by about 10dB.

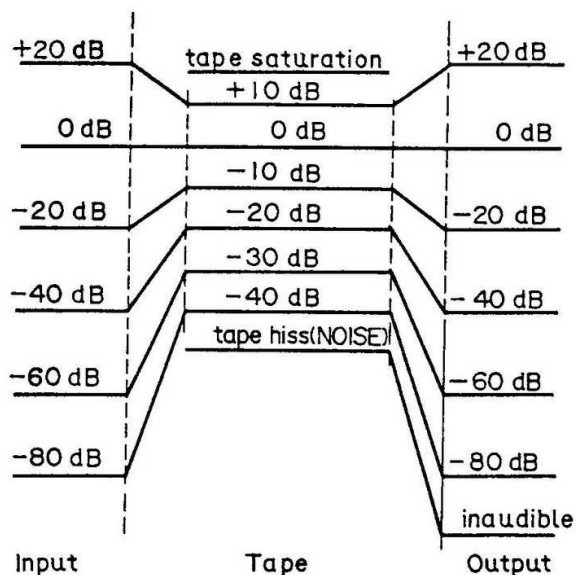

2. Operations in each mode

The switches in the IC are changed over depending on the levels at pins 15 and 16, and dbx turning off, encoding and decoding are performed. The following describes the flow of signals and operation of circuits in each mode.

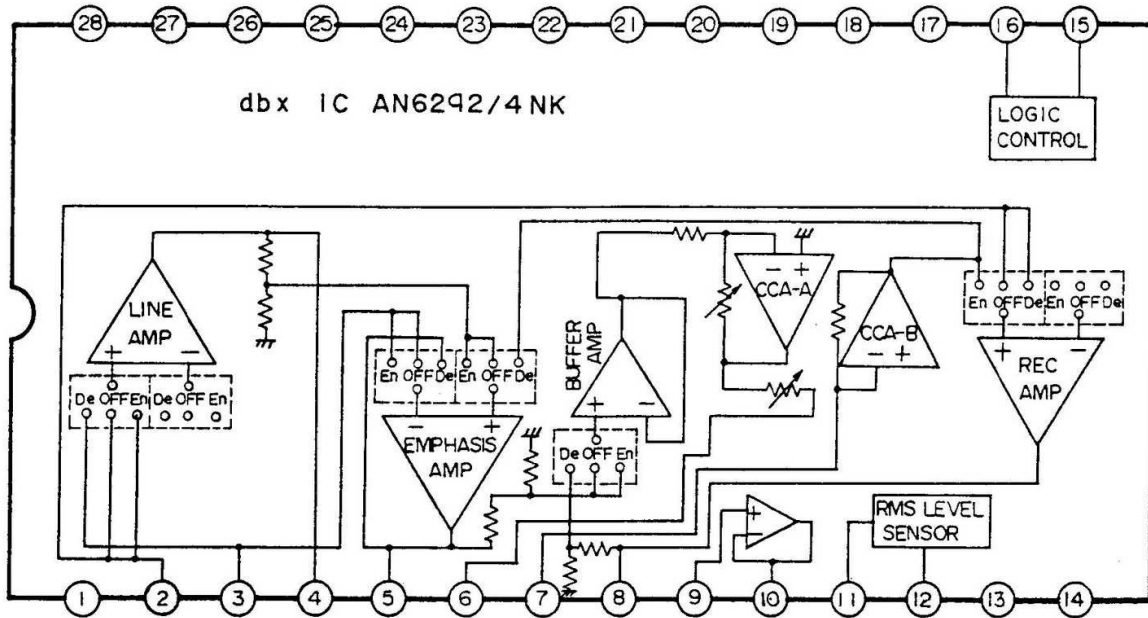

1) dbx-OFF (BYPASS MODE)

The signal that enters pin 2 passes through LINE AMP to be output through pin 4. The signal becomes playback output during playback and monitor output during recording. The signal input to pin 2 also passes through the REC AMP to be output through pin 8. But if dbx is OFF, the analog switch in IC901 prevents output from pin 8 going to the recording circuits.

The remaining sections (EMPHASIS AMP, BUFFER, CCA-A and CCA-B) have no connection with this operation.

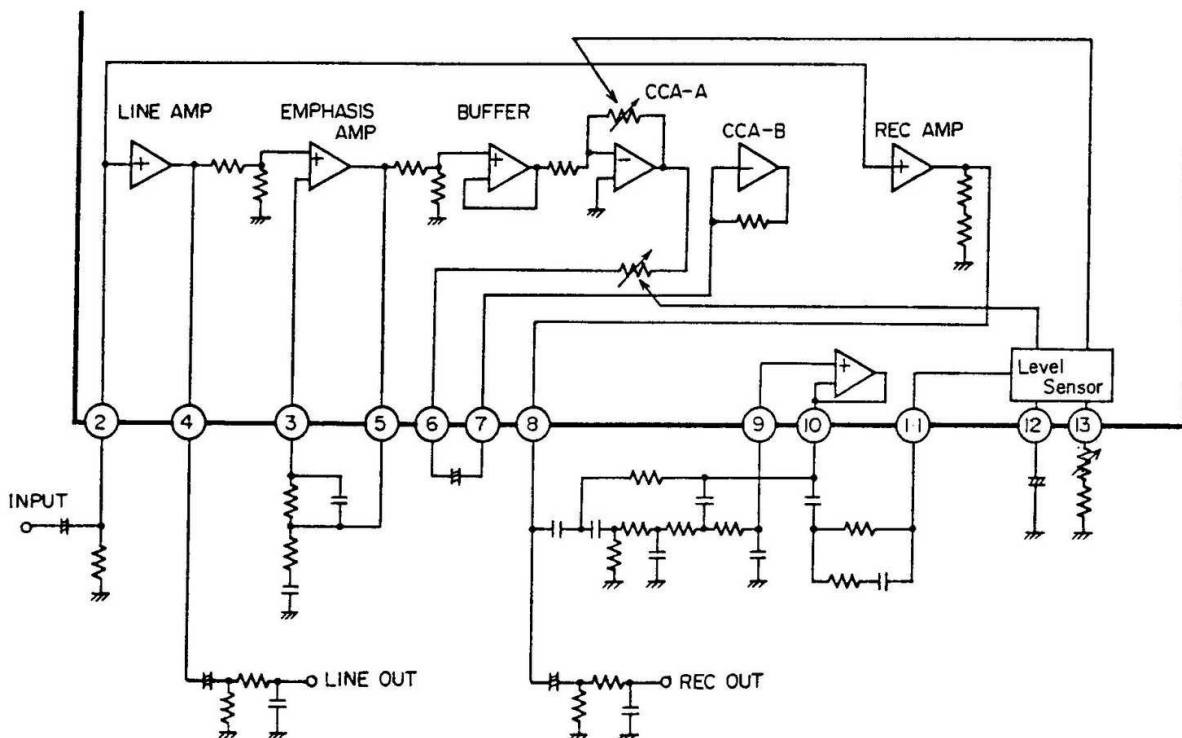

2) dbx playback (DECODE MODE)

Signal input to pin 2 passes through the REC AMP, then through the RMS BPF and the RMS PRE-EMPHASIS to be input to pin 11 and then to the LEVEL SENSOR.

The output which has left the REC AMP passes through the BUFFER to enter the CCA-A whose gain is controlled by the control signals from the LEVEL SENSOR. The signal passes out of pin 6, reenters pin 7, passes through CCA-B, the EMPHASIS AMP and LINE AMP to be output from pin 4 as playback output.

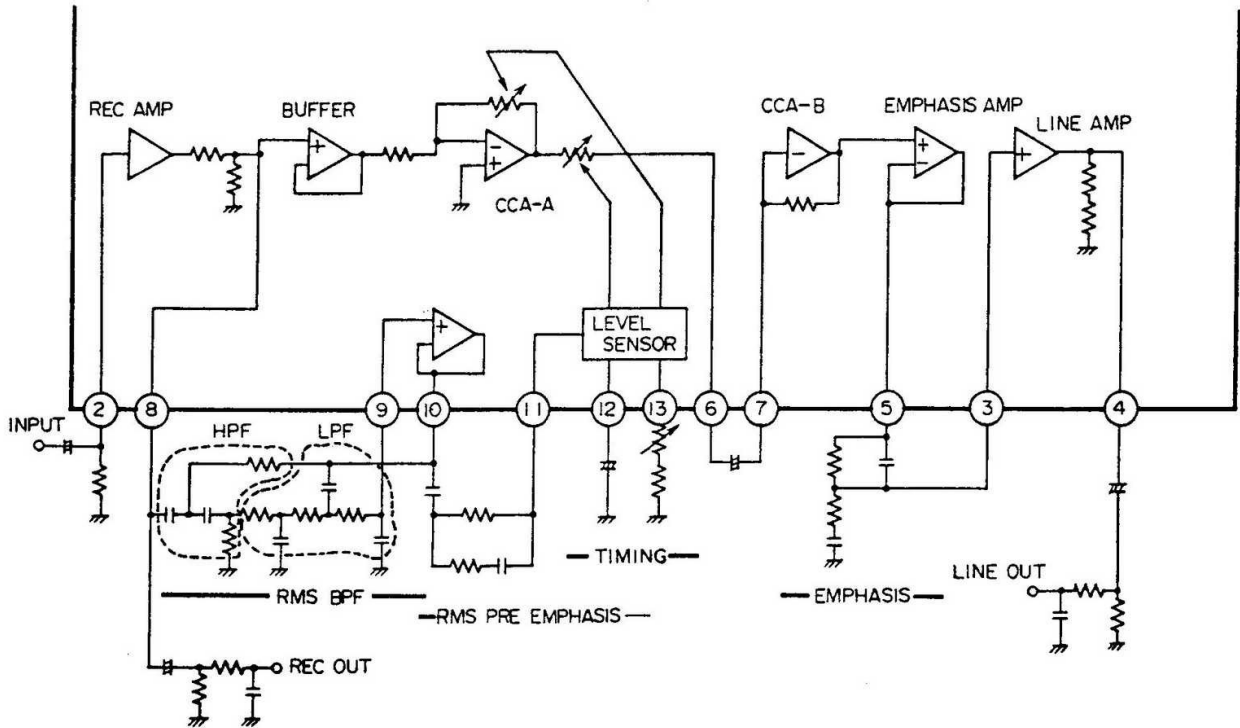

6292/94NK Decode Mode (During dbx playback)

Signal levels during Dolby level tape playback (TTA-161) (dbx ON)

PIN	1	2	3	4	5	6	7	8	9	10	11	12	13	14	15	16
SIG. LEVEL (VP-P)	0	5.0	1.2	5.0	1.9	0	0	5.0	4.4	4.6	0	0	0	0	0	0

3) dbx Record (ENCODE MODE)

Signal input to pin 2 passes through the LINE AMP, EMPHASIS AMP and BUFFER to enter the CCA-A which outputs it through pin 6. The signal then passes through a capacitor and reenters through pin 7 to go through CCA-B and the REC AMP to be output through pin 8 and sent to the recording circuits.

Output from pin 8 passes through the RMS BPF and RMS PRE-EMPHASIS then goes through pin 11 and into the LEVEL SENSOR. The LEVEL SENSOR sends control signals to CCA-A that control CCA-A's gain. LINE AMP output goes through pin 4 for use as a recording monitor signal.

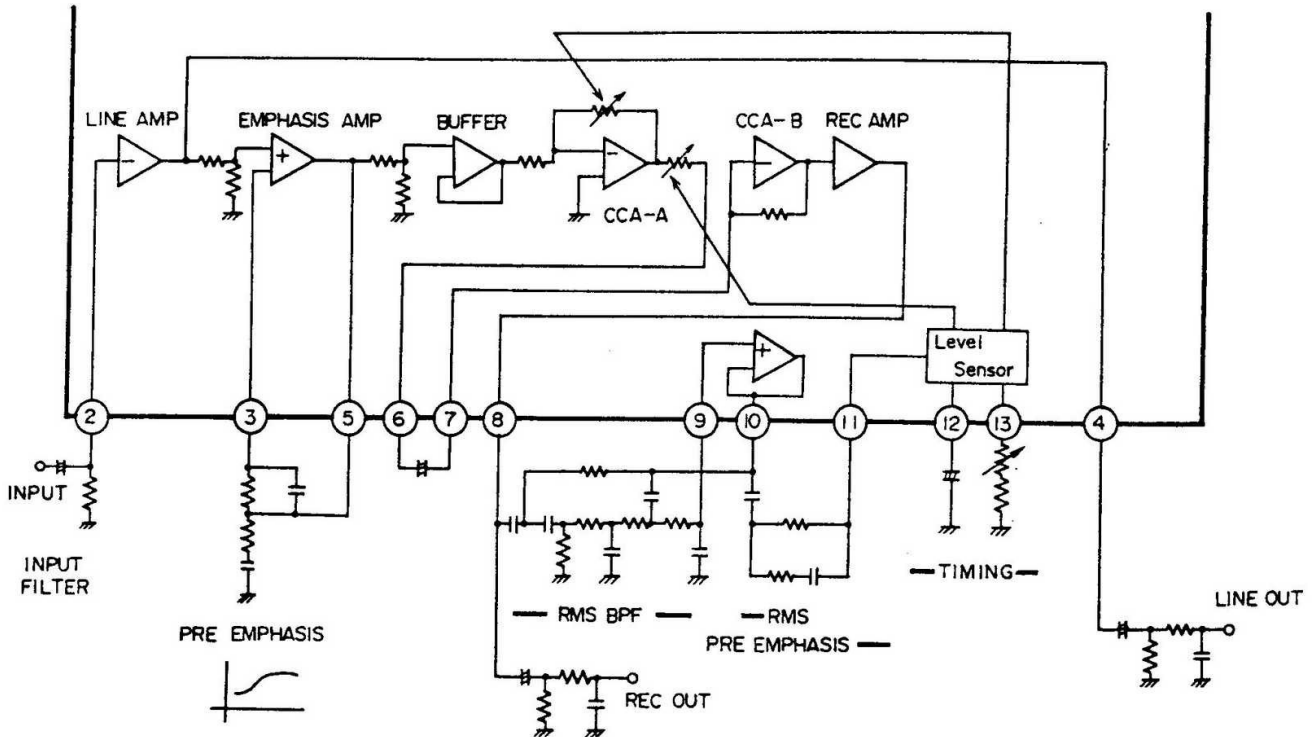

3. Functions of each section

1) RMS LEVEL SENSOR

This sensor creates the signal that controls the gain of CCA (CURRENT CONTROL AMP). Signal input to pin 11 (18) is rectified, algebraically converted and square-rooted. The square-rooted signal is filtered by the capacitor connected to pin 12 (17) to create a voltage that is proportional to the input signal's RMS value, which is then current-converted to become a CCA gain control signal.

2) CCA (CURRENT CONTROL AMP)

CCA is the amplifier which converts the degree of amplification, algebraically and linearly, as determined by the RMS LEVEL SENSOR's control signal. During the compression operation, for example, compression is linear with no relation to frequency band, thus a -60dB signal will be compressed to -30dB, a +10dB signal will be compressed to +5dB. (The process would be the exact opposite in the expansion operation).

CCA-A is the amplifier component and CCA-B is the buffer component.

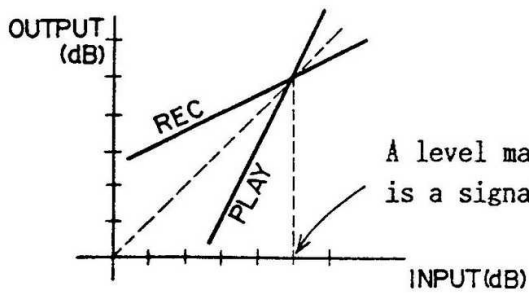

A level match (90mV at pins 2 and 27) which in this unit is a signal -6.5dB from the Dolby level.

3) RMS BPF and RMS PRE-EMPHASIS

The dbx's large rate of compression and expansion means that blooming will easily occur when input signals change rapidly. Inserting an RMS BPF and RMS PRE-EMPHASIS in the stage in front of the LEVEL SENSOR improves the blooming effect.

The RMS BPF eliminates the effects of tape hiss and head contact. The RMS PRE-EMPHASIS raises sensitivity in the high-frequency band to decrease the compression and expansion rate.

4) CR externally attached to pins 12, 17 and 19

The CR sets the rate of CCA gain reduction (rate of change in gain after the input signal rapidly disappears). The standard value is 125dB/s. Adjust the SFR so that the voltage across R11 (1K Ω) in the STOP mode.

5) LOGIC CONTROL

LOGIC CONTROL selects the switch in the IC as determined by the logic state at pins 15 and 16. If pin 15 is "Hi", dbx is on, if pin 15 is "Lo", dbx is off. When pin 16 is "Hi", the unit is in encode (record) state, when pin 16 is "Lo", the unit is in decode (playback) state.

EXPLODED VIEW-1

REF. NO.	PART NO.	DESCRIPTION
A	87-081-531-01	QTT+3-6
B	87-347-095-21	UT,+3-8 (B)
C	87-441-008-01	STE-2.5
D	87-321-097-21	QT,+3-1 2
E	87-081-785-01	VTT,+3-8
F	87-356-095-21	VT,+3-8 (R)
G	87-326-096-21	QT,+3-10 (R)
H	87-351-096-21	VT,+3-10
I	87-261-169-21	V+4-6
J	87-356-074-21	VT,+2.6-8 (R)
K	87-067-054-01	VTT+3-6 (R)
L	87-081-512-01	VTT+3-8
M	87-261-103-21	V+3-25

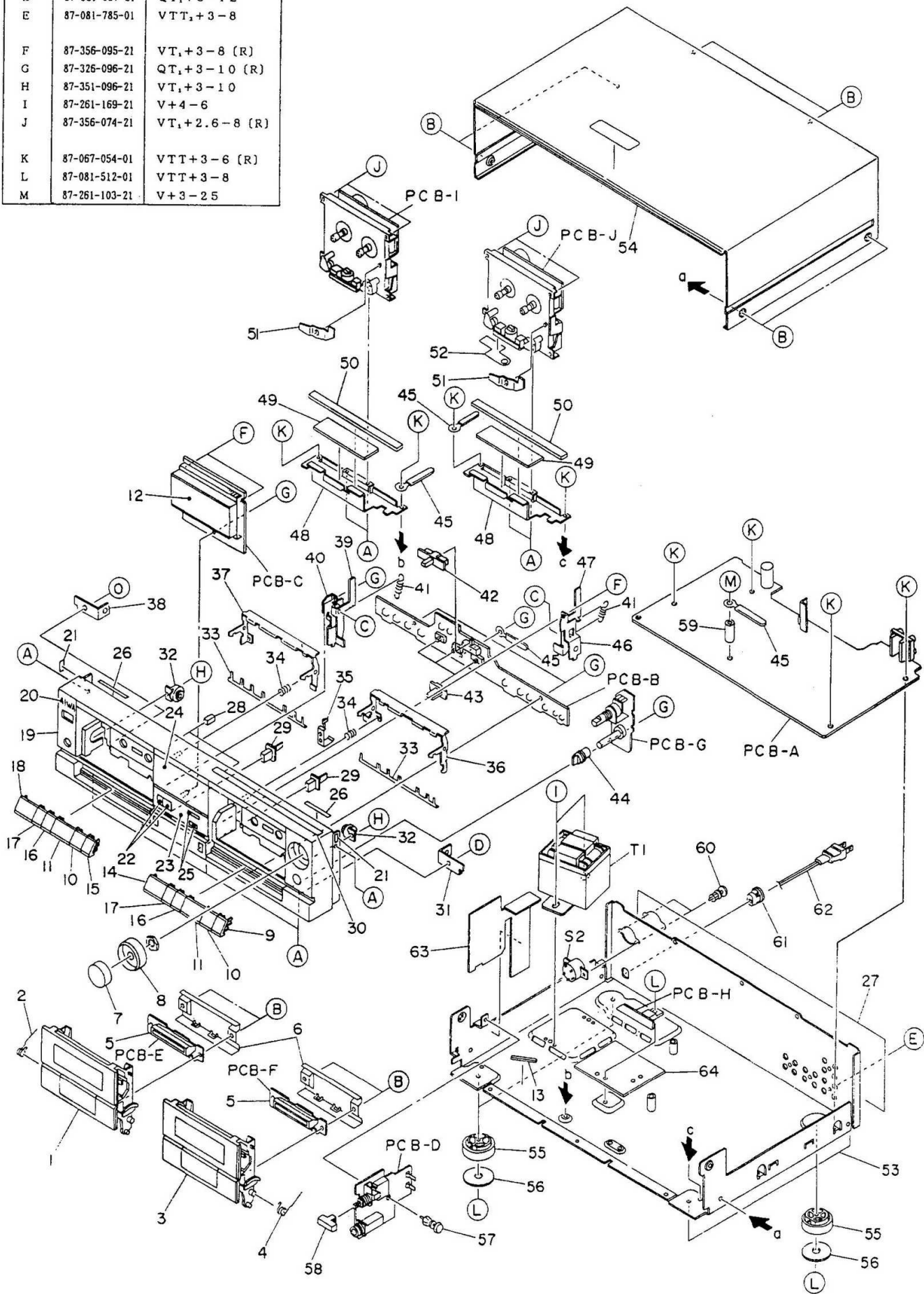

MECHANICAL PARTS LIST

PART NO. CHANGED TO	REF. NO.	PART NO.	ORDER	DESCRIPTION	COMMON MODEL	Q, TY
	1-1	09-047-284-010		CASSETTE BOX 1 ASSY(EXCEPT U)	*	1
	1-1	09-047-286-010		CASSETTE BOX 1 ASSY(U ONLY)	*	1
	1-2	*82-221-223-110		T-SPRING,EJECT 1	*	1
	1-3	09-047-285-010		CASSETTE BOX 2 ASSY(EXCEPT U)	*	1
	1-3	09-047-287-010		CASSETTE BOX 2 ASSY(U ONLY)	*	1
	1-4	*82-221-224-110		T-SPRING,EJECT 2	*	1
	1-5	*82-221-204-010		GUIDE,LED	*	2
	1-6	*82-221-033-010		PLATE,BOX REAR	*	2
	1-7	82-221-012-010		KNOB,VOLUME R	*	1
	1-8	82-221-011-010		KNOB,VOLUME L	*	1
	1-9	*82-221-039-010		PUSH-KEY ASSY,MUTE	*	1
	1-10	*82-221-038-010		PUSH-KEY ASSY,PAUSE	*	2
	1-11	*82-221-019-010		PUSH-KEY,STOP	*	2
	1-12	*82-221-035-010		SHHET,FL FILTER	*	1
	1-13	*82-785-273-010		CUSHION 35-5	*	1
	1-14	*82-221-017-010		PUSH-KEY,REC	*	1
	1-15	*82-221-024-010		PUSH-KEY,DUMMY B	*	1
	1-16	*82-221-020-010		PUSH-KEY,FF	*	2
	1-17	*82-221-018-010		PUSH-KEY,REW	*	2
	1-18	*82-221-023-010		PUSH-KEY,DUMMY A	*	1
	1-19	*82-221-002-110		CABINET,FRONT	*	1
	1-20	84-721-024-010		BADGE,AIWA	XC-001	1
	1-21	*81-544-235-010		SHEET 14-6-0.3	CS-W550	2
	1-22	*82-221-032-010		PUSH-KEY ASSY,DUBB	*	1
	1-23	*82-221-005-010		PANEL,CENTER	*	1
	1-24	*82-221-008-010		WINDOW,INDICATOR	*	1
	1-25	*82-221-028-010		PUSH-KEY,COUNTER RESET	*	1
	1-26	*82-221-232-010		FELT 4-30	*	2
	1-27	---		NAME PLATE, JACK	*	1
	1-28	*81-525-222-010		G CUSHION 6X3X2	HS-J300	2
	1-29	*82-221-029-010		PUSH-BUTTON,EJECT	*	2
	1-30	*82-174-045-110		BIAS EXPLANATION SHEET EX	*	1
	1-31	*82-221-209-010		HOLDER,C-BOX 2	*	1
	1-32	*87-063-143-010		OIL-DAMP 75	*	2
	1-33	*82-221-207-010		P-SPRING,PUSH-KEY	*	2
	1-34	*82-217-211-110		C-SPRING,LEVER EJECT	AD-WX909	2
	1-35	*82-221-206-010		EARTH PLATE,CENTER	*	1
	1-36	*82-221-222-010		PLATE,EJECT(3)-2	*	1
	1-37	*82-221-221-110		PLATE,EJECT(3)-1	*	1
	1-38	*82-221-208-010		HOLDER,C-BOX 1	*	1
	1-39	*82-221-210-010		LEVER,EJECT 1	*	1
	1-40	*82-221-216-010		HOLDER ASSY,EJECT 1	*	1
	1-41	*84-123-293-010		E-SPRING,M	*	2
	1-42	*82-221-014-010		KNOB,DOLBY	*	1
	1-43	*82-221-013-010		KNOB,REV MODE	*	3
	1-44	*84-424-008-010		KNOB,VOLUME	*	1
	1-45	---		WIRE BINDER	*	4
	1-46	*82-221-215-110		HOLDER ASSY,EJECT 2	*	1
	1-47	*82-221-211-010		LEVER,EJECT 2	*	1
	1-48	*82-221-214-010		HOLDER,MECHANISM	*	2
	1-49	*82-221-050-010		DAMPER,MECHANISM	*	2
	1-50	*82-217-248-010		DAMPER,MECHANISM 2	AD-WX909	2
	1-51	*82-217-213-110		LEVER,EJECT BLOCKING L	AD-WX909	2
	1-52	*82-221-229-010		PLATE,WIRE	*	1
	1-53	---		CHASSIS ASSY,AMP.	*	1
	1-54	*82-217-041-010		CABINET,STEEL	AD-WX909	1
	1-55	*81-715-051-010		FOOT 40	*	4
	1-56	*82-217-069-010		FELT ϕ 33.5	AD-WX909	4
	1-57	*87-084-086-010		NYLON RIVET 3.5-4.5	*	1
	1-58	84-721-023-010		PUSH-BUTTON,POWER	XC-001	1
	1-59	*82-221-230-010		COLLAR 18,LED	*	1
	1-60	*87-085-090-010		NYLON RIVET 3-6.5(H ONLY)	*	2
	1-61	*87-085-184-010		AC CORD BUSHING(H ONLY)	*	1
	1-61	*87-085-189-010		AC CORD BUSHING(U ONLY)	*	1
	1-61	*87-085-185-010		AC CORD BUSHING(E,K,Z ONLY)	*	1
	1-62	*87-034-732-010		AC CORD ASSY(H ONLY)	*	1
	1-62	*87-034-731-010		AC CORD ASSY(U,ONLY)	*	1
	1-62	*87-034-736-010		AC CORD ASSY(E,Z ONLY)	*	1
	1-62	*87-034-734-010		AC CORD ASSY(K, ONLY)	*	1
	1-63	*82-221-225-010		COVER,TERMINAL	*	1
	1-64	---		HEAT SINK	*	1

See the X-3 Mechanism (Supplement of Service Manual) for the exploded views.
The following parts have been changed for this model.

■ DECK 1 (X-3 P3)

ALTERATION PARTS LIST

PART NO. CHANGED TO	REF. NO.	PART NO.	ORDER	DESCRIPTION	COMMON MODEL	Q, TY
	1-20	*86-535-351-110		ACTUATING CHASSIS PH ASSY		1
	1-23	*86-535-356-010		HEAD HOUSING PH ASSY		1
	1-44	*86-535-353-010		FELT 5-4-2		1
	2-17	86-535-354-010		BELT		1

The following REF. NOS. are not used in this model.

1-4-1-6, 1-9, 2-9

ADDITIONAL PARTS LIST

PART NO. CHANGED TO	REF. NO.	PART NO.	ORDER	DESCRIPTION	COMMON MODEL	Q, TY
	1-45	*86-535-358-010		T-SPRING, BRAKE		1

■ DECK 2 (X-3 R3)

ALTERATION PARTS LIST

PART NO. CHANGED TO	REF. NO.	PART NO.	ORDER	DESCRIPT	MON EL	Q, TY
	1-20	*86-535-351-110		ACTUATING CHASSIS PH ASSY		1
	1-23	*86-535-356-010		HEAD HOUSING PH ASSY		1
	1-44	*86-535-353-010		FELT 5-4-2		1
	2-17	86-535-354-010		BELT		1

The following REF. NOS. are not used in this model.

1-4, 2-9

ADDITIONAL PARTS LIST

PART NO. CHANGED TO	REF. NO.	PART NO.	ORDER	DESCRIPTION	COMMON MODEL	Q, TY
	1-45	*86-535-358-010		T-SPRING, BRAKE R		1

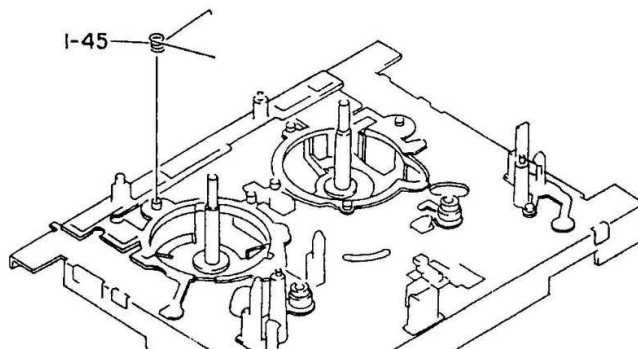

■ ACCESSORIES/PACKAGE LIST

PART NO. CHANGED TO	REF. NO.	PART NO.	ORDER	DESCRIPTION	COMMON MODEL	Q, TY
	1	*82-221-901-010		INSTRUCTION BOOKLET	*	1
	2	*87-032-845-010		SIEMENS PLUG (H ONLY)		1