

Accuphase

DUAL CHANNEL POWER AMPLIFIER

PRO-5

- 9-Parallel Push-Pull Output Stage ■ Low-Impedance Setting
- Front-Intake and Rear-Exhaust Forced-Air Cooling System for Overheat Protection
- 1,200W (at 4 ohms) Monophonic Operation

© beim Hersteller
Archiv Michael Otto
HiFi-Classic.de



Professional Series

All stages push-pull configuration. 9-parallel push-pull power stages guarantee stereo using the low impedance setting, even an extremely low impedance speaker of 2 ohms

The output transistors, the main source of heat in the amplifier, are mounted on a large, square conduit type heat sink and are cooled by a fan mounted on the rear panel by forcibly drawing cool air from the intake louvers on the front panel. The photograph below shows one channel amp unit.

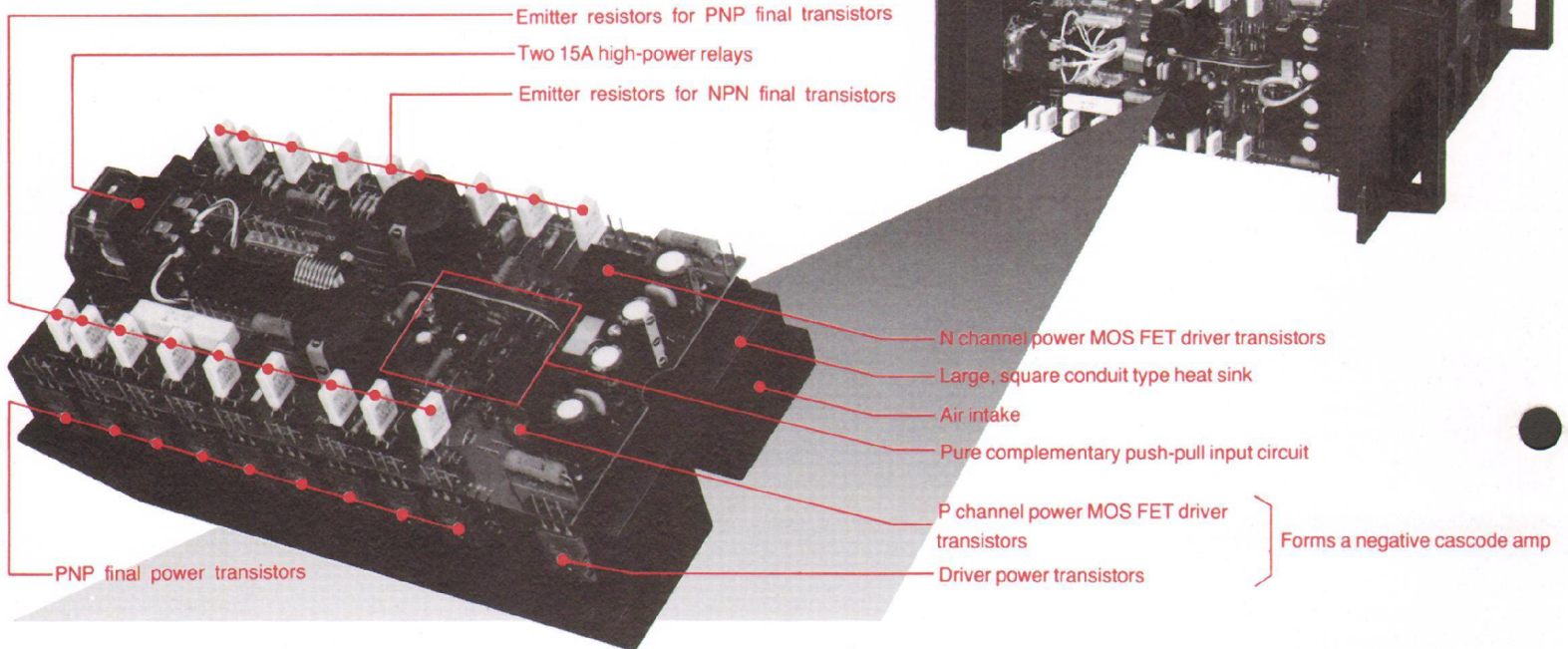

The Accuphase PRO series amplifiers have been made up by pursuing the highest reliability and durability required for professional amps. This was achieved by drawing on Accuphase development technologies for high-class audio amps as accumulated over the years to cater to fastidious audiophiles.

The first product exclusively for professional use from Accuphase, the PRO-5 is a 2-channel power amp with the rated output of 250 W/ch at 8 ohms (20 to 20,000 Hz), 600 W/ch at 2 ohms (20 to 20,000 Hz), and will occupy the center stage of professional audio equipment. It can also be used as a monophonic power amp of 1,200W at 4 ohms by setting the OPERATION selector switch to the MONO position.

To improve reliability and durability, first, the powerful output stage was designed to assure the maximum current capacity possible. To guarantee such high power output, it has a total of 18 bipolar power transistors per channel, each of which has a maximum power dissipation (Pc) of 150W, that form a 9-parallel push-pull output circuitry with a total electrical capacity of 2,700W.

These elements are mounted on a large, square conduit type heat sink to effectively cool them by using a forced-air cooling system. The air is drawn into the PRO-5 through the intake louvers on the front panel and expelled through the exhaust on the rear. Therefore, the PRO-5 will function normally even in a carrying case or other confined space where the upper/lower and side panels are tightly sealed. If the temperature of the heat sink exceeds the predetermined value, the top three elements of each output meter will light continuously to warn of the overheated condition.

The amplifier circuit is configured entirely of parallel push-pull circuits from the input to the output stages, which Accuphase has traditionally adopted. The sound quality of the PRO-5 was also improved to obtain a sound with excellent transparency which is a major requisite of professional power amps. We are convinced that the PRO-5 can fully satisfy the high quality sound requirements of professional use.

POWERFUL OUTPUT STAGE ASSURES STEREO = 600 W/ch (2 ohms) AND MONOPHONIC = 1,200W (4 ohms)

Fig. 1 shows the PRO-5 circuit diagram. The output stage has a total of 18 bipolar transistors per channel, each with a maximum power dissipation (Pc) of 150W. These form a 9-parallel push-pull output circuitry that has a total electrical capacity of 2,700W. The purpose of this powerful output stage is to supply a sufficient power even into low-impedance loads as well as to have improved durability even in the event of speaker wiring shorts.

The powerful output stage guarantees the rated output values of 250 W/ch at 8 ohms, 420 W/ch at 4 ohms, and 600 W/ch at 2 ohms. The PRO-5 can also be used as a monophonic power amp of 1,200W at 4 ohms by setting the OPERATION selector switch on the rear panel to the MONO position.

A LARGE, SQUARE CONDUIT TYPE HEAT SINK CONSTRUCTION AND FRONT-INTAKE AND REAR-EXHAUST FORCED-AIR COOLING SYSTEM PERFECTLY PROTECT THE UNIT AGAINST OVERHEATING.

In the PRO-5, the output transistors, the main source of the heat in the amp are mounted on a large, flow-through type heat sink and the air within this heat sink is forcibly expelled. The cool

air is drawn through the intake louvers on the front panel, passed through the heat sink, and expelled through the exhaust at the rear by using a cooling fan mounted on the rear panel. Some of the air forced through the amp at this time also passes the electrolytic capacitors and power transformer with a cooling effect. For this reason, the PRO-5 will function normally even in a carrying case or other confined space where the upper/lower and side panels are tightly sealed. The intake louvers can be easily dismounted for cleaning or replacement.

CURRENT LIMITER TYPE PROTECTION CIRCUIT AND OVERHEAT INDICATORS ENSURE TROUBLE-FREE OPERATION.

The protection circuit of the PRO-5 uses a current limiter. This method, while providing superior power supply capabilities into low-impedance loads compared to the ASO detection method, requires considerable reserves from the output stage. Fortunately, the Pc values of the PRO-5 are more than adequate and we have been able to adopt this method for excellent protection of the transistors in the event of speaker wiring shorts as well as to guarantee powerful output of 600 W/ch at 2-ohm load. The maximum permissible current for the PRO-5 is 27A. The limiter comes into operation if a current that exceeds this value is detected. Also when the limiter has operated continuously for a period of

time, the internal circuit breaker operates to isolate the power supply and protect the transistors. If the temperature of the heat sink exceeds 100°C, the top three elements of the LED output meter will light continuously to warn of the overheated condition.

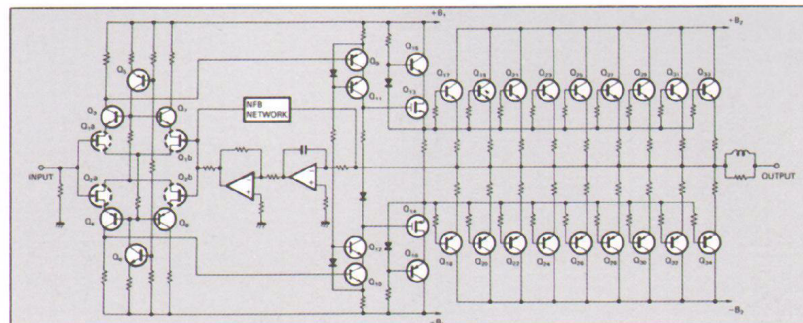

Fig. 1 PRO-5 Circuit Diagram

250 W/ch (8 ohms), monophonic=840W (8 ohms). By (stereo=600 W/ch) can be fully driven.

Accuphase **PRO-5**



HIGH-QUALITY SOUND REALIZED BY ALL PUSH-PULL STAGES

As shown in Fig. 1, the amplifier circuit is configured entirely of complementary-symmetrical push-pull circuits, from the input to the output stages.

Having employed this circuit configuration for more than a decade for professional audiophile equipment, Accuphase is well acquainted with its design technique and can confidently say that it is an ideal one for amplifiers. A stable NFB can be applied to the circuit, ensuring consistent operation even under the extreme load conditions required of a professional power amplifier.



1,200W (AT 4 OHMS) MONOPHONIC OPERATION

The MONO (bridge connection) position of the OPERATION selector switch enables the PRO-5 to function as a powerful monophonic amp. When the bridge connection is selected, the load as seen from the amp increases; the minimum load impedance becomes twice that when two channels are used. Since the minimum load impedance for two-channel operation is guaranteed at 2 ohms, complete drive of 4-ohm monophonic loads is assured. The rated output at this time is 1,200W (20 to 20,000Hz, distortion 0.02%).



TWO PAIRS OF BALANCED/UNBALANCED INPUT TERMINALS; 2-POLE BANANA JACKS OR OPTIONAL XLR CONNECTORS FOR OUTPUT TERMINALS

Phone jacks provide unbalanced input (parallel connection) for each channel. For the balanced inputs there are two XLR-type connections (XLR-3-31 and XLR-3-32) available for each channel. The polarity of the XLR-type connectors are (1) ground, (2) hot, and (3) cold.

The standard output terminal is a two-pole banana jack. Connection of an XLR-type connector is possible by replacing the mounting board with an optional conversion board.



1dB STEP INPUT LEVEL CONTROLS

The PRO-5 is provided with 1dB-step input level control within a range from 0 to -20dB for each channel, assuring accurate level controls. The control knobs, being recessed in the molded frame, do not protrude from the front panel and thus discourage accidental rotation.



10-SEGMENT LED OUTPUT METERS

Bar-graph indication type output meters with LEDs are adopted for the PRO-5 for the sake of increased durability. Each output meter has 10 segments. Two scales are provided on the output meters: one in dBs and the other in watts at 8 ohms.

GUARANTY SPECIFICATIONS

PERFORMANCE GUARANTY

All Accuphase product specifications are guaranteed as stated.

Rated output (20 to 20,000Hz, distortion: 0.02%)

Stereophonic operation (both channels driven)
 600W/ch 2-ohm load
 420W/ch 4-ohm load
 250W/ch 8-ohm load
 125W/ch 16-ohm load

Monophonic operation (bridge connection)
 1,200W 4-ohm load
 840W 8-ohm load
 500W 16-ohm load

Total harmonic distortion

Stereophonic operation (both channels driven)
 0.02% 2-ohm load
 0.01% 4- to 16-ohm load
 Monophonic operation (bridge connection)
 0.02% 4-ohm load
 0.01% 8- to 16-ohm load

IM distortion (SMPTE-IM)

0.003%

Frequency response

20 to 20,000Hz +0, -0.2dB (Rated output, input attenuator at MAX)
 0.5 to 150,000Hz +0, -3.0dB (1W output, input attenuator at MAX)
 0.5 to 120,000Hz +0, -3.0dB (1W output, input attenuator at -6dB)

Gain

31.2dB Stereophonic operation
 37.2dB Monophonic operation

Load impedance

2 to 16 ohms Stereophonic operation
 4 to 16 ohms Monophonic operation

Damping factor (8-ohm load at 50Hz)

200 Stereophonic operation
 100 Monophonic operation

Input sensitivity (8-ohm load)

0.775V 100W output (stereophonic operation)
 0.388V 100W output (monophonic operation)
 1.23V Rated output (stereo/monophonic operation)

Input impedance

20k ohms Unbalanced input
 40k ohms Balanced input

S/N ratio (A-weighted, input shorted)

115dB Rated output

Output meters

LED display 8-ohm load, 125W = 0 dB
 -22, -17, -12, -9, -6,
 -4, -2, 0, +2, +4 dB

Input attenuator

0 to -20 dB in 1 dB steps, -∞

Input terminals

Phone jacks Two terminals each for Channels A and B
 XLR (cannon) connectors XLR-3-31 and XLR-3-32 for Channels A and B
 Pins: 1 Ground, 2 Hot, 3 Cold

Output terminals

Two-pole banana jacks
 Can be adapted for XLR-type or phone jacks by installing optional board

Cooling method

Forced-air cooling method (front panel air intake louvers, rear panel exhaust)
 Two-speed cooling fan (automatically operates at high speed when temperature over 80°C detected in heat sink)

Semiconductors

72 transistors, 8 FETs, 6 ICs, 86 diodes

Power requirements and consumption

100V, 117V, 220V, 240V, 50/60Hz
 145W no signal
 840W at rated output into 8-ohm load

Dimensions and weight

482.5mm (19 inches) × 190.5mm (7-1/2 inches) (Max. height) × 381mm (15 inches) (D)
 Refer to dimensioned diagram
 Panel height Four units
 Panel size 482.5(W) × 176.5(H) mm
 Rack mounting Can be mounted in standard 19-inch rack
 Weight 27.3kg (60 lb) net, 32.5kg (71 lb) in shipping carton

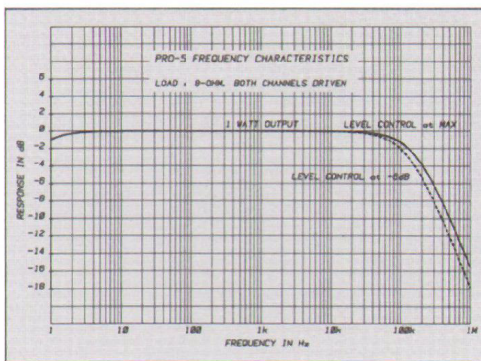

Frequency Characteristics
 Load: 8 ohms, Both channels driven

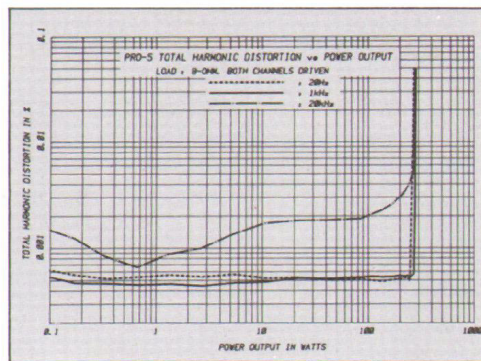

Total Harmonic distortion vs. Power Output
 Load: 8 ohms, Both channels driven

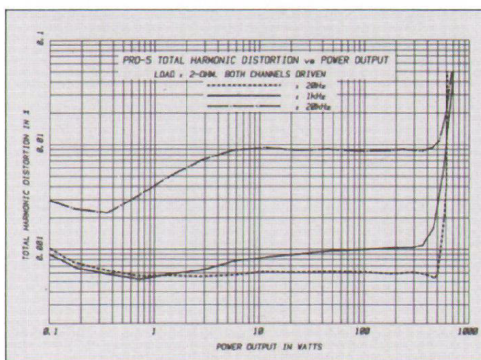

Total Harmonic distortion vs. Power Output
 Load: 2 ohms, Both channels driven

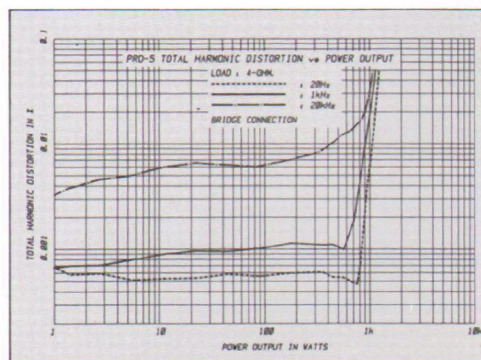

Total Harmonic distortion vs. Power Output
 Load: 4 ohms

Accuphase PRO-5

Panel control

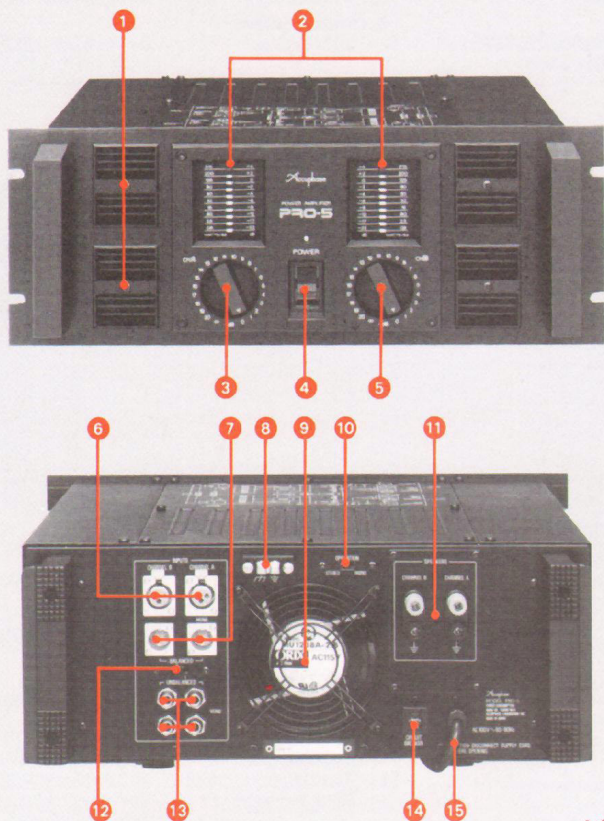

- 1 Cool air intake louvers
- 2 LED output meters (If the temperature of the heat sink exceeds 100°C, the top three (red) LEDs will light continuously to warn of the overheated condition.)
- 3 Input attenuator knob for Channel A (Use this during monophonic operation.)
- 4 POWER switch
- 5 Input attenuator knob for Channel B
- 6 XLR-type receptacle (XLR-3-31 matchable with XLR-3-12C)
- 7 XLR-type plug receptacle (XLR-3-32 matchable with XLR-3-11C)
- 8 Ground terminal board (Ground line select)
- 9 Cooling fan
- 10 OPERATION selector switch (STEREO/MONO)
- 11 Speaker output terminals; two-pole banana jacks as standard. Phone jacks or XLR-type connectors available by installing an optional board
- 12 Balanced/unbalanced selector switch
- 13 Standard phone jacks (unbalanced input terminals)
- 14 Circuit breaker
- 15 AC power cord

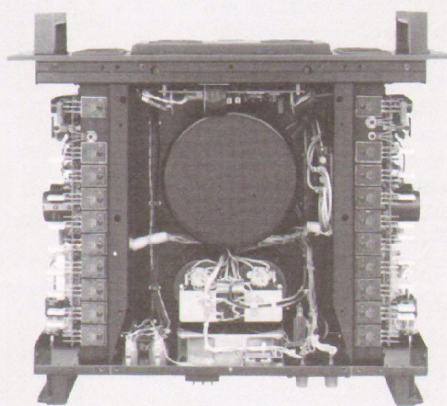

■ Simple internal layout

© beim Hersteller
Archiv Michael Otto
HiFi-Classic.de

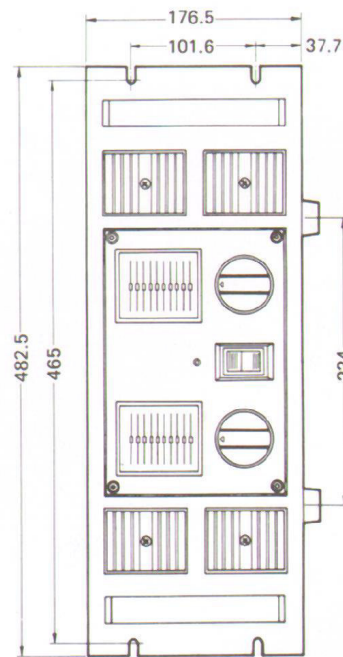
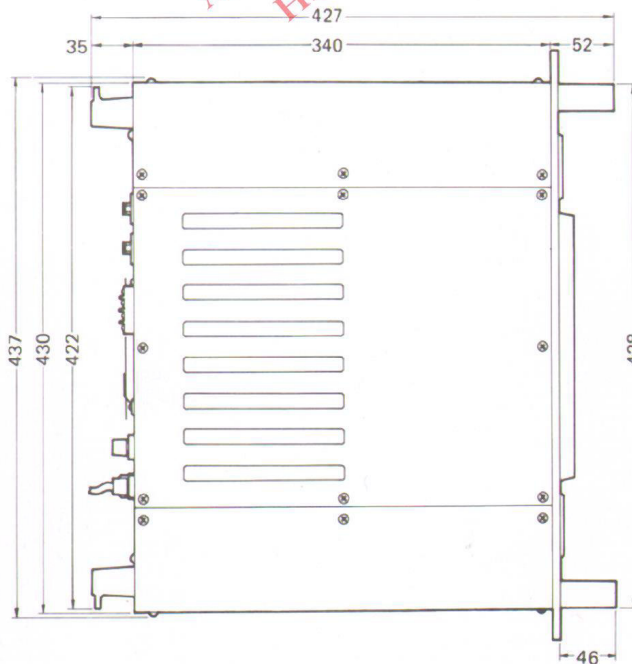
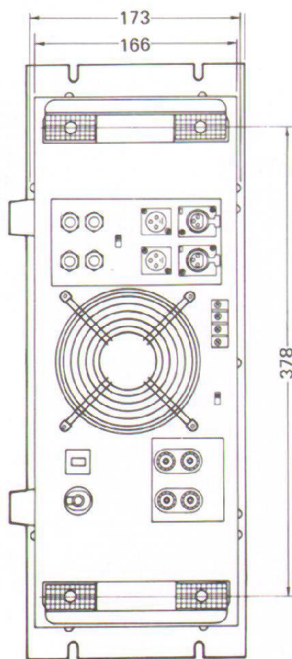

Unit: mm

Accuphase
ACCUPHASE LABORATORY INC.