

Accuphase

FREQUENCY DIVIDING NETWORK

PRO-F50

- Twin-mono construction for Bi-amplification to Quadri-amplification stereo output
- 24 crossover frequencies, selectable in 1/3-octave steps

© beim Hersteller
Archiv Michael Otto
HiFi-Classic.de

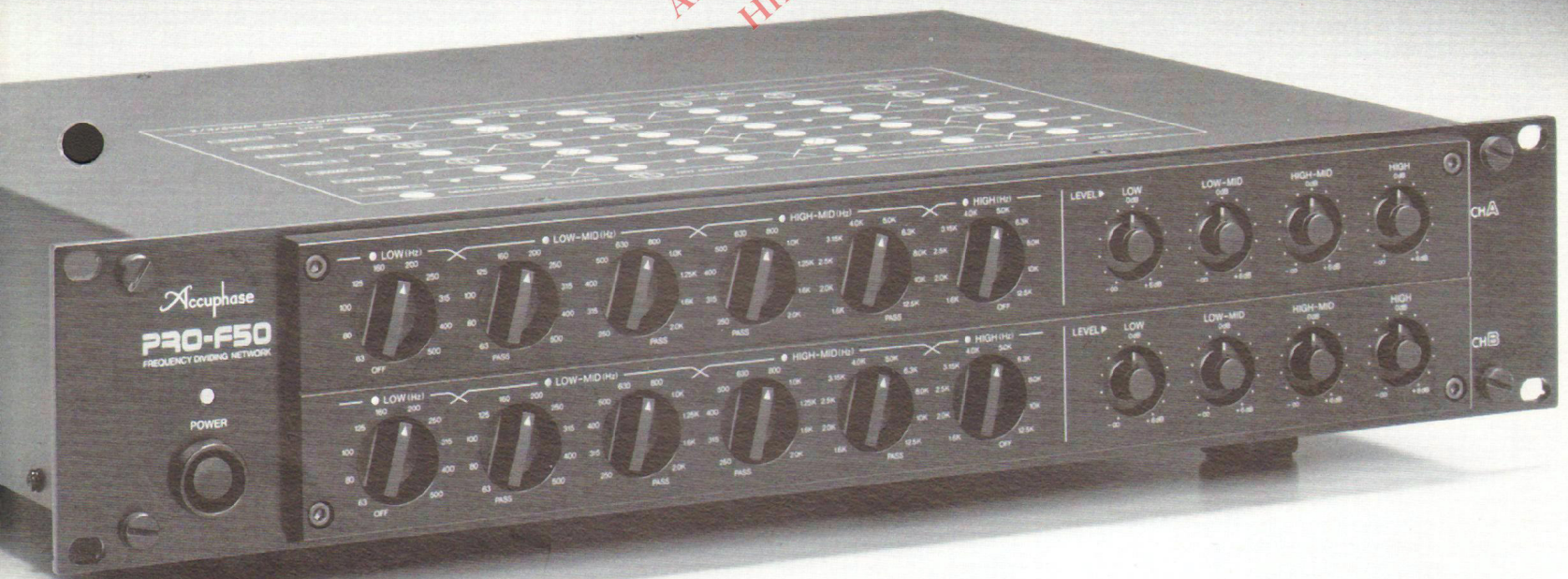

Professional Series

24 crossover frequencies in 1/3-octave steps for unlimited versatility. Stereo Instant configuration for Bi-, Tri-, or Quadri-amplification system. GIC Butterworth

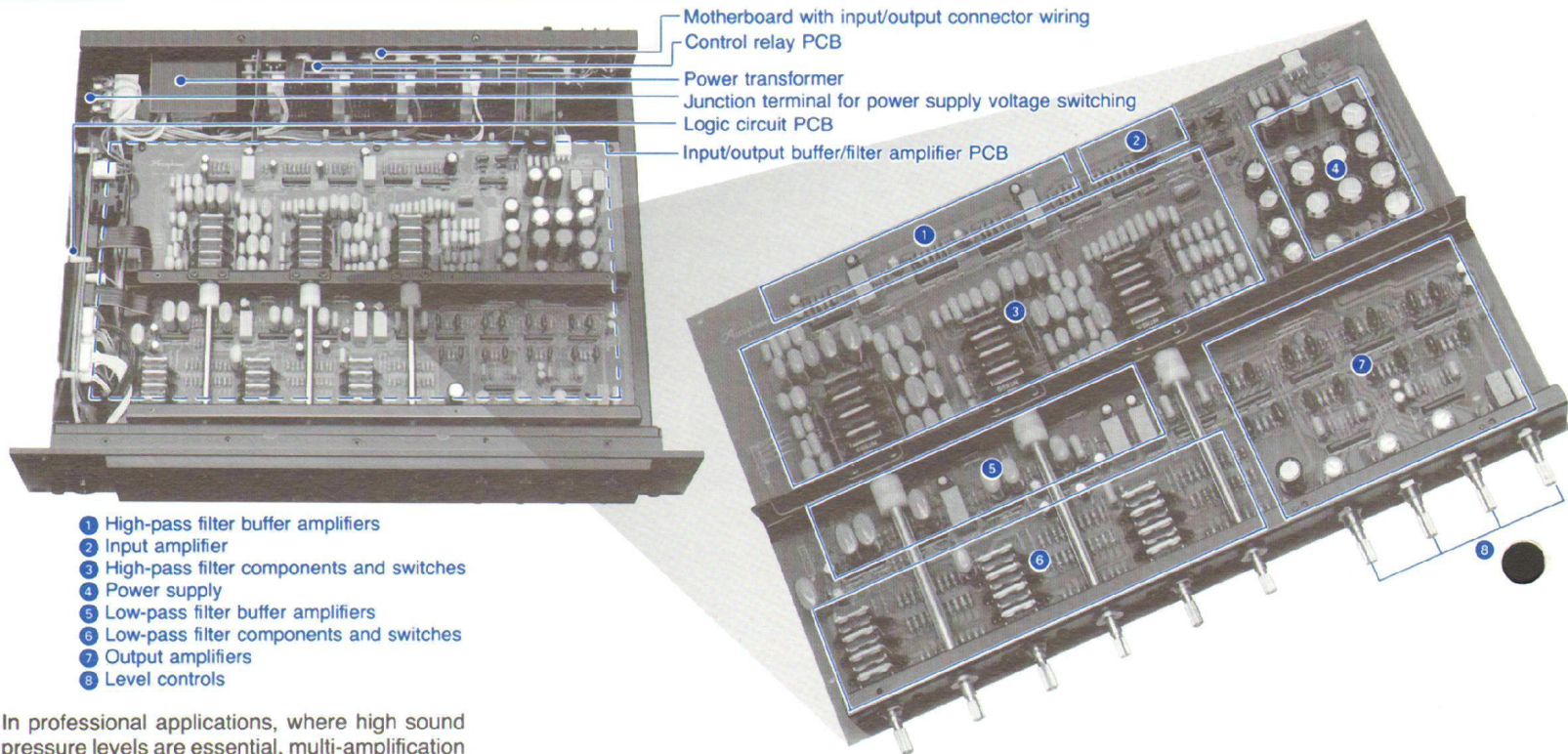

- 1 High-pass filter buffer amplifiers
- 2 Input amplifier
- 3 High-pass filter components and switches
- 4 Power supply
- 5 Low-pass filter buffer amplifiers
- 6 Low-pass filter components and switches
- 7 Output amplifiers
- 8 Level controls

In professional applications, where high sound pressure levels are essential, multi-amplification is an extremely promising approach. Especially when sound quality is critical, driving each unit with its own amplifier is an absolute prerequisite for satisfying results.

The Accuphase Professional Series amplifiers PRO-5 (250 watts per channel) and PRO-2 (100 watts per channel) are renowned both for outstanding sound quality and unsurpassed reliability. The newly-developed frequency dividing network PRO-F50 ideally complements these products to create a versatile multi-amplifier configuration. Accuphase has gained extensive technological know-how through the development of superb audio amplifiers, and this experience is fully reflected in the PRO-F50. Superior sound quality is the hallmark of this product, coupled with outstanding reliability and flawless performance.

The PRO-F50 accommodates Bi-amplification to Quadri-amplification systems. Crossover frequencies can be selected in 1/3-octave steps, offering a choice of 24 crossover points between 63 and 12,500 Hz. The use of multiple-contact switches ensures versatility and swift and easy operation. To compensate for overall gain losses, the PRO-F50 has separate level controls for each channel which provide up to 6 dB gain. This permits precise level balancing. The phase of each channel can also be switch-controlled, with LED indicators showing polarity. A separate subwoofer switch mixes the left and right channel signals for dynamic low-end reproduction in a 3-D system.

The filter circuits employ latest GIC technology to achieve superb reproduction quality. All circuit components have been strictly selected to meet the highest criteria. The twin-mono construction with separate power supplies effectively eliminates interchannel crosstalk. The result of these uncompromising efforts is utterly natural and transparent sound reproduction.

The Frequency Dividing Network PRO-F50 not only offers truly great sound. Its array of versatile features also makes it ideally suited to carry out precise and delicate adjustments in even the most demanding professional environment, bringing out the utmost in quality from the speakers.

Stereo configuration with Bi-amplification to Quadri-amplification output 24 crossover frequencies from 63 to 12,500 Hz in 1/3-octave steps 18 dB/oct slope filter characteristic



The unit is configured for stereo operation, with switch selection for Bi-amplification, Tri-amplification, or Quadri-amplification system. Being able to make precise and swift adjustments of crossover frequency, phase, and level balance is a must for truly professional applications. The PRO-F50 fulfills all of these requirements perfectly. As can be seen from the table, the PRO-F50 offers the astonishing number of 24 different crossover points. Corresponding to ISO specifications, the frequencies are spaced by one-third of an octave and cover the range from 63 to 12,500 Hz. Such versatility was unattainable with previous units. Frequency precision is guaranteed to $\pm 3\%$, and the cutoff slope is -18 dB, for ideal attenuation characteristics.



Silver-clad multi-slider switches assure outstanding long-term reliability

The crossover selector switches must withstand numberless switching operations without any deterioration in performance. The PRO-F50 shines also in this respect. It employs newly developed silver-clad switches with multiple slider contacts. This has the same effect as using several parallel circuits. The sealed construction is another important factor which contributes to extremely long contact life.



GIC Butterworth filters ensure superior sound quality

The circuit topology of the filter section has a decisive impact on overall sound quality. In the PRO-F50, the so-called GIC (Generalized Impedance Converter) principle is used. The

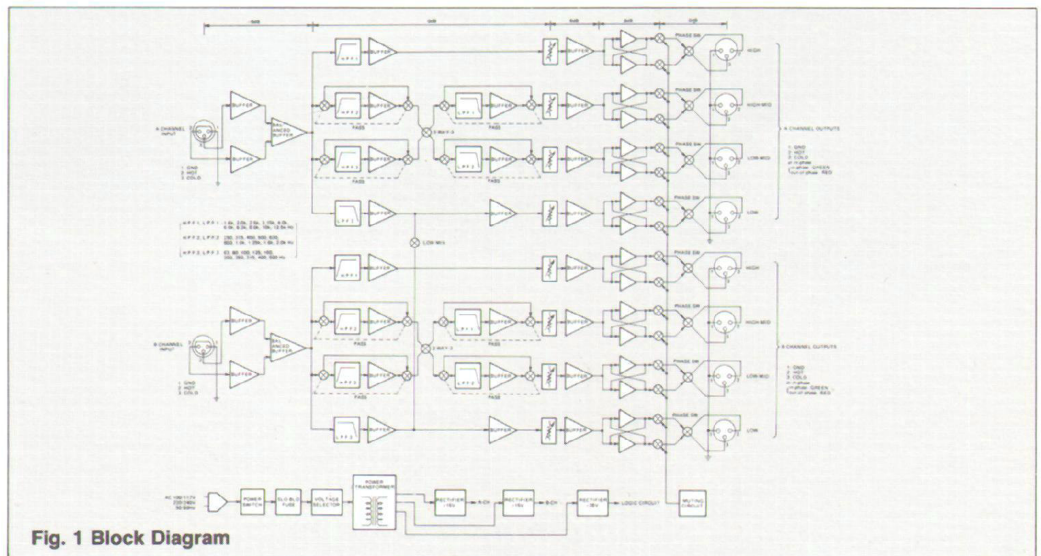

Fig. 1 Block Diagram

Unit in twin-mono construction.
 Crossover filters ensure superior sound quality.

Accuphase **PRO-F50**

Crossover frequencies of the PRO-F50

Crossover frequency (Hz)	Bi-amplification system			Tri-amplification system						Quadri-amplification system		
	I	II	III	I		II		III		LOW/LOW-MID	MID-LOW/HIGH-MID	HIGH-MID/HIGH
				LOW/MID	MID/HIGH	LOW/MID	MID/HIGH	LOW/MID	MID/HIGH			
63	⊙											
84	⊙											
100	⊙											
125	⊙											
160	⊙											
200	⊙											
250	⊙	⊙										
315	⊙	⊙										
400	⊙	⊙										
500	⊙	⊙										
630	⊙	⊙										
800	⊙	⊙										
1,000	⊙	⊙										
1,125	⊙	⊙										
1,600	⊙	⊙										
2,000	⊙	⊙										
2,500	⊙	⊙										
3,150	⊙	⊙										
4,000	⊙	⊙										
5,000	⊙	⊙										
6,300	⊙	⊙										
8,000	⊙	⊙										
10,000	⊙	⊙										
12,500	⊙	⊙										

PRO-F50 Guaranteed Specifications

- Type**
Bi- to Quadri-amplification system stereo electronic crossover system
- Crossover frequencies (see table)**
24 points (from 63 to 12,500 Hz) based on ISO 1/3-octave frequency selectable by rotary switch
- Crossover point characteristic**
-3.0 dB ±3%
- Attenuation slope characteristic**
-18 dB/oct
- Filter type**
GIC Butterworth type
- Gain**
-∞ to +6 dB, continuously changable in each band
- Input impedance**
40k ohms, balanced, XLR type
- Output impedance**
100 ohms balanced, XLR type
- Maximum output level**
+24 dBm (0.002% of distortion from 20 to 20,000 Hz)
- Load impedance**
600 ohms min.
- Frequency response**
+0, -0.2 dB from 20 to 20,000 Hz
+0, -3.0 dB from 1.0 to 100,000 Hz (load impedance: 40k ohms)
+0, -3.0 dB from 6.0 to 100,000 Hz (load impedance: 600 ohms)
- Total harmonic distortion (from 20 to 20,000 Hz)**
0.002% at maximum output level
- S/N (A-weighted, input shorted)**
105 dB (input level: +4 dBm)
- Phase selection switch**
Selectable in each band by the rear panel switch indicated by LEDs in the front panel
- Subwoofer system**
Possible to change the low-range band to "MONO" by the rear panel switch
- Semiconductors**
12 Tr's, 12 FETs, 46 ICs, 34 Di's
- Power requirements**
Voltage selection by rewiring for 100/120V and 220/240V, 50/60 Hz operation
- Dimensions**
width 482.5 mm (19 inches), height 107 mm (4-1/4 inches), depth 353 mm (13-15/16 inches) (see Dimensional drawing)
Panel height: 2U
Panel size: width 482.5 mm (19 inches), height 88 mm (3-1/2 inches)
Rack mount: possible to mount to 19 inches standard rack
Weight: 10.2 kg (22.4 lbs)

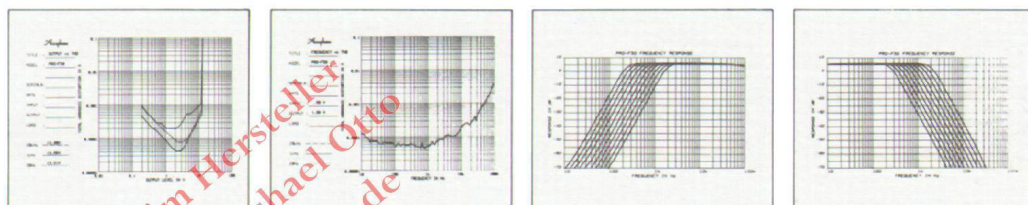

circuit configuration for the high-pass and low-pass filters is shown in Figs. 2 and 3. In conventional active filters with feedback loops, the signal has to pass through an R/C network and the entire amplifier stage, which tends to impair sound quality. With the GIC circuit principle, the signal passes through a resistor or capacitor, but the active components are routed to ground, connected in parallel, which reduces their effect on sound quality. A further advantage of this approach is the fact that frequency precision is not influenced by component tolerances. The GIC principle has another desirable effect. As can be seen from the frequency response charts, it shows no rise outside its bandpass.

Ordinary filters suffer from a certain backlash, as their response rises again after a certain degree of attenuation has been achieved. The GIC filter on the other hand maintains ideal attenuation characteristics right down into the residual noise level, which contributes to sound purity. Because of this superior performance, the GIC principle is also used for demanding high-order filters in CD players.

Independent twin-mono construction eliminates interchannel interference

The elimination of crosstalk between channels A and B is especially important in a professional audio system, as completely different signals may be routed through the two channels. In the PRO-F50, the two sections are powered from separate transformer windings with discrete filtering and smoothing circuits. The circuit boards of the filter itself are also completely physically separate. Thanks to this thorough approach, interchannel interference is reduced to an absolute minimum, as exemplified by the amazing crosstalk specification of -80 dB or less (20 - 20,000 Hz).

Level controls with maximum 6 dB gain

Separate level controls permit accurate, continuous adjustment of the level in each band. The maximum gain relative to the input signal is 6 dB, which is especially useful to compensate for low input levels.

Independent phase switches and indicators for each band

A truly professional frequency divider must provide a means to compensate for the phase requirements of different driver units and to align the overall phase relationship of a system. The PRO-F50 gives total control over this aspect also, as it provides separate phase inverter switches for each band. The color of an LED indicator for each band shows the relative phase setting vs. the input signal.

Subwoofer switch

Reproducing the extremely low frequencies with one large woofer driven by a monophonic signal is an effective way to cope with space limitations. The low-range band of the PRO-F50 provides a subwoofer switch that combines the A and B channel signals into one output, for easy setup of a subwoofer system.

Optional acrylic panel

If the unit is to be used with fixed frequency and level settings for an extended period, the front panel can be covered with the optional acrylic panel (B-2), to prevent accidental resetting of switches.

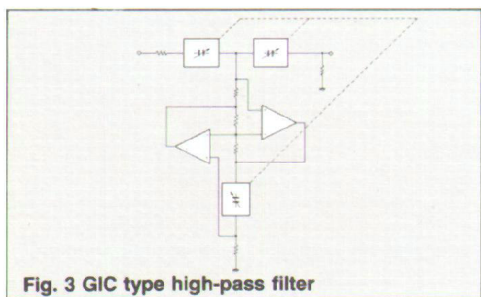
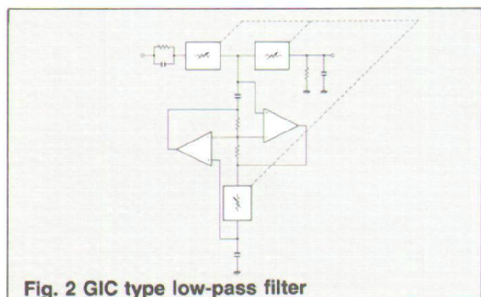

Accuphase PRO-F50

Panel Front

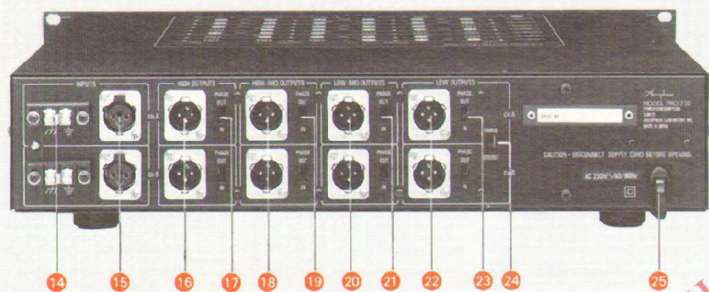
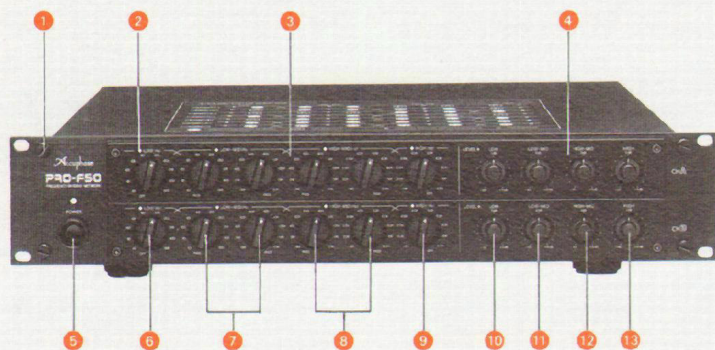

- 1 These four screws must be removed to mount the optional acrylic panel.
- 2 **Band and phase indicators** (lighted LED shows band in use; green: regular phase, red: inverted phase)
- 3 **Crossover selector switches for channel A** (lower row serves channel B)
- 4 **Level controls for channel A** (lower row serves channel B)
- 5 **Power switch**
- 6 **LOW range crossover frequency selectors**
- 7 **LOW-MID range crossover frequency selectors**
- 8 **HIGH-MID range crossover frequency selectors**
- 9 **HIGH range crossover frequency selectors**
- 10 **LOW range level controls**
- 11 **LOW-MID range level controls**
- 12 **HIGH-MID range level controls**
- 13 **HIGH range level controls**
- 14 **Ground terminals** (ground line selection)
- 15 **Input connectors** (corresponding to XLR-3-31/XLR-3-12C)
- 16 **HIGH range output connectors** (corresponding to XLR-3-32/XLR-3-11C)
- 17 **HIGH range phase selector switches**
- 18 **HIGH-MID range output connectors**
- 19 **HIGH-MID range phase selector switches**
- 20 **LOW-MID range output connectors**
- 21 **LOW-MID range phase selector switches**
- 22 **LOW range output connectors**
- 23 **LOW range phase selector switches**
- 24 **LOW range mono switch**
- 25 **Power cord**

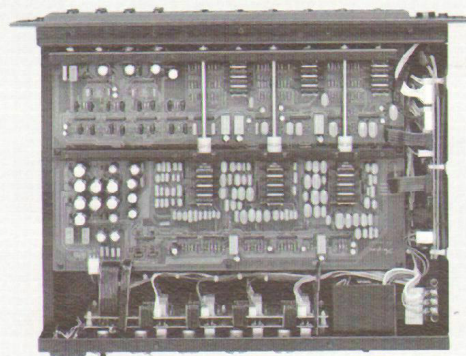

■ Neat internal layout

© beim Hersteller
Archiv Michael Otto
HiFi-Classic.de

Dimensional drawing

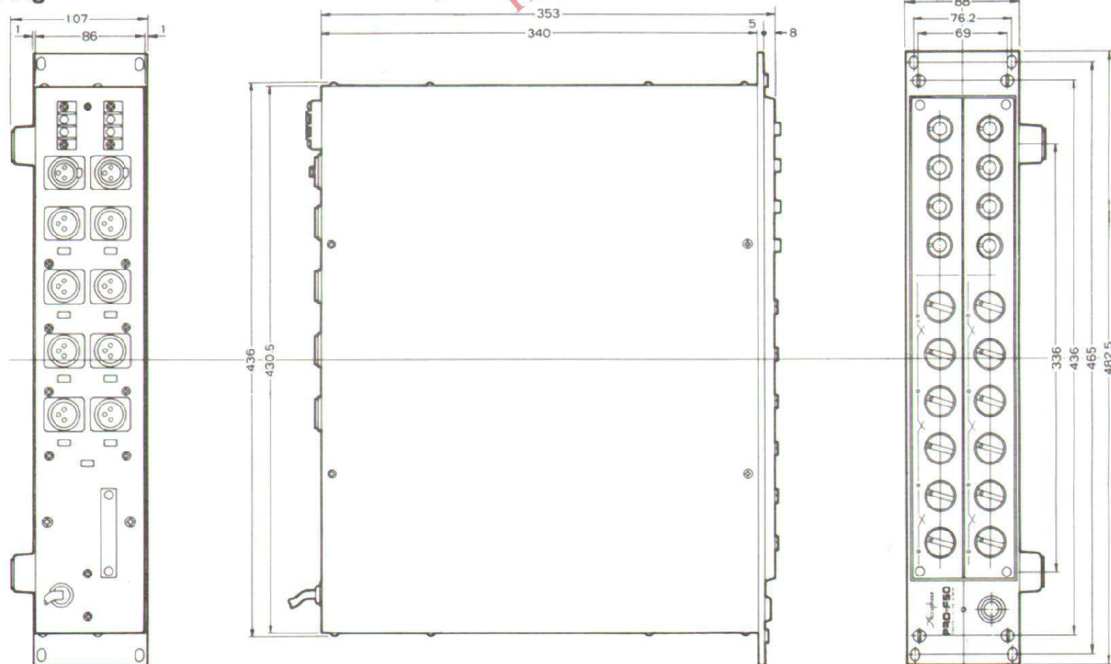

Unit: mm

