

Accuphase

STEREO POWER AMPLIFIER

P-266

- MOS FET triple push-pull output stage
- DC servo-controlled circuit
- Built-in bridging connection circuit.

© beim Hersteller
Archiv Michael Otto
HiFi-Classic.de



Normal operation 130W/ch (at 8 ohms) and Class-A operation High-power monophonic power amplification using bridging connection realized with MOS FET triple push-pull output stage

Employing the most ideal power amplification MOS FET devices in a triple push-pull output stage, the P-266 is one of the latest products perfected with Accuphase's long-standing superior design technology.

A main feature is its four-way operational control versatility which enables the P-266 to be used for diverse power amplifier applications, namely, as: (1) a 130 W/ch stereo power amplifier when operated normally; (2) a 30 W/ch pure Class-A operated stereophonic power amplifier; (3) an extra powerful 400 W monophonic power amplifier when its built-in bridging connection circuitry is used, and (4) a 110 W pure Class-A operated monophonic power amplifier. All the above power output ratings apply to 8-ohm loads, with distortion held to within an infinitesimal 0.01% from 20 to 20,000 Hz. Furthermore, all the above operational modes are achieved perfectly without any compromise.

Another important feature of the P-266 is that all its push-pull amplifier stages are directly coupled, thanks to its excellently designed DC Servo Control system. Moreover, a cascode push-pull pre-driver stage and MOS FETs in the final output stage endow it with almost ideal linearity and excellent high frequency performance.

The elegant, refined sound quality of MOS FETs and pure Class-A operation also make it a most suitable power amplifier choice for multi-amplification systems which seek the ultimate in sound quality. Furthermore, its built-in bridging connection system permits a greatly increased power output capability for special requirements, and ranks the P-266 above any comparable power amplifier on the market.

When low impedance speaker loads are involved. Ordinarily, protection circuits are provided to restrict such currents by controlling load impedance levels, which, of course, greatly reduces the power output capability of such amplifiers.

The use of 4-ohm rated speakers does not always mean that the load is always 4 ohms. In practice, the impedance may vary down to 3 ohms or 2 ohms depending on the signal frequency.

Furthermore, counter-electromotive forces can cause momentary transient signals that are likely to lower the impedance still further.

It is to counter such conditions that the P-266 is designed with its extra built-in surplus power margin. Thus, when it is used as a monophonic amplifier with its built-in bridging circuit, it is able to withstand 4-ohm load impedances and still drive almost any speaker on the market with high stability.

frequency characteristics that are almost comparable to that of Class-A operation. However, the P-266 offers pure Class-A operation with front panel switching. The operational slopes of the push-pull amplifier devices will then overlap each other to produce pure Class-A operation.

Some advantages of Class-A operation are as follows: almost constant current flows from the power supply to the output devices regardless of variations in signal amplitudes; amplifier interior rapidly reaches stable operating temperature. This eliminates excessive heating of devices, and provides highest signal stability. Better power regulation also means less transient distortion. Furthermore, the perfect overlapping of the push-pull output devices operational slopes creates an even purer Class-A operation for the P-266 than in ordinary Class-A operational amplifiers.

Figure 1 shows how Class-A operation is achieved with the bias switching circuit which incorporates an opto-coupler. Normal and Class-A operation is switched by flashing the LED in the bias switching circuit to vary the bias current. This selection is performed by pushing the operation switch on the front panel. The selected mode is indicated by the LED to the left of the multi-function meter.

2 PURE CLASS-A OPERATION — STEREOPHONIC 30 W/ch — MONOPHONIC 110 W.

Since MOS FETs eliminate notching distortion, their use alone assures good high

1 TRIPLE PUSH-PULL MOS FET POWER OUTPUT DRIVES LOW 2-OHM LOADS WITH EASE

The power output stage consists of 3 P-channel and 3-N channel MOS FETs, or a total of 6 MOS FET devices used in a triple push-pull configuration. MOS FETs have been used in a number of Accuphase power amplifiers in the past, and have an established reputation for their elegant sound quality. Their use in a triple push-pull output, together with the heavy-duty power supplies which have a maximum power dissipation (PD) of 600 W, enable the P-266 to deliver sufficiently linear, high-quality signals even into 2-ohm impedance loads, and gives it an unparalleled surplus margin over other amplifiers in its class. The above circuit design is the key to the superiority of the P-266, and its capability to deliver, with ease, 150 W/ch into speaker impedance loads as low as 2 ohms.

This built-in surplus margin protects the P-266 from possible breakdowns that are apt to occur in directly coupled (DC) solid-state amplifiers from excessive current flow through the output devices when low impe-

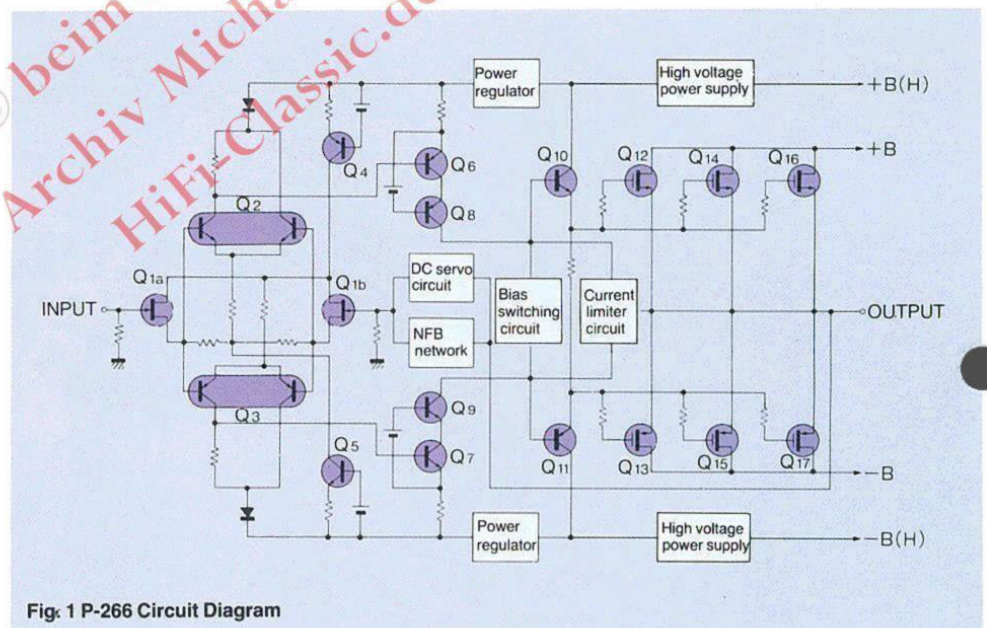

Fig. 1 P-266 Circuit Diagram

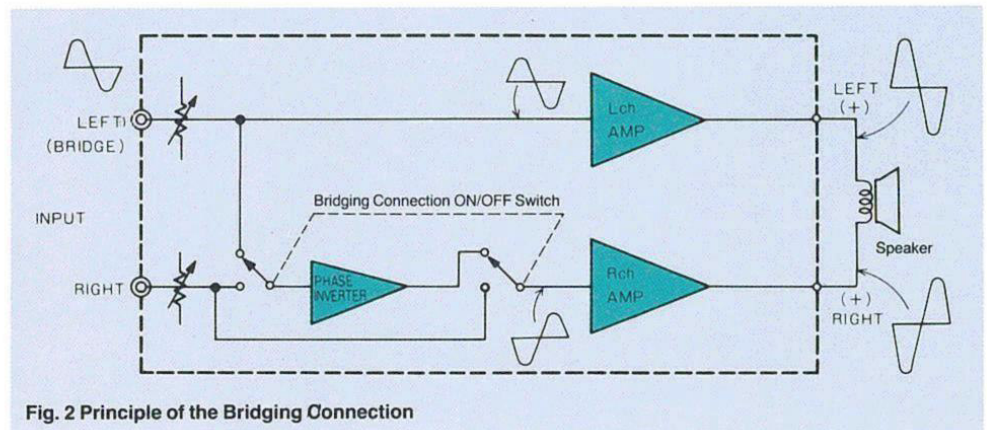

Fig. 2 Principle of the Bridging Connection

300W/ch (at 8 ohms) selectable by Operation Control Switch. Connection. 400W (at 8 ohms)=Class-A 110W (at 8 ohms)

Power output for stereophonic Class-A operation is 30 W/ch (at 8 ohms, 20–20,000 Hz, distortion 0.01%). Also 110 W of pure Class-A monophonic power output is supplied by the P-266 when its built-in bridging circuit is used.

3 HIGH-POWER MONOPHONIC AMPLIFIER WITH POWER BRIDGING CIRCUITRY

The P-266 has a built-in bridging connection which can transform its stereophonic power amplifiers into a high-power monophonic push-pull drive system. The principle is shown in Figure 2 in which an identical waveform is fed to the respective left and right-channel amps in counterphase.

Connecting the speaker to the output of both amplifiers will then double the signal input voltage to that speaker which theoretically quadruples the power of a single amplifier.

Another advantage of counterphase operation is improved characteristics due to the elimination of harmonic distortion as even-number harmonics are cancelled out. Also the plus and minus phases of energy from the power supply are fed alternately to the respective amplifiers, and never in the same direction to both. This should decrease power supply voltage fluctuations and ensure sufficient energy to drive the speaker.

By using the Bridging Drive Switch and the Class-A Operation Switch, the P-266 can be used as (1) standard 130 W/ch Stereo Amplifier, (2) 400 W Monophonic Amplifier; (3) 30 W/ch Pure Class-A Stereo Amplifier and (4) 110 W Pure Class-A Monophonic Amplifier.

Perfect performance is obtained in any of the above modes, so the P-266 can also be used to upgrade your present sound system by employing it in a multi-amplification system or by using it for high-power monophonic amplifier functions.

4 CASCODE PRE-DRIVE STAGE GREATLY IMPROVES HIGH-FREQUENCY PERFORMANCE

Figure 1 shows the circuit diagram of the P-266. The differential amplifier Q2Q3 is followed by a cascode push-pull pre-driver stage Q6–Q9, and then by Q10 Q11 which drives the final MOS FET triple push-pull power outstage Q12 to Q17. The key stage that affects overall amplifier characteristics is the Pre-Driver Q6–Q9 which must supply very large drive voltages to Q10 Q11. Therefore, careful attention was given to its design and in the selection of wideband and high-voltage withstanding devices.

The cascode push-pull pre-driver arrangement already proven in Accuphase P-300X and M-100 was chosen, and it is formed by Q6Q8 and Q7Q9, respectively. Ample high gain is achieved with the common

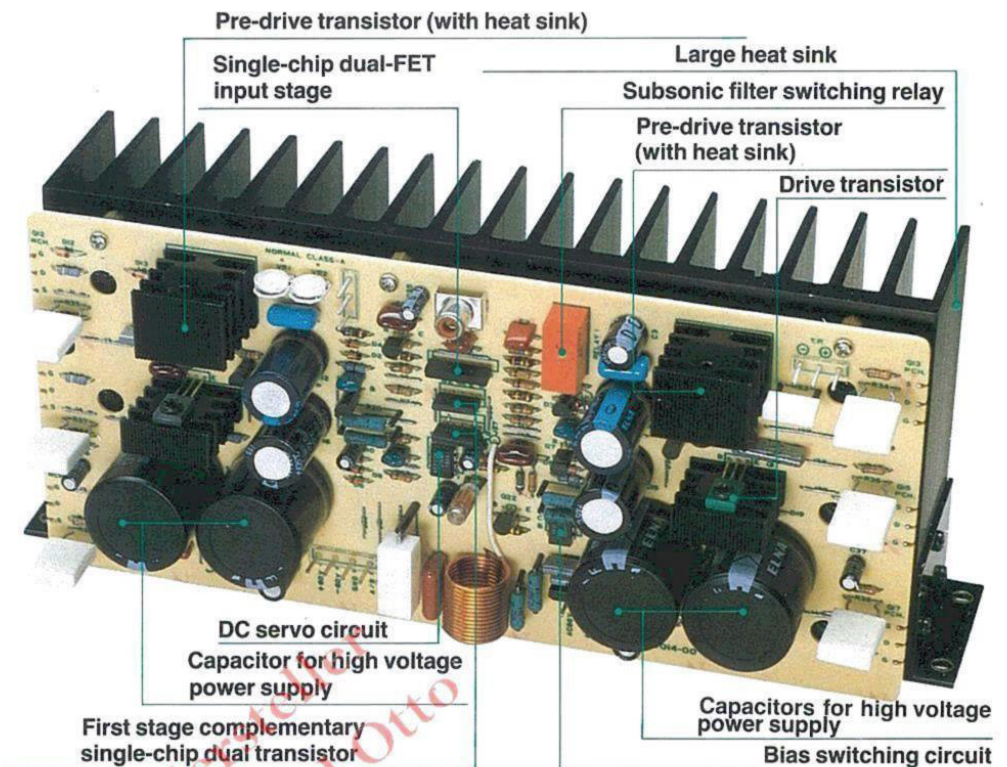

- Power Amp. Unit Ass'y (one channel) MOS FET is mounted between the large heat sink and the PC board.

emitter connection of Q6Q7, and high amplitude voltage with the common ground connection Q8 Q9.

The cascode push-pull pre-driver was also chosen for a number of other valid reasons. Cascode amplifiers have superior high-frequency characteristics free of Miller effects, and so they are usually used in the front end of tuners. Cascode amplifiers also ensure good linearity over the entire operating range of the devices used, and possess better basic characteristics before NFB (Negative Feedback) application.

5 DC SERVO CONTROL CIRCUITRY

As shown in the circuit diagram, the use of Field Effect Transistors (FET) at the input has eliminated the need for input coupling capacitors and permits Direct Coupling (DC amp). This means that DC components in the input signal would also be amplified so that any DC leakage from an associated pre-amplifier could possibly damage the speakers.

To obviate such a possibility, this amplifier is equipped with a DC Servo Control circuit which effectively blocks all DC current leakages and also eliminates any DC drift that may occur within the amplifier itself. The DC Servo Control block in the circuit diagram is placed there for this reason.

6 EACH CHANNEL HAS ITS EXCLUSIVE RECTIFIER CIRCUIT

Exclusive rectifier circuits for each channel have been provided on the respective circuit boards to ensure stable power flow to the pre-amplifying stages. Furthermore, power regulators are provided to regulate energy to meet wide ranging low impedance load requirements.

7 EFFECTIVE 17 Hz CUTOFF SUBSONIC FILTER (–12 dB/oct)

A Subsonic Filter is provided to eliminate very low frequency vibrations such as from discs and other sources that lead to abnormal vibrations of the woofer and cause cross modulation distortion. It effectively cuts off all frequencies below 17 Hz (–12 dB oct) without deteriorating sound quality.

8 1 dB STEPPING –20 dB PRECISION ATTENUATOR

A –20 dB Attenuator provides 1 dB attenuation per step in 20 steps. Its accuracy

"POWER MOS FETs"

The special characteristics of MOS FETs (Metal-Oxide Semi-conductor Field Effect Transistors) that make them the most ideal power amplification device had been known for a number of years by those concerned in the audio world. However, their availability did not take place for a long time because of technical production difficulties that delayed their commercial feasibility. A breakthrough was finally made here in Japan ahead of the world in developing a practical means of producing high power MOS FETs, and these remarkable devices have now become available, and are opening the way for further progress in audio amplification.

The following is a brief summary of some of the advantages of MOS FETs in power amplifier applications.

SUPERIOR HIGH SPEED CHARACTERISTICS ENSURE LOW DISTORTION

A harmful notching distortion caused by a phenomenon known as carrier storage effect occurs at the P-channel and N-channel circuit junction of bipolar transistors when they are used in normal push-pull formation. This distortion occurs especially in the high frequency range, and bipolar transistors must be worked in Class-A operation to eliminate it completely.

This carrier storage effect and notching distortion are not encountered with MOS FETs because of their superior high-speed switching characteristics, so the use of MOS FETs ensures very excellent, low distortion characteristics.

VOLTAGE CONTROLLED MOS FETs PERMIT SUPERIOR DRIVER STAGE DESIGN

MOS FET power transistors have a high input-impedance characteristic and are voltage

controlled devices which require only low current, signal voltages fed to their input to deliver a high power output, unlike bipolar transistors that must be driven by high current, more powerful signals. This means that more ideal operating conditions can be designed for the preceding driver stage when MOS FETs are used in the final stage. Because of the low current requirements, superior low power devices can be utilized. Class-A operation can also be utilized for driver stage amplifiers more easily and improve the overall performance of the amplifier.

MOS FETs PRODUCE HIGH GAIN

The high gain attainable from only one stage of complementary push-pull Power MOS FETs is equivalent to the gain obtained with two or three bipolar transistor amplifier stages. The reduced number of stages for MOS FET amplifiers simplifies signal path circuitry and helps to create a superior power amplifier with higher stability and improved characteristics.

SUPERIOR HIGH FREQUENCY PERFORMANCE

It is advantageous to provide adequate wide-band, high frequency characteristics within the NF (Negative Feedback) loop in audio amplification circuits where large amounts of negative feedback are required. This helps to prevent TIM (Transient Intermodulation Distortion) and obtain a more accurate, faithful reproduction of music. The wideband characteristics of MOS FETs make this possible, and helps to prevent TIM more effectively.

LINEARITY

Compared with Junction-type FETs, MOS FETs have a wider linear range which means that superior performance can be obtained with smaller bias currents and less heat generation, a desirable characteristic for power amplifier devices. In this respect, bipolar transistors are very excellent devices also.

BUILT-IN PROTECTION AGAINST OVERHEATING

MOS FETs have a Negative Temperature Coefficient in the high current area, a characteristic which basically differs from bipolar transistors. This helps to protect itself from damage in case of trouble. For example, if an abnormal current flow occurs resulting from some circuit breakdown, a sudden rise in pellet temperature will cause this negative temperature coefficient of the MOS FET to decrease current flow, reduce heat and protect itself from damage. A similar breakdown may cause thermal runaway with bipolar transistors which would require protective countermeasures and special operational care.

As explained above, MOS FETs have many advantages. However, if we are to mention a weak point, it is that they are costly.

Nevertheless, Accuphase has adopted MOS FETs because of their excellent performance characteristics which, we firmly believe, is well worth the extra cost.

Although certain weak points of bipolar transistors were described in the above comparison with MOS FET devices, we must add that due to constant progress in circuit design technology, there are certain well-designed bipolar amplifiers that are equal in performance, if not superior, to some MOS FET Amplifiers.

is particularly effective in making precise level settings for multi-amplification systems.

9 LOGARITHMIC SCALED PEAK LEVEL METER WITH PEAK HOLD FEATURE

A convenient Peak Level Monitoring Meter is available. It is logarithmically scaled and indicates continuous direct readings of maximum output, both in terms of dB and watts into 8-ohm impedance loads. It can be switched to indicate and hold the maximum power reading position reached in every three-second sampling period.

10 SPEAKER SELECTION AND HEADPHONE JACK

The P-266 can be connected to two separate networks of stereo speaker systems, either or both of which can be activated with a Selector Switch which controls two pairs of output connecting relays. These relays ensure solid connections to the speakers so that they eliminate any possibility of sound deterioration caused by poor connections. A headphone jack is provided which is convenient for late-hour monitoring.

● Internal View of the P-266 Stereo Power Amplifier

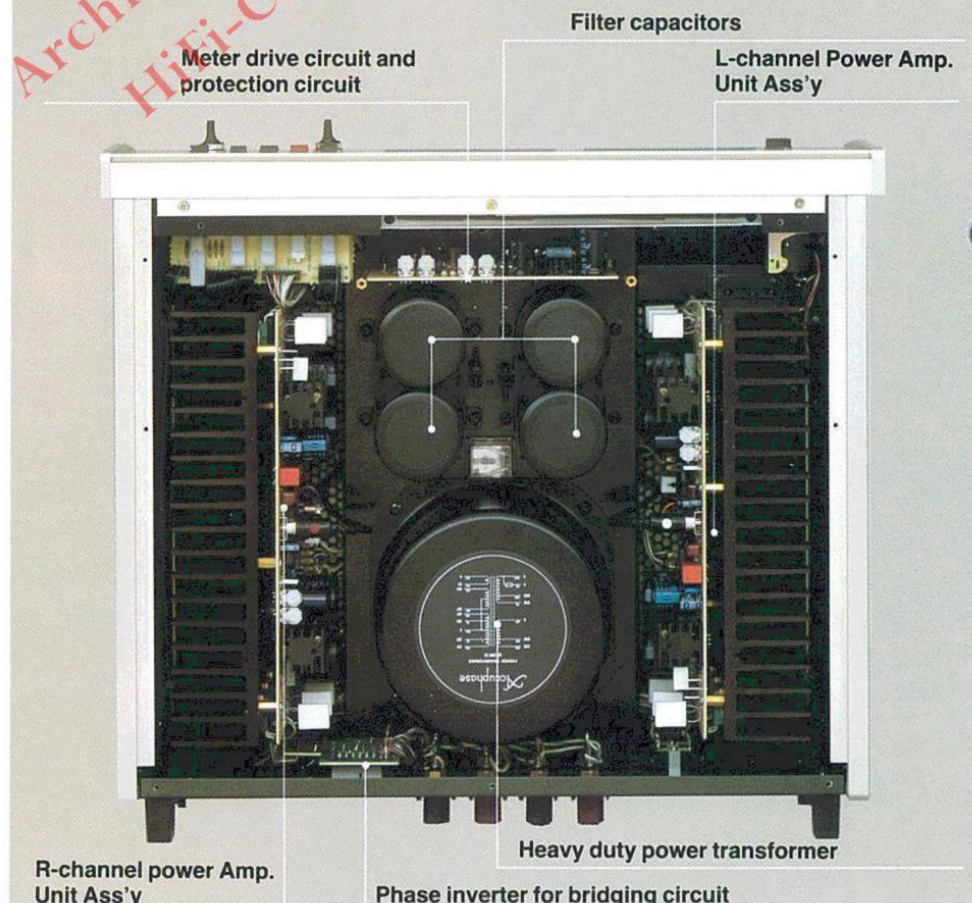

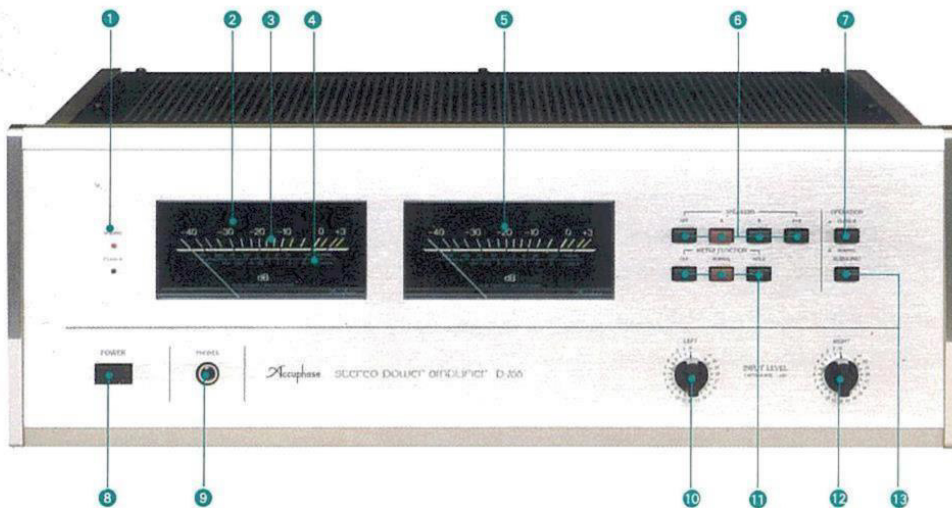

- 1 Operation mode indicator
NORMAL, CLASS-A
- 2 L-channel power level meter
- 3 dB scale
- 4 Wattage scale
- 5 R-channel power level meter
- 6 SPEAKER selector switch
OFF, A, B, A+B
- 7 OPERATION control switch
CLASS-A, NORMAL
- 8 POWER switch
- 9 Stereo headPHONE jack
- 10 INPUT LEVEL control (1dB steps) for L-channel
and bridged monophonic operation
- 11 METER FUNCTION selector switches
OFF, NORMAL, HOLD
- 12 R-channel INPUT LEVEL control 1 dB steps
- 13 SUBSONIC filter
ON OFF 17 Hz - 12dB/oct



- 14 BRIDGE CONNECTION ON/OFF switch
- 15 SPEAKER A R-channel output terminal
- 16 SPEAKER A L-channel output terminal
- 17 INPUT jacks
- 18 SPEAKER B R-channel output terminal
- 19 SPEAKER B L-channel output terminal
- 20 AC Power cord receptacle

GUARANTY SPECIFICATIONS

PERFORMANCE GUARANTY:

All Accuphase product specifications are guaranteed as stated.

CONTINUOUS AVERAGE POWER OUTPUT (IHF Standard):

STEREOPHONIC MODE: Both channels driven, from 20 Hz to 20,000 Hz with no more than 0.01% total harmonic distortion:

NORMAL OPERATION:

400 watts per channel, min. RMS, at 4 ohms
130 watts per channel, min. RMS, at 8 ohms
65 watts per channel, min. RMS, at 16 ohms

CLASS-A OPERATION:

55 watts per channel, min. RMS, at 4 ohms
30 watts per channel, min. RMS, at 8 ohms
18 watts per channel, min. RMS, at 16 ohms

MONOPHONIC MODE (Bridging Connection): from 20 Hz to 20,000 Hz with no more than 0.01% total harmonic distortion:

NORMAL OPERATION:

400 watts, min. RMS, at 8 ohms
180 watts, min. RMS, at 16 ohms

CLASS-A OPERATION:

110 watts, min. RMS, at 8 ohms
55 watts, min. RMS, at 16 ohms

TOTAL HARMONIC DISTORTION:

STEREOPHONIC MODE: Both channels driven, from 20 Hz to 20,000 Hz at any power output from 1/4 watt to rated power:

NORMAL/CLASS-A OPERATION:
0.01% max., at 4 ohms
0.005% max., at 8 ohms to 16 ohms

MONOPHONIC MODE (Bridging Connection): from 20 Hz to 20,000 Hz at any power output from 1/4 watt to rated power:

NORMAL/CLASS-A OPERATION:

0.01% max., at 8 ohms
0.005% max., at 16 ohms

INTERMODULATION DISTORTION (IHF Standard):

Will not exceed 0.003% at rated power output

FREQUENCY RESPONSE (IHF Standard):

20 Hz to 20,000 Hz; +0, -0.2 dB for rated output at the maximum level control

0.5 Hz to 300,000 Hz; +0, -3.0 dB for 1 watt output at the maximum level control

0.5 Hz to 150,000 Hz; +0, -3.0 dB for 1 watt output at -6 dB attenuation

VOLTAGE AMPLIFICATION IN DECIBELS:

27.8 dB at STEREOPHONIC MODE
33.8 dB at MONOPHONIC MODE (Bridging Connection)

OUTPUT LOAD IMPEDANCE:

4 ohms to 16 ohms at STEREOPHONIC MODE
8 ohms to 16 ohms at MONOPHONIC MODE (Bridging Connection)

DAMPING FACTOR (IHF Standard at 50 Hz/8-ohm):

120 at STEREOPHONIC MODE
60 at MONOPHONIC MODE (Bridging Connection)

INPUT SENSITIVITY AND IMPEDANCE:

STEREOPHONIC MODE:
1.3V, 20k ohms, for rated output at the maximum level control

0.12V, 20k ohms, for 1 watt output (IHF Standard)

MONOPHONIC MODE (Bridging Connection):

1.1V, 20k ohms, for rated output at the maximum level control

0.06V, 20k ohms, for 1 watt output (IHF Standard)

A-WEIGHTED SIGNAL-TO-NOISE RATIO:

STEREOPHONIC MODE:
120 dB below rated output, inputs shorted 100 dB at 1 watt output, terminated with 1k-ohm (IHF Standard)

MONOPHONIC MODE (Bridging Connection):
110 dB below rated output, inputs shorted 90 dB at 1 watt output, terminated with 1k-ohm (IHF Standard)

STEREO HEADPHONE JACK: Low Impedance type

SUBSONIC FILTER: 17 Hz cutoff, 12 dB/oct.

POWER LEVEL METER:

Logarithmic-scaled peak level indication of the dynamic range from -40 dB to +3 dB with Peak-Hold circuit, calibrated to read 0 dB at 130 watts in to 8 ohms load

SEMICONDUCTOR COMPLEMENT:

34 Tr's, 18 FETs, 7 ICs, 68 Di's and 2 Opto-couplers

POWER REQUIREMENT:

Voltage selection by rewiring for 100V, 117V, 220V and 240V 50/60 Hz operation

POWER CONSUMPTION (at STEREOPHONIC MODE):

NORMAL OPERATION:
120 watts at zero signal output
500 watts at rated power into 8 ohms load

CLASS-A OPERATION:

150 watts at zero signal output
190 watts at rated power output into 8 ohms load

DIMENSIONS:

445 mm (17-1/2 inches) width, 160 mm (6-5/16 inches) max. height, 373 mm (14-11/16 inches) depth

WEIGHT:

20 kg. (44 lbs) net, 24 kg. (52.8 lbs) in shipping carton

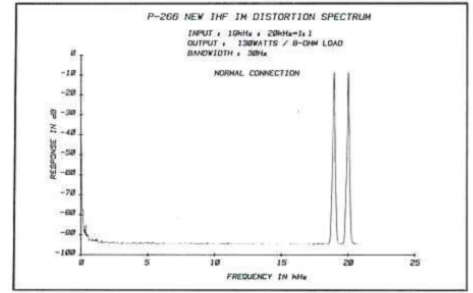
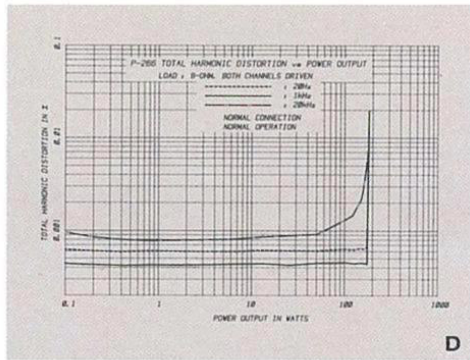
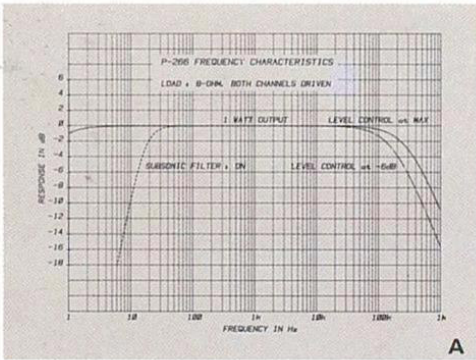

The above data shows the spectrums of intermodulation distortion for the P-266 as measured by the new IHF measurement method. Amplitudes of a 19kHz and 20kHz input signals are shown at the right side. Any intermodulation created by these two signals would appear as spectrum peaks at 1kHz intervals, the frequency difference between the two signals, across the frequency bandwidth. This data shows them to be hardly noticeable, confirming that IM distortion is less than -93 dB (0.0022%).

Another form of IM distortion would appear at 39kHz, the sum of the two input signal frequencies ($19+20=39$ kHz). Such a distortion, even if it existed, would be inconsequential because it is far beyond the audible range. In the P-266, this form of IM distortion is also less than 93dB.

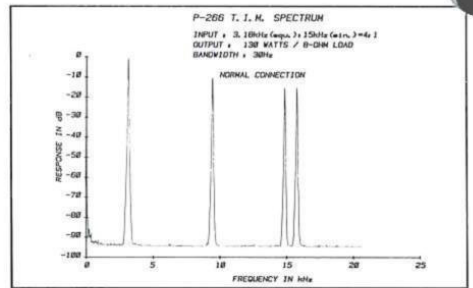
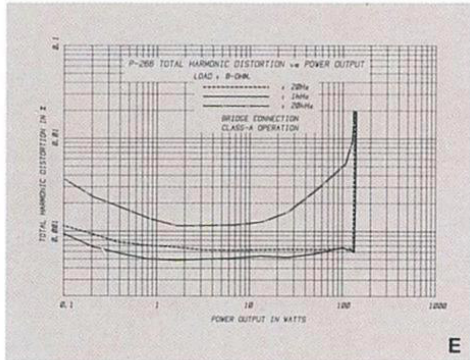
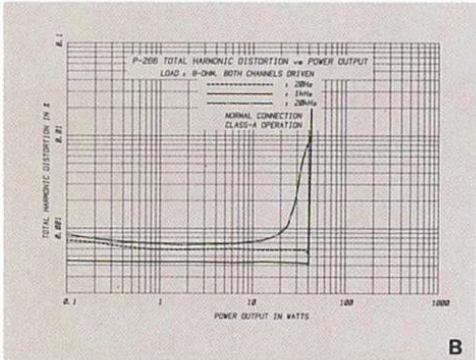

The above data shows the spectrum characteristics of transient intermodulation distortion for the P-266 when two mixed input signals, a 3.18kHz square wave and a 15kHz sine wave, are used. Since harmonics of square waves appear almost infinitely at odd-number multiples, for example in this case at 9.54kHz (3rd harmonic) 15.9kHz (5th harmonic), they can create, together with the 15kHz input sine wave, intermodulated spectrums at frequencies where input signals are absent. For example, if the third harmonic of the 3.18kHz square wave (9.54kHz) and the 15kHz input signal intermodulate, a spectrum can appear at the difference of their frequencies or 5.46kHz ($15-9.54=5.46$ kHz). However, the above data shows no spectrum above -93 dB at that frequency which confirms that TIM distortion is less than 0.0022%.

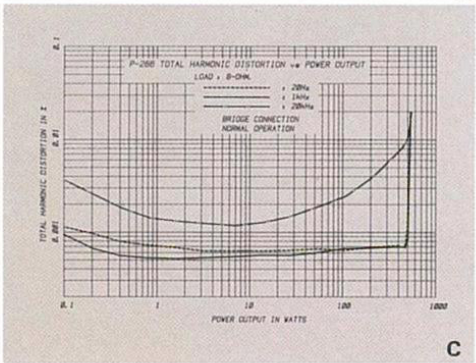

- A Frequency characteristics
- B Total harmonic distortion vs. power output (For normal operation/stereo)
- C Total harmonic distortion vs. power output (For normal operation/bridging connection)
- D Total harmonic distortion vs. power output (Class-A operation/stereo)
- E Total harmonic distortion vs. power output (Class-A operation/bridging connection)

© HiFi-Labeler
 Archiv
 HiFi-Classic.de