

Accuphase

F-25

FREQUENCY DIVIDING NETWORK

●Unitized Amplifiers that Allow Amplification System Configuration from Two to Four Channels ●Gaussian Curve with Superb Phase Characteristic Employed ●GIC Adopted in Each Filter Circuit

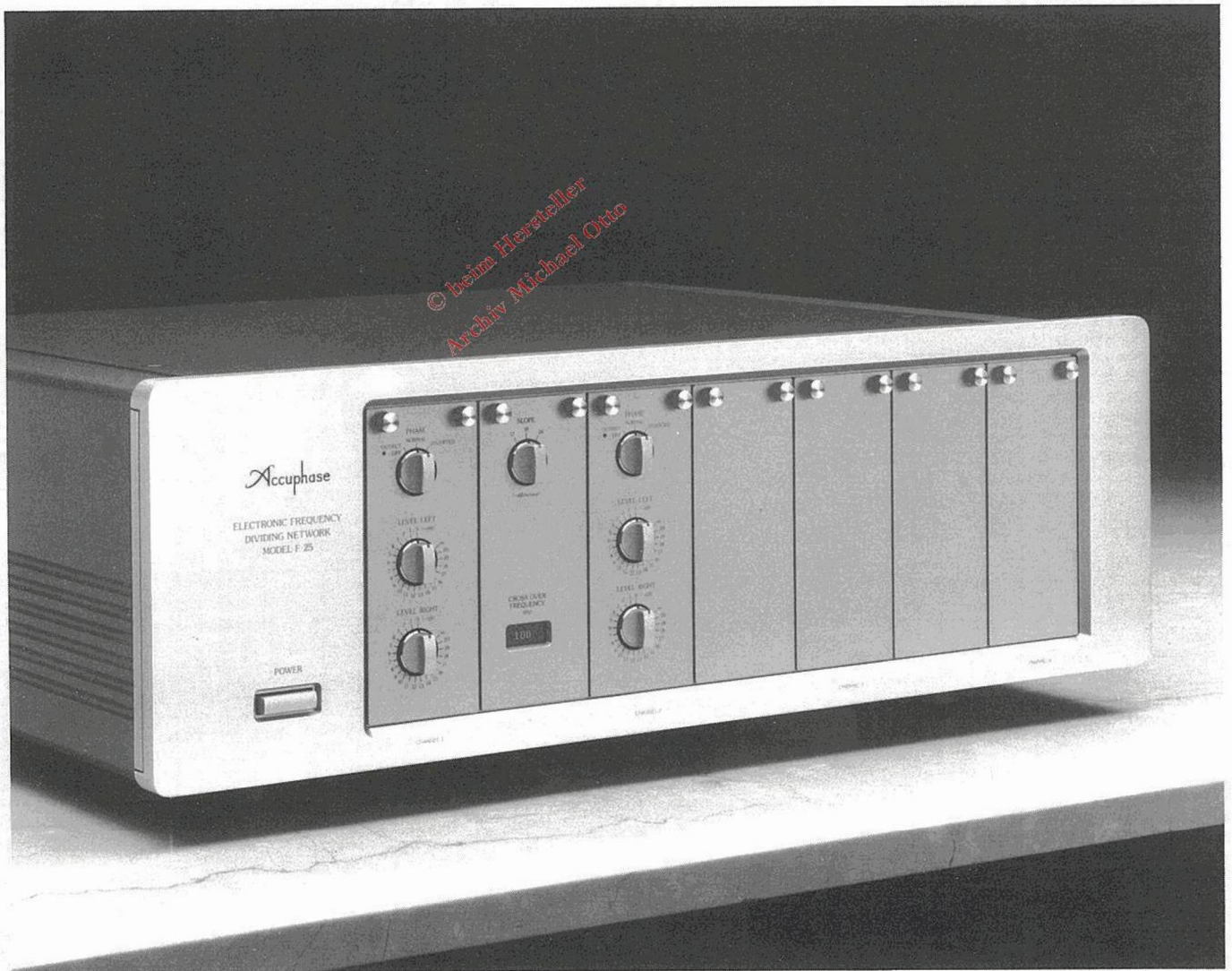



Ultimate in Audio System Technology — High-Performance Multi-channel Frequency Dividing Network Equipped with Balanced I/O Circuits and Serving as the Heart of Multi-amplification System. The Standard Two-amplification System Can Even be Expanded to a Four-amplification System through the Addition of Amplifier Units. GIC type Filter Circuitry and Gaussian Curve with Superb Phase Characteristic Adopted in the Frequency Dividing Network.

A "multi-amplification" system in which the speaker of each audio frequency range is driven with a dedicated power amplifier has been the most contributing factor in sound quality improvements by far, offsetting an inevitable increase in the size of the audio system. Because of its colossal charms as an audio mechanism as well, the multi-amplification system has been recognized worldwide by many audio enthusiasts as the ultimate in audio system technology.

Since the unveiling of its first frequency dividing network F-5 in 1976, Accuphase has been satisfying the requests of audio enthusiasts with the F-15 and F-15L, improved versions of the initial product. We at Accuphase have just completed the development of a new product F-25 by combining generalized immittance converter (GIC) type filters, adopted for the first time in any frequency divider, with our balanced transmission circuit technology cultivated over many years. With the new frequency dividing network in which a two-amplification system has been adopted as its basic system configuration, multi-amplification systems of up to four channels can be implemented by

simply adding line amplifier units, filter amplifier units, and crossover boards available as options to the basic system configuration.

To ensure a better filter curve, the F-25 has adopted the Gaussian curve that improves the phase characteristics. As well known, a music signal is a collection of pulsive signals. Thus, the Gaussian curve that also improves the impulse characteristics is ideal for music signals. With the F-25, the attenuation slope characteristic can be selected with a switch from among three types: -12 dB/octave, -18 dB/octave, and -24 dB/octave.

A generalized immittance converter (GIC) has been used in each filter circuit in the multi-amplification system. The GIC did away with any conventional filter circuit which can be configured only with inductance (L) and capacitance (C) circuit elements and has implemented a filter circuit with resistance (R) and capacitance circuit elements alone. With the GIC type filter circuit, an LC filter circuit can be simulated without using inductance. Moreover, high-precision crossover frequency and attenuation characteristics

can be set by selecting the appropriate circuit constants as required.

Another advantage of the GIC is that since signals in each pass band do not pass through the amplifier, the purity of these signals can be maintained.

For mounting each "Crossover" board which determines the crossover frequency of the network, the method of dismantling the filter amplifier unit and mounting the crossover board inside the filter amplifier unit by interconnecting the board and the unit is employed to prevent deterioration of the sound quality, as well as to allow interconnections at the shortest distances. A crossover board is provided for each frequency. Thanks to the balanced transmission circuit configuration which Accuphase has been promoting for long for both inputs and outputs, there exists virtually no difference in the quality of sound between balanced and unbalanced I/O connections.

With all these improvements incorporated in the F-25, you can enjoy sound reproduction of higher quality than that you've ever hoped to have.

Unitized Amplifiers for Amplification System Configuration from Two to Four Channels

With the F-25, filter amplifiers and line amplifiers have been unitized in such a way that any of these units can be inserted or removed easily from the front panel of its housing. The basic multi-amplification system configuration of the F-25 is a two-amplification system in which one filter amplifier unit and two line amplifier units have been housed as standard equipment.

To upgrade the standard two-amplification system by increasing the number of channels, just add amplifier units available as options to the standard equipment as shown in the photos on the right. Fig. 1 shows a block diagram of the F-25 with a four-amplification system configuration. Through such unitization of amplifiers, Accuphase succeeded in minimizing the crosstalk between channels.

The desired crossover frequency can be selected

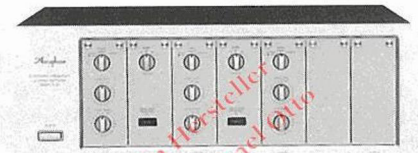

Three-Amplification System Specifications (with added amplifier units)

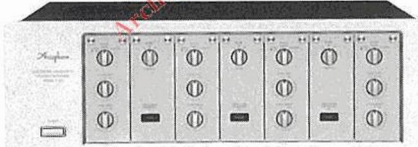

Four-amplification System Specifications (with added amplifier units)

by connecting the crossover board of the applicable frequency to a connector inside the filter amplifier unit so that the crossover board and the filter amplifier unit are interconnected at the shortest distance.

Crossover boards are optionally available in 21 different types to cover crossover frequencies from 70 to 125,000 Hz.

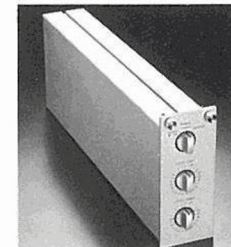

Optional Line Amplifier Unit LA-25



Optional Filter Amplifier Unit DN-25

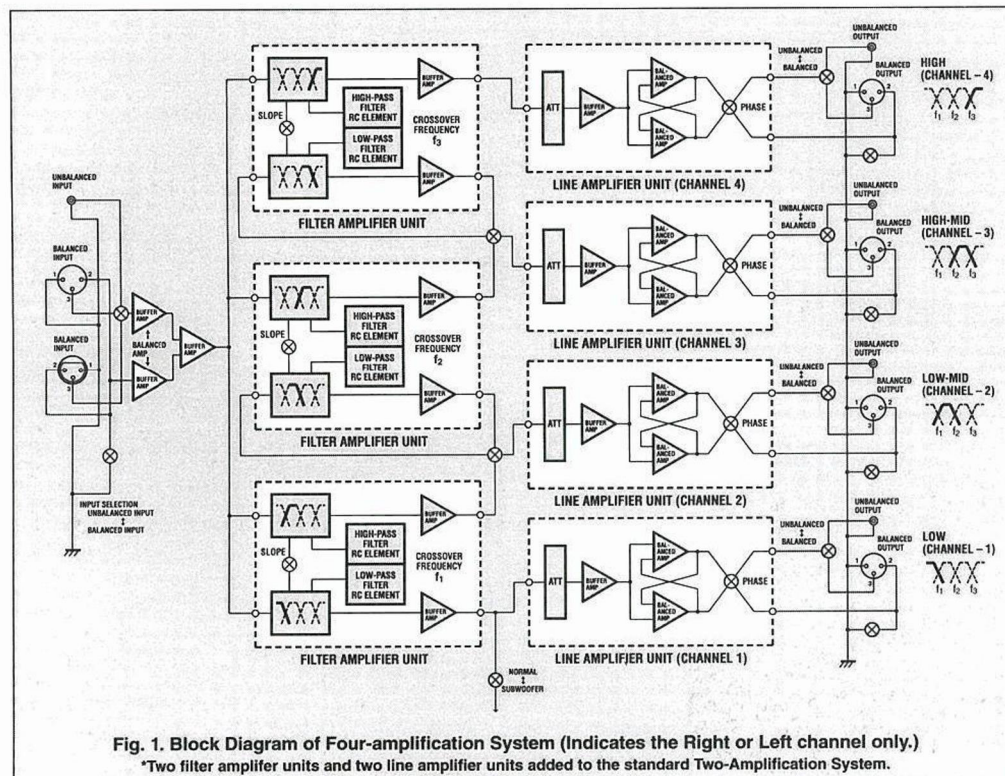

Fig. 1. Block Diagram of Four-amplification System (Indicates the Right or Left channel only). *Two filter amplifier units and two line amplifier units added to the standard Two-Amplification System.

Gaussian Curve with Superb Phase Characteristic Employed as Filter Curve

As the filter curve that divides the frequency, the Gaussian curve has been adopted. This type of filter is also used for high-performance measuring instruments such as an FFT analyzer, etc. As compared with the conventional Butterworth filter, the Gaussian curve type has outstanding impulse reproducibility and thus can faithfully reproduce the original waveform.

The attenuation slope characteristic of the filter can be selected with a switch from among three types: -12 dB/octave, -18 dB/octave, and -24 dB/octave. This characteristic indicates the amount of attenuation per octave. The greater the degree, the greater the amount of attenuation, which improves frequency band separation.

GIC Type Filter Circuits

A generalized immittance converter (GIC) has been used in each filter circuit that creates cutoff characteristics in the multi-amplification system. The basic configurations of the GIC type filter are as shown in Fig. 2 (for LPF) and Fig. 3 (for HPF). The GIC did away with any conventional filter circuit which can be configured only with inductance (L) and capacitance (C) circuit elements and has implemented a filter circuit with resistance (R) and capacitance circuit elements alone. Unlike any conventional feedback type filter circuit, because signals in each pass band do not pass through the amplifier, the purity of these signals can

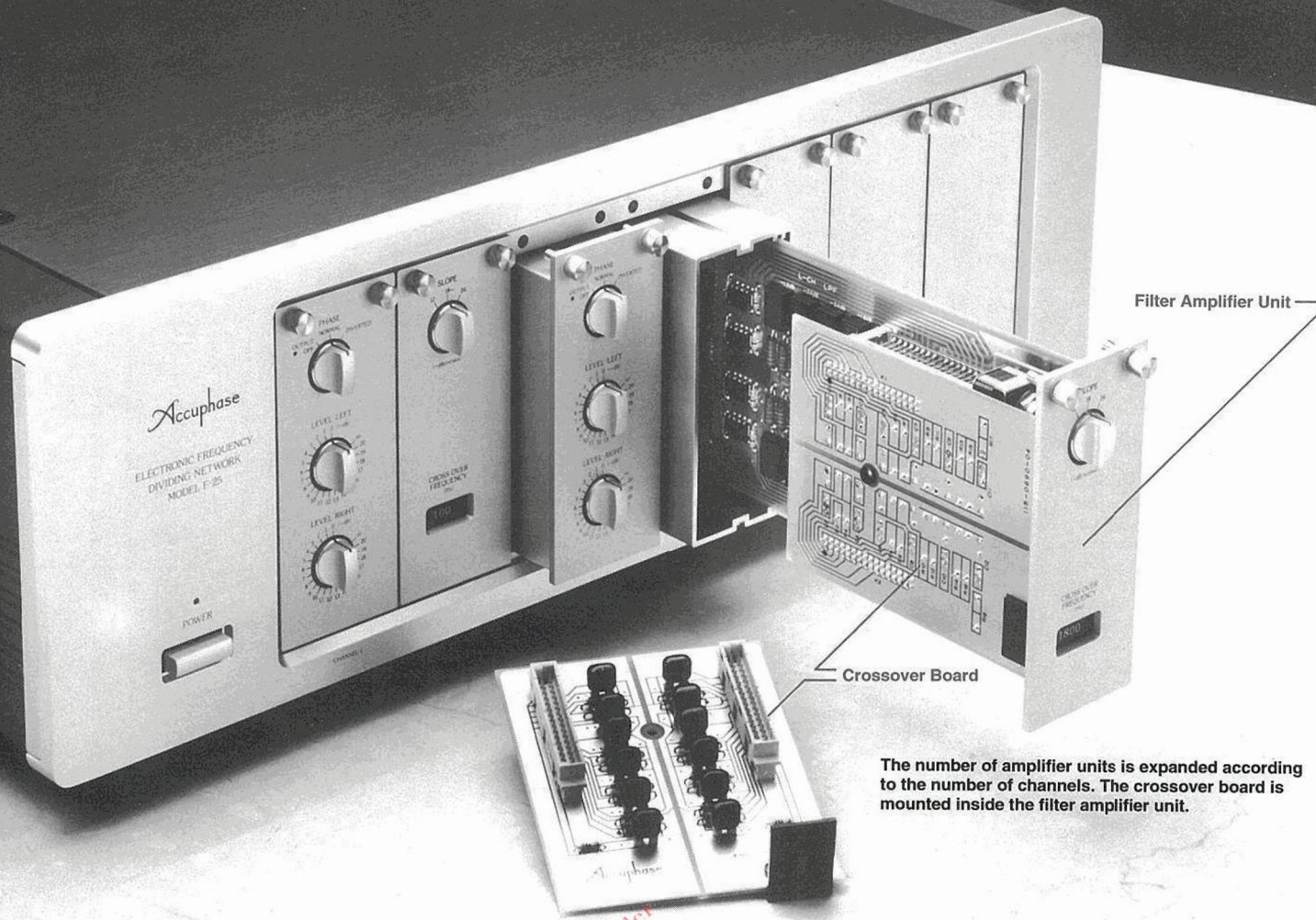

The number of amplifier units is expanded according to the number of channels. The crossover board is mounted inside the filter amplifier unit.

be maintained with the GIC type filter circuit. In addition, the crossover frequency and attenuation characteristics of each filter can be maintained accurately by selecting the appropriate circuit constant.

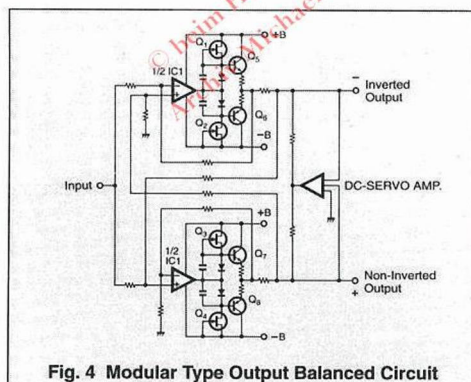
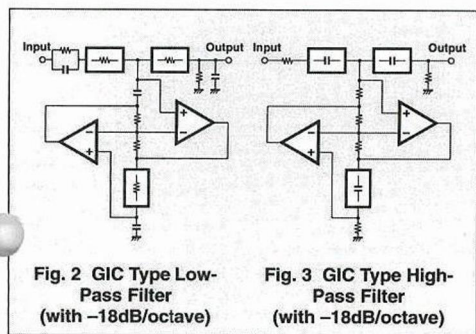

output balanced circuit has been made modular by mounting its main semiconductor circuitry on a printed circuit board made of alumina with excellent thermal conductivity.

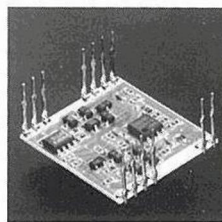

Perfectly Balanced Transmission Circuit Provided for Both Inputs and Outputs

The F-25 is equipped with a complete set of I/O con-

nectors for perfectly balanced signal transmission. Thanks to these inputs and outputs, you can make the most of such an advantage as minimal noise interference especially when a high-efficiency horn speaker is also used. Inputs or outputs for unbalanced transmission can be selected with a switch on the rear panel of the F-25. Because this method is to connect either of the two terminals to ground, the same quality of sound can be obtained in both balanced and unbalanced I/O connections.

The F-25 is also equipped with a phase selector for each channel. However, this selection is possible by merely switching the balanced connection of the output without adding an inverting circuit. Thus, the quality of sound will not be degraded.

Level Controls Adjustable with Emphasis on Sound Quality

In each line amplifier unit, a level adjuster that allows level adjustments within the range of 0 to -20 dB in 1 dB units independently of the left and right channels for each band and an infinite-precision attenuator are provided. In this level adjuster, a mirror-like ground resistor element especially designed for low distortion is used. The resistor element is designed to rotate while its brushes remain fixed. Thanks to this unique structure, the number of metallic contact parts have been lessened, which in turn contributes greatly toward improving the sound quality.

Subwoofer System Also Possible

A "subwoofer system" or "three-dimensional (3-D) system" in which ultralow-range left and right signals each with a broad directivity are mixed and a single large woofer is employed is one way to use an ultra-large woofer effectively in a limited space. To enable this subwoofer system, a switch is provided in the low frequency section on the rear panel of the F-25.

Fully Protective Muting Circuit

Because the F-25 employs unitized plug-in type line amplifiers and filter amplifiers that can be easily inserted or removed from the front of its housing, the F-25 incorporates a protective circuit which causes the muting circuit to activate to shut off all outputs should any of these filter units be accidentally removed while the frequency dividing network is in operation.

Modular Output Balanced Circuit

Fig. 4 shows a circuit diagram of an output balanced circuit. To each of the balanced outputs which have two output ends, feedback is applied as in cross-connection as shown in the diagram. This ensures the maintenance of perfect balance in the case of the balanced output connection. With the unbalanced output connection, all what you need to do is to connect either of the two outputs to ground so that you can configure an ideal output balanced circuit. To implement such output circuit for more stable operation, the



Rear Panel

Internal Block Diagrams of Two- to Five-amplification Systems

(For Four-amplification System, refer to the Fig. 1)

Two-amplification System

- F-25 standard equipment (one Filter Amplifier Unit and two Line Amplifier Units) is used.
- Only one f_1 Crossover Board is required.

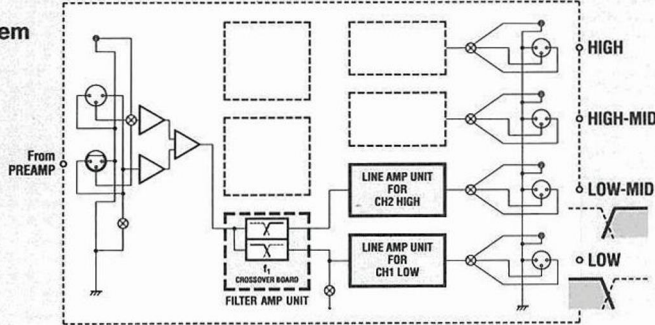

Three-amplification System

- One Filter Amplifier Unit and One Line Amplifier Unit must be added to the F-25 standard equipment.
- One f_1 Crossover Board and one f_2 Crossover Board are required.

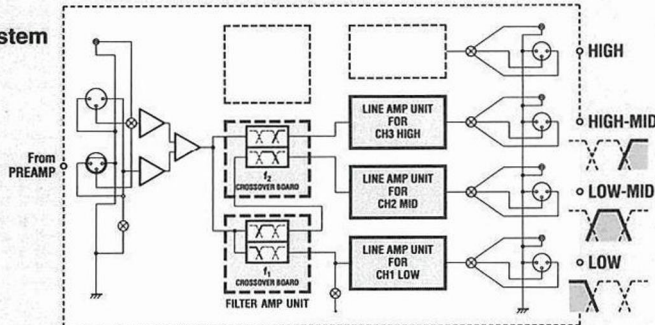

Five-amplification System

- Two F-25 standard equipment sets are required.
- Three Filter Amplifier Units must be added.
- One Line Amplifier Unit must be added.
- One f_1 Crossover Board, one f_2 Crossover Board, one f_4 Crossover Board and two f_3 Crossover Boards are required.

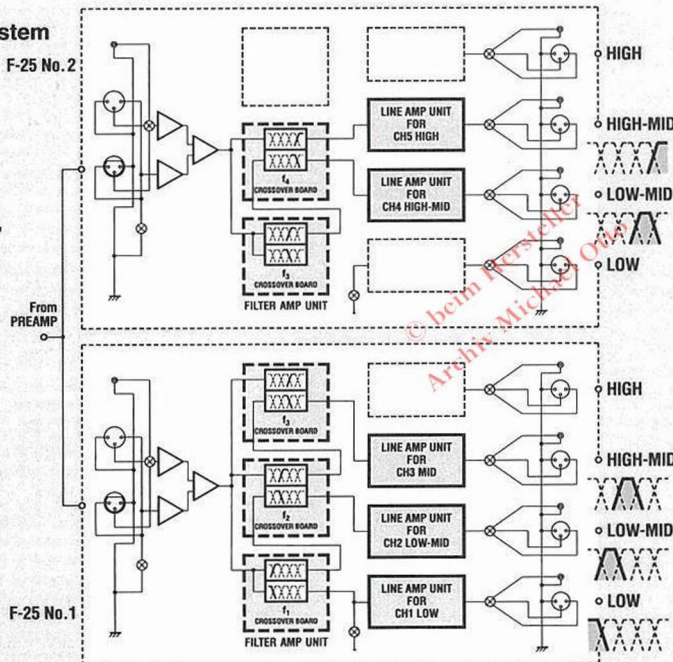

Optional Line Amplifier Units, Filter Amplifier Units, and Crossover Boards

When using the F-25 with an amplification system configuration for more than two channels, the following optional amplifier units must be added to the standard equipment (two-amplification system) according to the number of channels.

- Line Amplifier Unit LA-25
- Filter Amplifier Unit DN-25
- Crossover Boards

All the following 21 crossover boards are also available as options.

Crossover frequency	Model Number	Crossover frequency	Model Number
70 Hz	FB-70	1,000 Hz	FB-1000
100 Hz	FB-100	1,200 Hz	FB-1200
130 Hz	FB-130	1,800 Hz	FB-1800
180 Hz	FB-180	2,500 Hz	FB-2500
250 Hz	FB-250	3,500 Hz	FB-3500
290 Hz	FB-290	5,000 Hz	FB-5000
300 Hz	FB-300	7,000 Hz	FB-7000
350 Hz	FB-350	8,000 Hz	FB-8000
500 Hz	FB-500	10,000 Hz	FB-10000
650 Hz	FB-650	12,500 Hz	FB-12500
800 Hz	FB-800		

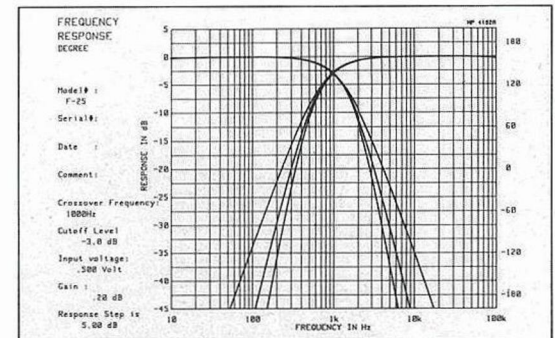

Frequency Response Characteristic — Two-amplification System (-12 dB/octave, -18 dB/octave, -24 dB/octave)

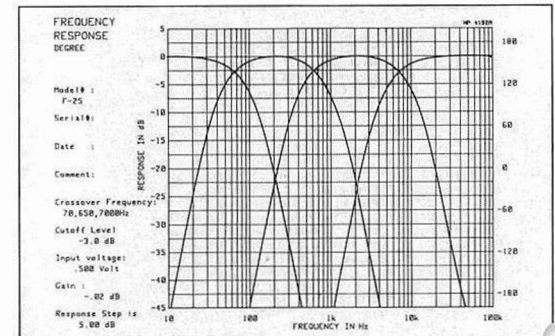

Frequency Response Characteristic — Four-amplification System (-24 dB/octave)

GUARANTY SPECIFICATIONS

(These characteristic data were measured as per EIA Measurement Method RS-490.)

Performance Guaranty:

All Accuphase product specifications are guaranteed as stated.

Maximum Input Level:

BALANCED: 7.0V (with XLR type connector)
UNBALANCED: 7.0V (with RCA phono jack)
(at 20 to 20,000 Hz with THD of 0.01% max.)

Total Harmonic Distortion:

0.003% (at 20 to 20,000 Hz with 2.0V output)

FREQUENCY RESPONSE:

20 to 20,000 Hz +0 dB, -0.2 dB
0.5 to 300,000 Hz +0 dB, -3.0 dB
(with single-channel equivalent band)

Crossover Frequency:

Selectable by swapping the crossover boards.
Standard frequency: 21 points

Crossover Characteristic:

-3.0 dB \pm 5%

Attenuation Slope Characteristic:

-12 dB/octave, -18 dB/octave, or -24 dB/octave
selectable with a switch

Input Impedance:

BALANCED: 40k ohms (20k ohms/20k ohms)
UNBALANCED: 20k ohms

Output Impedance:

BALANCED: 50 ohms
UNBALANCED: 50 ohms

Signal-to-Noise Ratio:

100 dB (at 0.5V output with IHF-A weighted)

Minimum Load Impedance:

BALANCED: 600 ohms
UNBALANCED: 600 ohms

Level Adjustment

0 to -20 dB (Within this range, levels at left and right channels are adjustable independently for each band in 1 dB units.), ∞ (Output OFF)

Power Requirements & Consumption:

100, 117, 220, or 240 V AC, 50/60 Hz 32 W

Maximum Outline Dimensions:

475 mm (18-3/4 inches) width, 170 mm (6-13/16 inches) height, 380 mm (14-15/16 inches) depth

Weight:

16.0 kg (35.3 lbs.) net
21.0 kg (46.3 lbs.) in shipping carton

Accuphase

ACCUPHASE LABORATORY INC.