

Accuphase

ELECTRONIC FREQUENCY DIVIDING NETWORK

F-15L

- All-stage push-pull unit amplifiers
- High-precision level controls adjustable in 0.5 dB units
- Both balanced & unbalanced input/output circuits provided
- Subwoofer system also possible

Hersteller
Michael Otto

© beim Hersteller
Archiv Michael Otto



Both Balanced and Unbalanced Input/Output Circuits Provided, High Effectiveness Electronic Frequency Dividing Network

The "multi-amplification system", in which the crossover frequencies of a multi-amplification system are generated by electronic circuits and the speaker of each frequency range is directly driven by a dedicated power amplifier, has been recognized by many audio enthusiasts as the ultimate system with which one can really relish the zest of audio. Since its advent, it has gained a solid foothold in the audio world, strongly supported by people who prefer an original speaker system of their own.

Although the multi-amplification system tends to be large and bulky because it calls for as many power amplifiers as the number of ranges into which the frequency is to be divided, it can extract the peak performance of the speaker, eliminating adverse effects of the LC network on the sound quality. Especially today, when digital program sources are dominant, it is believed that this system will increasingly make its superb quality felt.

In 1976, in its pursuit of the "ultimate audio system", Accuphase developed a Frequency Dividing Network, Model F-5, which was designed to be the heart of a multi-amplification system, to the acclaim of a large number of audio fans. The F-5 allowed the crossover frequency to be set and changed by merely plugging in a printed circuit board into a slot on the front panel, so that the desired frequency and attenuation characteristics could be consistently obtained. In addition, carefully selected circuit elements improved the sound quality up to the virtual theoretical limits. In 1981, the F-5 was restyled into the F-15, in which the filter unit amplifiers were made up of discrete components to form push-pull circuits. The F-15L is the result of the second model changeover. This Frequency Dividing Network is provided with new balanced input/output circuits and improvements on the features of the F-15. The functions of the power supply have been reinforced, and each element has been reviewed to achieve effective balanced signal transmission.

Among its many features are fine adjustment of the attenuation in 0.5 dB units, capability of creating a subwoofer system, and compatibility with the crossover boards of the F-5 and F-15, to name but a few.

Accuphase believes that this new Frequency Dividing Network completely satisfies the needs and demands for high quality.

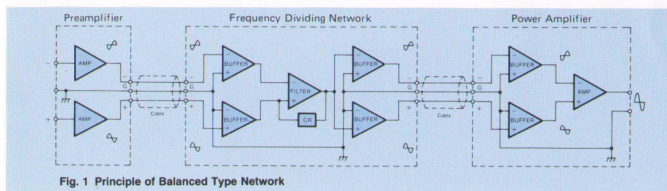

Fig. 1 Principle of Balanced Type Network

1 Both Balanced and Unbalanced Input/Output Circuits Provided

The F-15L Frequency Dividing Network is equipped with a complete set of input/output circuits for balanced signal transmission. Figure 1 shows the operating principle of the balanced signal transmission. Two symmetrical signals, each having the same voltage as the other but opposite phase, are generated and transmitted along a three-core cable from equipment to equipment.

The ground line (G) only connects the ground potential of the signals. No signal current flows through this line. Consequently, noise components the cable may pick up are canceled out and do not appear in the output signals. Moreover, noises from the power lines and sources can be effectively suppressed. As a result, only pure signals can be transmitted. This balanced signal transmission method is widely employed in audio equipment for industrial and professional use in studios and broadcasting stations. In addition to the balanced input/output features, conventional, unbalanced input/output RCA phono jacks are also provided.

2 Low-Noise, Wide-Band Unit Amplifiers of FET-Input, Complementary Push-Pull Configuration

The main constituents of the Frequency Dividing Network are active filter amplifiers and buffer amplifiers. Figure 2 is a block diagram showing the internal circuitry of the F-15L. As can be seen, all the unit amplifiers are of the same 1-gain configuration. In this figure, those numbered 2 to 5 are the active filter amplifiers that are responsible for the crossover frequency characteristics and are a combination of resistors and capacitors.

Those numbered 1 and 6 to 11 are the buffer amplifiers. They serve as buffers to prevent interference from the circuit stages preceding and following them.

As Figure 2 suggests, the performance and sound quality the Frequency Dividing Network can offer depend heavily on the quality of the resistors and capacitors that form the unit amplifier and filter characteristics. Unless the quality of these elements is beyond reproach, having a multi-amplifier system is meaningless.

A unit amplifier must have a simple signal transmission path and provide superior performance. The unit amplifiers of the F-15L form a push-pull circuit as Figure 3 shows, and its input is configured as a low-noise, high-gm FET com-

plementary, source-follower circuit. The output is a complementary push-pull circuit consisting of wide-band transistors.

This output circuit features no loop feedback, while consisting of carefully selected elements, and provides virtual upper-limit characteristics that have been achieved by the push-pull and local feedback methods. The drains of Q_1 and Q_2 are respectively connected to the emitters of Q_6 and Q_5 , to prevent the Miller effect and to suppress distortion over a wide band.

3 DC Servo Output Unit Amplifiers

The unit amplifiers of the F-15L excel in stability, and their gain is 1, effectively eliminating the possibility of DC drift. The occurrence of even a very slight DC drift at the stages preceding the attenuators can cause noise while the level is being adjusted. Moreover, drifts in the output stage can produce DC components in the output of a DC power amplifier, which must be avoided.

To prevent the DC components from generating, and to stabilize the characteristics, the F-15L has DC servo amplifiers as buffer amplifiers at the stages following the filter amplifiers. Those numbered 6 to 11 in Figure 4 are such DC servo amplifiers. The circuit shown in this figure is basically the same as the one in Figure 4, except that servo amplifiers IC_1 and IC_2 are added in Figure 4. The time constants of these servo amplifiers are determined by C_1 , C_4 , and R_1 to R_4 .

This arrangement enables all the unit amplifiers to operate as DC amplifiers without a coupling capacitor, to improve the overall sound quality.

4 High-Precision Level Controls Adjustable in 0.5 dB Units

Three level controls, LOW, MID, and HIGH, normally adjusted in units of 1 dB are provided to each of the left and right channels. The level of each frequency range can therefore be controlled on the front panel of the Frequency Dividing Network, without relying on the power amplifiers. Whereas the attenuators can be adjusted in 1 dB units, the -0.5 dB Shift Switch provided on the right of each of the six level controls allows adjustment in units of 0.5 dB. Therefore, the attenuation can be adjusted to any of as many as 41 points: from 0 to -20.5 dB, and $-\infty$.

5 Crossover Frequency Easily Changeable by Exchanging "Crossover Boards"

The crossover frequency can be easily changed by exchanging "crossover boards", each of which has a specific crossover frequency. The block marked "CROSSOVER BOARD" in Figure 2 denotes these boards. The resistors and capacitors necessary for both the left and right channels are integrated on a single board. For these elements that have important influence on the sound quality, high-precision metal film resistors and high-quality silvered mica capacitors are employed to prevent degrada-

tion and coloration of the sound quality. Installing a crossover board is easy. You just open the subpanel of the front panel, which is released by one touch, and insert the board into a slot. The crossover boards are optional. The table below lists the available standard crossover boards. Twenty-one boards, each with a different frequency, are available. The crossover boards of the F-5 and F-15 can be used on the F-15L.

6 -12 dB/oct. or -18 dB/oct. Attenuation Slope Characteristics Selectable

The cutoff attenuation slope characteristic can be switched between -12 dB/oct., which is the one most commonly used, and -18 dB/oct., which can elicit superb characteristics from horn speakers. The changeover can be made by the selector switches on a crossover board.

7 Subwoofer System Also Possible

A system in which a single large woofer consisting of ultra low-frequency speakers each having a broad directivity is used for reproduction is called a "subwoofer system" or "3-D (three-dimensional) system". This system is very effective for reproducing ultra low-frequency sounds in a limited room space. With the F-15L, a subwoofer system can be fashioned by merely operating a switch on the rear panel.

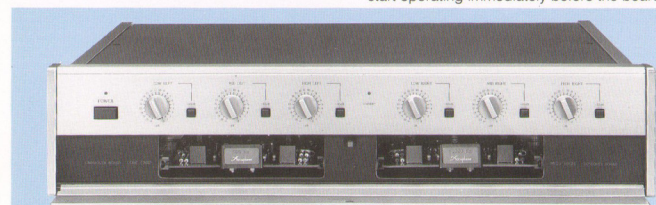

■ Front panel (as viewed with subpanel opened)
The crossover frequency can be changed easily by replacing the crossover board with one having the appropriate frequency.



■ Crossover board

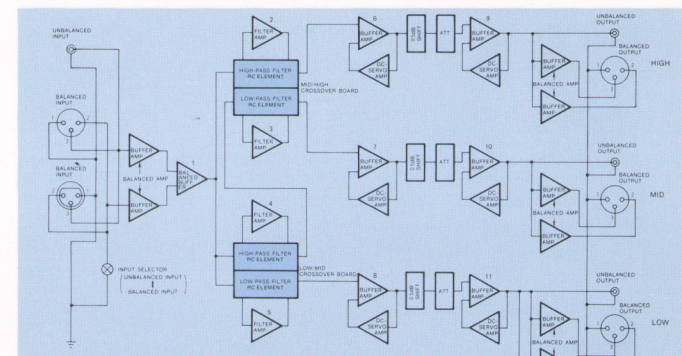

Fig. 2 F-15L Block Diagram (indicates one-channel only)

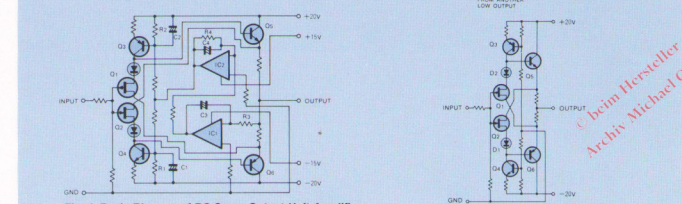

Fig. 4 Basic Diagram of DC Servo Output Unit Amplifier

8 Protective Muting Circuit

If the crossover board is swapped while a Frequency Dividing Network is operating, the chances are that the speakers are damaged by shock noises. To protect the speakers from such possible damage, the muting circuit of the F-15L is equipped with a protective circuit designed to start operating immediately before the board is

disconnected from the socket in a mounting slot, thereby shutting off the outputs.

9 When Using The F-15L For Other Than Tri-Amplification System

The F-15L can be used in a multi-amplification system, such as a tri-amplification, four-amplification, or even a five-amplification system, in addition to a bi-amplification system. To use the Frequency Dividing Network in a bi-amplification system, simply insert the "2-way board" supplied as an accessory into the MID/HIGH slot on the front panel. To form a four-amplification or a five-amplification system, another F-15L is necessary.

MODEL NO. OF THE CROSSOVER BOARDS

Crossover frequency	Model No.	Crossover frequency	Model No.
70 Hz	CB-70	1,000 Hz	CB-1000
100 Hz	CB-100	1,200 Hz	CB-1200
130 Hz	CB-130	1,800 Hz	CB-1800
180 Hz	CB-180	2,500 Hz	CB-2500
250 Hz	CB-250	3,500 Hz	CB-3500
290 Hz	CB-290	5,000 Hz	CB-5000
300 Hz	CB-300	7,000 Hz	CB-7000
350 Hz	CB-350	8,000 Hz	CB-8000
500 Hz	CB-500	10,000 Hz	CB-10000
650 Hz	CB-650	12,500 Hz	CB-12500
800 Hz	CB-800	2-Way Board	CB-2Way

Internal Block Diagrams of Bi-Amplification To Five-Amplification Systems

BI-AMPLIFICATION SYSTEM

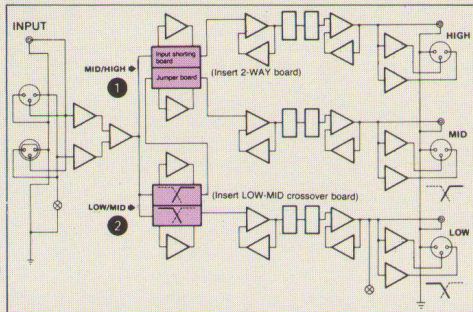

TRI-AMPLIFICATION SYSTEM

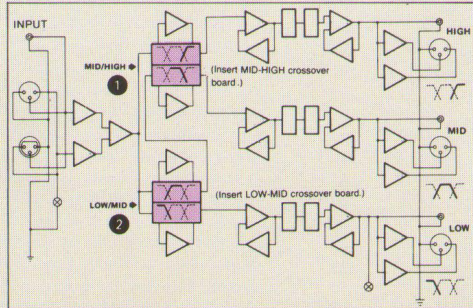

Because the Bi-amplification system uses only one crossover frequency, a LOW/MID crossover board is inserted into the LOW/MID slot and the 2-way board supplied as an accessory to the F-15L unit is inserted into the MID/HIGH slot. The Tri-amplification system represents the most typical application of the Frequency Dividing Network.

FOUR-AMPLIFICATION SYSTEM

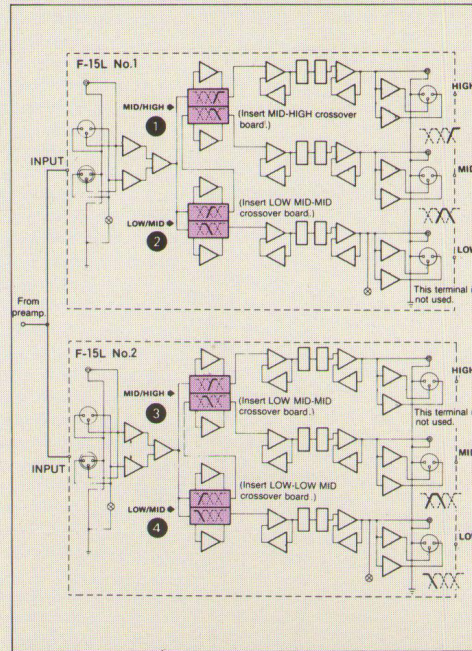

With the Four-amplification system, two F-15L units are used. These two units must be connected in parallel with each other so that an output from the preamplifier is input to the both units at the same time. In this case, the crossover boards (2) and (3) must of the type having the same frequency. This would add extra cost to your budget, but you can expect reproduced sound of a higher quality. The LOW OUTPUT terminal of the No. 1 unit and the HIGH OUTPUT terminal of the No.2 unit are not used.

FIVE-AMPLIFICATION SYSTEM

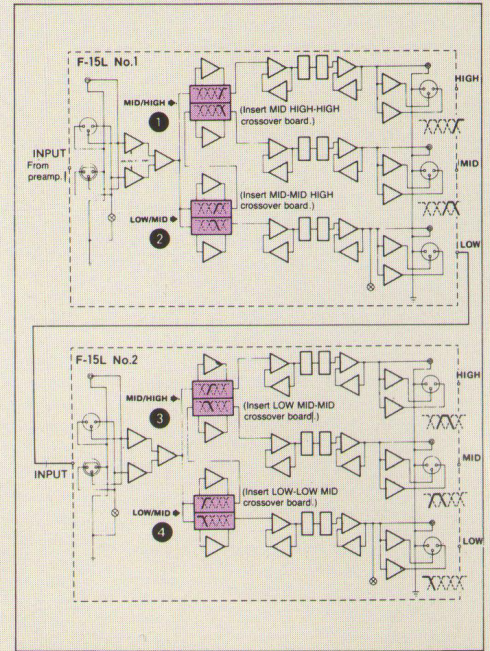

With the Five-amplification system, two F-15L units are connected in series. In this case, to prevent degradation of S/N ratio, an output from the preamplifier is connected to the IN terminal for MID/HIGH band of the No. 1 unit and an output from the LOW OUTPUT terminal of the No. 1 unit is input to the IN terminal of the No. 2 unit. Outputs from the No. 1 unit are HIGH and MID-HIGH from top and outputs from the No. 2 unit are MID, MID-LOW and LOW from top.

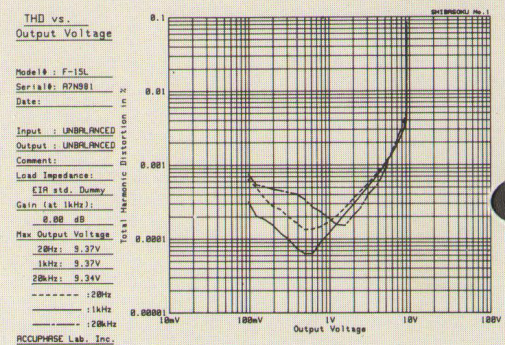
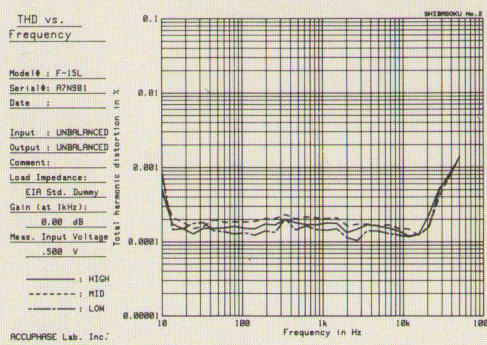
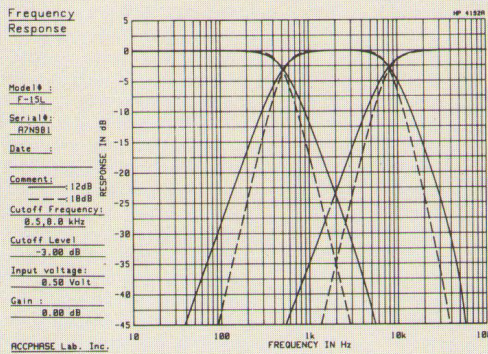

GUARANTY SPECIFICATIONS (in accordance with EIA RS-490 standard measuring methods)

- **PERFORMANCE GUARANTY:**
ALL Accuphase product specifications are guaranteed as stated.
- **GAIN**
0 dB
- **MAXIMUM INPUT**
UNBALANCED: 8.0 V
BALANCED: 8.0 V
(from 20 to 20,000 Hz with no more than 0.01% total harmonic distortion)
- **TOTAL HARMONIC DISTORTION**
0.003% (from 20 to 20,000 Hz, at 2.0V output)
- **FREQUENCY RESPONSE**
20 to 20,000 Hz; +0, -0.2 dB
0.17 to 1,000,000 Hz; +0, -3.0 dB
(equivalent bandwidth)

- **CROSSOVER FREQUENCY**
Selectable by exchanging crossover board
Standard frequency; 21 points
- **CROSSOVER CHARACTERISTICS**
-3.0 dB \pm 5%
- **SLOPE CHARACTERISTICS**
-12 dB/oct., -18 dB/oct. changeable
- **INPUT IMPEDANCE**
UNBALANCED: 20k ohms
BALANCED: 40k ohms
- **OUTPUT IMPEDANCE**
UNBALANCED: 100 ohms (LOW/MID/HIGH)
BALANCED: 50 ohms (LOW/MID/HIGH)
- **MINIMUM LOAD IMPEDANCE**
UNBALANCED: 1k ohms
BALANCED: 600 ohms

- **SIGNAL-TO-NOISE RATIO**
100 dB (at 0.5 V output, A-weighted)
- **LEVEL ADJUSTMENT**
0 to -20.5 dB (Each band independently variable in 0.5 dB units)
- **SEMICONDUCTORS COMPLEMENT**
100 Tr's, 56 FET's, 22 IC's, 58 Di's
- **POWER REQUIREMENTS & CONSUMPTION**
100/117/220/240 VAC 50/60 Hz 30W
- **DIMENSIONS**
445 mm (17-1/2 inches) width, 109 mm (4-5/16 inches) max. height, 373 mm (14-11/16 inches) depth
- **WEIGHT**
9.1 kg (20 lb) net, 13.0 kg (28.6 lb) in shipping carton