

# Accuphase

## INTEGRATED STEREO AMPLIFIER

# E-205

- Parallel push-pull output stage:  $80W \times 2 (8\Omega)$
- Low impedance speaker can be fully driven
- DC servo-controlled throughout
- Signal path controlled by logic circuit



# All unit amplifiers directly coupled in DC servo configuration

## Signal purity preserved from disc input to output

### Design to ensure stable characteristics even at low load impedance

The Accuphase **E-205** Integrated Stereo Amplifier has been perfected, drawing on the sophisticated development technologies accumulated in the field of high-class separate amplifiers. The **E-205** has a rated power output of 80 watts/channel at 8 ohms (20 Hz to 20,000 Hz; distortion ratio less than 0.02 percent) targeted to equal the high-quality power of such separate amplifiers.

*Quality power*, namely, the power necessary to reproduce excellent sound quality is strongly demanded in this era of digital program sources such as CDs (Compact Discs), digital tape recorders, BS (Broadcasting Satellite), and so on. However, a large power output alone is not sufficient to perfectly reproduce the sound from these sources with excellent presence as well as with musical detail, depth, diffusion, and sonority. That is where it differs from *Quality power*, a synonym for reproduction capability of such real presence. To achieve *Quality power*, the **E-205** was designed based on carefully selected circuit elements, ample margin of reserve power output, component layout conducive to stable operation, rugged construction, etc., adhering to Accuphase's development philosophy to challenge all aspects to the limit.

We paid special attention to the capability to drive **low-impedance** loads, which is a fundamental requisite to materialize high-quality power. As a result, the **E-205**, with its powerful output stage and large power supply, has a rated power output of 110 watts/channel at 4 ohms. Furthermore, it is able to deliver adequate power even when the load impedance is 2 ohms, meaning the delivery of adequate energy with the highest stability and fidelity to any type of speakers.

Nowadays, the sound of the video equipment such as VCR (Video Cassette Recorder) is generally reproduced by an audio system. To cope with these trends, an amplifier must be able to cope with connection to many program sources. A record player, a tuner, a CD player, two tape recorders, plus three other program sources can be connected to the **E-205** and the desired program source selected by merely a touch.

## 1 Parallel-push pull output stage driven by a MOS FET driver stage. Large power supply and powerful output stage drive even low-impedance loads (2 ohms).

The circuit diagram for the power amplifier section is shown in Fig. 1. The power output stage employs a **parallel push-pull** configuration, providing a rated power output of 80 watts/channel at 8 ohms so that an adequate power is output. The advantage of the **E-205** lies in the driver stage that is the preceding stage to the power output stage. As can be seen from Fig. 1, the driver stage consists of **MOS FETs**. A MOS FET is an ideal element for the driver stage from which a low output impedance and a high driving voltage are required. This driver stage, along with the low emitter resistance in the output stage, provides extremely high-quality output, free of notching distortion.

The output stage of a power amplifier provides the energy to the speakers. The actual impedance of a speaker fluctuates a lot across the speaker's frequency range. Consequently, the actual impedance of a speaker system having a nominal impedance of 4 ohms may drop to as low as 2 ohms or below for some frequency ranges. Therefore, a power amplifier should be capable of supplying sufficient energy to the low-impedance loads. On the other hand, an increasingly large current flows through a solid-state

amplifier in proportion to decreases in the load impedance, which may result in destruction of output transistors. Hence, the output level for low impedance is severely restricted. Nevertheless, as digital equipment and devices are increasingly used in recent years, the demand for amplifiers that can supply sufficient power to low-impedance loads is growing.

The power amplifier of the **E-205** has a high-power output having a  $P_c$  (maximum power dissipation) of about 400 watts and is provided with a large-capacity transformer, which is quite a high capacity to be employed in an amplifier of **E-205's** class. Thus, an output power as high as 110 watts per channel has been realized at a 4-ohm load. Even when the load impedance is 2 ohms, sufficient output can be obtained.

## 2 Directly coupled circuitry with DC servo preserves signal purity from disc input to output.

The **E-205** employs a virtually ideal configuration in which unit amplifiers of all stages are directly coupled. This construction guarantees that the original signal is amplified and output in a virtually unaltered state to provide an extremely high level of fidelity. To eliminate DC drift completely, a problem that exists in all directly coupled amplifiers, a powerful DC servo is used to stabilize each unit amplifier.

## Power Amplifier Unit (Single Channel)

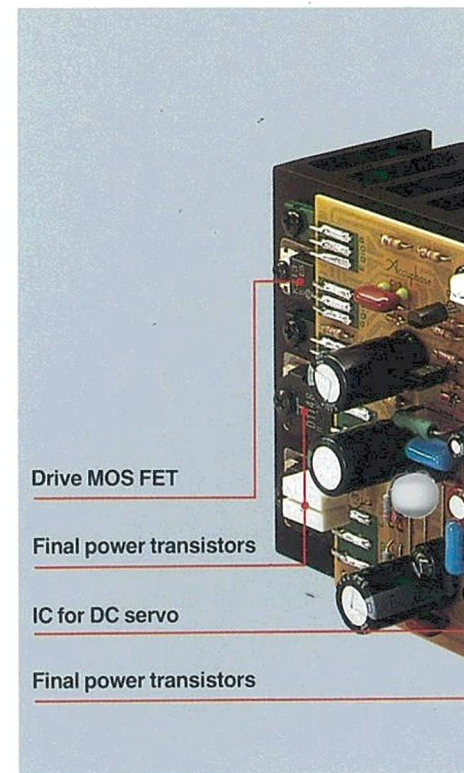

## 3 High-gain equalizer with a high signal-to-noise ratio and MC input impedance selector switch ensure the best use of analog discs.

The equalizer amplifier for analog discs employs, as shown in Fig. 2, a **single channel amplifier system** in which the gain of a high-gain equalizer amplifier is changed over according to that required by an **MC** (moving magnet) or **MC** (moving coil) cartridge. In this system, the provision of an amplifying circuit that can stably operate irrespective of any quantitative change in **NFB** (negative feedback) and the taking of proper countermeasures against residual noise that may occur when an **MC** cartridge is used are important.

To ensure high stability, the input stage of the equalizer amplifier employs a **bootstrap cascode differential amplifier** consisting of transistors and FETs, thereby significantly improving the high-frequency characteristics, the key to high stability. The next stage is a high-performance operational amplifier followed by a complementary push-pull circuit in the final stage. Thus, the amplifying circuit has such a fundamentally pure and simple configuration excels in stability.

Regarding the signal-to-noise ratio when an **MC** cartridge is used for input, the residual noise is significantly reduced by employing in the input stage six FETs connected in parallel. When

# Accuphase E-205

INTEGRATED STEREO AMPLIFIER

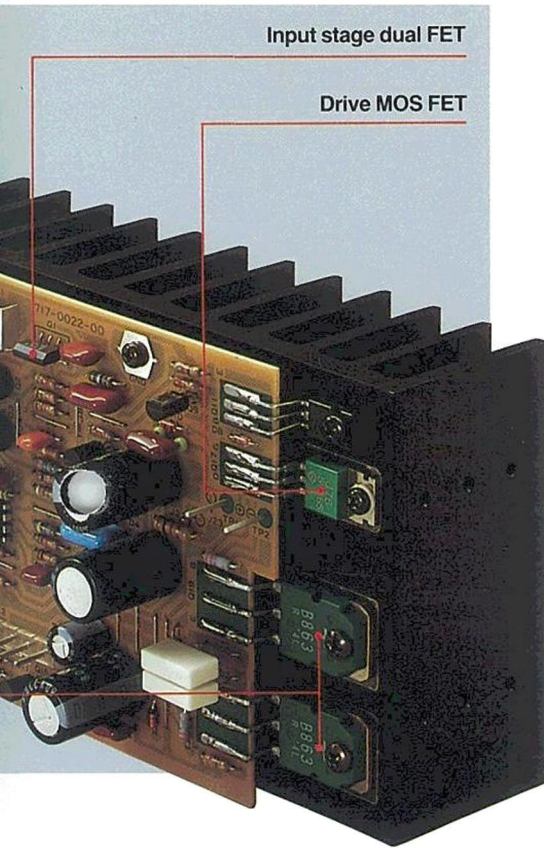

## 5 Turnover selector switch

A turnover selector switch is provided to expand the tone control function. This provides selection of 200 Hz and 500 Hz turnover frequencies for BASS, and 2 kHz and 7 kHz for TREBLE. The turnover selections of 200 Hz and 7 kHz are especially effective for smooth control over the widest range from the deepest bass to the highest treble tones. Furthermore, a 10-step detent type control permits accurate 10-step tonal variations as well as on/off switching of the tone control circuit.

## 6 Tape monitor and dubbing switches

Two tape decks can be connected to the E-205 at once for convenience and versatility. The tape monitor switch permits monitoring the signal being recorded, and the dubbing switch permits copying (dubbing) a tape from one deck to the other regardless of the input selector's position.

## 7 Other functions and facilities

The E-205 is also equipped with many other useful features. A subsonic filter is used to eliminate subsonic noise generated by record warps. An attenuator allows lowering the volume level without disturbing the volume control. A speaker switch lets you switch between two speaker systems or use both at once. A stereo/mono mode switch permits switching to monophonic reproduction to check for correct phase response between the left and right speaker systems. These and many more controls mean the E-205 is fully prepared to handle any listening or recording need.

## 8 Two colors are available for the front panel: champagne gold and black

The color of the front panel is *champagne gold*, the traditional color of Accuphase products. In addition, a black front panel is available as Type E-205B.

MC cartridge is used, a gain of 60 dB can be obtained at the high-gain equalizer amplifier, which is 30 dB up from the 30-dB gain obtainable when an MM cartridge is used. This feature allows use of any type of MC cartridge. Moreover, the optimum load impedance (10, 30, or 100 ohms) best suited to the cartridge to be used can be selected by the input impedance selector switch.

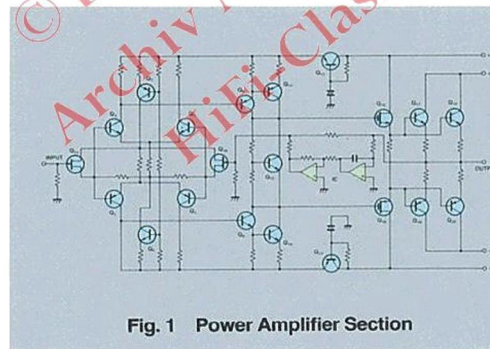

Fig. 1 Power Amplifier Section

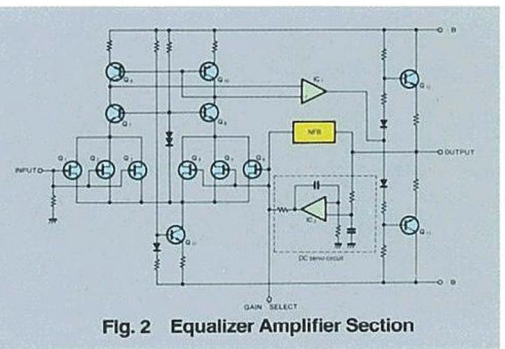
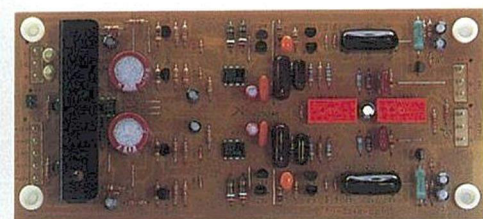

Fig. 2 Equalizer Amplifier Section



High-Gain Equalizer Amplifier Circuit Board

## 4 Up to nine program sources can be connected.

The E-205 is provided with input jacks for a total of nine input systems: two analog discs (one MM and one MC), a tuner, a CD, three line inputs, and two tape inputs. Therefore, in addition to an analog record player, a tuner, a CD player, and two tape recorders, a CTR, a video disc, and a digital recorder can be connected to the integrated stereo amplifier and the desired program source can be selected by just one touch.

### • Top View of Layout

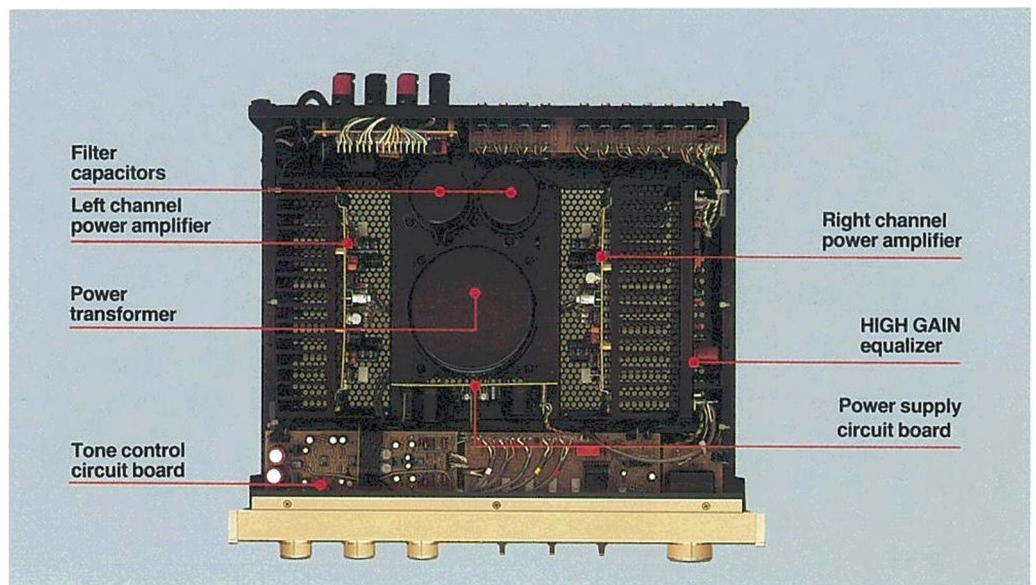

# Accuphase E-205

INTEGRATED STEREO AMPLIFIER

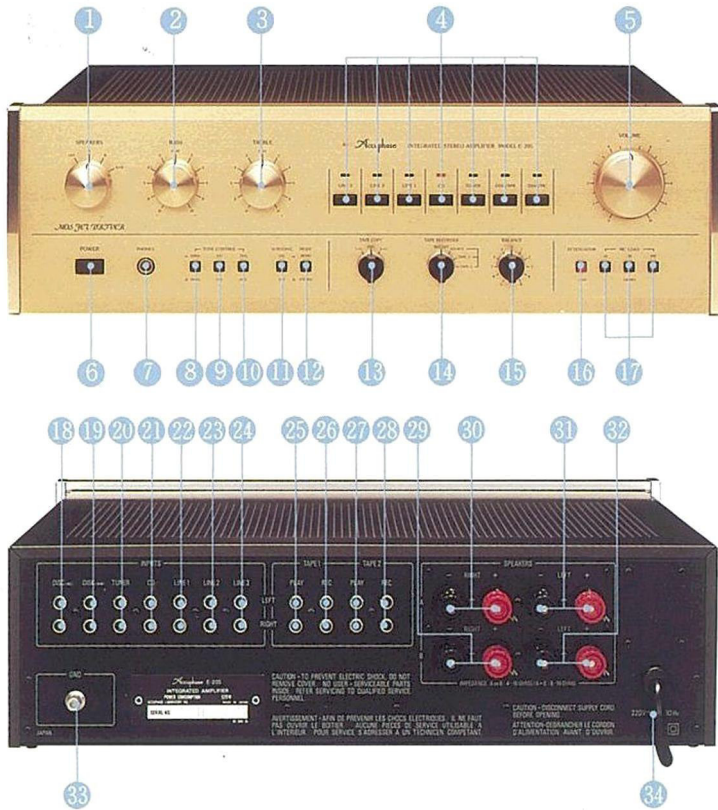

- 1 SPEAKERS selector switch
- 2 BASS control
- 3 TREBLE control
- 4 Input selector
- 5 VOLUME control
- 6 POWER switch
- 7 Stereo headPHONES jack
- 8 TURNOVER selector 200Hz/500Hz
- 9 TONE control ON/OFF switch
- 10 TURNOVER selector 7kHz/2kHz
- 11 SUBSONIC filter
- 12 MODE selector switch
- 13 TAPE COPYing control
- 14 Tape monitor/recording output ON/OFF selector switch
- 15 BALANCE control
- 16 ATTENUATOR
- 17 MC cartridge LOAD selector
- 18 DISC input jacks (for MC cartridge)
- 19 DISC input jacks (for MM cartridge)
- 20 TUNER input jacks
- 21 CD input jacks
- 22 LINE 1 input jacks
- 23 LINE 2 input jacks
- 24 LINE 3 input jacks
- 25 TAPE 1 input jacks
- 26 TAPE 1 recording output jacks
- 27 TAPE 2 input jacks
- 28 TAPE 2 recording output jacks
- 29 RIGHT channel output terminals for speaker B
- 30 RIGHT channel output terminals for speaker A
- 31 LEFT channel output terminals for speaker A
- 32 LEFT channel output terminals for speaker B
- 33 GND terminals
- 34 AC power cord

## GUARANTY SPECIFICATIONS

**PERFORMANCE GUARANTY:**  
All Accuphase product specifications are guaranteed as stated.

**POWER OUTPUT: (EIA)**  
Both channels driven, from 20 to 20,000Hz with less than 0.02% total harmonic distortion  
110 watts per channel min. RMS, at 4 ohms  
80 watts per channel min. RMS, at 8 ohms  
40 watts per channel min. RMS, at 16 ohms

**TOTAL HARMONIC DISTORTION: (EIA)**  
Both channels driven from 20 Hz to 20,000 Hz at any power output from 0.25 W to rated power  
0.02% max., at 4 ohms  
0.01% max., at 8 ohms  
0.01% max., at 16 ohms

**INTERMODULATION DISTORTION: (EIA)**

Will not exceed 0.01% at rated power output

**FREQUENCY CHARACTERISTICS: (EIA)**  
High Level Input: 20 to 20,000Hz; +0, -0.2dB at rated power output

: 2.5 to 150,000Hz; +0, -3.0dB at 1 watt power output

Low Level Input: 20 to 20,000Hz; +0.2, -0.5dB at rated power output

**DAMPING FACTOR: (EIA)**  
100, 8-ohm load at 50Hz

**INPUT SENSITIVITY AND IMPEDANCE:**

| Input terminal   | Sensitivity     |                  | Impedance      |
|------------------|-----------------|------------------|----------------|
|                  | At rated output | EIA At 1W output |                |
| DISC INPUT (MC)  | 0.09mV          | 0.01mV           | 100, 300, 1000 |
| DISC INPUT (MM)  | 2.84mV          | 0.32mV           | 47kΩ           |
| HIGH-LEVEL INPUT | 89.8mV          | 10mV             | 20kΩ           |

**MAXIMUM INPUT FOR DISC:**  
MM input: 300mV RMS at 1kHz, 0.005% THD (REC OUT)  
MC input: 9.5mV RMS at 1kHz, 0.005% THD (REC OUT)

**OUTPUT LEVEL AND IMPEDANCE:**  
TAPE REC OUTPUT: 89.8mV, 220 ohms (from DISC)  
HEADPHONES: 0.2V with low impedance (4 to 100 ohms)

**GAIN:**  
HIGH LEVEL INPUT-OUTPUT: 49dB  
DISC INPUT (MM)-TAPE REC OUTPUT: 30dB  
DISC INPUT (MC)-TAPE REC OUTPUT: 60dB

**SIGNAL-TO-NOISE RATIO:**

| Input terminal   | Inputs shorted, A-Weighted | EIA S/N |
|------------------|----------------------------|---------|
| HIGH-LEVEL INPUT | 103dB                      | 80dB    |
| DISC INPUT (MM)  | 85dB                       | 78dB    |
| DISC INPUT (MC)  | 68dB                       | 78dB    |

**TONE CONTROLS:**

11-position click-stop, Bass and Treble controls, Turnover frequency switches and tone ON/OFF switch.

**Bass:**  
Turnover frequency 200Hz; ±10dB at 50Hz  
Turnover frequency 500Hz; ±10dB at 100Hz  
**Treble:**  
Turnover frequency 2,000Hz; ±10dB at 10kHz  
Turnover frequency 7,000Hz; ±10dB at 50kHz

**SUBSONIC FILTER:** 17Hz, -12dB/oct

**ATTENUATOR:** -20dB

**OUTPUT LOAD IMPEDANCE:** 4 to 16 ohms

**SEMICONDUCTOR COMPLEMENT:** 66 Tr's, 11 IC's, 24 FET's, 71 Di's

**POWER REQUIREMENT:**  
Voltage selection by rewiring for 100, 117, 220 240V 50/60Hz operation

**CONSUMPTION:**  
55 watts at zero signal output, 305 watts at rated power output into 8-ohm load

**DIMENSIONS:**

445mm (17-1/2 inches) width, 145mm (5-12/16 inches) max. height, 370mm (14-9/16 inches) depth

**WEIGHT:** 14.0 kg (30.8 lb.) net, 17.6 kg (38.8 lb.) in shipping carton.

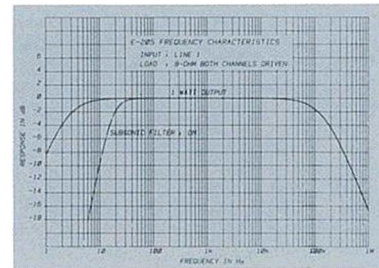
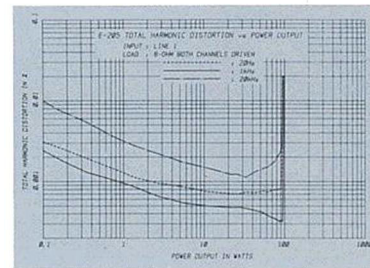
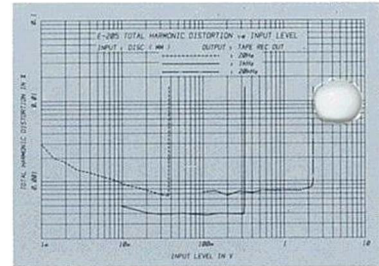
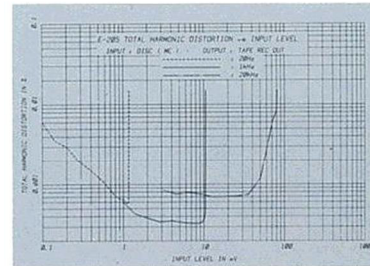

**Accuphase**  
ACCUPHASE LABORATORY INC.