

Accuphase

Integrated Stereo Amplifier E-203

Power MOS FET



© beim Hersteller
Archiv Michael Otto
HiFi-Classic.de

- 70W/CH REALIZED WITH MOS FETs
- SERVO CONTROLLED DC AMPs
- BUILT-IN HEAD AMP
- BUILT-IN LOW-PASS FILTER FOR SUB WOOFER SYSTEM

Accuphase E-203

INTEGRATED STEREO AMPLIFIER

Kensonic Laboratory has called upon the highest grade separate amplifier design technology to create the Accuphase E-203 Integrated Stereo Amplifier. Its power output stages employ MOS FETs (Metal-Oxide Semiconductor Field Effect Transistors) which are considered the most advanced, ideal devices for such applications. They are used in complementary-symmetry push-pull output stages that give full play to their superior characteristics to produce a far superior, outstanding sound quality.

The E-203 has a power output of 70 watts per channel (8-ohm load, 20 – 20,000 Hz, less than 0.01% distortion) which is ample for even the most spacious hi-fi home listening rooms. It is a pure DC amplifier which produces practically no sound coloration because of its special DC Servo Control system for its tone control sections and power output stages.

One of the main features of the Accuphase E-203 is the extra rich bass reproduction that becomes a possibility because of its built-in, low-pass filter network whose output can be fed to separate sub woofer system. A richer bass emphasis can be obtained by connecting monophonic power amplifier and sub woofer to this filter output.

1 70W/CHANNEL REALIZED WITH MOS FETs

"What is the ideal power output device?"

This question has long been a subject of debate, but ever since the potentialities of the MOS FET were revealed at the Audio Engineering Society (U.S.A.), in May, 1976, it became apparent, without question, that this active device held the most promise for the future. However, the birth of high power MOS FETs took a long time due to technical production difficulties. It was finally realized here in Japan ahead of the world. As a result, audio amplifier performance has now entered a new era.

The E-203 employs these powerful MOS FETs. Two of them are used in a push-pull output stage, and account for the high output power of 70 watts per channel.

Since the MOS FET has characteristics which make it easier to use than bipolar transistors or V-FETs, and also because there is no notching distortion during high frequency transmission, there is a significant improvement in treble response. Moreover, its high frequency characteristics are excellent and effectively confine harmful TIM (Transient Intermodulation Distortion) to a minimum.

It does not create notching distortion because of its extremely high input impedance, and also because it is voltage controlled, and requires very little power from the previous stage. This makes it possible to utilize a class-A driver amplifier stage with the result that superior characteristics, closer to the ideal class-A operation, can be realized than with bipolar transistors.

Moreover, the MOS FET has a very high gain equivalent to two or three stages of directly coupled Darlington Pair amplifier circuits using bipolar transistors. The number of stages can therefore be reduced, and superior performance achieved.

The bipolar transistor may seem to have many shortcomings from the above explanation. It was presented only as a matter of comparison, however, it is true that a high perfection amplifier can be made even with bipolar transistors if it is well-designed.

2 BUILT-IN LOW-PASS FILTER FOR SUB WOOFER SYSTEM

Small speaker systems invariably lack sufficient bass response. Yet, the lower frequency bass region forms the very foundation of music. A lively, soul-stirring musical reproduction cannot be realized without sufficient bass.

The E-203 is, therefore, provided with a built-in, low-pass filter network to which can be connected to a sub woofer system (mono amp and special woofer) to obtain a very rich, luxuriant bass response. The low-pass filter network has three, high-side cutoff frequencies of 50Hz, 70Hz and 100Hz, from which the most suitable can be selected, depending on the left and right channel bass response of your speaker systems.

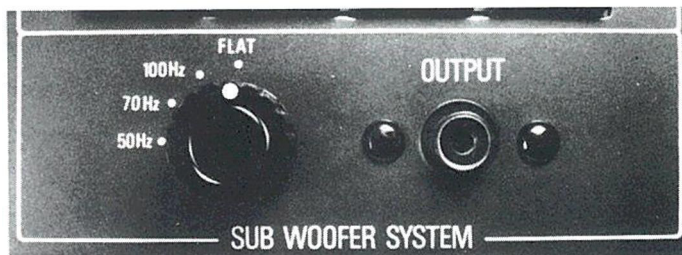

3 DC UNIT AMPS THROUGHOUT - DC SERVO CONTROLLED HIGH-LEVEL AMPLIFIER AND POWER AMPLIFIER STAGES

All unit amps are DC types, with pure DC amplifier design adopted throughout. Large capacity, direct current blocking capacitors in the NF loops have been completely eliminated so there is no sound coloration.

This was accomplished by effectively controlling DC drift which had been generally recognized as very difficult in high-level amplifier sections that contain tone control elements, and where switches and volume control change the value of NF elements.

A new DC Servo Control system was developed to achieve this. It has effectively eliminated DC drift at the output and has permitted direct coupling of even the power amplifier stages, as well as pure DC amplifier operation even when the tone control circuit is ON.

4 ICL (Input Capacitor-Less) DESIGN

In order to reduce further the tonal coloration effects of capacitors, the input capacitors of unit amplifiers were also eliminated. As a result, there is only one capacitor used in the signal path circuit all the way from AUX and TUNER inputs to the final output.

5 LOW NOISE, WIDE DYNAMIC RANGE HEAD AMPLIFIER

The input circuit of the Head Amplifier employs ultra-low-noise transistors in a differential amp circuit, which together with the low impedance of the NF loop are the reasons for the high S/N ratio of 70dB (at rated input). Any type Moving-coil cartridge can be connected directly without fear of clipping distortion because of the wide dynamic range of the Head Amplifier (maximum input voltage 10mV rms).

6 HIGH S/N EQUALIZER AMP

Low noise active devices must be used in the equalizer input circuit to achieve high S/N ratio, but this alone is insufficient. Low noise parts and elements must be used as well. Low impedance of the feedback loop is also most important to obtain low current-noise and thermal-noise.

Class-A operation with large current flow in the final equalizer transistors has lowered the impedance of the NF loop, and greatly reduced the noise generated at the differential input circuit. The S/N ratio is 77dB (at rated input) which is close to the theoretical limit.

7 HIGH PERFORMANCE POWER TRANSFORMER WITH C-I CORE

A high efficiency, low flux leakage, C-I shaped core type power transformer is used. It is the same type as those AC power line transformers on electric posts which can readily meet the widely changing load requirements for electricity in homes.

- 70W/CH REALIZED WITH MOS FETs
- SERVO CONTROLLED DC AMPs
- BUILT-IN HEAD AMP
- BUILT-IN LOW-PASS FILTER FOR SUB WOOFER SYSTEM

Dual, balanced type windings account for the low flux leakage, high efficiency and good regulation of this superior type transformer. Another advantage is that less wire is required for the same number of turns, and means smaller size and lighter weight.

8 TURNOVER SELECTOR SWITCH

A turnover selector switch is provided to expand the tone control function. This provides selection of 200 Hz and 500 Hz turnover frequencies for BASS, and 2 kHz and 7 kHz for TREBLE. The turnover selections of 200 Hz and 7 kHz are especially effective for smooth control over the widest range from the deepest bass to the highest treble tones. Furthermore, a 10-step detent type volume permits accurate 10-step tonal variations, as well as on/off switching the tone control circuit.

9 TWO-STEP LOUDNESS COMPENSATION

Two-Step Loudness Compensator switch provides a choice of two sound energy balancing curves to make up for the deficiency of the human ear to detect certain audio frequencies during low-level reproduction. This switch also helps to balance out listening room characteristics. COMP 1: +9dB at 50Hz, and COMP 2: +10dB at 50Hz and also +6dB at 20 kHz. (above values with volume control at -30dB).

10 SUBSONIC FILTER

The provision of filters was based on practicality, and only a 17 Hz 12dB/oct subsonic filter is made available. It is an active filter that was designed to cut off frequencies below 17 Hz that sometimes might cause intermodulation distortion in the audible frequency range.

11 OTHER FUNCTIONS

This amplifier is equipped with many other useful functions such as a -20dB Attenuator Switch which is convenient to start off records, a Disc Input Impedance Selector Switch, and a Switch that permits separation of the preamp and the power amplifier.

Four LEDs (Light Emitting Diodes) are located to the left of the INPUT selector switch on the front panel. One of them will light up to indicate the input source that is selected.

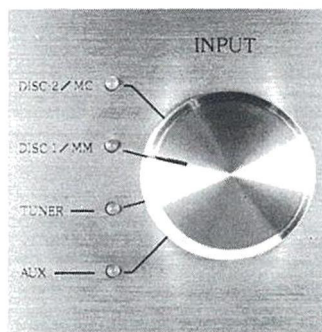

SUB WOOFER SYSTEM

The smaller the speaker system, the less are the low frequency reproduction and richness of sound volume achieved. A bigger speaker system can solve this problem but it may create a new problem of setting space restricted by the size of the listening room. If this is the case, a single low frequency speaker set at the center between the left and right channel speakers can reproduce richly the super low frequency range consisting of mixed low frequency from both the channels. This method is known as the SUB WOOFER SYSTEM.

Any fear of inferiority as to stereo separation by employing this system of mixing both the left and right channels is unnecessary, since the lower the frequency of signal, the less the human ears are

sensitive to the direction of the sound. The reason being that human hearing is sensitive to the time delay (phase difference) of the sound wave between the two ears and to the difference of sound pressure level upon the ears by which the direction of the sound is distinguished. However, as low frequency sound produces very little time delay of the sound between the left and the right ears, it is very hard to distinguish its direction.

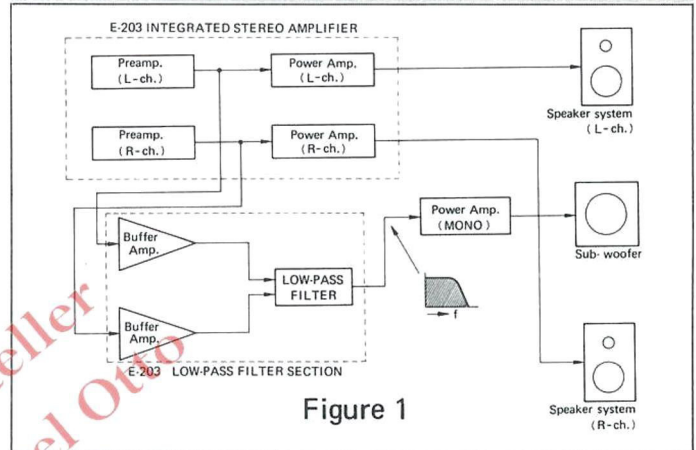

Figure 1

Figure 1 is the block diagram of E-203 employing the sub woofer system. The sub woofer circuit consists of a pair of buffer amplifiers, a low-pass filter, a monophonic power amplifier and a sub-woofer.

When a stereo signal (from the left and the right channel preamplifiers) is fed to the buffer amplifiers, it is converted into a monophonic signal by the buffer amplifiers without impairing the stereo separation at the respective preamplifier output stage. The converted signal is then fed to the low-pass filter to cut off high frequency signal components exceeding 50 Hz, 70 Hz or 100 Hz — determined by the cut-off frequency selector located on the rear of E-203.

Meanwhile, the remaining components are passed to the monophonic power amplifier to drive the sub woofer, thus obtaining rich bass tones which otherwise may be impossible with conventional stereo speaker systems.

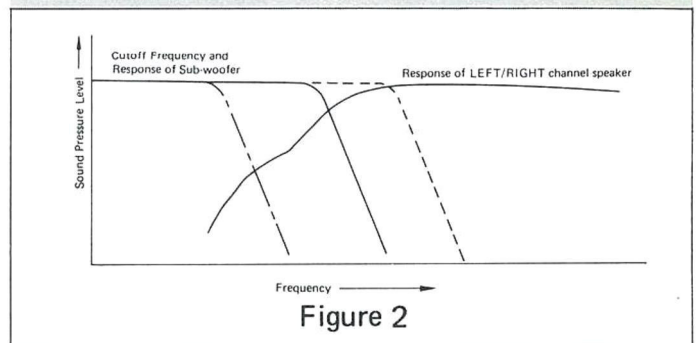

Figure 2

When employing a sub woofer system, the selection of the appropriate cut-off frequency is a very important step. That is, as seen in Figure 2, the suitable cut-off should be set as shown by the solid line so that the sub woofer compensates low frequency decline of the main speaker system. As shown by the dotted line, if the cut-off frequency is too high, it makes a frequency peak at the crossover point. On the other hand, as shown by the broken line, if the cut-off frequency is too low, it makes a non-linear frequency response. The sharper the cut-off of the filter used, the better the stereo separation that is provided. However, as the upper limit of cut-off (which is free from interference against good stereo separation) is recognized as up to 100 Hz, there is no fear of deterioration of good stereo separation provided the cut-off is set at a frequency of 70 Hz or lower.

GUARANTY SPECIFICATIONS

PERFORMANCE GUARANTY:

All Accuphase product specifications are guaranteed as stated.

CONTINUOUS AVERAGE

POWER OUTPUT: (New IHF Standard)

both channels driven, from 20 Hz to 20,000 Hz with no more than 0.02% total harmonic distortion + N:
 90 watts per channel, min. RMS, at 4 ohms
 70 watts per channel, min. RMS, at 8 ohms
 35 watts per channel, min. RMS, at 16 ohms

TOTAL HARMONIC

DISTORTION + N: (New IHF Standard)

both channels driven, from 20 Hz to 20,000 Hz at any power output from 1/4 watt to rated power:
 0.02 % max., at 4 ohms
 0.01 % max., at 8 ohms
 0.01 % max., at 16 ohms

INTERMODULATION DISTORTION: (New IHF-IM) will not exceed 0.005% at rated power output

FREQUENCY RESPONSE: (New IHF Standard)

Main Amp Input: 20 Hz to 20,000 Hz; +0, -0.2 dB at rated power output
 2 Hz to 200,000 Hz; +0, -3.0 dB at 1 watt power output
 High Level Input: 20 Hz to 20,000 Hz; +0, -0.2 dB at rated power output
 Low Level Input: 20 Hz to 20,000 Hz; +0.2, -0.5 dB at rated power output

DAMPING FACTOR: (New IHF Standard) 50, at 50 Hz

INPUT SENSITIVITY AND IMPEDANCE:

| INPUT TERMINAL | SENSITIVITY | | IMPEDANCE OHMS |
|----------------|--------------|---------------------------------|-------------------|
| | RATED OUTPUT | New IHF Std. (1 watt output) | |
| Disc 2/MC | 0.09 mV | 0.011 mV | 100 |
| Disc 1/MM | 1.8 mV | 0.22 mV | 100, 47k, 100k |
| Aux., Tuner | 120 mV | 14.3 mV | 47k |
| Tape Play | | | |
| Main Amp Input | 0.95 V | 0.11 V | 47k |

MAXIMUM INPUT FOR DISC INPUT: (0.01% THD)

Disc 1/MM : 200 mV RMS at 1,000 Hz
 Disc 2/MC : 10 mV RMS at 1,000 Hz

OUTPUT LEVEL AND IMPEDANCE:

PREAMP. OUTPUT : 0.95 V at rated input level, 200 ohms
 TAPE REC. 1, 2 : 120 mV at rated input level, 200 ohms

HEADPHONE JACK:

for listening with low impedance (4 to 32 ohms) dynamic stereo headphones.

VOLTAGE AMPLIFICATION IN DECIBELS

MAIN AMP INPUT to OUTPUT: 27.8 dB
 HIGH-LEVEL INPUT to PREAMP OUTPUT: 18.4 dB
 DISC 1 INPUT to TAPE REC.: 36 dB
 DISC 2 INPUT to TAPE REC.: 62 dB

A-WEIGHTED SIGNAL-TO-NOISE RATIO:

| INPUT | RATED OUTPUT | New IHF Standard |
|------------------|--------------|------------------|
| Main Amp Input | 115 dB | 95 dB |
| High Level Input | 100 dB | 82 dB |
| Disc 1/MM | 77 dB | 80 dB |
| Disc 2/MC | 70 dB | 75 dB |

tone CONTROLS:

11-position Click-Stop type for both channels with turnover frequency switches and ON/OFF switch
 Bass: Turnover frequency 200 Hz; ±10 dB at 50 Hz
 Turnover frequency 500 Hz; ±10 dB at 100 Hz
 Treble: Turnover frequency 2,000 Hz; ±10 dB at 10 kHz
 Turnover frequency 7,000 Hz; ±10 dB at 50 kHz

LOUDNESS COMPENSATOR: (Volume attenuation at -30 dB)

COMP 1: +9 dB at 50 Hz
 COMP 2: +10 dB at 50 Hz, +6 dB at 20 kHz

SUBSONIC FILTER: 17 Hz cutoff 12 dB/oct.

ATTENUATOR: -20 dB

OUTPUT FOR SUB-WOOFER SYSTEM: (Monophonic)

OUTPUT LEVEL: +6 dB (with reference to PREAMP OUTPUT)
 CUTOFF FREQUENCY: 50 Hz, 70 Hz, 100 Hz and flat position
 CUTOFF SLOPE: -12 dB/oct.
 OUTPUT IMPEDANCE: 200 ohms

OUTPUT LOAD IMPEDANCE: 4 to 16 ohms

SEMICONDUCTOR COMPLEMENT: 52 Tr's, 14 ICs, 10 FET's, 23 Diodes

POWER REQUIREMENT:

Voltage selector for 100, 117, 220 and 240 V 50/60 Hz operation
 Consumption: 55 watts at zero signal output
 300 watts at rated power output into 8 ohms load

DIMENSIONS: 445 mm (17-1/2 inches) width, 128 mm (5-1/16 inches) max. height,
 370 mm (14-9/16 inches) depth

WEIGHT: 14.7 kg. (32.3 lbs.) net, 19.1 kg. (42.0 lbs.) in shipping carton

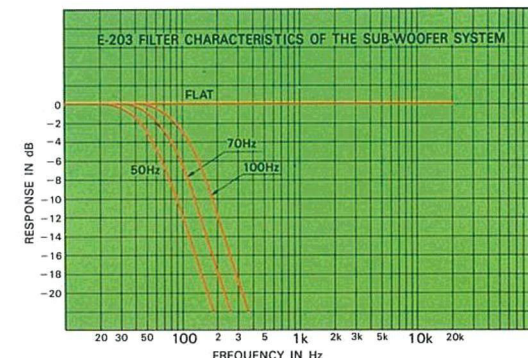
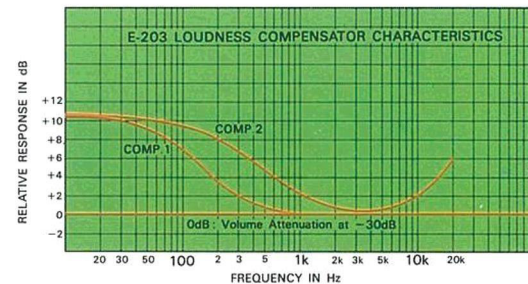
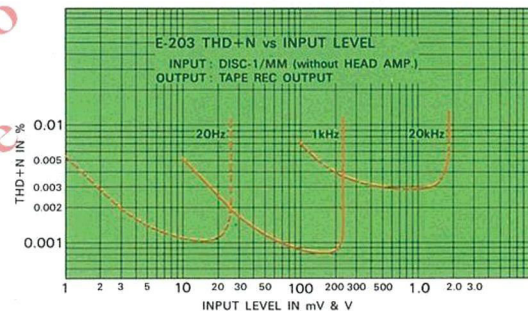
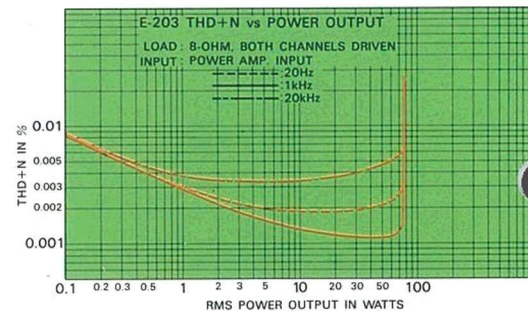
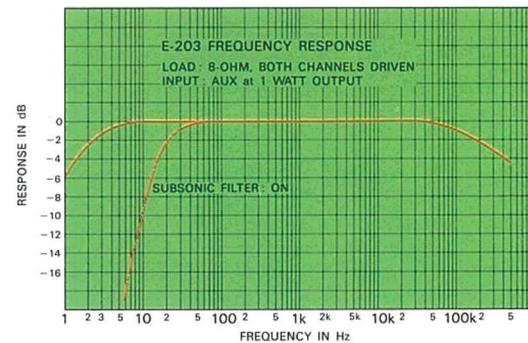

© beim Hersteller
 Archiv Michael Otto
 HiFi-Classics.de