

Accuphase

STEREO PREAMPLIFIER

C-280L

- All-stage cascode class A push-pull design and DC servo direct coupling
- Dual line amplifiers for balanced signal transmission
- Totally monophonic construction with two power transformers and Multiple Power Supply principle

Hersteller
Michael Otto

© beim Hersteller
Archiv Michael Otto



WITNESS THE ULTIMATE PREAMPLIFIER: ALL-STAGE CASCODE CLASS A PUSH-PULL DEDICATED VOLTAGE REGULATORS FOR EACH AMPLIFIER UNIT. IDEAL BALANCED

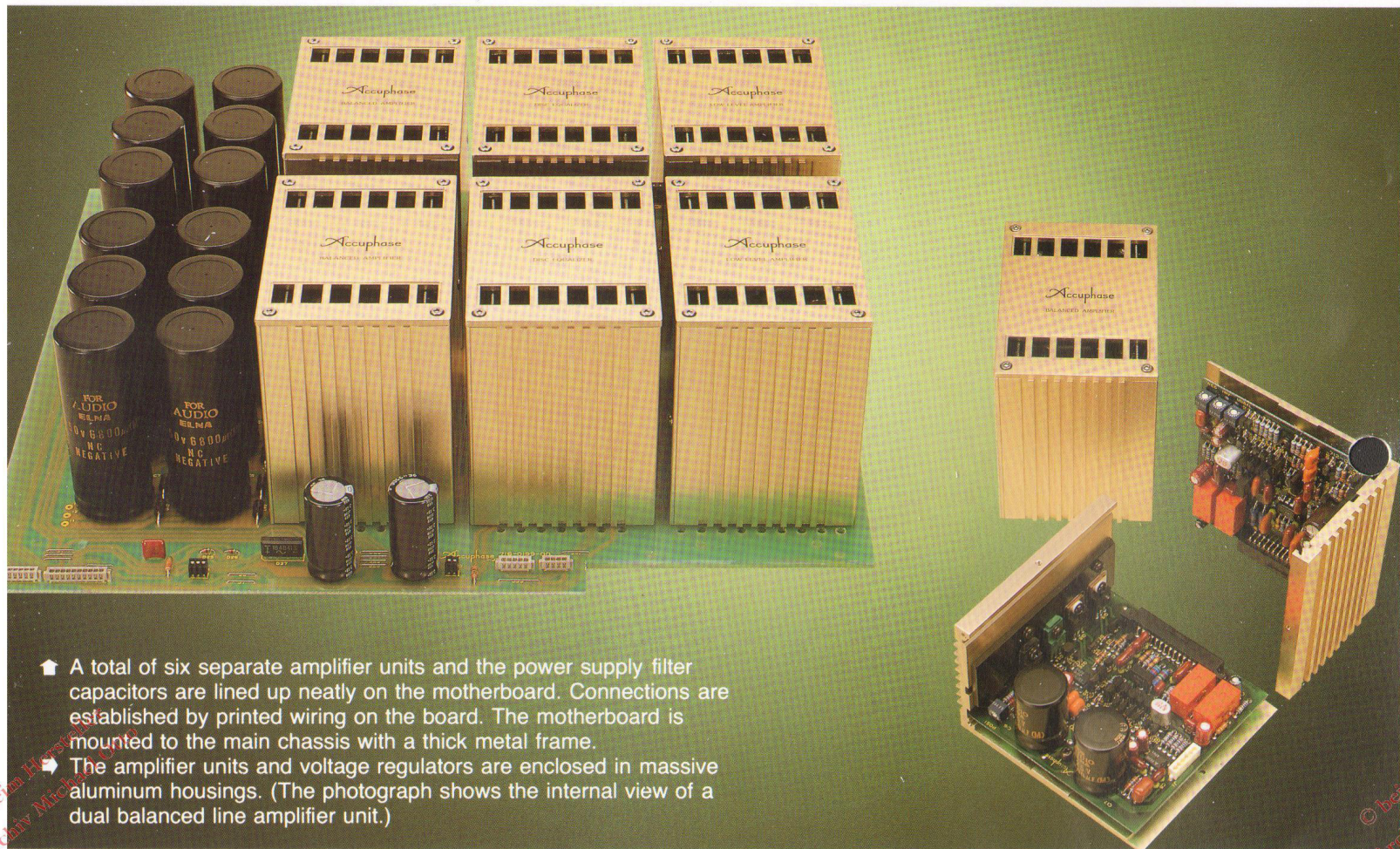

- ▶ A total of six separate amplifier units and the power supply filter capacitors are lined up neatly on the motherboard. Connections are established by printed wiring on the board. The motherboard is mounted to the main chassis with a thick metal frame.
- ▶ The amplifier units and voltage regulators are enclosed in massive aluminum housings. (The photograph shows the internal view of a dual balanced line amplifier unit.)

The Accuphase model C-280 which was introduced in 1982 has not only received the three main audio awards in Japan but has also been acclaimed the world over as one of the finest preamplifiers ever built. It is widely used as the ultimate reference for critical listening tests and it also has found its way into the homes of many discriminating music lovers. In the four years since its introduction, the audio world has been gradually progressing from analog to digital sources, and Accuphase is playing an important part in this development. We have now undertaken the challenging task to make the best even better and to introduce a further refined version of our top-of-the-line preamplifier. An important new aspect is the line amplifier configuration which now employs entirely separate units for ideal balanced signal transmission. The number of inputs has been increased to a total of ten including two balanced inputs. The phono stage including the MC head amplifier and equalizer circuits is the same as in the C-280, as it reflects many years of research and experience and represents the absolute state of the art developed by Accuphase. The principle of balanced signal transmission, which was propagated by Accuphase as early as 1980, has found its ultimate realization in the C-280L. Transcending the division between analog and digital, this preamplifier delivers nothing short of perfection for every application and program source. High-end music reproduction will never be the same.

In each channel, separate amplifier units and dual volume controls are used for each side of the balanced signal line. An entirely balanced system with ideal signal transmission characteristics throughout can be created by connecting equipment with balanced output to the input of the C-280L and using its balanced output for connection of the power amplifier. To fully preserve the purity and high quality of digital sources, the Line input has been refined to deliver unrivalled performance. Another highlight of the C-280L is its phono stage, which extracts even the most delicate nuances from analog records. Especially the MC head amplifier is designed to provide optimum conditions for cartridges with a wide range of impedances and output levels. Basically the C-280L consists of two monophonic amplifier blocks. This design effectively prevents mutual interference between the two channels. A total of six amplifier units are used, three for each channel, and each unit is enclosed in a thick aluminum housing, resulting in the best possible performance.

All amplifier stages employ the cascode-connected push-pull drive principle, for outstanding linearity up to very high frequencies and drastically improved signal-to-noise ratio. The original Multiple Power Supply developed by Accuphase delivers highly stable and ample current to each stage.

As the sound quality of an amplifier depends not only on its circuit topology but also on the basic quality of all devices and components, Accuphase has devoted extensive research efforts to each and every aspect, extending even to wiring and plating materials. The combined result of these efforts is utterly natural and pure music reproduction.

Externally, the amplifier presents an elegant and uncluttered appearance, with four main control knobs arranged in a symmetrical pattern and less used functions accessible by opening a sub panel. The massive cabinet made of exquisite persimmons wood also contributes to the visual appeal and high-quality feel of the amplifier which will continue to please its owner over many years of use.

1 **Balanced line amplifier with dual amplifier units for ideal signal transmission characteristics**

In professional audio applications, balanced signal transmission is extensively used, as this principle offers superior resistance against common-mode interference (noise). However, the transformers used in conventional systems tended to limit bandwidth and increase distortion. In the C-280L, newly developed balanced input circuits are employed and the hot and cold signals are amplified by separate amplifier units. This no-compromise approach assures ideal performance characteristics.

The block diagram of Fig. 1 shows the signal transmission principle of the C-280L. As two balanced inputs are provided, the input selector also is designed to switch the hot and cold lines separately. The same applies for the subsequent level control, where a total of four high-precision attenuators (two for each channel) are operating in conjunction. Each amplifier unit consists of two exactly identical circuits arranged in a complementary differential push-pull configuration for the ultimate in quality.

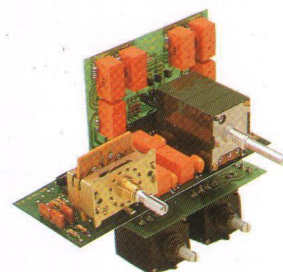

PULL DESIGN. TOTALLY MONOPHONIC CONSTRUCTION WITH TWO POWER TRACKED SIGNAL TRANSMISSION WITH DUAL LINE AMPLIFIERS.

2 All-stage cascode class A push-pull design for unsurpassed performance

The traditional Accuphase concept of all-stage class A push-pull amplification is of course also used in the C-280L, but it is complemented by a further refined cascode connection approach. In the load circuits, FET's are used instead of bipolar transistors, which eliminates any possibility of base current leakage and results in highly natural, uncolored sound quality.

Fig. 2 shows the basic cascode connection principle. The emitter or the source of transistor Q1 and the gate of transistor Q2 are grounded and the two transistors are connected in a vertical configuration. This results in very low input impedance at Q2 and total separation of input and output due to the grounding of the gate. These characteristics in turn assure outstanding linearity up to very high frequencies even before applying negative feedback. Also when applying global NFB, very stable operation is achieved.

Fig. 3 shows the circuit diagram of one side (either hot or cold) of the balanced amplifier. The topology at first glance may seem complicated, but basically the circuit consists of three stages: transistors Q1 to Q13 make up the differential amplifier, transistors Q14 to Q17 are the driver stage, and transistors Q18 to Q23 form the output amplifier stage. Complementary push-pull connection is used throughout. In this way, each device can perform to the best of its capabilities, and the symmetrical connection ensures even better overall results. All these benefits add up to assure minimum distortion and ideal amplification characteristics.

3 DC servo construction in all stages permits direct signal connection from MC input to output

The IC shown in Fig. 3 is the DC servo circuit which serves to detect any direct-current components in the output and feed them back to the input with reversed phase, thereby preventing DC drift. Although the total overall gain of the C-280L is a high 92 dB, this principle developed by Accuphase effectively eliminates DC drift and permits direct connection of all stages, from the MC input to the output terminals. This results in highly pure and natural sound reproduction.

4 Totally monophonic construction with two power transformers and separate voltage regulators for each amplifier unit

As the signal current constantly flows also through the power supply, this section may actually be regarded as part of the amplifier circuitry. Therefore the power supply must fulfill the same quality requirements as the other sections in order to achieve high overall performance. In the C-280L, each channel has its own power transformer, permitting completely monophonic construction. This ideal approach is further enhanced by the Multiple Power Supply principle, with a total of six separate voltage regulators for each amplifier unit, to achieve low power-supply impedance over a wide range.

Each amplifier unit and its voltage regulator are enclosed together in a thick aluminum housing and linked by the shortest possible connection. This effectively prevents a rise in power-supply impedance at high frequencies.

5 Logic-control relays for straight and short signal paths

Long signal paths are often thought necessary to accommodate functions such as input switching and tape monitoring. But the wiring runs tend to degrade high-frequency response, and direct handling of the signal by selector switches also causes problems regarding long-term reliability, as the contacts of such switches are adversely affected by air-borne smoke particles or contamination. In the C-280L, all switching is performed by relays which are arranged strategically so as to permit the shortest possible signal paths. These relays are controlled electronically by a logic circuit to assure accurate and precise operation.

The quality of the relays is also an essential consideration. In the C-280L, hermetically sealed relays filled with nitrogen gas are used, which were developed specifically for demanding audio or communications equipment. The contacts are twin crossbar types plated with gold or palladium alloy for minimum contact resistance and outstanding long-term reliability. To absolutely eliminate any possibility of sound degradation, low-level signals are switched by four parallel contacts.

6 Low-noise phono stage with strictly selected NFB circuit components

The basic circuit topology of the phono stage is similar to one side of the line amplifier section. As this stage has to handle low-level signals, the parts employed in the differential input stage are especially critical. In the C-280L, only ultra high quality components strictly selected for lowest inherent noise and flawless performance are used.

The quality of resistors and capacitors in the network which provides RIAA equalization also has a decisive influence upon sound quality. Silvered mica capacitors developed specifically for audio applications are used extensively in the C-280L. These capacitors are manufactured by a highly advanced method which involves the coating of high-quality mica with a silver layer by a screening process, and subsequent imprinting of a thin glass pattern. This increases the initial corona discharge voltage and ensures stable signal flow also with pulse-type high voltages. Even the connection of the lead wires has an influence on sound quality. In the capacitors selected for the C-280L, the wires are directly joined to the edge of the silver layer, so that absolutely no degradation occurs. In combination with high-precision handpicked resistors, this meticulous approach results in superior performance that manifests itself as utterly transparent and natural sound.

7 MC head amplifier with extremely low noise and wide dynamic range

Fig. 4 illustrates the circuit design of the MC head amplifier. While amplifying the extremely small signal levels of moving-coil cartridges, noise must be kept to an absolute minimum. To achieve this purpose, only the finest low-noise components are used and the impedance of the NFB loop is kept very low, resulting in a significant reduction of resistor-induced inherent noise. To prevent the intrusion of noise generated by the DC servo circuit, feedback is not connected directly to the negative side of the differential circuit but to the base of the constant-voltage transistors Q5 and Q6. This eliminates the noise interference from the servo circuit and results in excellent signal-to-noise ratio close to the theoretical limit.

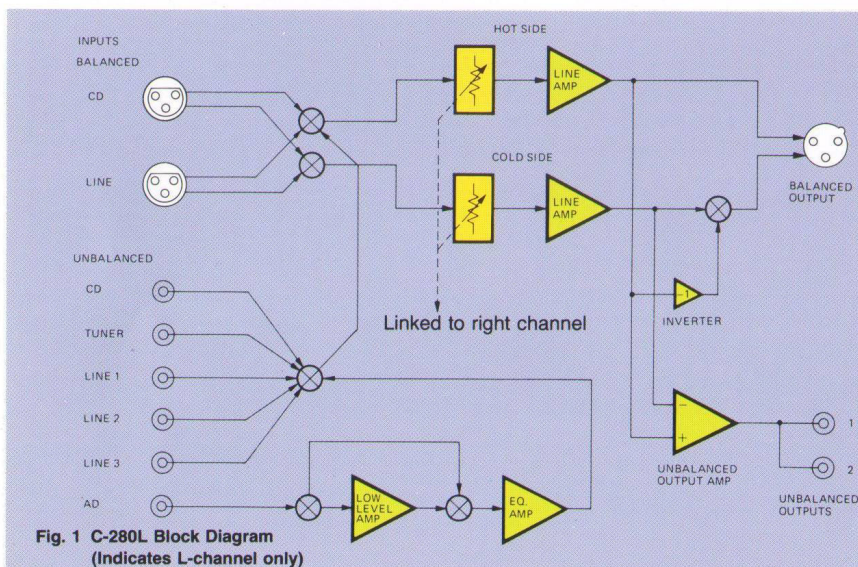

Fig. 1 C-280L Block Diagram (Indicates L-channel only)

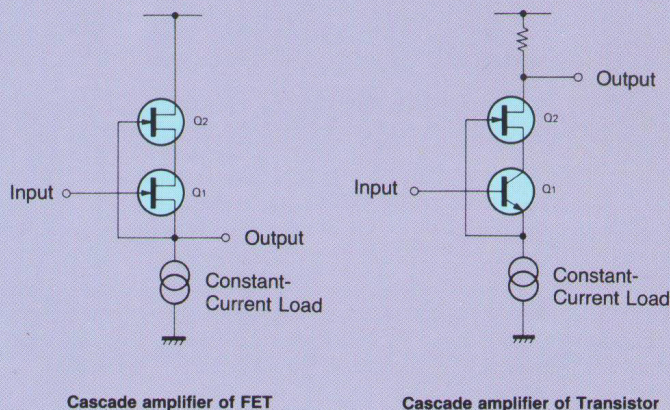

Fig. 2 Cascode Connection Circuit Principle

TRANSFORMERS.

Accuphase C-280L

STEREO PREAMPLIFIER

8

Versatile head amplifier input impedance and gain switching for optimum matching to a wide variety of MC cartridges

When using a head amplifier, matching of the cartridge's internal impedance to the input impedance is less critical than in the case of a step-up transformer. However, to extract optimum performance from the phono pickup, it is generally desirable to provide an adequately low input impedance for cartridges with low output impedance. The C-280L offers maximum flexibility, to accommodate any type of MC cartridge and precisely control the tonal balance. The MC input impedance can be switched in three steps to 10, 30, and 100 ohms. Cartridges with an internal impedance of about 3 ohms should be used at the 10-ohm or 30-ohm position and cartridges with about 10 ohms will perform best at the 30-ohm or 100-ohm position. For cartridges with very low output, the gain of the head amplifier can be increased from 26 dB to 32 dB.

The signal supplied by the cartridge reflects the RIAA recording equalization, which means a low-frequency cut and a high-frequency boost. The standard signal level at 20,000 Hz is actually about 20 dB (10 times) higher than the level at 1,000 Hz. Therefore the maximum input level of the head amplifier should be at least 50 mV. In the C-280L, an even greater overload margin is provided, with a full 150 mV assuring excellent dynamic range.

9

Massive aluminum housings for each amplifier/voltage regulator unit provide effective shielding and protection from resonances

Each of the six amplifier units, together with its dedicated voltage regulator, is enclosed in a thick aluminum housing. The circuit boards of each unit are securely screw-mounted and class A output devices as well as the voltage regulator components are directly joined to the housing for improved heat dissipation. Noise interference and adverse influences from vibrations are reliably shut out by this luxurious design.

10

Unsurpassed versatility with a total of 10 inputs and 5 outputs

A modern preamplifier must be able to accommodate a wide variety of input combinations. The C-280L is perfectly suited for this task, as it provides eight inputs using RCA-type phono jacks ÜCD, TUNER, AD (Analog Disc), 3 LINE inputs, 2 TAPE inputs, and two balanced inputs for CD and LINE. The output configuration includes two tape recording outputs, two preamplifier outputs using RCA-type jacks and one balanced output.

If soft plating materials are used for input and output jacks, the contact points will soon show wear and the base will be exposed. In the C-280L, special rhodium-finished jacks manufactured to strict Accuphase specifications are used exclusively. This type of coating is more expensive than gold-plating and is found mainly in high-priced computer and communications equipment. It ensures superior durability and corrosion-resistance. Although the coating is only 1 micron thick, it can withstand an amazing 100 million closure and breakage contacts. Contact resistance is also extremely low, ensuring reliable performance for an almost indefinite period.

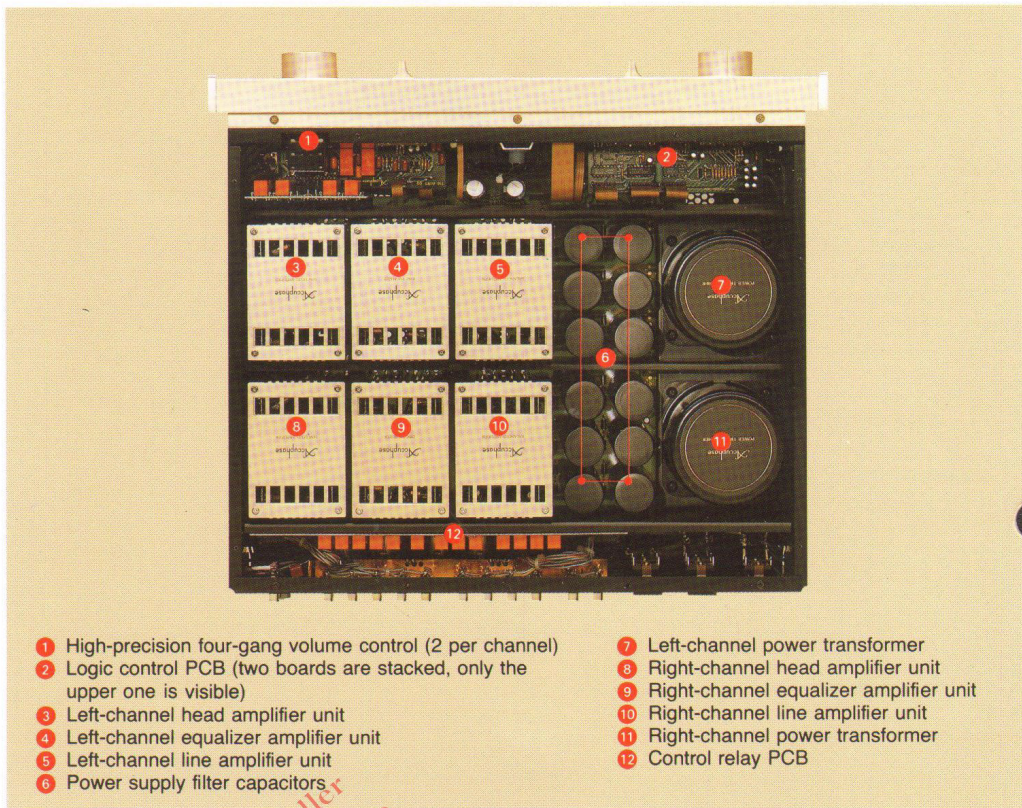

- 1 High-precision four-gang volume control (2 per channel)
- 2 Logic control PCB (two boards are stacked, only the upper one is visible)
- 3 Left-channel head amplifier unit
- 4 Left-channel equalizer amplifier unit
- 5 Left-channel line amplifier unit
- 6 Power supply filter capacitors
- 7 Left-channel power transformer
- 8 Right-channel head amplifier unit
- 9 Right-channel equalizer amplifier unit
- 10 Right-channel line amplifier unit
- 11 Right-channel power transformer
- 12 Control relay PCB

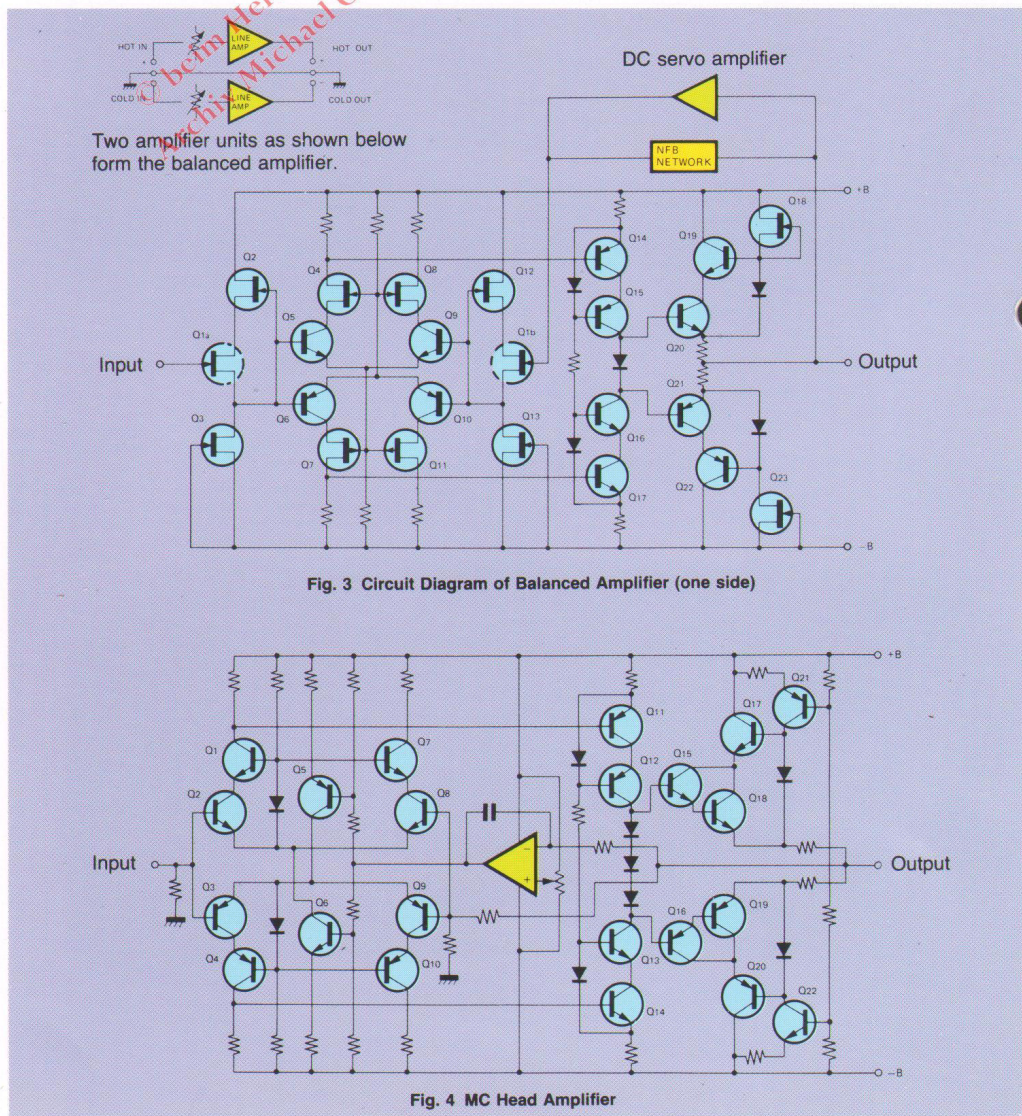

11

3-step rotary attenuator switch

When lowering the stylus onto a record, searching for a specific location on a disc, or in case of a sudden interruption such as a telephone call, it is most desirable to instantly reduce the listening volume by a fixed degree. The C-280L provides this convenience with a three-step attenuator switch. Turning this switch counterclockwise to "—" cuts off the sound altogether, while setting the switch to the "-20 dB" and "-30 dB" positions provides the indicated attenuation.

12

Highly precise adjustment of left and right output levels with separate left/right level controls

To compensate for signal differences or listening position and to adjust the level of each channel, the C-280L provides separate, highly accurate attenuators which operate in 0.5-dB steps to -6 dB and in 1-dB steps to -14 dB.

This permits well-defined and exact level settings.

13

Other features

To provide ideal facilities for tape recording and playback is another important aspect of preamplifier performance. The C-280L can accommodate two tape recorders with full monitoring. The lack of dynamic impact at very low listening levels is often a problem with preamplifiers that do not provide tone controls. Not so in the case of the C-280L: A loudness compensator can be used to restore proper sonic balance in accordance with the selected volume setting. Another useful feature for playback of analog records is the professional-quality subsonic filter. With its cutoff point of 10 Hz and slope of -18 dB/oct., the filter of the C-280L effectively removes harmful low-frequency noise components without affecting the musical signal.

14

Massive cabinet of natural persimmons wood

In the honored Accuphase tradition, the front panel of the C-280L is finished in brushed gold aluminum. The massive cabinet of exquisite persimmons wood further enhances the visual appeal of the amplifier, for a harmonious blend with the listening room.

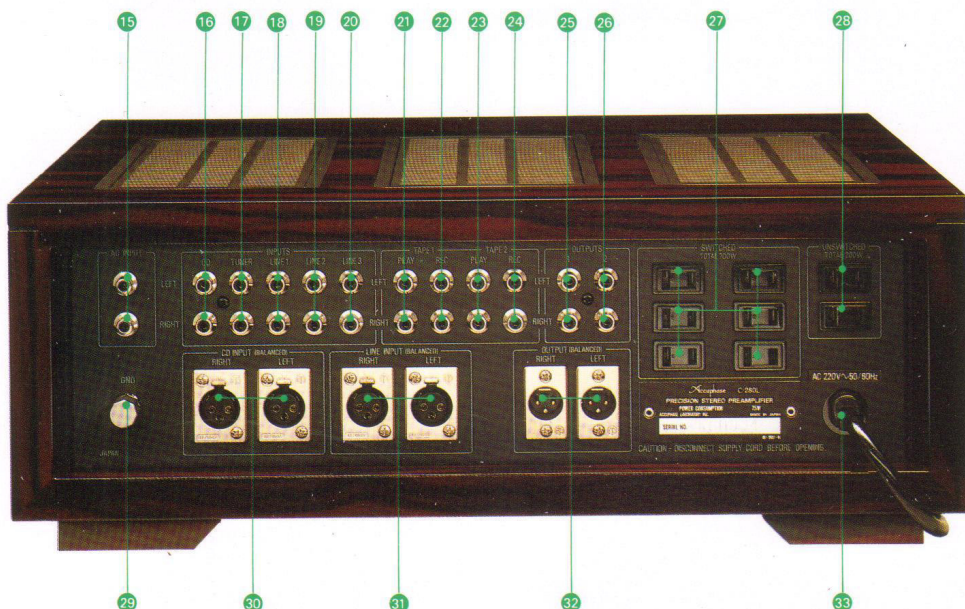
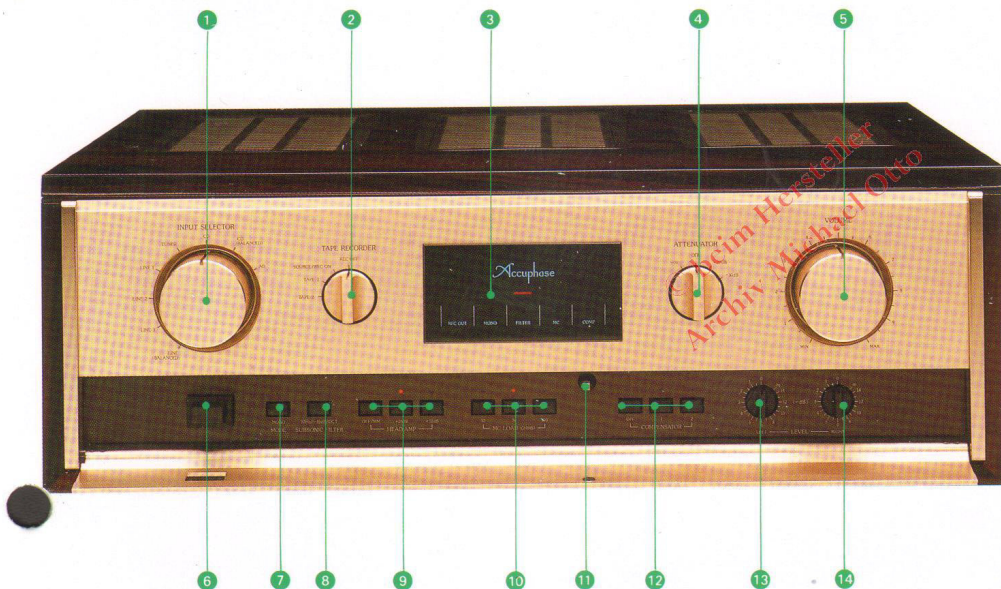

- 1 **INPUT SELECTOR**
LINE (BALANCED), LINE-3, LINE-2, LINE-1, TUNER, CD, CD (BALANCED), AD (Analog Disc)
- 2 Tape Monitor/Rec On/Off Selector
REC OFF, SOURCE/REC ON, TAPE-1, TAPE-2
- 3 Function Indicator LED's
Power ON/OFF, REC OUT On/Off, Stereo/MONO, FILTER On/Off, Head Amp ON(MC)/OFF, COMPensator On/Off
- 4 **ATTENUATOR**
-∞, OFF, -20 dB, -30 dB
- 5 **VOLUME** Control
- 6 Power Switch
- 7 Stereo/MONO Selector
- 8 **SUBSONIC FILTER**
10 Hz, -18 dB/OCT
- 9 MC Cartridge **HEAD AMP** On/Off Switch
- 10 MC Cartridge Input Impedance Selector
10, 30, 100 Ohms
- 11 Sub Panel Magnet Lock
- 12 Compensator Switch
OFF, 1, 2
- 13 **LEFT**-channel **LEVEL** Control
- 14 **RIGHT**-channel **LEVEL** Control
- 15 **AD**(Analog Disc) **INPUT** Jacks
- 16 Unbalanced **CD** Input Jacks
- 17 **TUNER** Input Jacks
- 18 **LINE 1** Input Jacks
- 19 **LINE 2** Input Jacks
- 20 **LINE 3** Input Jacks
- 21 **TAPE 1** Input Jacks
- 22 **TAPE 1** **REC**ording Output Jacks
- 23 **TAPE 2** Input Jacks
- 24 **TAPE 2** **REC**ording Output Jacks
- 25 **OUTPUT 1** Jacks (unbalanced/1 ohm)
- 26 **OUTPUT 2** Jacks (unbalanced/1 ohm)
- 27 AC Convenience Outlets (**SWITCHED**)*
- 28 AC Convenience Outlets (**UNSWITCHED**)*
- 29 Ground Terminal
- 30 **BALANCED CD** (CD) **INPUT** Connectors
XLR-3-31 type, for XLR-3-12C type plug (①: GND, ②: cold, ③: hot)
- 31 **BALANCED LINE** (LINE) **INPUT** Connectors
- 32 **BALANCED OUTPUT** Connectors
XLR-3-32 type, for XLR-3-11C type plug (①: GND, ②: cold, ③: hot)
- 33 AC Power Cord

* The switched and unswitched outlets may not be supplied depending on the safety standards or regulations applicable in the particular country to where the units destined.

GUARANTY SPECIFICATIONS

(Guaranteed specifications are measured according to EIA standard RS-490. AD denotes Analog Disc input.)

● **Frequency Response**

CD, TUNER, LINE, TAPE PLAY (UNBALANCED INPUT)
1.0 to 350,000 Hz +0, -3.0 dB
20 to 20,000 Hz +0, -0.2 dB
CD, LINE (BALANCED INPUT)
1.0 to 700,000 Hz +0, -3.0 dB
AD (UNBALANCED INPUT)
20 to 20,000 Hz +0, -0.2 dB

● **Total Harmonic Distortion**

0.005% (for all inputs)

● **Input Sensitivity, Input Impedance**

Input Terminal	Sensitivity		Impedance (Ohms)
	Rated Output	EIA (0.5V Output)	
AD (HEAD AMP OFF)	2.0mV	0.5mV	47k ohms
AD (HEAD AMP +26dB)	0.1mV	0.025mV	10/30/100 ohms
AD (HEAD AMP +32dB)	0.05mV	0.0125mV	10/30/100 ohms
CD, LINE, TUNER, TAPE	126mV	31.5mV	20k ohms
CD, LINE, BALANCED	126mV	31.5mV	40k ohms (20k/20k ohms)

● **Rated Output Level and Impedance**

OUTPUT (BALANCED):
2.0 V, 50 ohms (25 ohms/25 ohms)/XLR connector
OUTPUT (UNBALANCED):
2.0 V, 1 ohm/RCA-type phono jack
TAPE REC:
126 mV, 200 ohms/AD source/RCA-type phono jack

● **Signal-to-Noise Ratio**

Input Terminal	Rated Input	EIA
AD (HEAD AMP OFF)	90dB	86dB
AD (HEAD AMP +26dB)	78dB	76dB
AD (HEAD AMP +32dB)	72dB	76dB
CD, LINE, TUNER, TAPE	115dB	95dB
CD, LINE, BALANCED	115dB	95dB

● **Maximum Output Level**

(THD 0.005%, 20 - 20,000 Hz)
OUTPUT (BALANCED): 10.0 volts
OUTPUT (UNBALANCED): 10.0 volts
TAPE REC: 19.0 volts
(AD source)

● **Maximum Input Level (1 kHz, THD 0.005%)**

AD (HEAD AMP OFF): 300 mV
AD (HEAD AMP +26 dB): 15 mV
AD (HEAD AMP +32 dB): 7.5 mV

● **Minimum Load Impedance**

OUTPUT (BALANCED): 600 ohms (300 ohms/300 ohms)
OUTPUT (UNBALANCED): 1 kilohm
TAPE REC: 10 kilohms

● **Gain**

CD, TUNER, LINE, TAPE PLAY → OUTPUT: 18 dB
CD, TUNER, LINE, TAPE PLAY → REC OUTPUT: 0 dB
AD (HEAD AMP OFF) → OUTPUT: 54 dB
AD (HEAD AMP OFF) → REC OUTPUT: 36 dB

AD (HEAD AMP +26 dB) → OUTPUT: 80 dB
AD (HEAD AMP +26 dB) → REC OUTPUT: 62 dB
AD (HEAD AMP +32 dB) → OUTPUT: 86 dB
AD (HEAD AMP +32 dB) → REC OUTPUT: 68 dB
UNBALANCED INPUT → BALANCED OUTPUT: 24 dB

● **Loudness Compensator Characteristics (volume setting -30 dB)**

1: +3 dB (100 Hz)
2: +8 dB (100 Hz), +6 dB (20 kHz)

● **Subsonic Filter Characteristics**

Cutoff frequency 10 Hz, -18 dB/oct.

● **Attenuator Characteristics**

-20 dB, -30 dB, infinite

● **Semiconductor Complement**

219 transistors, 58 FET's, 26 IC's, 174 diodes

● **Power Requirements**

Voltage Selection for 100, 117, 220, 240 V, 50/60 Hz operation

● **Power Consumption**

75 W

● **Dimensions**

468 mm (18-7/16 inches) width,
171 mm (6-12/16 inches) max. height,
396 mm (15-9/16 inches) depth.

● **Weight**

18.1 kg (39.9 lbs) net, 23.1 kg (50.9 lbs) in shipping carton.

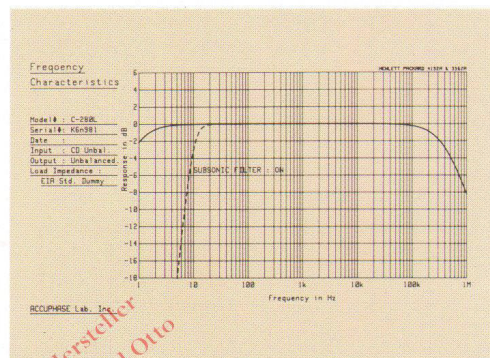

● **Frequency response**

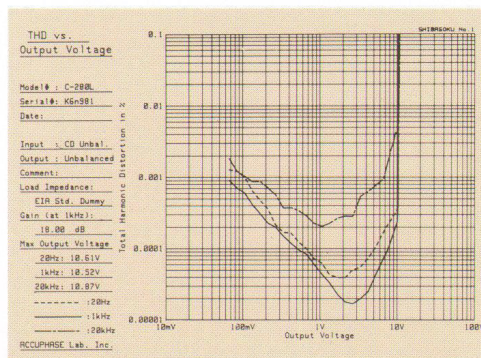

● **Output Voltage vs. THD (Unbalanced CD input to unbalanced output)**

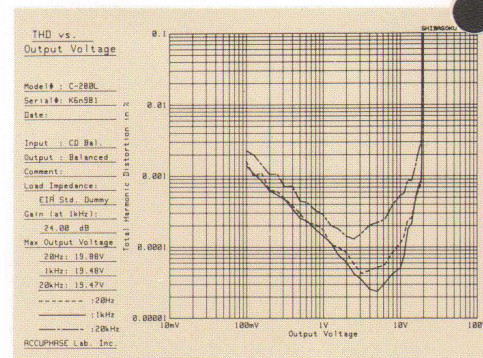

● **Output Voltage vs. THD (Balanced CD input to balanced output)**

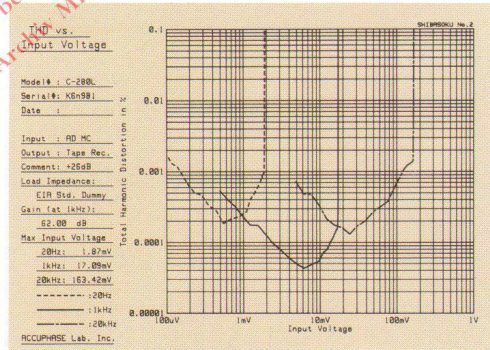

● **Input Voltage vs. THD (MC input to tape recording output)**

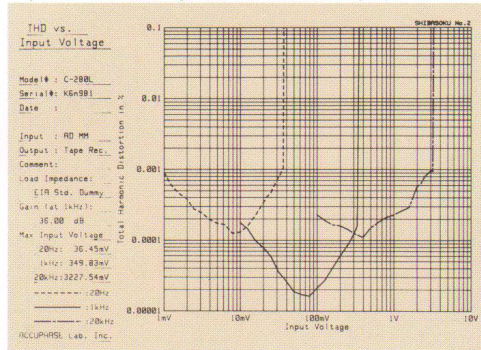

● **Input Voltage vs. THD (MM input to tape recording output)**

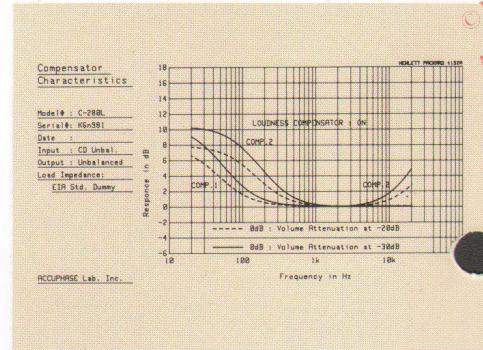

● **Loudness Compensator**

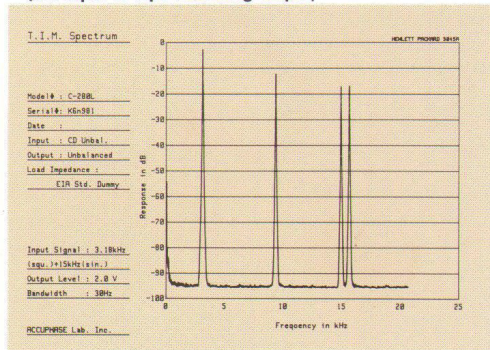

The graph on the left shows the transient intermodulation distortion (TIM) spectrum. To measure this parameter, a square wave of 3.18 kHz and a sine wave of 15 kHz are mixed and supplied to the input. The square wave signal contains almost unlimited odd-number higher harmonics, with components at 9.54 kHz (third harmonic), 15.9 kHz (fifth harmonic), etc. When these components intermodulate with the 15-kHz signal, modulation products show up at frequencies where there is no input signal, for example at 5.46 kHz (15 kHz - 9.54 kHz). As the graph confirms, there are no distortion products at all above -93 dB, which means that TIM is less than 0.0022%.

