

Accuphase

STEREO PREAMPLIFIER

C-280

Hersteller
Michael Otto
Classic.de

© beim Hersteller
Archiv Michael Otto
HiFi-Classic.de



The advent of Compact Discs (CD), a new type of disc program source, has raised the question of how they will compare in sound quality with conventional discs that are based on the analog system. The latter with its accumulated technology of a hundred years displays a remarkably high standard in storing music and musical atmosphere, the quality of which seems recently to be limited only by the ability of the sound reproduction system employed to unlock its full potential. Beyond a doubt, the near future will see keen competition between the two types of disc sources to determine which will be recognized eventually as superior from the high fidelity standpoint.

Meanwhile, audiophiles of audio reproduction systems now have a further incentive to develop new techniques to continue improving music reproduction technology.

It is to meet this need of the times that the Accuphase C-280 Pre-amplifier was developed. The main objective was to build a preamplifier capable of preamplifying highest quality music reproduction signals from both analog and digital discs, and also to reveal the individuality of turntables, tape recorders and speakers in a straightforward manner. Accuphase technology was thus concentrated on recreating musical nuance signals in greater detail, and providing an added sense of reality to musical reproduction. A total of six unit amplifiers, three for each channel, are perfectly separated by a twin mono-construction system. Furthermore, each unit amp is housed separately, and is effectively shielded to produce superb, undistorted amplified signals.

The tone control was eliminated to keep functions as simple as

possible. Only an irreducible minimum of function controls were retained.

For the first time in the world, cascode push-pull amplification is employed in every stage to achieve superior high frequency characteristics and greatly improve linearity and signal-to-noise ratio. Also an ideal multiple power supply system is used to provide each unit amplifier with its exclusive power supply. This has ensured low impedance over a wide range and superior amplification characteristics.

All devices that could affect sound quality were meticulously chosen, and, where necessary, specially developed to ensure maximum sound purity. Even wiring schemes and special plating for input/output terminals were not neglected. The quality of line input was another area given extra attention. Thus, the C-280 was most carefully created to preamplify both digital and analog discs and feed the best signal characteristics to subsequent amplifiers.

The C-280 also provides better impedance matching for MC (moving-coil) phono cartridges. It also provides head amp gain adjustment to cope with wide variations in MC cartridge output levels.

The front panel has four main function control knobs that are arranged symmetrically, while lesser function controls are found in the sub-panel.

The C-280 is enclosed in a handsome and impressive persimmon wood cabinet. The elegant appearance and dignified simplicity in design will persuade owners to cherish it for many years.

Accuphase firmly believes the C-280 will provide the vista to dimensions in musical reproduction.

1 CASCODE CLASS-A PUSH-PULL AMPLIFIER LINEUP GREATLY IMPROVES HIGH FREQUENCY, LINEARITY and SIGNAL-TO-NOISE CHARACTERISTICS

An amplifier's basic characteristics are largely determined by its circuit configuration. In this sense, its circuit makeup is the most important factor.

The C-280 incorporates cascode amplification in addition to Accuphase's traditional use of Class-A Push-Pull Amplifiers in every stage. This has further improved desirable amplifier characteristics to the utmost limits before NEB (Negative Feedback) application.

Figure 1 shows the basic circuit of the cascode scheme used in the C-280 in which the common emitter amp Q1 and common base amp Q2 are connected in series. The low input impedance of common base Q2 ensures low output impedance and stabilizes operation. On the other hand, Diode D regulates voltage and functions as bootstrap circuit advantages which allow input impedance increases, and preserves high gain and stable operation without distortion.

The cascode circuit's distinctive features are low feedback and excellent high frequency characteristics. It is an ideal amplifier since it provides linearity over a device's entire operating range, reduces distortion and improves signal-to-noise ratio. Moreover, the employment of Class-A Push-Pull amplifiers in every stage further improves the C-280's basic circuit characteristics of linearity and low distortion before NFB is applied.

Figure 2 shows the basic diagram of the unit amplifier. The same circuit is used throughout for the head amplifier, the equalizer amplifier and the high level amplifier. Though appearing complex at first glance, it is basically three stages of amplification. The eight devices from Q2 to Q9 make up the cascode push-pull differential amplifier stage, while Q11 Q12, Q14 Q15 on the one hand, and Q16 to Q19 are cascode push-pull amp circuits, respectively. Combined they form a simple amplification configuration of three stages that achieve maximum purity and stability of amplified signals.

2 DC SERVO CONTROL IN ALL UNIT AMPS PERMIT STRAIGHT DC OPERATION FROM MC INPUT TO FINAL OUTPUT

The IC in Figure 2 is the DC Servo Control circuit which eliminates DC drift by backfeeding to the input any DC current that may appear at its output. The C-280 achieves a total maximum gain of 92 decibels. Yet, all its signal paths from the MC input to the final output are directly coupled from one stage to the next in a straight DC operation. This big advantage is possible because DC drift is completely eliminated by the elaborately designed, effective DC Servo control circuits. So there is a good reason for the high quality sound characteristics that carry no trace of coloration.

3 TWIN MONO-CONSTRUCTED INDEPENDENT POWER TRANSFORMERS; EACH UNIT AMPLIFIER HAS ITS EXCLUSIVE POWER SUPPLY

The power supply can be considered a part of the amplifier circuit

since signals also pass through it. Therefore, unless its quality matches that of the amplifier circuit, no improvement in overall sound characteristics can be realized.

The C-280 employs twin power transformers which are both completely independent, electrically and structurally, of each other. One energizes the left channel and the other the right channel. Furthermore, to achieve low impedance over a wide bandwidth, this preamplifier employs an extravagant multiple power supply system consisting of six independent constant voltage power supplies, one for each of the unit amps.

Figure 3 shows such a power supply for the equalizer amp unit. Q9 Q10, Q13 Q14, Q11 Q12 and Q15 Q16, respectively make up high gain, cascode differential amplifiers which ensure constant supply voltages. The unit amps and their exclusive power supplies are mounted in heavy aluminum housings. Shortest signal path leads are used to prevent increase of power supply impedance at the high frequencies.

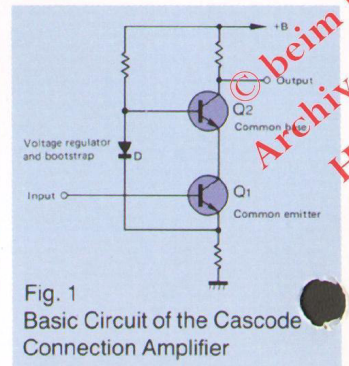

Fig. 1 Basic Circuit of the Cascode Connection Amplifier

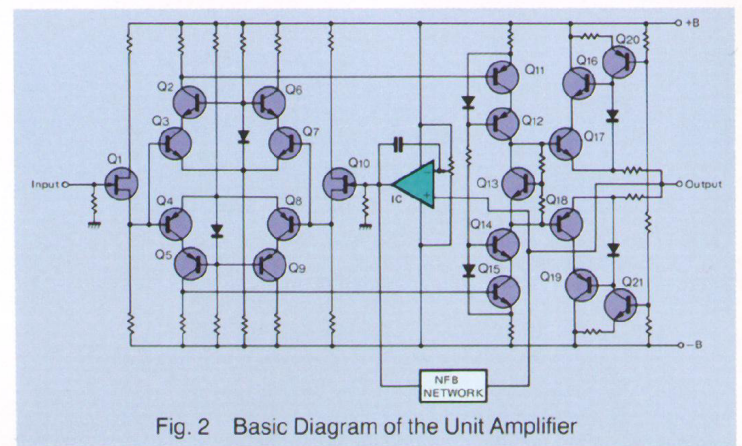
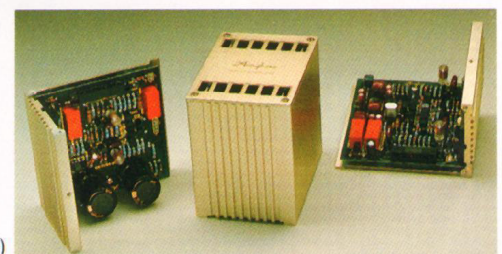
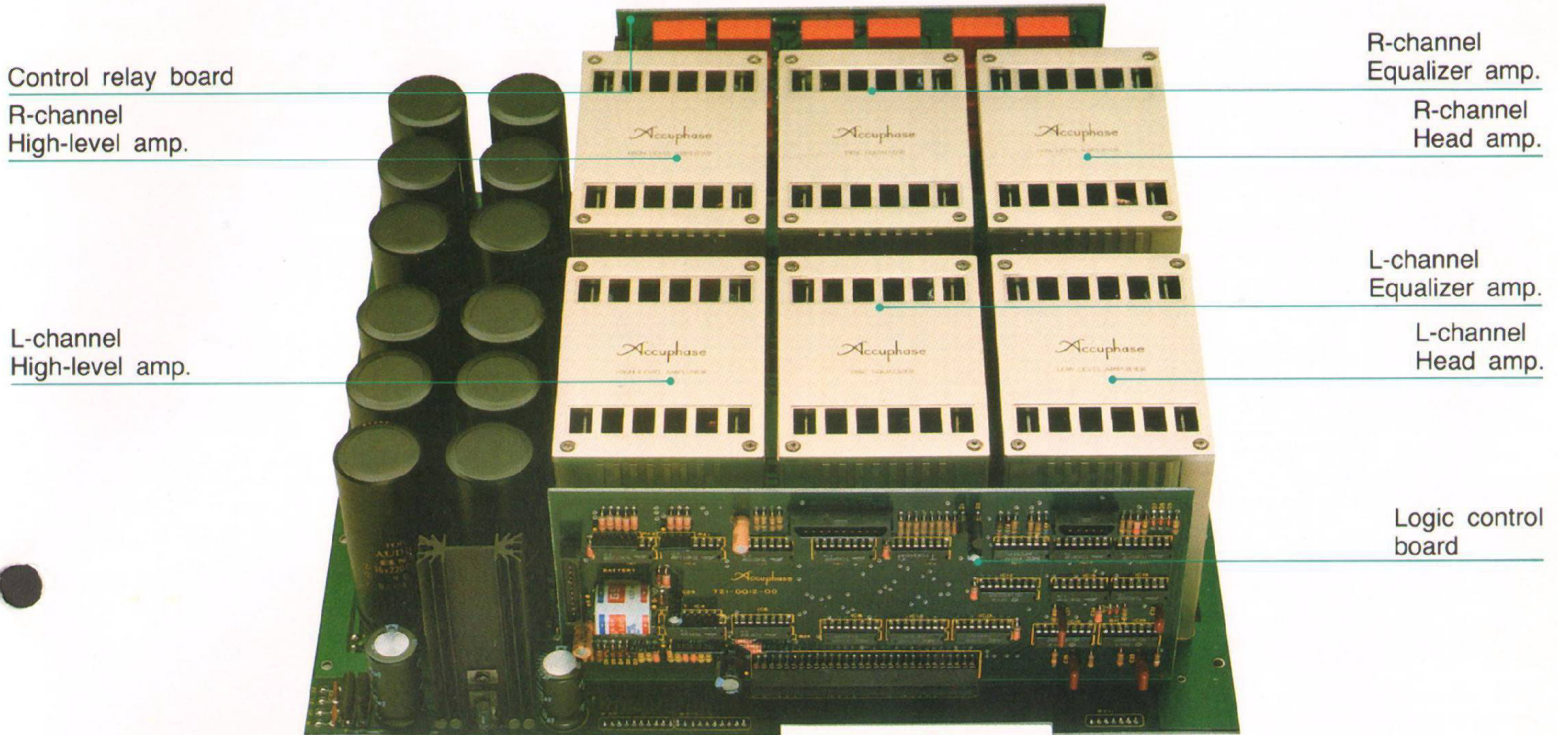

Fig. 2 Basic Diagram of the Unit Amplifier



● Unit Amplifier (High-level Amplifier)



● Unit Amplifiers and Logic Control Board on the Motherboard

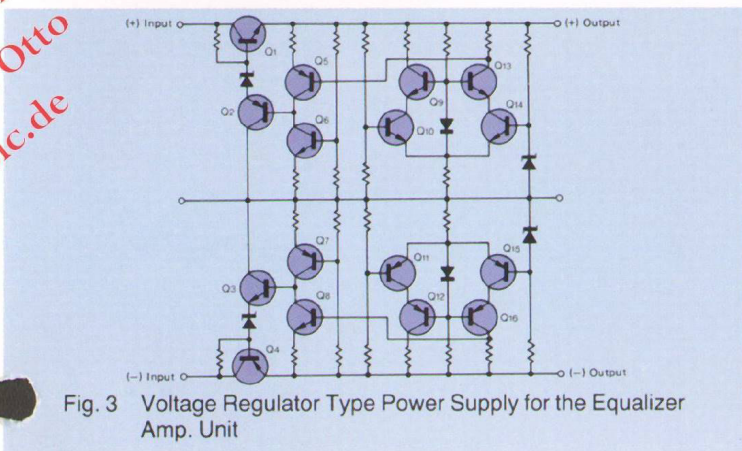

Fig. 3 Voltage Regulator Type Power Supply for the Equalizer Amp. Unit

4 LOGIC CONTROL RELAYS USED TO SHORTEN SIGNAL PATHS

Long signal path leads necessitated by switching connections for program selection, tape monitoring, etc., are liable to induce unstable factors that deteriorate high frequency signal quality. To avoid this, the C-280 employs logic control relays that electronically control switching and permit straightest, shortest signal input leads.

Obviously, the quality of relays becomes a key point in such a system so this preamplifier uses the best. They are specially developed audio and communication relays that are sealed inside pressurized nitrogen gas housings. Their contact points are either gold-plated or silver palladium alloy-plated in the case of twin-crossbar contact relays. They ensure minimum contact resistance and long-term stability which is further secured by provision of four contact points in parallel wherever low level signals must pass.

5 LOW NOISE EQUALIZER AMP DUE TO SPECIALLY SELECTED NFB AND RIAA NETWORK COMPONENTS

The special features of the equalizer amplifier circuit shown in Figure 2 were described under Section 1 above. It must be stressed here, however, that the quality of components can also greatly affect sound quality, and it is here again that Accuphase products receive extra attention in design and production.

For example, the devices used in the input stage of the differential amplifier are most rigidly selected for low noise characteristics. Also the

devices, resistors and capacitors that make up the RIAA network characteristics are just as important as the circuitry in determining the final sound.

Especially important are the capacitors. Therefore, highest quality silvered mica capacitors, specially developed for audio, are used. They are made from selected, high purity mica sheets and (thin silvered film) with a special technique utilizing glass pattern printed technology. They allow a higher corona discharge voltage which in turn increases amplifier capability to handle larger input pulse signals without distortion and greater stability.

Possible deterioration of sound quality from high resistance connections has also been given careful attention and thoroughly eliminated. The connecting tips of all signal carrying leads that affect sound are thinly silver-coated to ensure permanent solid connections.

Resistors too were most rigidly selected. This extra attention to component selection, etc., has endowed the C-280 with clearest, transparent sound producing characteristics that is free of coloration.

6 WIDE DYNAMIC RANGE, EXCLUSIVE HEAD AMPLIFIER PROVIDED FOR MC (Moving Coil) PHONO CARTRIDGES

A flat characteristic, exclusive head amplifier for MC Phono cartridges is placed before the equalizer amplifier, instead of merely a system to raise the gain in the latter.

Figure 4 shows the head amplifier circuit. Since it must accommodate very low level signals, priority was given to prevent circuit noise. For example, resistor noise was greatly suppressed by using low noise devices in the input circuits, and also by securing low impedance in the NFB loop.

Adverse effects of DC Servo Control circuit noise were practically eliminated by backfeeding DC drift voltage to the bases of the constant current devices Q5 Q6, rather than directly to the inverting input of the differential amplifier. As a result, an excellent signal-to-noise characteristic close to the theoretical limit was obtained.

7 IMPEDANCE AND GAIN SELECTORS ENSURE BEST INPUT MATCHING

The C-280 is provided with excellent input matching to various MC cartridges which come in such wide variations of impedances and output levels. For example, output impedances of MC cartridges vary all the way from 2 ohms to almost 50 ohms, a difference of 20 or 30 times. Likewise, their output voltage levels vary from 0.01 mV to 0.5 mV, a difference of 50 times (34 dB). Although matching MC cartridges to the head amplifier is not as critical as for transformer coupling, low output

impedance cartridges should be coupled to low input impedance to obtain best performance.

To accommodate this wide variety of MC cartridges and preserve fine control of sound quality, the C-280 provides a choice of input impedance of 10 ohms, 30 ohms or 100 ohms.

This permits coupling MC cartridges of about 3-ohm impedance to a load of 10 ohms or 30 ohms, and cartridges of over 10-ohm impedance to either a load of 30 ohms or 100 ohms for closer matching.

Also to accommodate MC cartridges with very low output levels, a Gain Selector switch in the C-280 raises the gain to 32 dB instead of the normally operated head amp gain of 26 dB.

Signal input levels to the head amplifier are based on RIAA recording characteristics that drop in the low frequencies and rise in the high frequency range. A signal at 20,000 Hz would be about 20 dB, 10 times that of a signal at 1,000 Hz. Therefore, the maximum input level of head amplifiers must extend at least to a level of 50 mV. Extension is provided up to 150 mV in the C-280 and this wide dynamic range gives it ample margin to handle any input pulse signal voltages.

8 600-OHM BALANCED TYPE OUTPUT CONNECTOR FOR LOW NOISE LONG CABLE CONNECTIONS

The use of a 600-ohm balanced type cable network has long been a standard practice by broadcasting stations, and also for commercial audio applications when long signal carrying cables are required, since it effectively prevents noise pickup. The C-280 is equipped with an output connector for connecting such balanced cables.

The principle is shown in Figure 5 in which equal positive and negative signal voltages in relation to ground potential are transmitted by the balanced cable network. Even if unwanted disturbances are picked up by the cable, the positive and negative noises appear in the same phase and are effectively cancelled out by a phase inverter circuit in the input stage of the power amplifier. In short, such a balanced line prevents noise pickup and ensures minimum deterioration of signal sound quality from long cable connections. However, the components on both sides must be equipped with 600-ohm balanced type cable connectors.

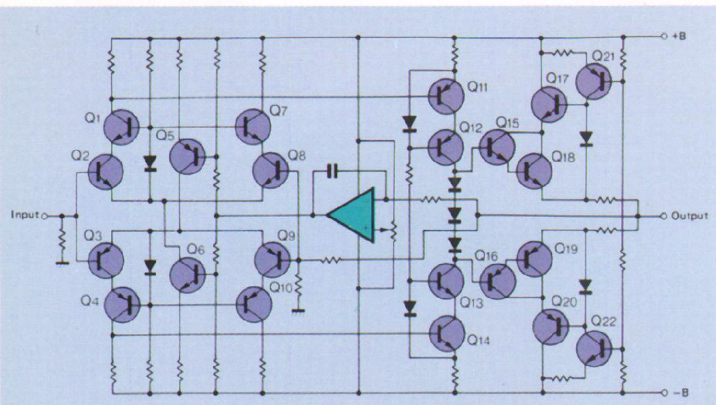

Fig. 4 Circuit Diagram of the Head Amplifier

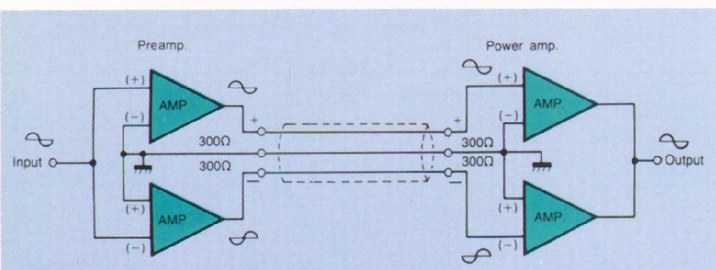
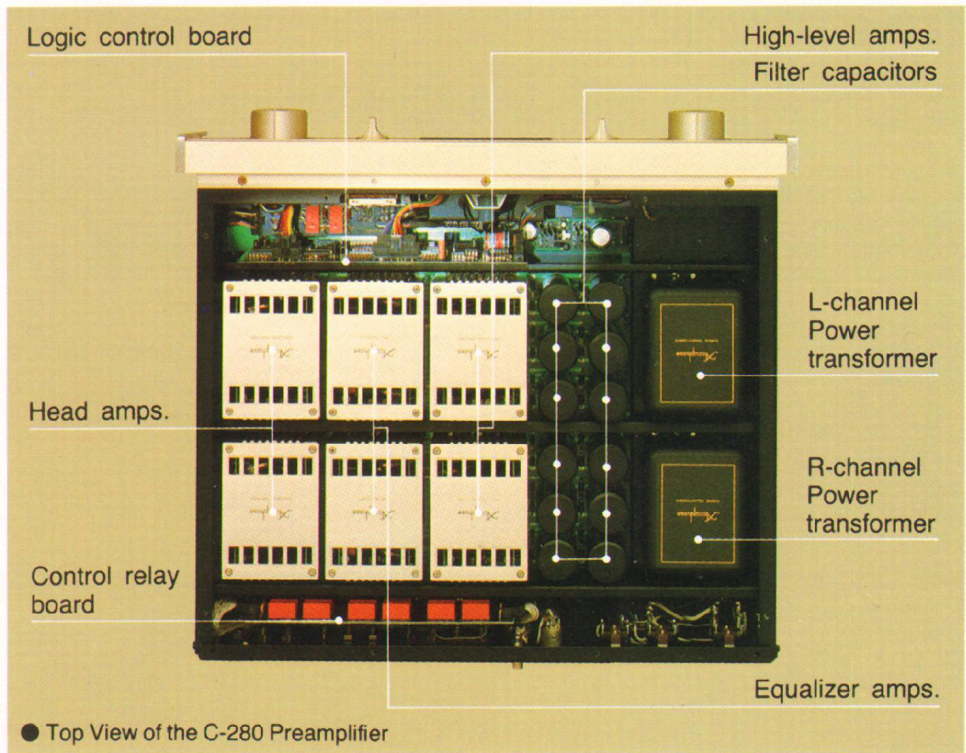

Fig. 5 Principle of the Balanced Type Network



● Top View of the C-280 Preamplifier

9 ALL UNIT AMPLIFIERS HAVE EXCLUSIVE POWER SUPPLIES

The six unit amps in both the left and right channels have their exclusive constant voltage power supplies, respectively, and are mounted and housed in their own aluminum blocks. Good heat dissipation for Class-A output and power supply devices is provided for, and printed circuit boards are firmly mounted within. The unit amps are thus very well shielded and protected against electrical resonance from vibrations.

10 COMPLETE TAPE RECORDING FUNCTIONS

Although priority was given to disc preamplification, the recording and reproduction of tapes were not overlooked in that the C-280 provides connection to two tape recorders for all possible functions of recording, playback and monitoring.

11 3-STEP ROTARY TYPE ATTENUATION

An attenuation control is convenient when starting off record play, searching for tape positions, or temporarily muting volume level when answering the phone. The C-280 has a 3-step rotary type attenuator switch which, when turned counterclockwise to the $-\infty$ position, turns volume completely down. When turned clockwise, it reduces volume by -20 dB at the first step and further by -30 dB at the next position.

12 INDEPENDENT LEVEL CONTROLS FOR EACH CHANNEL

Independent level controls, one each for the left and right channels, are provided so that stereo balance can be easily adjusted for any listening position. These controls permit attenuation from 0 to -6 dB in 0.5 dB steps and further attenuation down to -14 dB in 1 dB steps.

13 EFFECTIVE SUBSONIC FILTER CUTS OFF HARMFUL INFRASONIC NOISE AT 10 Hz WITH -18 dB/Oct ATTENUATION SLOPE

A -18 dB/oct attenuation slope filter is provided to cut off subsonic noise below 10 Hz without affecting the audio frequency range. The undesirable interference around 2 Hz caused by warped record can be attenuated by about 40 dB comparing to audible signals. This unwanted vibrational energy is reduced to 1/10,000 of its original strength by this filter.

14 LOUDNESS COMPENSATOR MAINTAINS ACOUSTIC BALANCE AT LOW LISTENING LEVELS

Although the C-280 has no tone control, automatic loudness compensation determined by the setting of its volume control is another one of its features.

At low listening levels, this provision boosts the volume of lower frequency range sounds to make up for the deficiency of human hearing to detect their true volume. In other words, it provides loudness compensation to make up for the increasing imbalance of bass tones heard by the ear as volume is turned down. It thus maintains audible sound balance when listening at low volume levels.

The C-280 offers a choice of two loudness compensation curve characteristics by switch selection.

15 RHODIUM FINISHED HIGH QUALITY INPUT/OUTPUT JACKS

It is important to avoid soft plating materials in finishing often-used input/output jacks as their contact points may soon show wear and expose the substrate. This eventually leads to corrosion and the undesirable effects of poor contact.

The very high quality jacks used in the C-280 have been rhodium-plated, and are employed for the first time in audio amplifiers. Rhodium-plating, which is more expensive than gold-plating, is adopted for its superior durability in computer and communication equipment connectors. It has a superior hardness quality that gives it long wearing qualities. A 1 μm -thick coating can withstand 100 million circuit closure and breakage contacts. Rhodium-plating also has superior anti-corrosive qualities and ensures reliable contacts almost permanently.

16 ELEGANT APPEARANCE

The C-280 with its elegant golden finished panel is an impressive looking instrument, especially as it is encased in a beautiful persimmon finished wooden case, which adds dignity and decor to any listening room.

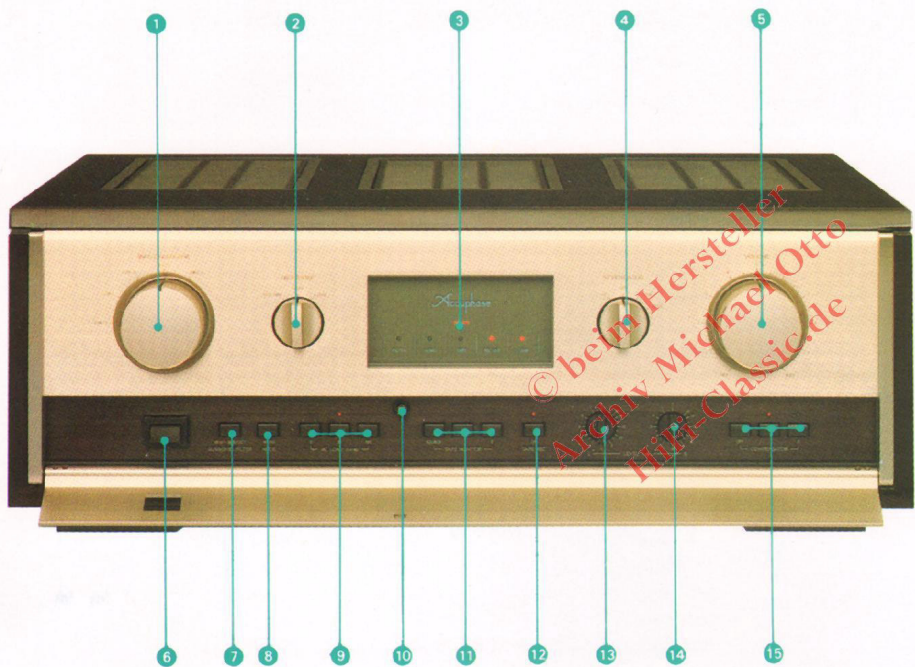

- 1 **INPUT SELECTOR**
LINE 2, LINE 1, TUNER, DISC 1, DISC 2
- 2 **HEAD AMP selector**
OFF/MM, +26 dB, +32 dB
- 3 **Power ON/OFF and muting circuit operation indicators (LED)**
- 4 **ATTENUATOR**
-∞, OFF, -20 dB, -30 dB
- 5 **VOLUME level control**
- 6 **POWER switch**
- 7 **SUBSONIC FILTER**
10 Hz, -18 dB/oct
- 8 **MODE switch**
MONO/STEREO
- 9 **MC LOAD selector**
10, 30, 100
- 10 **Magnet catch for subpanel**
- 11 **TAPE MONITOR control**
SOURCE 1, 2
- 12 **ON/OFF switch of TAPE REcording output**
- 13 **L-channel LEVEL control**
- 14 **R-channel LEVEL control**
- 15 **Loudness COMPENSATOR**
OFF, 1, 2

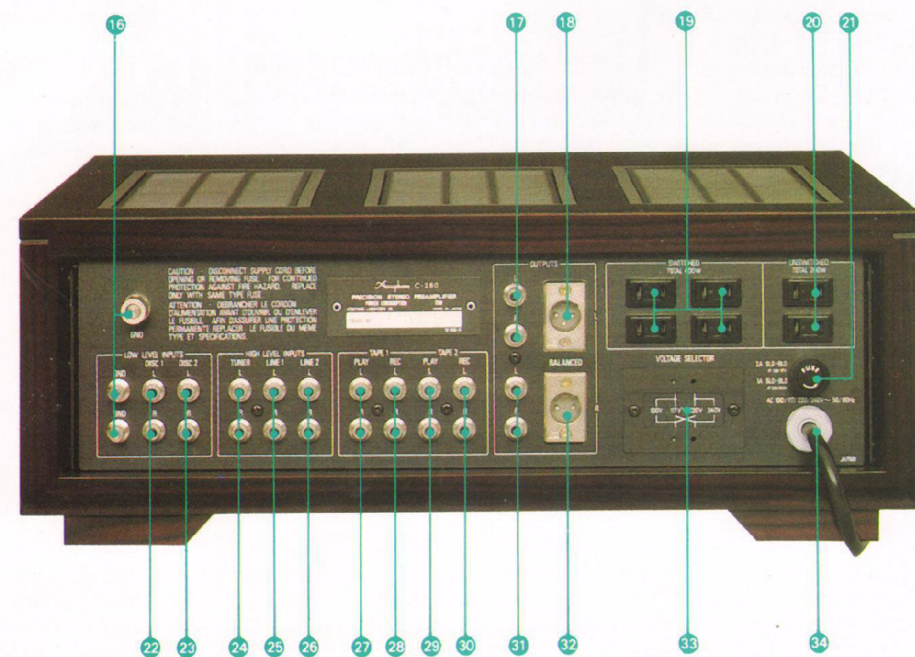

- 16 **GROUND terminals**
- 17 **OUTPUT jacks (unbalanced)**
- 18 **L-channel XLR type connector (BALANCED output)**
- 19 **AC outlets (SWITCHED)**
- 20 **AC outlets (UNSWITCHED)**
- 21 **AC line FUSE holder**
- 22 **DISC 1 LOW LEVEL INPUTS**
- 23 **DISC 2 LOW LEVEL INPUTS**
- 24 **TUNER HIGH LEVEL INPUTS**
- 25 **LINE 1 HIGH LEVEL INPUTS**
- 26 **LINE 2 HIGH LEVEL INPUTS**
- 27 **TAPE 1 PLAYback input jacks**
- 28 **TAPE 1 REcording output jacks**
- 29 **TAPE 2 PLAYback input jacks**
- 30 **TAPE 2 REcording output jacks**
- 31 **OUTPUT jacks (unbalanced)**
- 32 **R-channel XLR type connector (BALANCED output)**
- 33 **VOLTAGE SELECTOR**
- 34 **Power cord**

GUARANTY SPECIFICATIONS

● **PERFORMANCE GUARANTY**

All Accuphase product specifications are guaranteed as stated

● **FREQUENCY RESPONSE**

TUNER/LINE/TAPE PLAY INPUT
 1 Hz to 500,000 Hz +0, -3.0 dB
 20 Hz to 20,000 Hz +0, -0.2 dB
 DISC INPUT:
 20 Hz to 20,000 Hz ±0.2 dB

● **TOTAL HARMONIC DISTORTION (New IHF Standard)**

Will not exceed 0.005% at rated output level, 20 Hz to 20,000 Hz

● **INPUT SENSITIVITY AND IMPEDANCE**

Input Terminal	Sensitivity		Impedance
	Rated Output	New IHF Std. (0.5V Output)	
DISC (Head Amp Off/MM)	2.0 mV	0.5 mV	47 kΩ
DISC (Head Amp +26 dB)	0.1 mV	0.025 mV	10/30/100 Ω
DISC (Head Amp +32 dB)	0.05 mV	0.0125 mV	10/30/100 Ω
TUNER/LINE/TAPE PLAY	126 mV	31.5 mV	20 kΩ

● **OUTPUT LEVEL AND IMPEDANCE**

OUTPUT (UNBALANCED)
 2.0 V, 1.0 Ω (Connector: Phono Jack)
 OUTPUT (BALANCED)
 2.0 V, 600 Ω (Connector: XLR type)
 TAPE REC: 126 mV, 200 Ω (Input: DISC)

● **A-WEIGHTED SIGNAL-TO-NOISE RATIO**

Input Terminal	Rated Output	New IHF Standard
DISC (Head Amp Off/MM)	85 dB	82 dB
DISC (Head Amp +26 dB)	72 dB	76 dB
DISC (Head Amp +32 dB)	66 dB	76 dB
TUNER/LINE/TAPE PLAY	110 dB	88 dB

● **MAXIMUM OUTPUT LEVEL (at 0.005% distortion, 20 Hz to 20,000 Hz)**

OUTPUT (UNBALANCED) 10.0 V
 OUTPUT (BALANCED) 10.0 V
 TAPE REC. 19.0 V
 (Input: DISC)

● **MAXIMUM INPUT FOR DISC INPUT (at 0.005% distortion, 1 kHz)**

HEAD AMP OFF 300 mV
 HEAD AMP +26 dB 15 mV
 HEAD AMP +32 dB 7.5 mV

● **MINIMUM LOAD IMPEDANCE**

OUTPUT (UNBALANCED) 1 kΩ
 TAPE REC. 10 kΩ

● **VOLTAGE AMPLIFICATION IN DECIBELS**

TUNER/LINE/TAPE PLAY—Input to OUTPUT: 24 dB
 TUNER/LINE/TAPE PLAY—Input to TAPE REC Output: 0 dB
 DISC (Head Amp Off/MM)—Input to OUTPUT: 60 dB
 DISC (Head Amp Off/MM)—Input to TAPE REC Output: 36 dB
 HEAD AMP gain: Selectable for +26 dB and +32 dB

● **LOUDNESS COMPENSATOR (volume attenuation at -30 dB)**

- +3 dB at 100 Hz
- +8 dB at 100 Hz +6 dB at 20 kHz

● **SUBSONIC FILTER** 10 Hz cutoff, 18 dB/oct

● **ATTENUATOR** -20 dB, -30 dB and infinity

● **SEMICONDUCTOR COMPLEMENT**

225 Tr's, 16 FETs, 33 ICs and 167 Di's

● **POWER REQUIREMENT**

Voltage Selector for 100, 117, 220 and 240 V, 50/60 Hz operation
 Power Consumption: 75 W

● **DIMENSIONS**

468 mm (18-7/16 inches) width,
 171 mm (6-12/16 inches) max. height,
 396 mm (15-9/16 inches) depth

● **WEIGHT**

18.1 kg (39.9 lbs) net,
 23.1 kg (50.9 lbs) in shipping carton

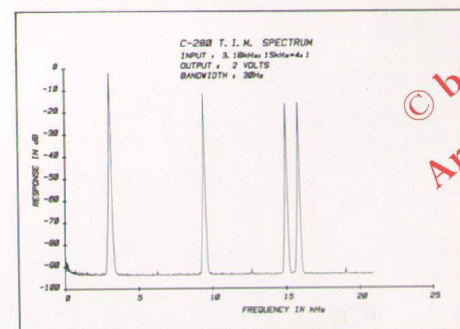
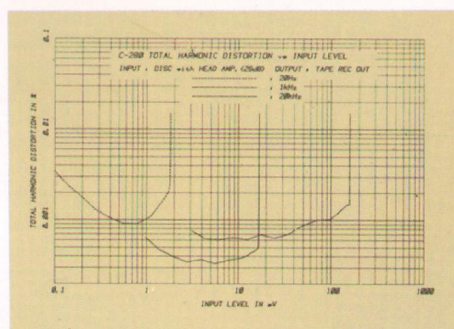
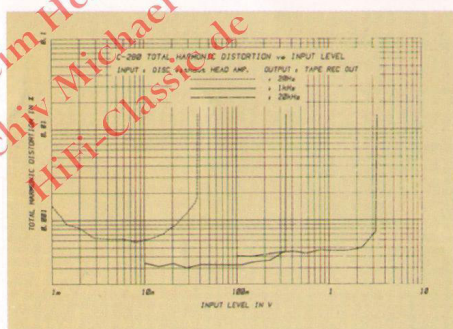
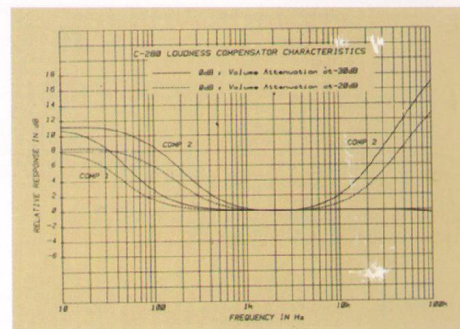
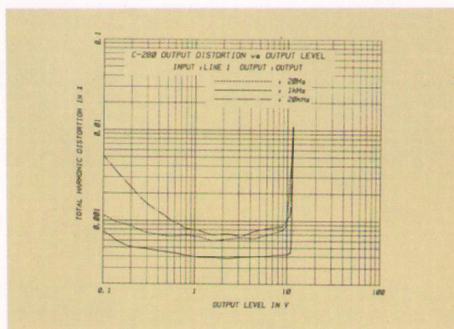
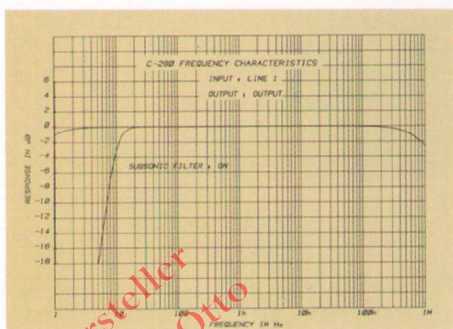

The above data shows the spectrum characteristics of transient intermodulation distortion for the C-280 when two mixed input signals, a 3.18 kHz square wave and a 15 kHz sine wave, are used. Since harmonics of square waves appear almost infinitely at odd number multiples, for example in this case at 9.54 kHz (3rd harmonic), 15.9 kHz (5th harmonic), they can create, together with the 15 kHz input sine wave, intermodulated spectrums at frequencies where input signals are absent. For example, if the third harmonic of the 3.18 kHz square wave (9.54 kHz) and the 15 kHz input signal intermodulate, a spectrum can appear at the difference of their frequencies or 5.46 kHz (15-9.54=5.46 kHz). However, the above data shows no spectrum above -93 dB at that frequency which confirms that TIM distortion is less than 0.0022%. Spectrums appear at frequencies of 6.36 kHz, 12.72 kHz and 19.08 kHz are even number harmonics included in the original square wave signal.

