

Accuphase

C-230

- STEREO CONTROL CENTER
- MOS FETs OUTPUT STAGE
- BUILT-IN HEAD AMPLIFIER



The Accuphase C-230 is a high gain control center which symbolizes the combined aggregation of Accuphase audio technology. It has a built-in head amplifier for direct connection of moving-coil cartridges and a full-fledged headphone amplifier for fidelity monitoring functions. The versatility of its tone control functions is one of its special features in addition to all the standard functions that are available in the highest grade Accuphase C-240 control center.

It employs the basic "Accuphase Original" complementary-symmetry push-pull driven circuitry in every stage, which, moreover, features Class-A operated DC amplification throughout. Furthermore, it utilizes a newly innovated DC Servo Control system in its high level amplifier, which has made unnecessary all input and output capacitors, as well as large capacitances in the Negative Feedback Loop (NFB) that alters sound characteristics.

The C-230's equalizer and head amplifier outputs employ MOS FETs (Metal-Oxide Semiconductor FETs) for the first time in the world. This was decided for the very good reason that MOS FETs in Class-A operation were judged to deliver the highest quality reproduction after extensive listening tests conducted over a long period by Accuphase engineers. We are confident that we have perfected a control center of the highest order in the C-230 with which the inner world of musical reproduction can be enjoyed to the full extent.

1 COMPLEMENTARY-SYMMETRY, CLASS-A PUSH-PULL DRIVEN ICL (Input Capacitor-Less) DC AMPLIFIER CIRCUITS THROUGHOUT

The keypoint in creating a superior amplifier is to design one with the best inherent characteristics, together with minimum sound coloration. The C-230 got off to a good start here because it employs one of the most extravagant circuits — Complementary-symmetry push-pull drive — in every stage from the head amplifier input to the final stage output, and also even in its headphone amplifier circuit. The superior of this circuit's inherent characteristics is outstanding, especially in linearity, as well as in its very low distortion and very high stability characteristics. Moreover, the C-230's highly perfected DC amplifier system has practically eliminated sound coloration by making unnecessary DC blocking capacitors from the NFB loop as well as all coupling capacitors in a true Input Capacitor-Less (ICL) design. It also permits direct connection of phono cartridges which assure higher quality sound reproduction.

2 MOS FETs USED IN OUTPUT STAGE

One of the advantages of MOS FETs, which are recognized as the most promising devices for power amplification applications, is that there is no notching distortion since they are voltage controlled. Overall characteristics in the C-230 have been greatly improved by employing MOS FETs in the output stages of its equalizer and high level amplifiers. It is the first time anywhere that this device has been utilized in a control center. Accuphase elected MOS FETs for the job because of their tested effectiveness in further upgrading sound quality.

3 EXCLUSIVE VOLTAGE REGULATED POWER SUPPLY FOR ALL UNIT AMPS

Recent active devices are capable of extending the overall bandwidth by several megahertz even under ordinary operation. However, the effectiveness of such wideband amplifiers is halved in the high frequency range because of circuit impedance, regardless of low impedance electrodes that might be used. The ideal solution would be to position a voltage regulated power supply directly at the base of each amplifying devices.

All the unit amplifiers in the C-230 are equipped with their own exclusive voltage regulated power supplies. They are located on the respective unit amplifier printed circuit boards to keep circuit impedance to a minimum. The outstanding stability of the C-230's various characteristics is due to this almost ideal, extravagant Accuphase design approach.

4 DC SERVO CONTROL, LOW OUTPUT IMPEDANCE, HIGH LEVEL AMPLIFIER

It is the normal practice in high level amplifiers to combine a tone

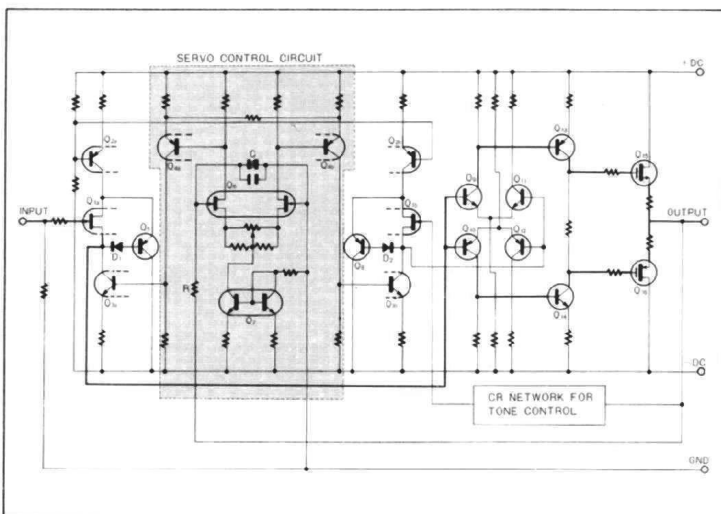

Fig. 1 DIAGRAM OF SERVO CONTROLLED HIGH-LEVEL AMPLIFIER

control function and accomplish this by varying the capacitance and resistance of the negative feedback (NF) loop. In such cases, even a small DC current in the amplifier output can cause a large pulse type "shock noise" during switching. A DC blocking capacitor is usually used to prevent this, but such an amplifier no longer functions as a DC amplifier and the blocking capacitor will cause sound coloration.

A DC Servo Control System (PAT. PEND.) is utilized in the C-230, as in the case of the C-240, to make such a blocking capacitor unnecessary. This innovation permits the C-230 to operate as a pure DC amplifier even when the tone control is used, since it can hold DC drift to practically zero.

Figure 1 shows the high level amplifier with the DC Servo Control Circuit in the shaded area, enclosed by the broken lines. If DC drift should appear at the amplifier output, the Servo Control system operates to control Q_3 , the constant current load of the input buffer device Q_1 . In effect, any DC drift detected at the output is amplified and utilized to control the bias of the buffer Q_1 and keep the output always at "0" potential. A big advantage of this Servo system is that it does not affect sound reproduction since it merely controls the constant current load of the input buffer device, and does not directly control the signal path stage.

The capacitive feedback of the buffer device Q_1 can cause high frequency distortion if left unattended. A compensating capacitor be used to prevent this distortion, but it has the disadvantage of altering the sound. The C-230 uses a feedback cancelling circuit built around Q_5 , Q_6 , D_1 and D_2 which prevents capacitive feedback and preserves the sound character at the same time.

5 SOUND COLORATION ELIMINATED IN HIGH S/N EQUALIZER AMP

The equalizer amplifier section which faithfully adheres to the RIAA equalization curve and has a gain of more than 30dB requires the highest design technology. Figure 2 shows the circuit which is probably one of the most thoroughly designed equalizer amplifiers ever perfected. Built around 15 active devices, using Class-A operated MOS FETs at its output to achieve large current drive and low output impedance, it is designed simultaneously to obtain highest S/N ratio with low impedance of the NF loop. A high S/N ratio that is close to the theoretical limit was actually achieved by the addition of a high Gm input buffer.

The equalizer amplifier also utilizes a feedback canceller circuit built around Q_2 , Q_3 , D_1 and D_2 to prevent sound quality deterioration from the capacitive feedback of the input device. The design of this input circuit, to which cartridges with reactance characteristics must be directly connected, is all important. Capacitive compensation for this purpose should not be employed because of mutual CR effects that may alter frequency response characteristics.

Fig. 3 shows the IM distortion data measured with two close proximity frequencies under New IHF Measuring Method which was revised in 1978 and is called as "NEW IHF-IM". This new method brings out the similar distortion to the dynamic one which could not be measured by the measuring method of distortion stated afterward and

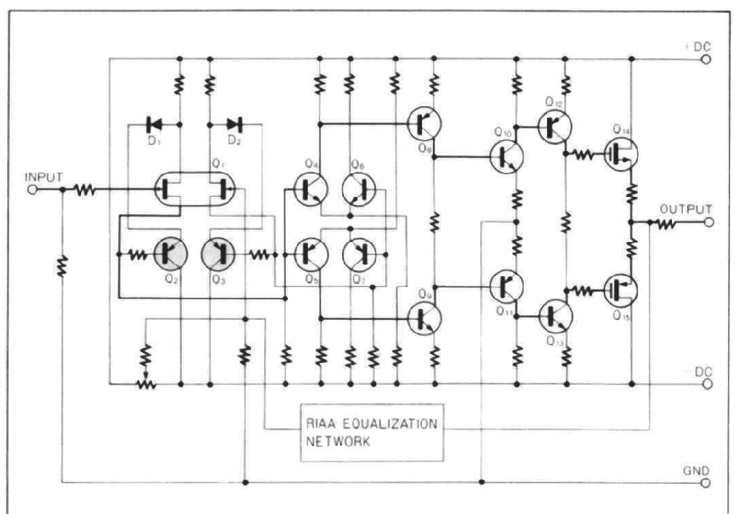

Fig. 2 DIAGRAM OF EQUALIZER AMPLIFIER

Accuphase C-230

STEREO CONTROL CENTER

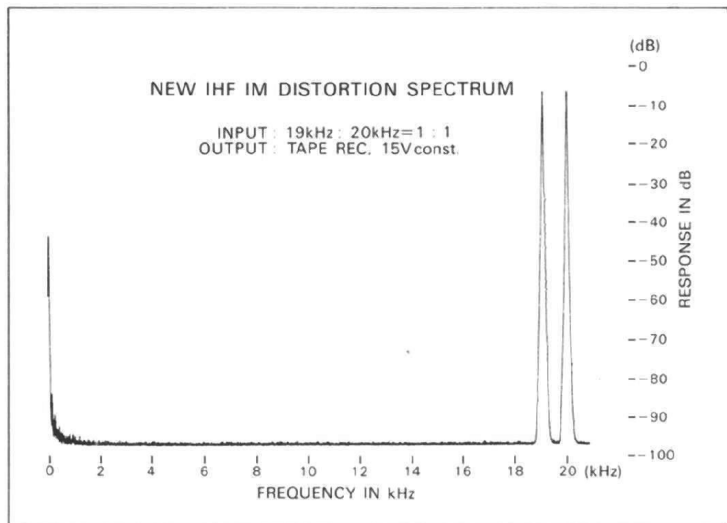

Fig. 3 NEW IHF-IM DISTORTION SPECTRUM

the usual method done by two far away frequencies.

When plural signals close each other in frequency cause non-linear distortion, as well as the harmonic distortion of each original signals, a third signal of difference in frequency between each signals appears and deteriorates the reproduction sound. This is the New IHF-IM Distortion and is occasionally called as Beat Distortion.

Refer to Fig. 3. It shows a distortion spectrum of the C-230's Equalizer Amplifier which was measured under the condition that at output of 15V, input signal in frequencies of 19kHz and 20kHz at the rate of 50 to 50 was fed. If the IHF-IM Distortion had been caused in the C-230, spectrums of harmonics should have appeared at the frequencies of 1kHz, 2kHz, 3kHz and so on. The Fig. 3 attests the truth that none of IM Distortion have been detected and any distortion are out of measuring limit of 0.0027%.

Two Disc Inputs are provided and one of them is equipped with an input impedance matching selector which provides selection of 100 ohms, 47k ohms, 82k ohms and 150k ohms input impedances.

6 HIGH S/N RATIO HEAD AMPLIFIER

To enjoy the special musical reproduction mood of moving-coil cartridges which cannot be realized with MM (Moving-Magnet) or IM (Induced-Magnet) type cartridges, a high grade head amplifier that's capable of reproducing the difference is required. The complementary-symmetry push-pull head amplifier of the C-230 can be connected directly to Moving-Coil (MC) cartridges, as mentioned above, to realize a clearer, richer, more detailed sound reproduction character.

Also the very latest, low-noise transistors were selected because of the very low level signals handled, and a high signal to noise ratio that is close to the theoretical limit was successfully achieved. Choice of the two DISC inputs is offered by switch selection.

7 CLASS-A SYMMETRICAL, PUSH-PULL DIRECT COUPLED HEADPHONE AMPLIFIER

An added-value, hidden feature of the C-230 is the built-in, full-fledged headphone amplifier which it contains. It is a completely independent, Class-A amplifier with direct coupled, complementary-symmetry push-pull circuitry. It is ideal for monitoring program sources to check the fidelity of reproduction quality.

8 TURNOVER SELECTOR SWITCH

A turnover selector switch is provided to expand the tone control function. This provides selection of 200 Hz and 500 Hz turnover frequencies for BASS, and 2kHz and 7kHz for TREBLE. The turnover selections of 200Hz and 7kHz are especially effective for smooth control over the widest range from the deepest bass to the highest treble tones. Furthermore, a 10-step rotary switch permits accurate 10-step tonal variations, as well as on/off switching of the tone control circuit.

9 THREE-STEP LOUDNESS COMPENSATION

Three-Step Loudness compensator switch provides a choice of three sound energy balancing curves to make up for the deficiency of the human ear to detect certain audio frequencies during low-level reproduction. This switch also helps to balance out listening room characteristics. COMP 1 provides compensation of +6 dB at 50 Hz; COMP 2: +9 dB at 50 Hz, and COMP 3: +10 dB at 50 Hz and also +6 dB at 20 kHz. (above values when volume control at -30dB).

10 SUBSONIC FILTER

The provision of filters was based on practicality, and only a 17 Hz 12dB/oct subsonic filter is made available. It is an active filter that was designed to cut off frequencies below 17 Hz that sometimes might cause intermodulation distortion in the audible frequency range.

11 COMPLETE TAPE RECORDER FUNCTIONS

Two tape recorders can be connected. An independent copy switch is provided which permits tape copying from one machine to the other, and simultaneous enjoyment of a different program source. The output for the tape recording can be cut off by an independent switch as occasion demands. This switch also effectively prevents distortion that may otherwise be caused when the AC power of the tape recorder is at off, and the input circuit of the tape machine poses a load to the control center.

12 OTHER FUNCTIONS

This amplifier is equipped with many other useful functions such as a -20dB Attenuator Switch which is convenient to start off records, a switch to cut off the recording output connection of tape recorders to prevent distortion, and a Switch to select mode of REVERSE, STEREO and MONO.

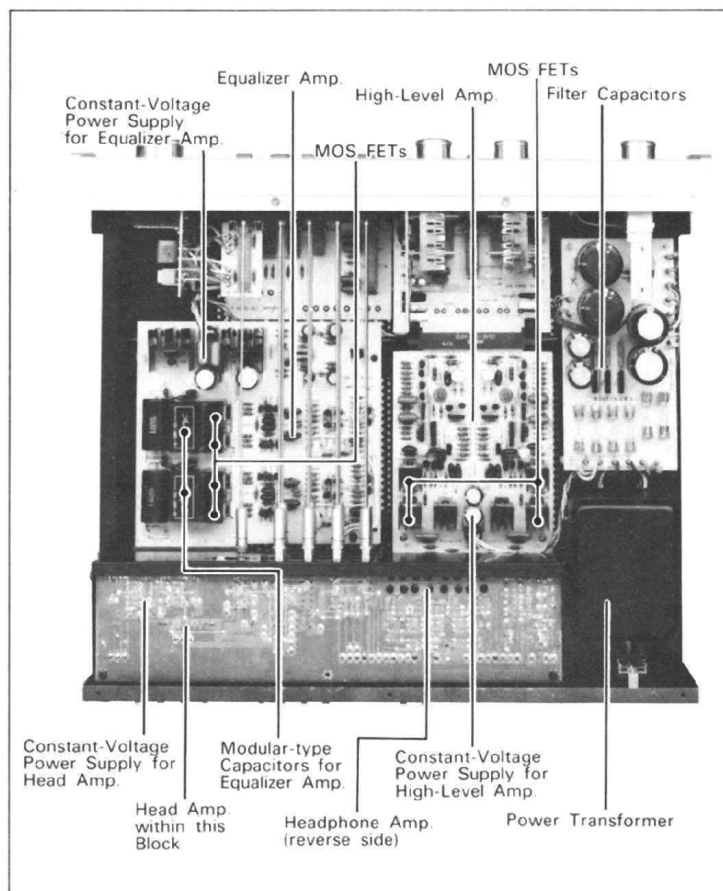

Accuphase C-230

STEREO CONTROL CENTER

GUARANTY SPECIFICATIONS

PERFORMANCE GUARANTY:

All Accuphase product specifications are guaranteed as stated.

FREQUENCY RESPONSE: (New IHF)

High level input: +0, -0.2dB, 20Hz to 20,000Hz
 Low level input: ±0.2dB, 20Hz to 20,000Hz

DISTORTION: (New IHF THD+N)

Better than 0.005% at rated output level throughout all stages, 20Hz to 20,000Hz

INPUT SENSITIVITY AND IMPEDANCE:

INPUT	SENSITIVITY RATED OUTPUT	0.5V OUTPUT (New IHF)	IMPEDANCE OHMS
Disc (HEAD AMP: ON)	0.125mV	0.05mV	100
Disc (HEAD AMP: OFF)	2.5mV	0.96mV	100, 47k, 82k, 150k
Aux., Tuner Tape Play	160mV	62mV	47k

MAXIMUM INPUT FOR DISC INPUT:

Disc 1, 2 (without HEAD AMP.): 300mV RMS for 1,000Hz, with 0.005% Distortion (THD+N)
 Disc 1, 2 (with HEAD AMP.): 15mV RMS for 1,000Hz, with 0.005% Distortion (THD+N)

OUTPUT LEVEL AND IMPEDANCE:

Outputs 1.3V*; 20 ohms
 Tape Rec. 160mV; 200 ohms
 (*at rated input, volume control maximum)

HEADPHONE:

Output Impedance 0.3 ohms
 Power Output 0.25 watts at 8 ohms load, 1kHz, with 0.01% Distortion (THD+N)

MAXIMUM OUTPUT LEVEL:

8 volts with 0.005% distortion (THD+N), 20Hz to 20,000Hz

VOLTAGE AMPLIFICATION IN DECIBELS:

Tuner, Aux., Tape Play input: to Tape Rec.; 0dB
 to Outputs; 18dB
 to Headphones; 18dB
 Disc input (without HEAD AMP.): to Tape Rec.; 36dB
 to Outputs; 54dB
 to Headphones; 54dB
 (26dB additionally with HEAD AMP.)

A-WEIGHTED SIGNAL TO NOISE:

At rated output, inputs shorted, with IHF-A weighted
 Tuner, Aux., Tape Play input: 112dB
 Disc input (Head Amp: OFF): 87dB
 Disc input (Head Amp: ON): 74dB
 New IHF standard
 Tuner, Aux., Tape Play input: 92dB
 Disc input (Head Amp: OFF): 85dB
 Disc input (Head Amp: ON): 76dB

MINIMUM IMPEDANCE OF OUTPUT LOAD:

Outputs 1k ohms
 Tape Rec. 10k ohms

TONE CONTROLS:

11-positions Rotary Switch for both channels with turnover frequency switches
 BASS: Turnover frequency 500Hz; ±10dB (2dB step) at 100Hz
 Turnover frequency 200Hz; ±10dB (2dB step) at 50Hz
 TREBLE: Turnover frequency 2,000Hz; ±10dB (2dB step) at 10,000Hz
 Turnover frequency 7,000Hz; ±10dB (2dB step) at 50,000Hz

LOUDNESS COMPENSATOR: (Volume attenuation at -30dB)

COMP. 1; +6dB at 50Hz
 COMP. 2; +9dB at 50Hz
 COMP. 3; +10dB at 50Hz, +6dB at 20,000Hz

SUBSONIC FILTER:

17Hz cutoff 12dB/oct.

ATTENUATOR:

-20dB

POWER REQUIREMENT:

Voltage selector for 100V, 117V, 220V, 240V, 50/60Hz operation, Consumption: 35W

SEMICONDUCTOR COMPLEMENT:

85 TRs, 16 FETs, 5 ICs and 22 DI's

DIMENSIONS:

445mm (17-1/2 inches) width, 128mm (5-1/16 inches) max. height, 370mm (14-9/16 inches) depth

WEIGHT:

10.0kg (22.0 lbs) net, 14.4kg (31.7 lbs) in shipping carton

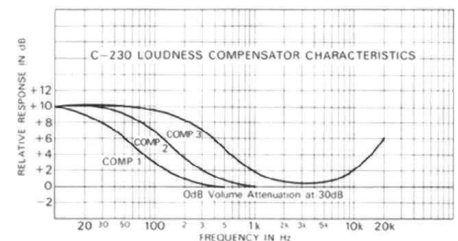
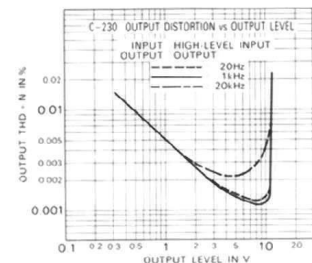
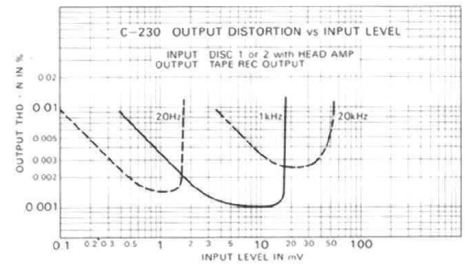
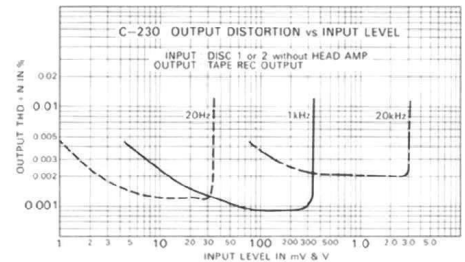
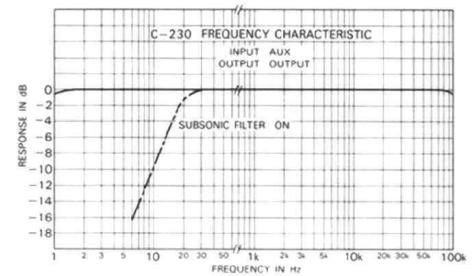

© beim Hersteller
 Archiv Michael Otto
 HiFi-Classic.de

