

Accuphase

STEREO CONTROL CENTER

C-200X

- Direct-coupled Amp. with New DC Servo Controlled Circuit
- Built-in Head Amplifier
- Heavy-duty Multiple Power Supplies



The Accuphase C-200X is a preamplifier that has wide functional capabilities befitting its description as a Stereo Control Center, with its convenient Sub Panel controls and connectors located beneath the front panel, an Accuphase tradition that was first introduced in our C-200. In addition, it has a built-in high quality head amplifier for exclusive use with MC (Moving Coil) cartridges.

Outstanding performance ratings and highest quality are assured by the C-200X which is based on the Accuphase original complementary-symmetry, push-pull circuitry enhanced with a further developed Cascode Bootstrap Differential Push-Pull input stage and new DC Servo Control circuitry.

Separate unit amplifiers that are plugged in and combined on a central epoxy glass "Motherboard" form the basic scheme of wiring construction. This system has contributed greatly to its superior and uniform performance characteristics.

The C-200X features a unique Multiple Power Supply system in which each unit amplifier for each channel is provided with its own regulated power supply circuit that completely eliminated interamplifier interference.

The C-200X is a high grade Stereo Control Center which was perfected to meet every conceivable requirement befitting its description, including its use as a standard for comparing preamplifier performance.

1 CASCODE BOOTSTRAP COMPLEMENTARY-SYMMETRY, PUSH-PULL CIRCUITRY

Accuphase amplifiers have traditionally employed the complementary-symmetry, push-pull circuitry because of its superior basic characteristics (even before NFB application) and high stability. This original Accuphase circuitry also produces a clearer, superior and more dynamic sound.

In addition to this basic circuitry, the C-200X also employs a further developed Cascode Bootstrap Push-Pull Differential Input amplifier.

The diagram below shows the complete circuitry with Q1 through Q12 forming the input stage. Cascode construction is employed for the input stage which consists of Q1Q3 and Q2Q4 respectively. The source electrode of Q1 connects to the base of Q4, after passing through R7, and the source electrode of Q2 connects to the base of Q3, after passing through R6 to form a bootstrap configuration. Likewise, Q11Q9 and Q12Q10 on the inverting input are connected in similar fashion.

This cascode bootstrap system achieves high gain together with improved high frequency characteristics. At the same time, it helps to reduce distortion of high impedance input loads, so it is useful for handling high impedance MM (Moving Magnet) cartridges, and beneficial in high level amplifier stages after the volume control. Accordingly, the C-200X employs this circuitry in its equalizer and high level amplifier sections.

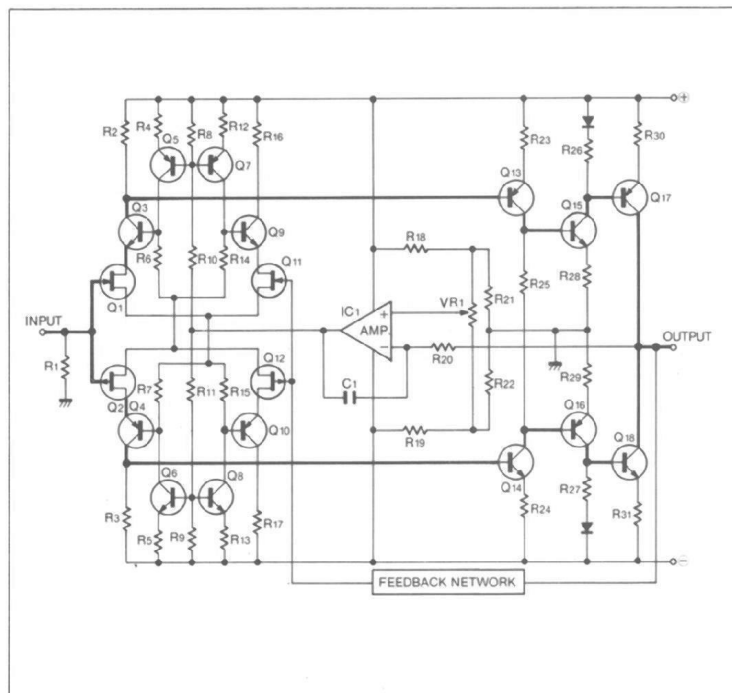

Cascode Bootstrap construction of the Equalizer and High-level Amplifiers

2 PURE DC AMPLIFIER SYSTEM REALIZED WITH NEW SERVO CONTROL SCHEME

Since FETs are used at the inputs as shown in the circuit diagram, direct coupling is possible for all amplifier stages as long as DC current flow from temperature and voltage changes are prevented in the output circuits.

The C-200X employs new type DC Servo Control Systems in its equalizer amplifiers and tone control amplifiers which have made possible a pure DC (direct coupled) amplifier system all the way from the Moving Magnet DISC input to the final output. This has further improved its higher quality sound reproduction performance. IC1 in the circuit diagram indicates the DC Servo amplifier. Its time constant is determined by C1 and R20. Instead of directly controlling the audio signal path of the differential amplifier, the output of IC1 is used in a new scheme to control the base currents of Q5Q7Q6Q8 which function as the source for constant regulated current. This system minimizes any effect that noise created in the Servo Control circuit may have on the audio signal path, and also more effectively prevents DC (direct current) drift. Therefore, it assures superior results when employed in low level, high gain equalizer amplifiers as in the C-200X. A pure DC amplifier system from DISC input to the final output has been realized together with a significant improvement in reproduction, thanks to this new DC Servo Control circuit.

3 CLASS-A COMPLEMENTARY-SYMMETRY, PUSH-PULL HEAD AMPLIFIER

Close attention was paid in designing the C-200X to give full play to the reproduction capabilities of MC (Moving Coil) cartridges. For that purpose this control center is provided with a differential amplifier system at the input, and a complementary-symmetry, push-pull output stage that employs RETs (Ring Emitter Transistors). The former has eliminated the need for a coupling capacitor at the input, and its harmful effects on sound quality. It has instead made possible direct coupling of MC cartridges to the head amplifier which accounts for a reproduction sound that is characterized by superior expressive power in revealing musical details with outstanding clarity.

Only one tonearm is required for both MC and MM cartridges since the head amplifier is switch controlled for the three inputs. Therefore, MC and MM cartridges can be interchanged by plug-in process into a common tonearm.

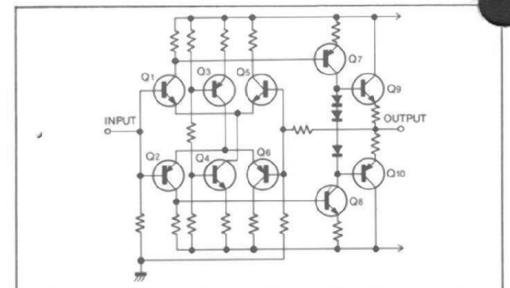

Circuit Diagram of the Head Amplifier

4 HEAVY-DUTY MULTIPLE POWER SUPPLIES

An ideal power supply is one which has low output impedance over a wide range, and further which absolutely does not affect the characteristics of the amplifier circuitry that it supplies. This means that the ideal setup between the power supply and unit amplifiers would be direct connections without lead wires.

With the aim of coming as close to this ideal as possible and eliminating cross interference between amplifier units, the C-200X employs an extravagant Multiple Power Supply system. It is built around six independent regulated power supply circuits comprised of RETs and ICs, one each for each head amplifier, equalizer amplifier and high level amplifier of each left and right channel.

These independent power supply circuits which maintain low impedance over a wide range are positioned strategically very closely to the respective unit amplifiers that they supply. This has completely eliminated interference between unit amplifiers. It also accounts for richer bass reproduction and improved sound focus qualities.

Accuphase C-200X

STEREO CONTROL CENTER

5 MOTHERBOARD SYSTEM ACCOUNTS FOR HIGH STABILITY OF PERFORMANCE

A motherboard system which contains unit amplifiers, power supply sections and conductive printed channels to tie in the separate sections is used in the C-200X. It is an epoxy glass motherboard on which plug-in sockets for the unit amplifiers, power supplies and rectifiers, filter capacitors and front panel push switches are mounted.

Various sections are connected together by conductive printed channels which have replaced conventional wiring and greatly improved stability and uniformity of performance, not always ensured by past inconsistent wiring methods.

However, motherboard type construction also poses the danger of obtaining uniformity of poor characteristics if the original engineering design happens to be inadequate.

The C-200X therefore has been designed with utmost care, and affected only after repeated, exhaustive tests to achieve maximum performance.

6 CLASS-A SYMMETRICAL, PUSH-PULL DIRECT COUPLED HEADPHONE AMP

One of the hidden features is the provision of an exclusive headphone amplifier. It is a Class-A, complementary-symmetry, DC amplifier which reproduces sound most faithfully. It is also valuable for monitoring program sources in which checking sound quality takes first priority.

7 WIDE TONE CONTROL CHOICES

Separate tone control circuits are provided for the left and right channels. Tone is varied with a 10-step rotary switch in 2dB steps. The circuitry also offers switch selection of turnover frequencies, which further widens tonal variation choices in the lower and high frequency ranges with 200Hz and 500Hz bass turnover frequency points, and 2kHz and 7kHz treble turnover frequencies. Also available is an ON/OFF Switch with which the tone control circuitry can be cut off or activated as desired.

8 TWO-STEP LOUDNESS COMPENSATOR

A two-step Loudness Compensator Switch provides a choice of two sound energy balancing curves to make up for the deficiency of the human ear to detect certain audio frequencies during low level reproduction. Choice of the two compensating curves are offered, selection of which is governed by the sound reproduction level and listening room acoustics. COMP 1 provides a +3dB boost at 100Hz. COMP 2 provides a +10dB boost at 100Hz and a +5dB boost at 20kHz. (with volume set at -30dB)

9 SUBSONIC AND HIGH FILTERS

Since present day audio components and program sources have undergone much improvement, irritating noise is practically non-existent. Rather the problem today lies in intermodulation distortion that may be caused by subsonic frequencies. This preamplifier has a built-in Subsonic Filter (12dB/oct. at 17Hz) designed to eliminate such subsonic sources of intermodulation distortion.

It also has a High Filter (12dB/oct. at 8kHz) which has characteristics that effectively eliminates tape hiss, while keeping high frequency response characteristic losses to a minimum.

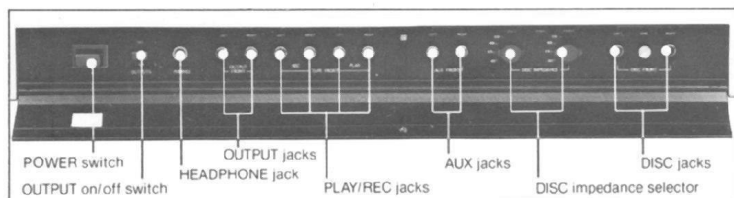

Functions in the Sub Panel

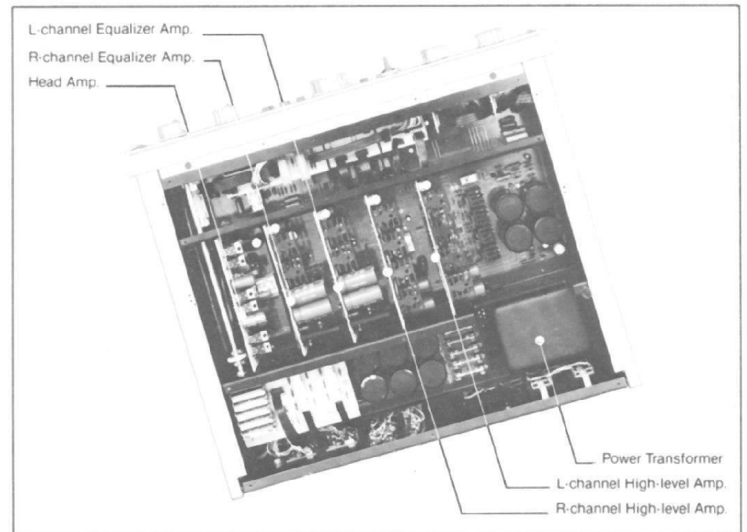

Internal View

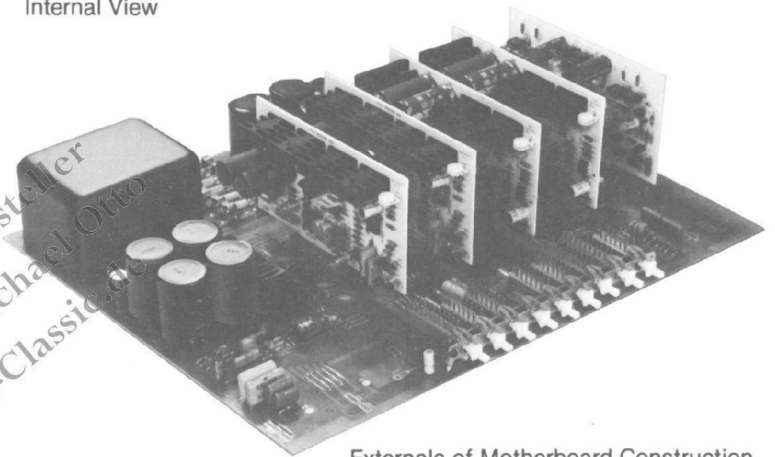

Externals of Motherboard Construction

10 COMPLETE TAPE RECORDER FUNCTIONS

A total of three tape recorders can be connected to this preamplifier (one to the front Sub Panel). Any two of these machines can be used for tape copying from one machine to another. This can be done while simultaneously listening to a completely different program source since the Copying Switch is independent.

11 PLENTY OF INPUT/OUTPUT CONNECTORS

Plenty of INPUT/OUTPUT connectors are available for convenience in handling a large number of program sources, and conducting various tests of sound equipment. A total of nine inputs include three pairs of DISC, one pair for TUNER, two pairs of AUX and three pairs of TAPE PLAY connectors.

This preamplifier also has a total of seven outputs that include three pairs each of OUTPUT and TAPE REC connectors and one headphone jack.

One pair each of DISC, AUX, TAPE PLAY, TAPE REC, and OUTPUT connectors and a Headphone jack are located on the frontside Sub Panel for convenience in making tests, etc., and also to eliminate complexity. The DISC input in the Sub Panel is especially useful for testing turntables and phono cartridges.

12 OTHER FUNCTIONS

This Stereo Control Center provides other convenient functional controls such as a -20dB Attenuator Switch to start off records and tapes, a 5-point rotary switch for selecting the mode of operation, a DISC Input Impedance Selector Switch and Output On/Off Switch.

Accuphase C-200X

STEREO CONTROL CENTER

GUARANTY SPECIFICATIONS

PERFORMANCE GUARANTY:

All Accuphase product specifications are guaranteed as stated.

FREQUENCY RESPONSE: (New IHF) High-level Input: +0, -0.2dB 20Hz to 20,000Hz
 Low-level Input: +0.2, -0.2dB 20Hz to 20,000Hz

DISTORTION: Lower than 0.005% at rated output level, 20Hz to 20,000Hz (New IHF)

INPUT SENSITIVITY AND IMPEDANCE:

INPUT	SENSITIVITY		IMPEDANCE
	AT RATED OUTPUT	AT 0.5V OUTPUT (NEW IHF)	
DISC (HEAD AMP: OFF):	2.0mV	0.5mV	DISC 1/DISC FRONT: 100, 47k, 82k, 150k ohms, DISC 2: 47k ohms
DISC (HEAD AMP: ON):	0.1mV	0.025mV	
TUNER/AUX/TAPE PLAY:	126mV	31.5mV	100 ohms 47k ohms

OUTPUT LEVEL AND IMPEDANCE:

OUTPUT: 2.0V*, 2 ohms (*at rated input level, volume control maximum)
 TAPE REC: 126mV, 200 ohms

HEADPHONES: OUTPUT IMPEDANCE: 0.3 ohm
 OUTPUT POWER: 0.25W (8 ohms load) at 1kHz, 0.01% distortion
 (at rated input level, volume control maximum)

MAXIMUM OUTPUT LEVEL: 10 Volts at 0.005% distortion, 20Hz to 20,000Hz

MAXIMUM INPUT FOR DISC INPUT:

HEAD AMP OFF: 400mV RMS for 1kHz at 0.005% distortion
 HEAD AMP ON: 20mV RMS for 1kHz at 0.005% distortion

OUTPUT LOAD IMPEDANCE: OUTPUT: 1k ohm minimum
 TAPE REC: 10k ohms minimum

VOLTAGE AMPLIFICATION IN DECIBELS:

TUNER, AUX, TAPE PLAY input: to TAPE REC: 0dB
 to OUTPUT: 24dB
 to HEADPHONES, 20dB

DISC input: to TAPE REC: 36dB/62dB*
 to OUTPUT: 60dB/86dB*
 (* HEAD AMP switch set to ON)

A-WEIGHTED SIGNAL-TO-NOISE RATIO: (at rated input)

High-level Input: 110dB below rated output, IHF-A weighted, 88dB (New IHF)
 Disc Input (without HEAD AMP): 85dB below rated output, IHF-A weighted, 82dB (New IHF)
 Disc Input (with HEAD AMP): 72dB below rated output, IHF-A weighted, 74dB (New IHF)

TONE CONTROLS:

10-step Rotary Switch for both channels with turnover frequency switches and DEFEAT switch.
 Tone is varied in 2dB steps.
BASS: Turnover Frequency 500Hz: ±10dB at 100Hz
 200Hz: ±10dB at 35Hz
TREBLE: Turnover Frequency 2,000Hz: ±10dB at 10kHz
 7,000Hz: ±10dB at 35kHz

LOUDNESS COMPENSATOR: (Volume Attenuation at -30dB)

COMP 1: +3dB (100Hz)
 COMP 2: +10dB (100Hz), +5dB (20kHz)

ATTENUATOR: -20dB

SUBSONIC FILTER: 17Hz cutoff 12dB/oct.

HIGH FILTER: 8kHz cutoff 12dB/oct.

SEMICONDUCTOR COMPLEMENT: 102 Tr's, 29 FETs, 50 DI's and 11 IC's

POWER REQUIREMENT: Voltage Selector for 100, 117, 220, 240V 50/60Hz operation
 Consumption: 80 watts

DIMENSIONS: 445mm (17-1/2 inches) width
 160mm (6-5/16 inches) max. height
 373mm (14-11/16 inches) depth

WEIGHT: 13.4kg (29.5 lbs.) net, 17.4kg (38.3 lbs.) in shipping carton

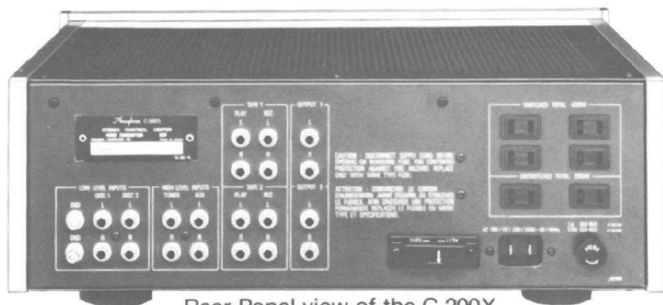

Rear Panel view of the C-200X

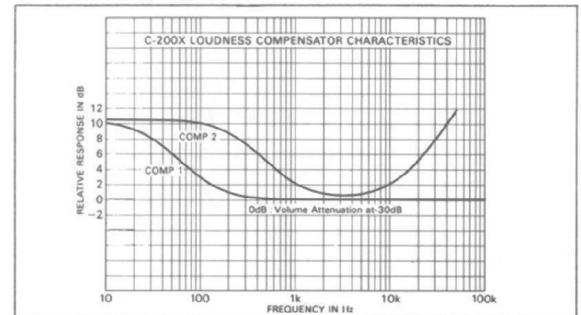
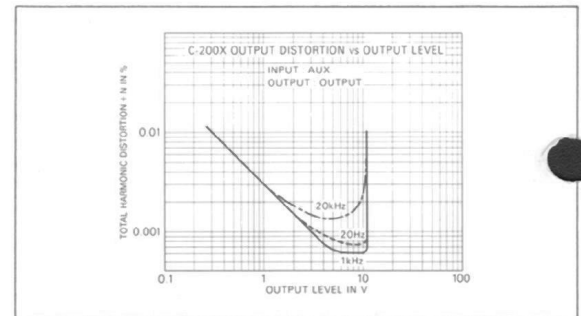
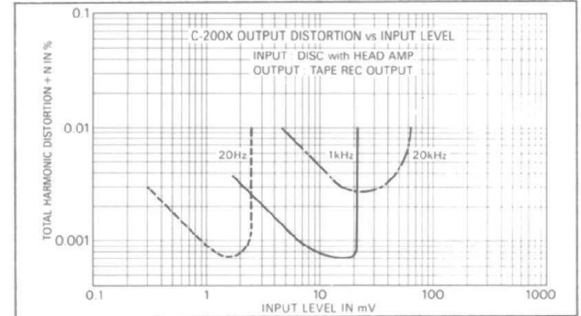
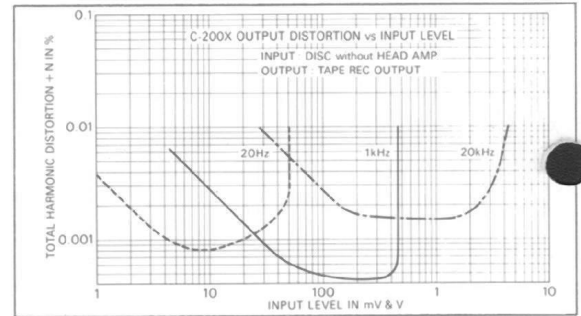
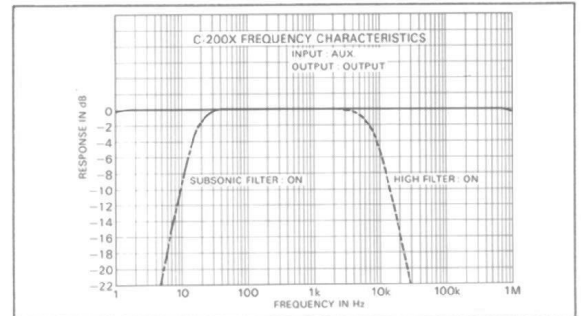

© beim Hersteller
 Archiv Michael Otto
 HiFi-Classic.de

