

Accuphase

STEREO CONTROL CENTER

C-200L

- Multifunction head amps incorporated
- All stage push-pull circuitry
- DC servo controlled throughout
- All unit amps provided with exclusive regulated power supply
- 3P XLR connectors (balanced output) provided



© beim Hersteller
Archiv Michael Otto
HiFi-Classic.de

POWER

STEREO CONTROL CENTER C-200L

Accuphase

Accuphase C-200L

STEREO CONTROL CENTER

The advent of digital recordings (PCM) and compact discs (CD) reveals a growing trend toward digitization of audio equipment. In parallel with this trend, the reproduction capabilities of conventional audio devices such as analog discs and cartridges have shown a significant amelioration due to the improvement of record players, amplifiers, and other equipment. Moreover, the profusion of video devices that can be connected to an audio system has ushered in an era where multiple program sources can be used for an audio system.

The C-200L is an advanced Control Center employing the philosophy of "Push-Pull Circuitry in every stage" and in addition possesses the circuitry that was the core of the higher-grade C-280 Series. The basic amplifier circuit is of a "Class-A Cascode Push-Pull" configuration which provides excellent high-frequency characteristics, linearity, and signal-to-noise ratio. This basic amplifier circuit employs a great

number of cascode push-pull circuits. Many of these basic amplifier circuits are employed here and there in a unit amplifier. The upper-limit characteristics of each unit amplifier is thus attained.

A total of six unit amplifiers, consisting of one head amplifier, one equalizer amplifier, and one high-level amplifier each on the right and left channels of the C-200L, constitute the amplification system. These six unit amplifiers are completely independent of one another and each incorporate an exclusive constant-voltage power supply. The mutual interference between the unit amplifiers has been thus eliminated and the stability of each unit amplifier has been significantly improved.

All stages of the signal system are directly coupled by "DC servo system" and thereby constitute straight DC amplification from MC input to output.

In addition to an unbalanced type output

circuit, "600-ohm balanced type output" is provided and the output from the C-200L can be directly coupled with the balanced input to a P-600 power amplifier, P-300L power amplifier, or other audio equipment with balanced type inputs for commercial purposes.

An additional line input terminal is provided to keep abreast with the era of multiple program sources. "Front Subpanel System" is employed and therefore, the input and output terminals are also provided on the front panel.

The six independent unit amplifiers are affixed to a glass epoxy "motherboard" to assure stable performance. This motherboard is in turn secured to a solid housing of a construction highly resistant to vibration.

The C-200L can be used as an associated preamplifier not only for the P-300L but all other power amplifiers.

1 CLASS-A CASCODE PUSH-PULL CIRCUITRY REALIZES IDEAL AMPLIFIER CIRCUIT

Fig. 1 shows the circuit configuration of the C-200L equalizer and high-level amplifiers. Input field-effect transistor (FET) Q_{1a} serves as a buffer stage for direct coupling of the amplification stages. Combined with transistor Q_2 , the Q_{1a} constitutes a cascode connection. At the following stage is the Class-A Cascode Push-Pull Differential amplifier comprising transistors Q_3 through Q_6 and Q_9 through Q_{12} . Moreover, transistors Q_{14} through Q_{17} also make up another Class-A Cascode Push-Pull amplifier that drives the Class-A Darlington Push-Pull amplifier consisting of Q_{18} through Q_{21} at the output stage.

The basic circuit of the cascode connection amplifier is shown in Fig. 2. As seen, common-emitter transistor Q_1 and common-base transistor Q_2 are serially connected as though they were one element. Because of the low input impedance of Q_2 , the load impedance of Q_1 is accordingly low, assuring stable operations. The cascode connection amplifier features a small feedback between the input and output stages and thereby provides excellent characteristics, especially at a high frequency. Namely, the gain is high, the linearity is maintained up to the operation limits of the elements, the distortion is significantly decreased, and the signal-to-noise ratio is improved. In short, ideal performance can be expected of a cascode connection amplifier, but since the cascode connection amplifier in the C-200L consists of Class-A Push-Pull circuitry, the characteristics are even further improved.

With the Class-A Darlington pair push-pull circuitry at the output stage, the input impedance can be increased. Consequently, the operations of Q_{14} through Q_{17} at the preceding stage are hardly influenced by the load, realizing an amplifier with a low distortion and a wide dynamic range.

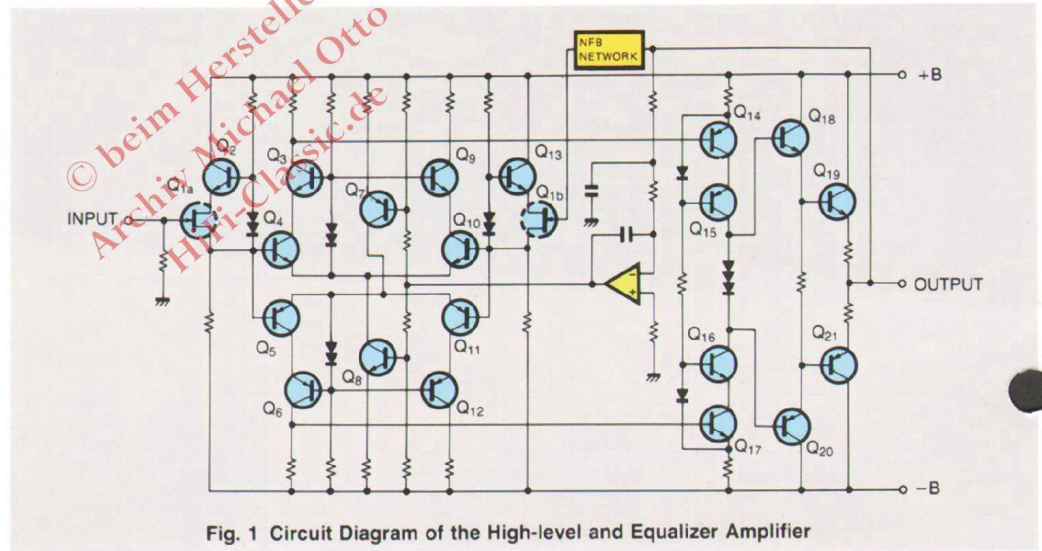

Fig. 1 Circuit Diagram of the High-level and Equalizer Amplifier

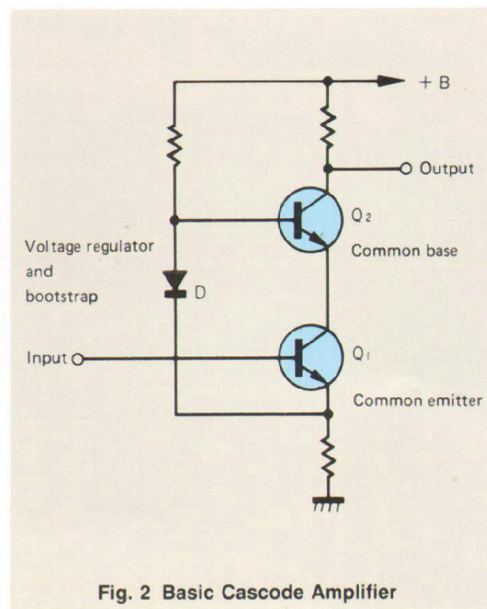
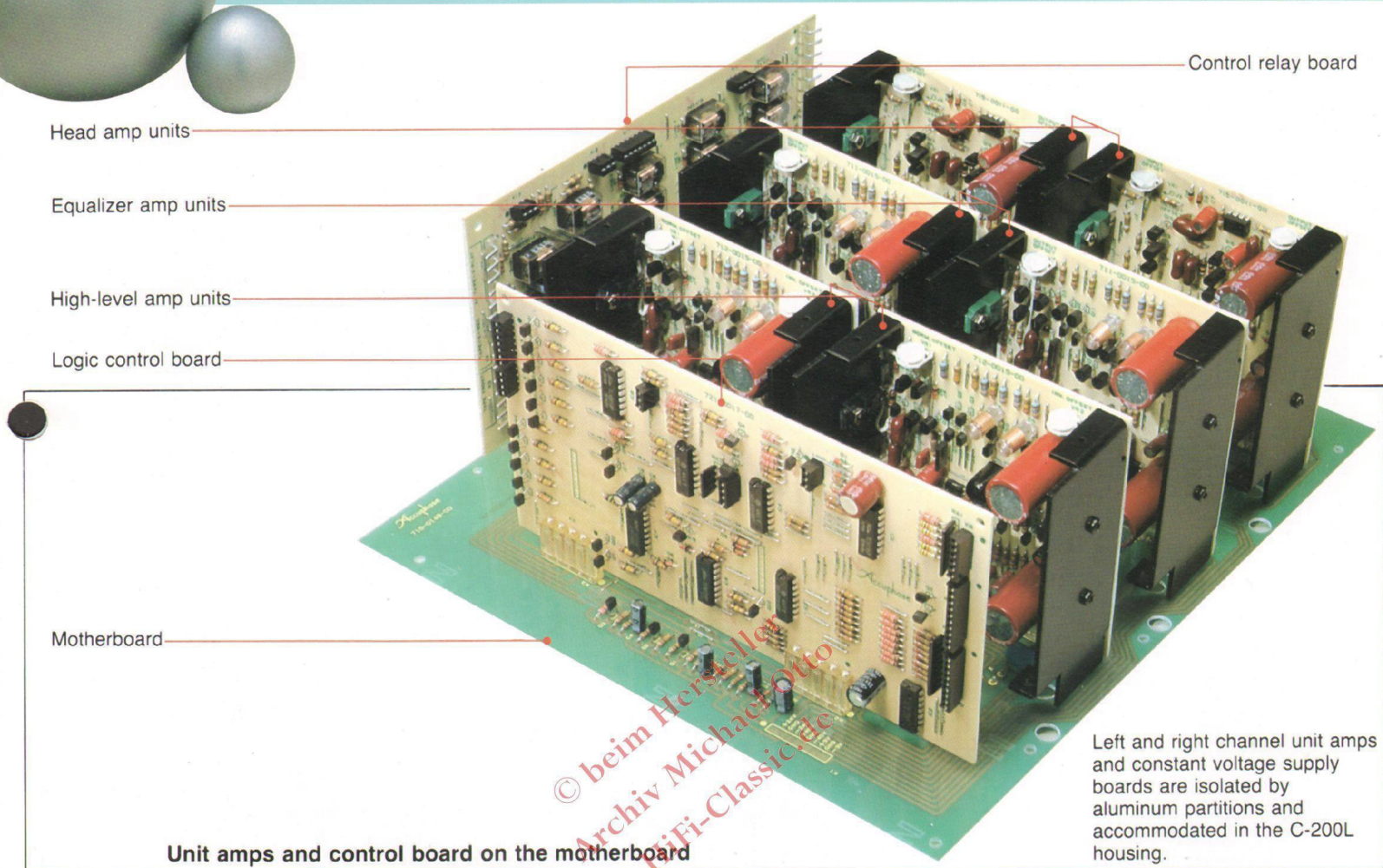

Fig. 2 Basic Cascode Amplifier

2 HEAD AMPLIFIER FOR MC (MOVING COIL) CARTRIDGE WITH WIDE DYNAMIC RANGE REPRODUCES IN EXQUISITE DETAIL

The head amplifier for use with an MC cartridge is of sophisticated construction in that an exclusive amplifier is placed in front of the equalizer amplifier. The circuit configuration of the head amplifier is illustrated in Fig. 3. As can be seen, it consists of three stages: a cascode push-pull differential, a cascode push-pull circuit, and a Darlington push-pull circuit. The signal level of a head amplifier is usually very low, which is likely to affect the signal-to-noise ratio. In the C-200L, however, only elements designed with particular consideration given to decreasing its impedance, thus realizing the remarkable signal-to-noise ratio. The signals from the MC cartridge are directly input to

All-stage push-pull circuitry. DC servo direct coupled power supply. Head amp with selectable input impedance.



Unit amps and control board on the motherboard

Left and right channel unit amps and constant voltage supply boards are isolated by aluminum partitions and accommodated in the C-200L housing.

transistors Q_2 and Q_3 in Fig. 3 to achieve superb reproduction of sounds. The subtle sounds of program sources and the characteristics of the cartridge can be transmitted with incredible fidelity.

3 STRAIGHT DC AMPLIFICATION FROM MC INPUT TO OUTPUT THANKS TO DC SERVO SYSTEM COVERING ALL UNIT AMPLIFIERS

The IC shown in Figs. 1 and 3 constitutes the DC Servo Control circuit. This IC eliminates DC drift by feeding back to the input any DC current appearing at its output. The C-200L has a maximum total gain of 92 dB. Yet, all of its signal paths, from the MC cartridge input to the final output, are directly coupled one stage to the next in a straight DC operation. This is made possible by good circuit design and the use of an effective DC Servo system which eliminates DC drift completely. This feature also accounts for the high quality sound of the C-200L that carries no trace of coloration.

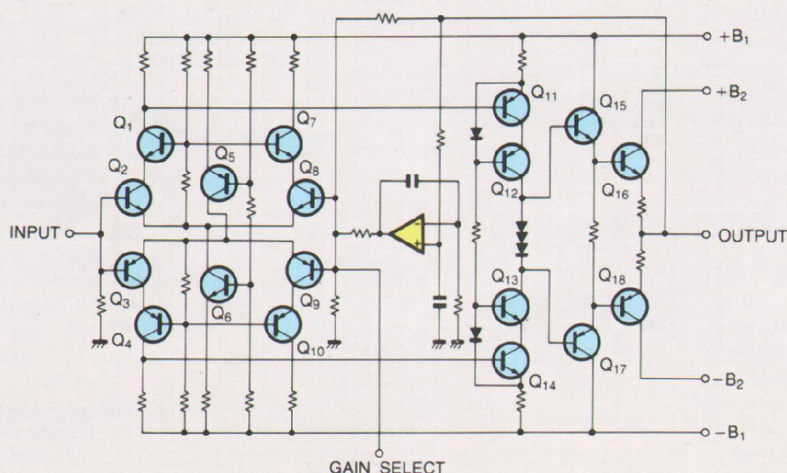

Fig. 3 Circuit Diagram of the Head Amplifier

4 EXCLUSIVE CONSTANT-VOLTAGE POWER SUPPLY REINFORCES UNIT AMPLIFIERS' PERFORMANCE

The total gain of the C-200L is 92 dB maximum which is amazingly high (approx. 40,000 times). If all unit amplifiers are operated by the supply voltage from a single power supply, the chances are a fluctuation may be caused by a large amplitude in the output stage. This fluctuation will, in turn, affect the input stage and consequently, unstable phenomena such as oscillation and distortion will generate. In principle, therefore, each unit amplifier must be driven by an independent power supply.

Each unit amplifier in the C-200L is driven by means of the independent secondary coil of the power transformer and an independent rectifier circuit. What is more, they are each provided with an exclusive constant-voltage power supply to stabilize their individual characteristics and to eliminate the interference among unit amplifiers.

5 STRAIGHT AND SHORTEST SIGNAL PATH BY MEANS OF LOGIC RELAY CONTROL

If the signal path is drawn around for the purpose of achieving such functions as input selection and tape monitoring, degradation of the high frequency characteristics or unstable

throughout. All unit amps provided with exclusive regulated ance and gain for optimum matching with MC cartridges.

phenomena may result. To realize a straight and shortest signal path, relays are placed at locations on the signal path of the C-200L where a switch is required. These relays are electronically controlled by a logic circuit to switch over inputs. The employed relays are of airtight type that is exclusively used for audio equipment and designed to provide high reliability and durability.

6 IMPEDANCE AND GAIN SELECTORS ENSURE BEST INPUT MATCHING

The C-200L is provided with excellent input matching to various MC cartridges which come in such wide variations of impedances and output levels. For example, output impedances of MC cartridges vary all the way from 2 ohms to almost 50 ohms, a difference of 20 or 30 times. Likewise, their output voltage levels vary from 0.01 mV to 0.5 mV, a difference of 50 times (34 dB). Although matching MC cartridges to the head amplifier is not as critical as for transformer coupling, low output impedance cartridges should be coupled to low input impedance to obtain best performance.

To accommodate this wide variety of MC cartridges and preserve fine control of sound quality, the C-200L provides a choice of input impedance of 10 ohms, 30 ohms or 100 ohms.

This permits coupling MC cartridges of about 3-ohm impedance to a load of 10 ohms or 30 ohms, and cartridges of over 10-ohm impedance to either a load of 30 ohms or 100 ohms for closer matching.

Also to accommodate MC cartridges with very low output levels, a Gain Selector switch in the C-200L raises the gain to 32 dB instead of the normally operated head amp gain of 26 dB.

Signal input levels to the head amplifier are based on RIAA recording characteristics that drop in the low frequencies and rise in the high frequency range. A signal at 20,000 Hz would be about 20 dB, 10 times that of a signal at 1,000 Hz. Therefore, the maximum input level of head amplifiers must extend at least to a level of 50 mV. Extension is provided up to 150 mV in the C-200L and this wide dynamic range gives it ample margin to handle any input pulse signal voltages.

7 600-OHM BALANCED TYPE OUTPUT CONNECTOR FOR LOW NOISE LONG CABLE CONNECTIONS

The use of a 600-ohm balanced type cable network has long been a standard practice by broadcasting stations, and also for commercial audio applications when long signal carrying cables are required, since it effectively prevents noise pickup. The C-200L is equipped with an output connector for connecting such balanced cables. The principle is shown in Fig. 4 in which equal positive and negative signal voltages in relation to ground potential are transmitted by the balanced cable network. Even if unwanted disturbances are picked up by the cable, the positive and negative noises appear in the same phase and are effectively canceled out by a phase inverted circuit in the

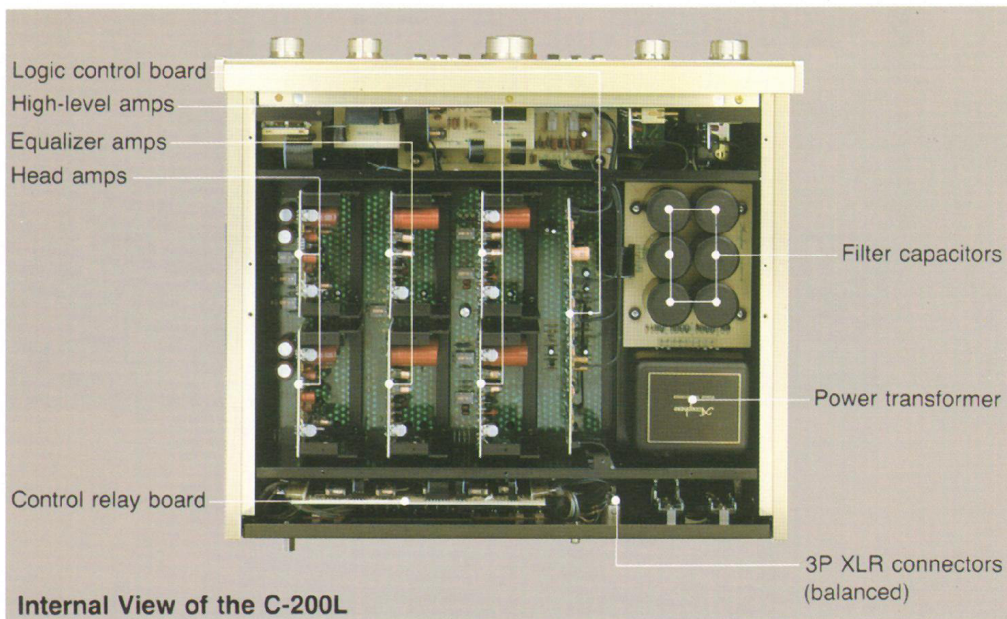

input stage of the power amplifier. In short, such a balanced line prevents noise pickup and ensures minimum deterioration of signal sound quality from long cable connections. However, the components on both sides must be equipped with 600-ohm balanced type cable connectors.

8 WIDE TONE CONTROL CHOICES

Separate tone control circuits are provided for the left and right channels. Tone is varied with a 10-step rotary switch in 1.5 dB steps. The circuitry also offers switch selection of turnover frequencies, which further widens tonal variation choices in the lower and high frequency ranges with 200 Hz and 500 Hz bass turnover frequency points, and 2 kHz and 7 kHz treble turnover frequencies. Also available is an ON/OFF Switch with which the tone control circuitry can be cut off or activated as desired.

during low level reproduction. A choice of the two compensating curves are offered, whose selection is governed by the sound reproduction level and listening room acoustics. COMP 1 provides a +3 dB boost at 100 Hz. COMP 2 provides a +8 dB boost at 100 Hz and a +6 dB boost at 20 kHz (with volume set at -30 dB). The degree of the compensation is automatically adjusted according to the position of the VOLUME control.

10 COMPLETE TAPE RECORDER FUNCTIONS

A total of three tape recorders can be connected to this preamplifier (one to the front Sub Panel). Any two of these machines can be used for tape copying from one machine to another. This can be done while simultaneously listening to a completely different program source since the Copying Switch is independent.

9 TWO-STEP LOUDNESS COMPENSATOR

A two-step Loudness Compensator Switch provides a choice of two sound energy balancing curves to make up for the deficiency of the human ear to detect certain audio frequencies

11 AMPLE NUMBER OF INPUT/OUTPUT CONNECTORS

Plenty of INPUT/OUTPUT connectors are available for convenience in handling a large number of program sources, and conducting various tests of sound equipment. A total of eleven inputs include three pairs of DISC, one pair for TUNER, four pairs of LINE and three pairs of TAPE PLAY connectors. This preamplifier also has a total of seven outputs that include four pairs of OUTPUT connectors, three pairs of TAPE REC connectors and one headphone jack. One pair each of DISC, LINE, TAPE PLAY, TAPE REC, and OUTPUT connectors and a Headphone jack are located on the frontside Sub Panel for convenience in making tests, etc., and also to eliminate complexity. The DISC input in the Sub Panel is especially useful for testing turntables and phono cartridges.

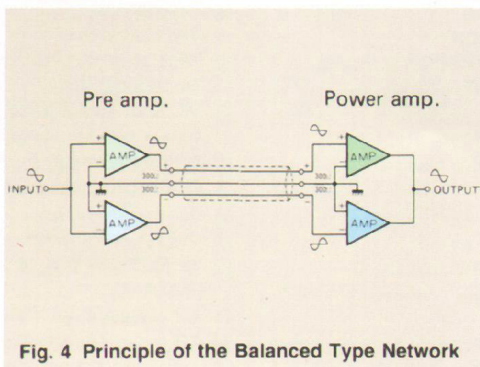
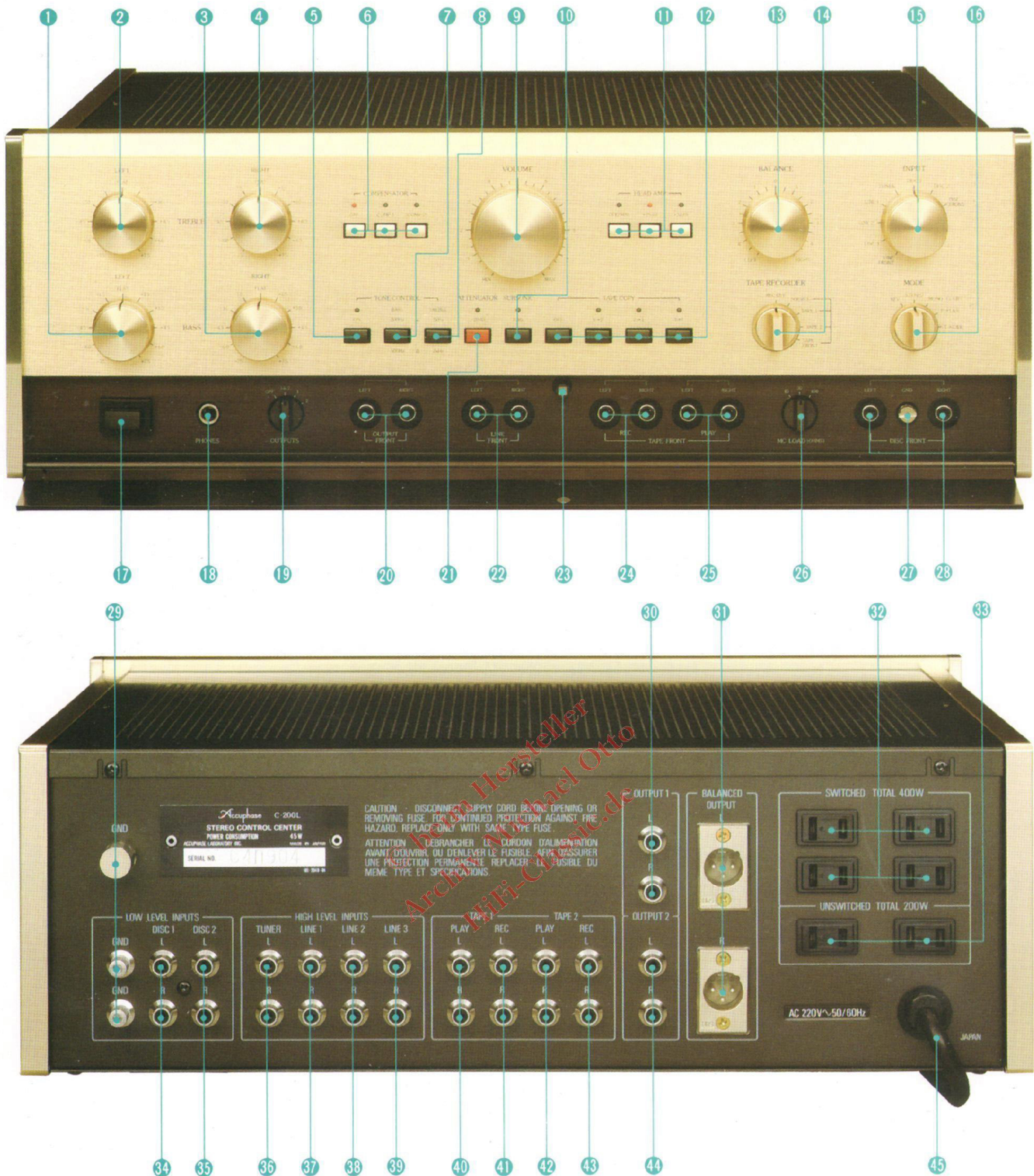

Fig. 4 Principle of the Balanced Type Network



- 1 L-channel low frequency adjustment control
10-step control (1.5 dB step)
- 2 L-channel high frequency adjustment control
10-step control (1.5 dB step)
- 3 R-channel low frequency adjustment control
10-step control (1.5 dB step)
- 4 R-channel high frequency adjustment control
10-step control (1.5 dB step)
- 5 TONE CONTROL ON/OFF switch
- 6 Loudness COMPENSATOR switches
OFF COMP-1 COMP-2
- 7 Low frequency control turnover selector switch
200 Hz/500 Hz
- 8 High frequency control turnover selector switch
2 kHz/7 kHz

- 9 VOLUME level control
- 10 SUBSONIC filter
10 Hz -18 dB/oct
- 11 HEAD AMPLIFIER selector switches for MC cartridge
OFF/MM +26dB +32dB
- 12 TAPE COPYING controls
OFF 1→2 2→1 1→F
- 13 BALANCE control
- 14 Recording monitor/recording output ON/OFF switch
REC OFF SOURCE TAPE-1
TAPE-2 TAPE FRONT
- 15 INPUT selector switch
LINE FRONT LINE-3 LINE-2
LINE-1 TUNER DISC-1
DISC-2 DISC FRONT
- 16 MODE selector switch
REV STEREO MONO (L + R)
R→L&R L→L&R
- 17 POWER switch
- 18 Output jack for HEADPHONES

- 19 OUTPUT selector switch
OFF 1&2 1 2
- 20 Output jacks on the front panel
- 21 Pushbutton ATTENUATOR
-20 dB
- 22 Line input jacks on the front panel
- 23 Magnetic catch for subpanel
- 24 Tape recorder RECOding jacks on the front panel
- 25 Tape recorder PLAYback jacks on the front panel
- 26 MC load selector switch
10Ω 30Ω 100Ω
- 27 Ground terminal on the front panel
- 28 Front panel jacks for turntable
- 29 Ground terminals
- 30 Output jacks (UNBALANCED/1Ω)
- 31 3P XLR type output jacks (BALANCED/600Ω)
- 32 AC outlets (SWITCHED)
- 33 AC outlets (UNSWITCHED)
- 34 Turntable 1 input jacks

- 35 Turntable 2 input jacks
- 36 Tuner input jacks
- 37 Line input jacks
- 38 Line input jacks
- 39 Line input jacks
- 40 Tape recorder 1 PLAY back jacks
- 41 Tape recorder 1 recording output jacks
- 42 Tape recorder 2 PLAY back jacks
- 43 Tape recorder 2 recording output jacks
- 44 Output jacks (UNBALANCED/1Ω)
- 45 AC power cord

Accuphase C-200L

STEREO CONTROL CENTER

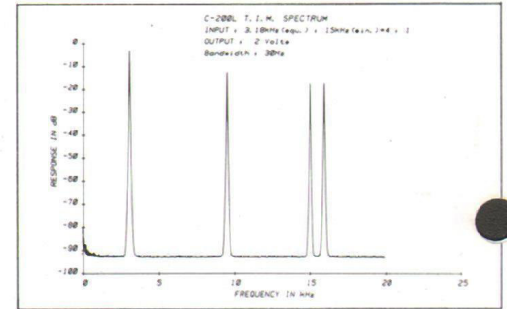
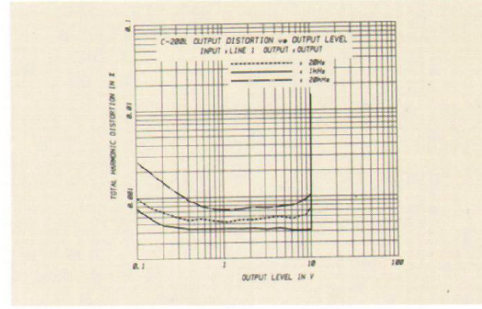
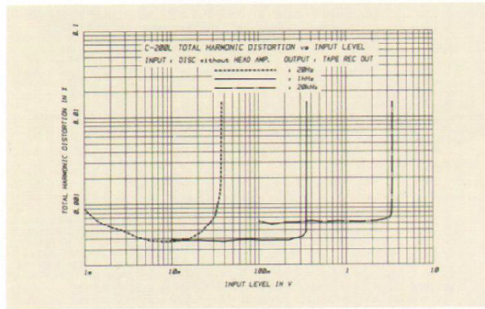
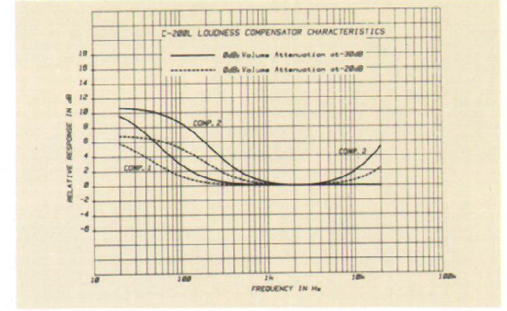
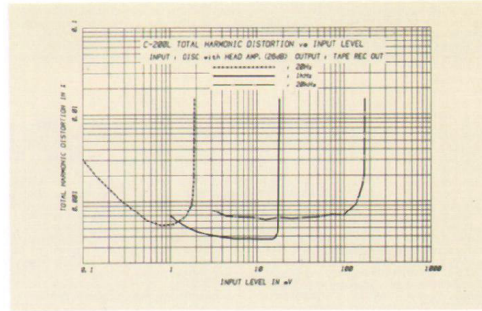
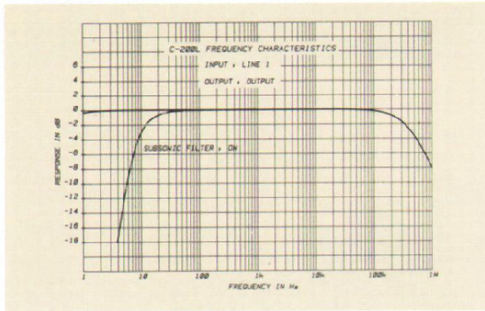

The above data shows the spectrum characteristics of transient intermodulation distortion for the C-200L when two mixed input signals, a 3.18 kHz square wave and a 15 kHz sine wave, are used. Since harmonics of square waves appear almost infinitely at odd-number multiples, for example in this case at 9.54 kHz (3rd harmonic) and 15.9 kHz (5th harmonic), they can create, together with the 15 kHz input sine wave, intermodulated spectrums at frequencies where input signals are absent. For example, if the third harmonic of the 3.18 kHz square wave (9.54 kHz) and the 15 kHz input signal intermodulate, a spectrum can appear at the difference of their frequencies, or 5.46 kHz (15-9.54=5.46 kHz). However, the above data shows no spectrum above -93 dB at that frequency. This confirms that TIM distortion is less than 0.0022%.

C-200L GUARANTY SPECIFICATIONS

- PERFORMANCE GUARANTY:**
All Accuphase product specifications are guaranteed as stated.
- FREQUENCY RESPONSE:**
TUNER/LINE/
TAPE PLAY INPUT: 1 Hz to 500,000 Hz: +0, -3.0 dB
20 Hz to 20,000 Hz: +0, -0.2 dB
DISC INPUT: 20 Hz to 20,000 Hz: ±0.2 dB
- TOTAL HARMONIC DISTORTION (EIA):**
Will not exceed 0.005% at rated output level, 20 Hz to 20,000 Hz
- INPUT SENSITIVITY AND IMPEDANCE:**

Input Terminal	Sensitivity		Impedance (ohms)
	Rated Output	EIA Standard (0.5V Output)	
DISC (Head Amp OFF/MM)	2.0 mV	0.5 mV	47 k
DISC (Head Amp: +26 dB)	0.1 mV	0.025 mV	10, 30, 100
DISC (Head Amp: +32 dB)	0.05 mV	0.0125 mV	10, 30, 100
TUNER/LINE TAPE PLAY	126 mV	31.5 mV	20 k

- OUTPUT LEVEL AND IMPEDANCE:**
OUTPUT (UNBALANCED): 2.0V, 1.0 ohm (Connector: Phono Jack)
OUTPUT (BALANCED): 2.0V, 600 ohms (Connector: XLR type)
TAPE REC: 126mV, 200 ohms (Input: DISC)

- HEADPHONE JACK:**
For listening with low impedance (4 to 100 ohms) dynamic stereo headphones.

- A-WEIGHTED SIGNAL-TO-NOISE RATIO:**

Input Terminal	Rated Input	EIA
DISC (Head Amp OFF/MM)	85 dB	82 dB
DISC (Head Amp: +26 dB)	72 dB	76 dB
DISC (Head Amp: +32 dB)	66 dB	76 dB
TUNER/LINE TAPE PLAY	110 dB	88 dB

- MAXIMUM OUTPUT LEVEL (at 0.005% distortion, 20 Hz to 20,000 Hz):**
OUTPUT (UNBALANCED): 8.0V (Connector: Phono Jack)
OUTPUT (BALANCED): 8.0V (Connector: XLR type)
TAPE REC: 19.0V (Input: DISC)

- MAXIMUM INPUT FOR DISC INPUT (at 0.005% distortion, 1 kHz):**
HEAD AMP OFF/MM: 300 mV
HEAD AMP +26 dB: 15 mV
HEAD AMP +32 dB: 7.5 mV

- MINIMUM LOAD IMPEDANCE:**
OUTPUT (UNBALANCED): 1k ohms minimum
TAPE REC: 10k ohms minimum

- VOLTAGE AMPLIFICATION IN DECIBELS:**
TUNER/LINE/TAPE PLAY Input to OUTPUT: 24 dB
TUNER/LINE/TAPE PLAY Input to TAPE REC Output: 0 dB
DISC (Head Amp OFF/MM) Input to OUTPUT: 60 dB

DISC (Head Amp OFF/MM) Input to TAPE REC Output: 36 dB
HEAD AMP Gain: Selectable for +26 dB and +32 dB

- TO NE CONTROLS:**
10-step Rotary Switch for both channels with turnover frequency switches and ON/OFF switch. Tone is varied in 1.5 dB steps.
BASS: Turnover Frequency: 500 Hz ± 7.5 dB at 100 Hz
200 Hz ± 7.5 dB at 40 Hz
TREBLE: Turnover Frequency: 2,000 Hz ± 7.5 dB at 10 kHz
7,000 Hz ± 7.5 dB at 35 kHz
- LOUDNESS COMPENSATOR (volume attenuation at -30 dB):**
COMP 1: +3 dB at 100 Hz
COMP 2: +8 dB at 100 Hz, +6 dB at 20 kHz
- SUBSONIC FILTER:** 10 Hz cutoff, -18 dB/oct.
- ATTENUATOR:** -20 dB
- SEMICONDUCTOR COMPLEMENT:**
164 Trs, 16 FETs, 21 ICs and 123 Di's
- POWER REQUIREMENT:**
Voltage selection by rewiring for 100V, 117V, 220V and 240V, 50/60 Hz operation
Power Consumption: 45 watts
- DIMENSIONS:**
width 445mm (17-1/2 inches), max. height 160mm (6-5/16 inches), depth 373mm (14-11/16 inches)
- WEIGHT:**
13.6 kg (30.0 lb) net, 18.1 kg (40.0 lb) in shipping carton

Accuphase
ACCUPHASE LABORATORY INC.